

## Gas Detector with Signal Converter

### SD-3RI Series SPECIFICATION

Model	SD-3RI		SD-3DRI	
Detection principle	Non-dispersive infrared type			
Detection gas*1	Combustible gas and toxic gas			
Display	7-segment LED (5 digits), 3-color lamp (red, green, yellow)			
Detection range*1	Depends on sensor specifications			
Alarm set points*1	Depends on sensor specifications			
Sampling method	Diffusion type	Suction type (pour into by external unit)		
Setting flow rate	—		0.4 – 1.5 L/min	
Power supply indication	Power lamp lit (green)			
Gas alarm	Alarm type	Two-step alarm (H-HH)		
	Indication	Alarm lamp lit (red)		
	Reset type*1	Auto reset or self-latching		
Fault alarm	Self-diagnosis	System abnormality (E-9), sensor abnormality (E-1)		
	Indication	Fault lamp lit (yellow), error code display		
	Reset type	System abnormality: Self-latching Sensor abnormality: Auto reset (self-latching if sensor is disconnected)		
Warnings	Self-diagnosis	Sensor life assessment, clock abnormality diagnosis, communication diagnosis, sensor warning		
	Display	Blinking display alternating between gas concentration and error code		
	Operation	Same as normal operation		
Functions	Alarm delay, suppression, HART communication (HART7)			
External output*1	Gas concentration signal (4-20 mA DC with HART output), contact output (optional)			
Gas concentration signal	Transmission Method	3-wire analog transmission (common power supply <power supply, signal, common>) or 2-wire analog transmission (current source)		
	Transmission Specifications	4-20 mA DC (non-insulated linear output) Maximum load resistance 600 Ω (with derating depending on power supply voltage) Resolution: max. 2000 divisions (depending on specifications)		
	Transmission cable*2	Shielded cable 1.25 sq (1.308 mm <sup>2</sup> /AWG16) or 2.0 sq (2.08 mm <sup>2</sup> /AWG14) (same as power supply cable)		
	Transmission Distance*7	For 1.25 sq (1.308 mm <sup>2</sup> /AWG16): Not exceeding 1.25 km For 2.0 sq (2.08 mm <sup>2</sup> /AWG14): Not exceeding 2 km (with derating depending on supply voltage)		
Alarm contact (Optional)*1	SPDT (× 3): 2 alarms, 1 fault output, non-exciting at normal (exciting at alarm) or exciting at normal (non-exciting at alarm), 250 V AC, 2 A; 30 V DC, 1 A (resistance load), Minimum load 5V DC, 0.1A			
Power supply	Input voltage range*3	24 V DC (18 V – 30 V DC)		
	Power supply cable*2*7	Shielded cable 1.25 sq (1.308 mm <sup>2</sup> /AWG16) or 2.0 sq (2.08 mm <sup>2</sup> /AWG14) (same as transmission cable)		
	Power consumption	Max. 3.8 W		
Housing	Material	Stainless steel: SCS14 (equivalent to SUS316)		
	Cable connectors*1	ATEX/IECEx: M25×1.5, conversion adapter (optional): NPT3/4, NPT1/2, M20×1.5 Japan Ex: Flame proof packing method <M20×1.5> (Compatible cables φ6.0~12.0mm), <M25×1.5> (Compatible cables φ12.0~16.0mm)		
	Tube connecting port	—	NPT1/4 (with SUS elbow union for 0.0φ8-1t)	
	Degrees of protection	Equivalent to IP66/67		
	Installation type*1	Wall mounting (standard)/2B pole mounting (optional)		
	External dimensions*5	Approx. 171(W) × 277(H) × 127(D) mm (excluding projections)	Approx. 171(W) × 289(H) × 127(D) mm (excluding projections)	
	Weight*5	Approx. 6.7 kg	Approx. 7.0 kg	
Operating temperature range*4	ATEX/IECEx: -40 °C – +70 °C (no sudden changes) Japan Ex: -20 °C – +70 °C (no sudden changes)			
Operating humidity range*4	0 %RH – 95 %RH (no condensation)			
Operation method	Dedicated magnet control key			
Type of protection	Flameproof construction			
Explosion-proof approvals	ATEX	II 2G Ex db IIC T6/T5 Gb, -50°C ≤ Ta ≤ +60°C/+70°C (when lightning arrester is not installed), -40°C ≤ Ta ≤ +60°C/+70°C (when lightning arrester is installed)		
	IECEx	Ex db IIC T6/T5 Gb, -50°C ≤ Ta ≤ +60°C/+70°C (when lightning arrester is not installed), -40°C ≤ Ta ≤ +60°C/+70°C (when lightning arrester is installed)		
	Japan Ex	Ex db IIC T5 Gb, -20°C ≤ Ta ≤ +70°C		
Functional safety (IEC61508:2010)*6	SIL2 capable (HFT=0), SIL3 capable (HFT=1) with redundancy			
Certification	CE Marking			

\*1 Please specify your request when ordering.

\*2 To ensure explosion protection, use a cable designed for use in temperatures at least 5 °C above the maximum anticipated ambient temperature.

\*3 Use a power supply capable of minimum temporary output of 2.5 A to ensure that fuses blow normally in the event of a product abnormality.

\*4 In accordance with sensor specifications if restrictions apply due to sensor specifications.

\*5 External dimensions and weight exclude cable gland.

\*6 External units used in combination with SD-3DRI should be selected from SIL certified products.

\*7 Depends on the type of cable.

Dimensional drawings (Excluding cable gland)

<Diffusion type>

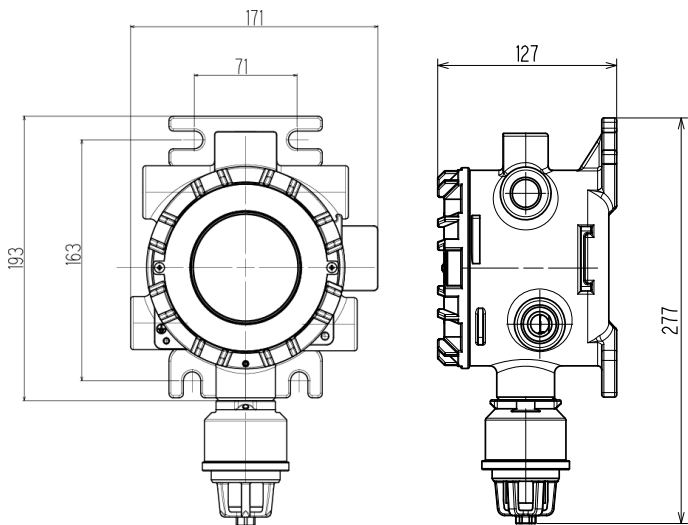

<Suction type>

\* Pour into by external unit

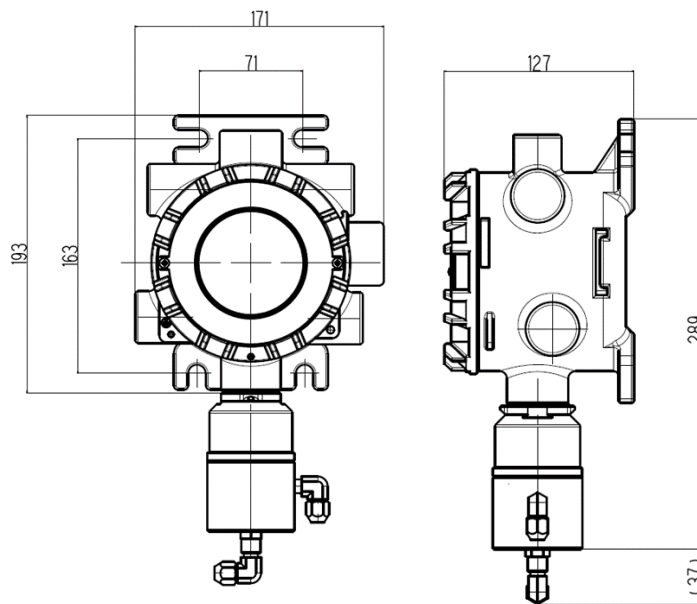

Terminal Block Diagram

<Using 3-core cable>

Terminal No.	Power/signal cable connection	
1	Power supply (+)	24 V DC
2	Common (Power supply (-), signal (-))	
3	Signal (+)	4-20 mA with HART
4	Not used	

<Using 4-core cable>

Terminal No.	Power/signal cable connection	
1	Power supply (+)	24 V DC
2	Power supply (-)	
3	Signal (+)	4-20 mA with HART
4	Signal (-)	

<Contact output (Optional)>

Relay1 (ALARM1)

Terminal No.	Cable connection
1	N. O.
2	Common
3	N. C.

Relay2 (ALARM2)

Terminal No.	Cable connection
1	N. O.
2	Common
3	N. C.

Relay3 (FAULT)

Terminal No.	Cable connection
1	N. O.
2	Common
3	N. C.

N. O. : Normal Open  
N. C. : Normal Close