

Providing everything gas detectors can do to improve productivity.

Fixed Gas Detector Head for Semiconductor Plants

MODEL

GD-81D Series

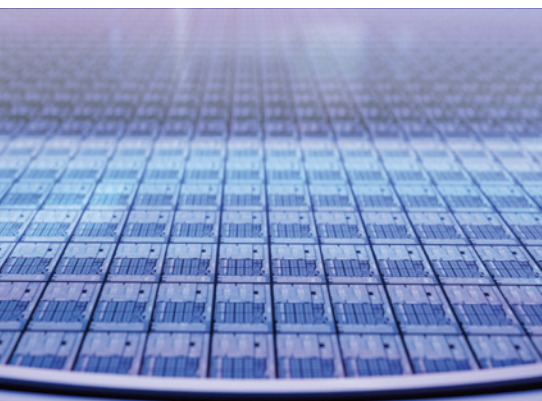

- **Up to 2-component simultaneous detection** — 2-in-1 construction saves space and costs
- **Remote monitoring** — Easy access to device information via web browser
- **Quiet, long-lasting pump** — New construction to ensure reliable operation



Carrying on **the legacy of reliability** to **the next stage**

Compatible sensor units —

Communication method —

U sensor unit

Ethernet

Supports web browser function

F sensor unit **NEW**

4–20 mA

M sensor unit **NEW**

Simultaneous two-component toxic gas detection

Choice of three different sensor units

U sensor unit



Conventional sensor unit compatible with a lineup of more than 300 sensor types and boasting high reliability.

F sensor unit **NEW**



F sensor
1 sensor

The unit accommodates one new F sensor which features significantly enhanced self-diagnostic functions. Also supports CO₂ (ppm to vol%) detection.

M sensor unit **NEW**



F sensor
2 sensors

Sensor unit that can accommodate two F sensors for toxic gases.

Detects two different toxic gases simultaneously

Designed for easier replacement of previous models

Same size allowing seamless expansion

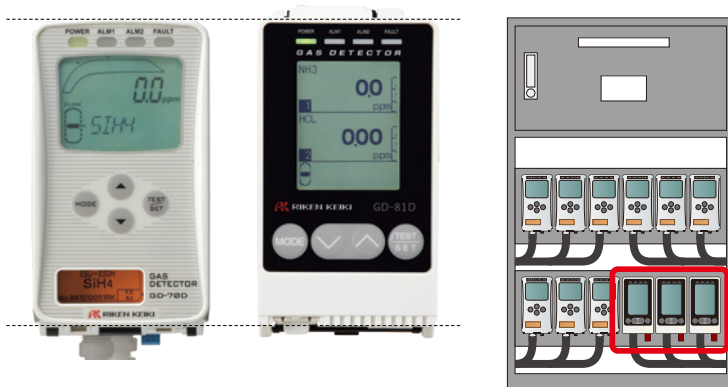

The main unit size is identical to the previous GD-70D Series, allowing easy replacement and expansion, with zero worries about installation space.

Can be used with the same U sensor units



Even when used alongside previous models, sensor units can be used interchangeably, simplifying procurement and management.

Lineup of main gases

Detection principle: Electrochemical type (ESU/ESF)

U sensor unit/F sensor unit

No.	Gas name	Display name	Detection range	Alarm setpoints	ACGIH acceptable concentration (2025)
1	Ammonia	NH ₃	0 – 75 ppm	25 ppm / 50 ppm	25 ppm
2	Monomethylamine	MMTA	0 – 15 ppm	5 ppm / 10 ppm	5 ppm
3	Dimethylamine	DMA	0 (0.9) – 15 ppm	5 ppm / 10 ppm	5 ppm
4	Trimethylamine	TMA	0 – 15 ppm	5 ppm / 10 ppm	5 ppm
5	Diethylamine	DEA	0 (0.2) – 15 ppm	5 ppm / 10 ppm	5 ppm
6	Methylethylamine	EMA	0 – 15 ppm	5 ppm / 10 ppm	—
7	Fluorine	F ₂	0 – 3 ppm	1 ppm / 2 ppm	0.1 ppm
8	Hydrogen fluoride	HF	0 (0.4) – 1.5 ppm	0.5 ppm / 1 ppm	0.5 ppm
9	Chlorine	Cl ₂	0 – 0.3 ppm	0.1 ppm / 0.2 ppm	0.1 ppm
10	Hydrogen chloride	HCl	0 – 6 ppm	2 ppm / 4 ppm	2 ppm
11	Bromine	Br ₂	0 – 1 ppm	0.3 ppm / 0.6 ppm	0.1 ppm
12	Hydrogen bromide	HBr	0 – 6 ppm	2 ppm / 4 ppm	2 ppm
13	Chlorine trifluoride	ClF ₃	0 – 0.3 ppm	0.1 ppm / 0.2 ppm	0.1 ppm
14	Ozone	O ₃	0 – 0.6 ppm	0.2 ppm / 0.4 ppm	0.2 ppm (<2h)
15	Silane	SiH ₄	0 – 15 ppm	5 ppm / 10 ppm	5 ppm
16	Disilane	Si ₂ H ₆	0 – 15 ppm	5 ppm / 10 ppm	—
17	Phosphine	PH ₃	0 – 0.15 ppm	0.05 ppm / 0.1 ppm	0.05 ppm
18	Diborane	B ₂ H ₆	0 – 0.3 ppm	0.1 ppm / 0.2 ppm	0.1 ppm
19	Hydrogen cyanide	HCN	0 (0.9) – 15 ppm	4 ppm / 10 ppm	4.7 ppm
20	Germane	GeH ₄	0 – 0.8 ppm	0.2 ppm / 0.4 ppm	0.2 ppm
21	Arsine	AsH ₃	0 – 50 ppb	10 ppb / 20 ppb	0.005 ppm
22	Hydrogen selenide	H ₂ Se	0 – 0.2 ppm	0.05 ppm / 0.1 ppm	0.05 ppm
23	Carbon monoxide	CO	0 – 75 ppm	25 ppm / 50 ppm	25 ppm
24	Nitrogen monoxide	NO	0 – 100 ppm	25 ppm / 50 ppm	25 ppm
25	Nitrogen dioxide	NO ₂	0 – 9 ppm	3 ppm / 6 ppm	0.2 ppm
26	Sulfur dioxide	SO ₂	0 – 6 ppm	2 ppm / 4 ppm	0.25 ppm
27	Nitrogen trifluoride	NF ₃	0 – 30 ppm	10 ppm / 20 ppm	10 ppm
28	Oxygen	O ₂	0 – 25 vol%	18 vol% / 18 vol%	—
29	Hydrogen	H ₂	0 – 2,000 ppm	500 ppm / 1,000 ppm	—

Detection principle: Hot-wire semiconductor type (SHU/SHF)

U sensor unit/F sensor unit

No.	Gas name	Display name	Detection range	Alarm setpoints	ACGIH acceptable concentration (2025)
30	Freon 41	R-41	0 – 2,000 ppm	500 ppm / 1,000 ppm	—
31	Freon 32	R-32	0 – 2,000 ppm	500 ppm / 1,000 ppm	—
32	Isopropyl alcohol	IPA	0 – 2,000 ppm	500 ppm / 1,000 ppm	200 ppm
33	Ethylene	C ₂ H ₄	0 – 2,000 ppm	500 ppm / 1,000 ppm	200 ppm
34	Propylene	C ₃ H ₆	0 – 2,000 ppm	500 ppm / 1,000 ppm	500 ppm
35	Methane	CH ₄	0 – 5,000 ppm	2,000 ppm / 4,000 ppm	—
36	Perfluorobutadiene	C ₄ F ₆	0 – 2,000 ppm	500 ppm / 1,000 ppm	—
37	Isobutane	i-C ₄ H ₁₀	0 – 2,000 ppm	500 ppm / 1,000 ppm	1,000 ppm
38	Acetylene	C ₂ H ₂	0 – 2,000 ppm	500 ppm / 1,000 ppm	—
39	Propane	C ₃ H ₈	0 – 2,000 ppm	500 ppm / 1,000 ppm	—
40	Ethyl alcohol	C ₂ H ₅ OH	0 – 2,000 ppm	500 ppm / 1,000 ppm	1,000 ppm
41	Acetone	C ₃ H ₆ O	0 – 2,000 ppm	500 ppm / 1,000 ppm	250 ppm
42	Deuterium	D ₂	0 – 2,000 ppm	500 ppm / 1,000 ppm	—
43	Hydrogen	H ₂	0 – 2,000 ppm	500 ppm / 1,000 ppm	—

Detection principle: Catalytic combustion type (NCU/NCF)

U sensor unit/F sensor unit

No.	Gas name	Display name	Detection range	Alarm setpoints	ACGIH acceptable concentration (2025)
44	Methane	CH ₄	0 – 100 %LEL	25 %LEL / 50 %LEL	—
45	Ethane	C ₂ H ₆	0 – 100 %LEL	25 %LEL / 50 %LEL	—
46	Propane	C ₃ H ₈	0 – 100 %LEL	25 %LEL / 50 %LEL	—
47	Isobutane	i-C ₄ H ₁₀	0 – 100 %LEL	25 %LEL / 50 %LEL	1,000 ppm
48	Hydrogen	H ₂	0 – 100 %LEL	25 %LEL / 50 %LEL	—
49	Toluene	C ₇ H ₈	0 – 100 %LEL	25 %LEL / 50 %LEL	20 ppm
50	Acetone	C ₃ H ₆ O	0 – 100 %LEL	25 %LEL / 50 %LEL	250 ppm
51	Acetylene	C ₂ H ₂	0 – 100 %LEL	25 %LEL / 50 %LEL	—
52	Ethylene	C ₂ H ₄	0 – 100 %LEL	25 %LEL / 50 %LEL	200 ppm
53	Ethyl alcohol	C ₂ H ₅ OH	0 – 100 %LEL	25 %LEL / 50 %LEL	1,000 ppm
54	Methyl alcohol	CH ₃ OH	0 – 100 %LEL	25 %LEL / 50 %LEL	200 ppm
55	Propylene	C ₃ H ₆	0 – 100 %LEL	25 %LEL / 50 %LEL	500 ppm
56	Vinyl chloride	VCM	0 – 100 %LEL	25 %LEL / 50 %LEL	1 ppm

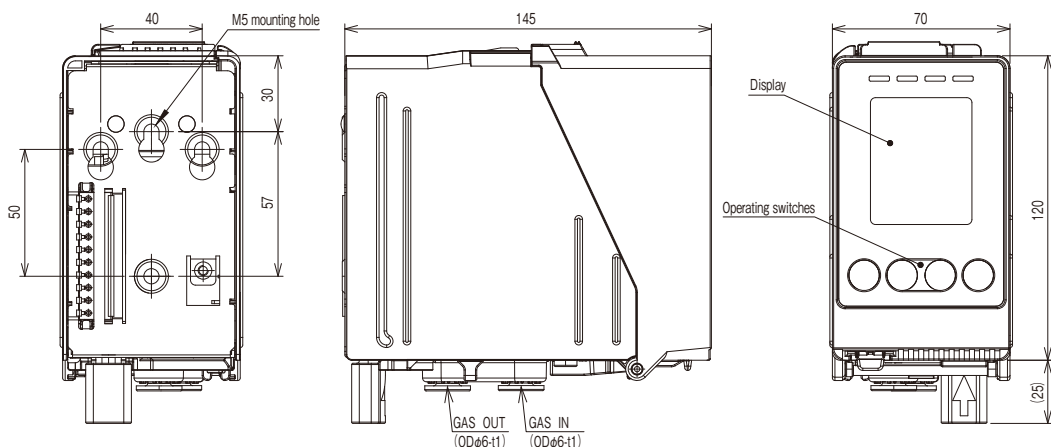

For 4–20 mA
communication
GD-81D

Detection principle: Non-dispersive infrared type (IRU/IRF)

U sensor unit/F sensor unit

No.	Gas name	Display name	Detection range	Alarm setpoints	ACGIH acceptable concentration (2025)
57	Methane	CH ₄	0 – 100 %LEL	25 %LEL / 50 %LEL	—
58	Ethylene	C ₂ H ₄	0 – 100 %LEL	25 %LEL / 50 %LEL	200 ppm
59	Toluene	C ₇ H ₈	0 – 100 %LEL	25 %LEL / 50 %LEL	20 ppm
60	Propylene	C ₃ H ₆	0 – 100 %LEL	25 %LEL / 50 %LEL	500 ppm
61	Acetone	C ₃ H ₆ O	0 – 100 %LEL	25 %LEL / 50 %LEL	250 ppm
62	Benzene	C ₆ H ₆	0 – 100 %LEL	25 %LEL / 50 %LEL	0.02 ppm
63	Freon 32	R-32	0 – 20,000 ppm	5,000 ppm / 10,000 ppm	—
64	Freon 41	R-41	0 – 20,000 ppm	5,000 ppm / 10,000 ppm	—
65	Propane	C ₃ H ₈	0 – 100 %LEL	25 %LEL / 50 %LEL	—
66	Isobutane	i-C ₄ H ₁₀	0 – 100 %LEL	25 %LEL / 50 %LEL	1,000 ppm
67	Ethane	C ₂ H ₆	0 – 100 %LEL	25 %LEL / 50 %LEL	—
68	Normal butane	n-C ₄ H ₁₀	0 – 100 %LEL	25 %LEL / 50 %LEL	—
69	Methyl alcohol	CH ₃ OH	0 – 100 %LEL	25 %LEL / 50 %LEL	200 ppm
70	Ethyl alcohol	C ₂ H ₅ OH	0 – 100 %LEL	25 %LEL / 50 %LEL	1,000 ppm
71	Isopropyl alcohol	IPA	0 – 100 %LEL	25 %LEL / 50 %LEL	200 ppm
72	Normal propyl alcohol	C ₃ H ₇ OH	0 – 100 %LEL	25 %LEL / 50 %LEL	100 ppm
73	Tetrahydrofuran	THF	0 – 100 %LEL	25 %LEL / 50 %LEL	50 ppm
74	Methyl ethyl ketone	MEK	0 – 100 %LEL	25 %LEL / 50 %LEL	75 ppm
75	Ethyl acetate	EtAc	0 – 100 %LEL	25 %LEL / 50 %LEL	400 ppm
76	Methyl isobutyl ketone	MIBK	0 – 100 %LEL	25 %LEL / 50 %LEL	20 ppm
77	Dimethyl carbonate	C ₃ H ₆ O ₃	0 – 100 %LEL	25 %LEL / 50 %LEL	—
78	Ethyl methyl carbonate	EMC	0 – 100 %LEL	25 %LEL / 50 %LEL	—
79	Diethyl carbonate	C ₅ H ₁₀ O ₃	0 – 100 %LEL	25 %LEL / 50 %LEL	—
80	Nitrous oxide	N ₂ O	0 – 500 ppm	50 ppm / 100 ppm	50 ppm
81	Carbon dioxide	CO ₂	0 – 2,000 ppm	1,000 ppm / 1,000 ppm	5,000 ppm
82	Carbon dioxide	CO ₂	0 – 100 vol%	25 vol%/50 vol%	5,000 ppm

Detection principle: Pyrolysis-particle type (SSU)

U sensor unit

No.	Gas name	Display name	Detection range	Alarm setpoints	ACGIH acceptable concentration (2025)
83	Tetraethoxysilane	TEOS	0 – 15 ppm	10 ppm / 10 ppm	10 ppm

Detection principle: Electrochemical type (ESF)

M sensor unit

No.	Gas name	Display name	Detection range	Alarm setpoints	ACGIH acceptable concentration (2025)
84	Ammonia	NH ₃	0 – 75 ppm	25 ppm / 50 ppm	25 ppm
85	Dimethylamine	DMA	0 (0.2) – 15 ppm	5 ppm / 10 ppm	5 ppm
86	Fluorine	F ₂	0 – 3 ppm	1 ppm / 2 ppm	0.1 ppm
87	Hydrogen fluoride	HF	0 (0.4) – 1.5 ppm	0.5 ppm / 1 ppm	0.5 ppm
88	Chlorine	Cl ₂	0 – 0.3 ppm	0.1 ppm / 0.2 ppm	0.1 ppm
89	Chlorine	Cl ₂	0 – 1.5 ppm	0.5 ppm / 1 ppm	0.1 ppm
90	Hydrogen chloride	HCl	0 – 6 ppm	2 ppm / 4 ppm	2 ppm
91	Hydrogen bromide	HBr	0 – 6 ppm	2 ppm / 4 ppm	2 ppm
92	Chlorine trifluoride	ClF ₃	0 – 0.3 ppm	0.1 ppm / 0.2 ppm	0.1 ppm
93	Ozone	O ₃	0 – 0.6 ppm	0.2 ppm / 0.4 ppm	0.2 ppm (<2h)
94	Silane	SiH ₄	0 – 15 ppm	5 ppm / 10 ppm	5 ppm
95	Phosphine	PH ₃	0 – 1 ppm	0.3 ppm / 0.6 ppm	0.05 ppm
97	Monomethylsilane	CH ₃ SiH ₃	0 – 20 ppm	5 ppm / 10 ppm	—
98	Nitrogen monoxide	NO	0 – 100 ppm	25 ppm / 50 ppm	25 ppm
99	Nitrogen dioxide	NO ₂	0 – 15 ppm	5 ppm / 10 ppm	0.2 ppm
100	Sulfur dioxide	SO ₂	0 – 6 ppm	2 ppm / 4 ppm	0.25 ppm
101	Hydrogen	H ₂	0 – 2,000 ppm	500 ppm / 1,000 ppm	—

Pyrolyzer unit

Model: PLU-80

Can be used in combination with the GD-81D Series to detect gases like NF₃ and TEOS. Designed to be the same size as the previous PLU-70 unit, eliminating any concerns about installation space.

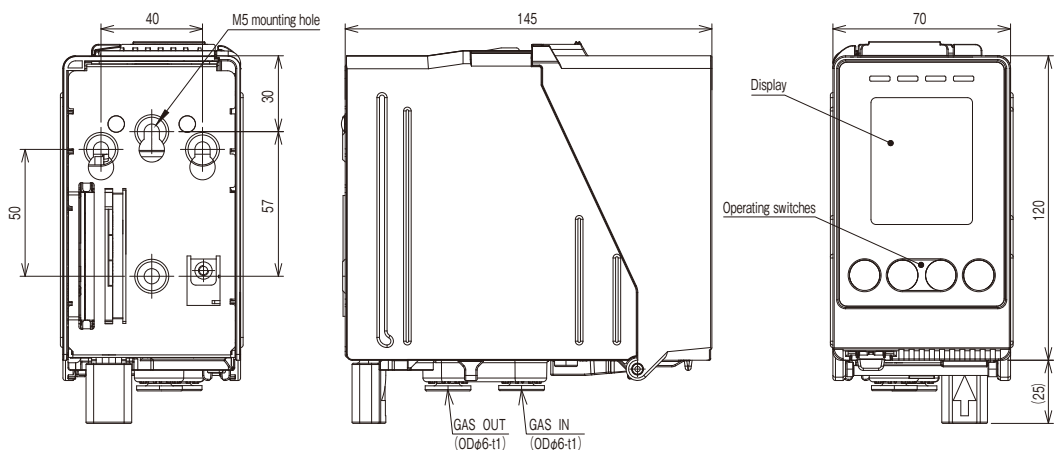

For Ethernet communication
GD-81D-ETD

2-in-1

Greater space and cost savings

Using the M sensor allows two different toxic gases to be detected simultaneously with a single unit. Dramatically reduces installation space requirements and installation costs.

Reduced installation space

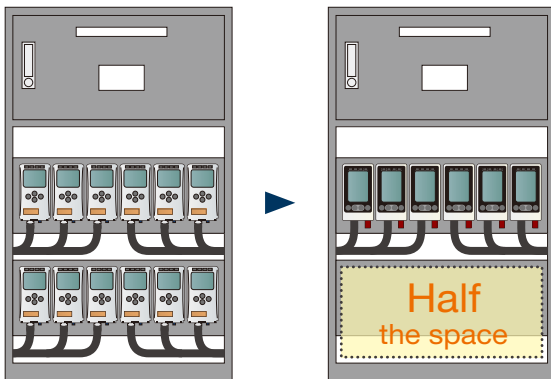

Reduced piping/wiring installation costs

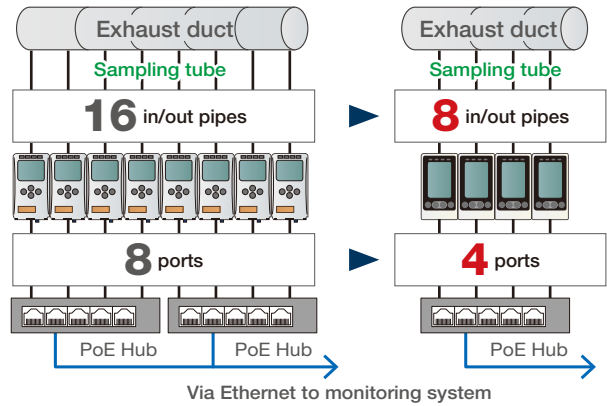

Reduced consumables replacement costs

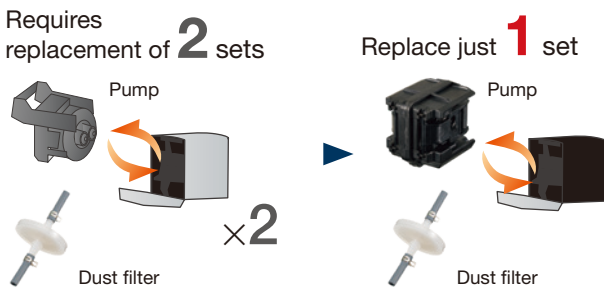

Quieter, longer-lasting pump

Model: RP-80

Two-diaphragm construction minimizes vibration and optimized valve profile reduces noise. These improvements ensure a quieter and longer-lasting pump.



Web browser functions

Faster and more easily

The Ethernet interface allows monitoring of gas detector operating status and alarm details via web browser, anywhere. This enables effective management of large semiconductor plants.

Ethernet interface

Using a PoE hub allows power supply via a LAN cable. This greatly reduces installation costs, particularly for electrical installation. The web browser can be used to check the detector operating status, eliminating the need to visit the actual detector location to check alarm details and perform alarm tests.

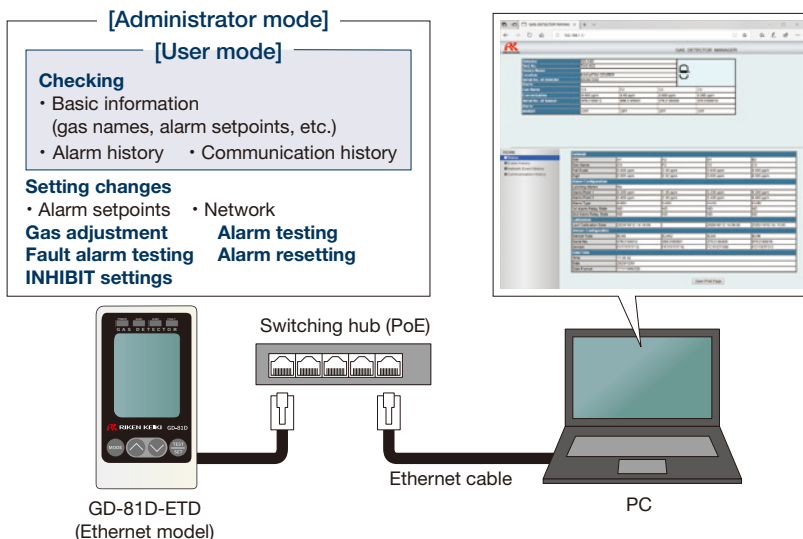

Analog 4–20 mA DC

Gas concentration data is output via a general instrumentation signal (4–20 mA DC), allowing greater flexibility in system configuration.

Pattern 1

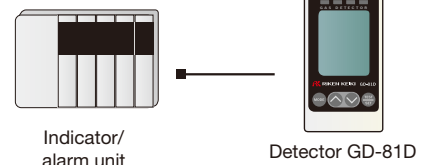

Pattern 2

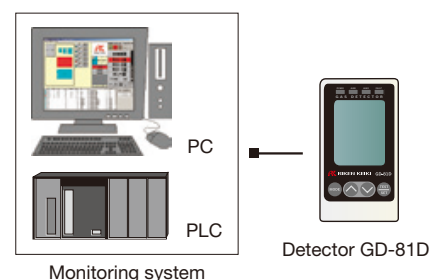

Product specifications

Model	GD-81D	GD-81D-ETD
Detection principles	Catalytic combustion type (NCF, NCU) / semiconductor type (SGF, SGU) / hot-wire semiconductor type (SHF, SHU) / Electrochemical type (ESF, ESU ¹ , M sensor ²) / galvanic cell type (OSU) / infrared type (IRF, IRU) / pyrolysis-particle type (SSU) ³	
Detection target gas	Combustible gas, toxic gas, oxygen, carbon dioxide, etc.	
Concentration display	Full-dot display	
Detection method (suction flow rate)	Pump suction (approx. 0.5 L/min)	
Power supply indication	POWER lamp lit (green)	
Display items	Gas name display, flow rate display, mode display, pyrolyzer connection display ³	
Gas alarm type	Two-step alarm (H-HH) / Oxygen (ESU) sensor: two-step alarm (L-LL) / Oxygen (OSU) sensor: two-step alarm (L-LL, L-H, H-HH)	
Gas alarm indication	First alarm: ALM1 lamp lit (red), second alarm: ALM2 lamp lit (red)	
Gas alarm pattern, fault alarm pattern ⁴	Auto reset / self-latching	
Gas alarm contact, fault alarm contact ⁵	No-voltage contact 1a/1b (for ALM1/ALM2/Fault) Always de-energized (energized in alarm state) or always energized (de-energized in alarm state)	
Fault alarm / self-diagnosis	System abnormality, sensor abnormality, flow abnormality, communication abnormality, pyrolyzer abnormality	
Fault alarm indication	FAULT lamp lit (yellow), information display	
Contact capacity	24 V DC, 0.5 A (resistance load)	
Contact cable	1.25 mm ² (AWG16) cable, max. 6-core	
Transmission method	3-wire analog transmission (common power and signal) / 2-wire analog transmission	Ethernet (10BASE-T / 100BASE-TX)
Transmission cable	Shielded cable 1.25 mm ² (AWG16), 3-core/2-core	Category 5 or better Ethernet cable
Power supply	24 V DC ± 10 %	24 V DC ± 10 % / PoE
Power supply cable	1.25 mm ² (AWG16) cable, 2-core (Not required for 3-wire analog transmission)	1.25 mm ² (AWG16) cable, 2-core (Not required for PoE connection)
Power consumption For ESU/ESF sensors ⁶	Approx. 1.5 W, max. 4.0 W	24 V DC: 2.5 W, max. 4.5 W PoE: 3.5 W, max. 6.5 W
Tube connecting ports	One-touch quick connect coupler, PTFE tube O.D. 6 × I.D. 4 mm (1/4 × 1/8 in) / (1/4 × 3/16 in)	
Functions	White backlight, alarm delay, suppression, zero follower, sensitivity correction, flow control, adjustment history, alarm trend history, event history	
Initialization	Approx. 25 seconds	
Operating temperature / humidity range ⁶	-10 °C to +40 °C (14 °F to 104 °F) (no sudden fluctuations), 0 to 95 %RH (no condensation)	
Construction, exterior color	Wall-mounted type, main unit: black, front door: white	
External dimensions (excluding projections), weight	Approx. 70 (W) × 120 (H) × 145 (D) mm (approx. 2.76 × 4.72 × 5.71 in), approx. 0.8 kg (approx. 1.76 lb)	

Model List

Model	Communication method	Sensor unit	Power supply		Contact output	
			24 V DC	PoE	Gas alarm	Fault alarm
GD-81D	4–20 mA	U sensor unit (NCU, SGU, SHU, ESU, OSU, IRU, SSU) F sensor unit (NCF, SGF, SHF, ESF, IRF)	○	—	○	○
GD-81D-ETD	Ethernet	U sensor unit (NCU, SGU, SHU, ESU, OSU, IRU, SSU) F sensor unit (NCF, SGF, SHF, ESF, IRF) M sensor unit (ESF × 2) ⁷	○ ⁷	○ ⁷	○	○

*1: For certain gas types, a pyrolyzer unit (PLU-80) is used.

*2: The M sensor unit can be used with the GD-81D-ETD. It cannot be used with the GD-81D.

*3: When using the pyrolyzer unit (PLU-80).

*4: Specify when ordering.

*5: With the M sensor is installed, both activate when a gas alarm or fault alarm is issued for either of the two gases.

*6: May vary depending on the sensor installed.

*7: Cannot be powered via a 24 V DC power source and PoE connection at the same time.

RIKEN KEIKI Co., Ltd.

2-7-6 Azusawa, Itabashi-ku, Tokyo 174-8744, Japan

Phone : +81-3-3966-1113

Telefax : +81-3-3558-9110

E-mail : intdept@rikenkeiki.co.jp

Web site : <https://www.rikenkeiki.co.jp/english>

* The contents described in this catalog are subject to change without notice according to the performance improvement.

★ Distributed by: