

**Portable Gas Detector
GX-6100
Operating Manual**

RIKEN KEIKI Co., Ltd.

2-7-6 Azusawa, Itabashi-ku, Tokyo, 174-8744, Japan

Phone : +81-3-3966-1113

Fax : +81-3-3558-9110

E-mail : intdept@rikenkeiki.co.jp

Web site : <https://www.rikenkeiki.co.jp/english/>

Contents	
1 Product Overview	5
1-1 Introduction	5
1-2 Intended use	6
1-3 Checking the detection target gases and product specifications	7
1-4 DANGER, WARNING, CAUTION, and NOTE	9
1-5 Checking standards and explosion-proof specifications	10
2 Important Safety Information	11
2-1 Danger information	11
2-2 Warnings	12
2-3 Precautions	14
2-4 Safety information	19
3 Product Configuration	23
3-1 Main unit and accessories	23
3-1-1 Main unit	23
3-1-2 Accessories	24
3-1-3 Optional accessories	25
3-2 Part names and functions	28
3-2-1 Main unit	28
3-2-2 Battery unit	30
3-2-3 LCD display	31
4 Alarm Functions	32
4-1 Gas alarm types	32
4-2 Gas alarm setpoints	32
4-3 Gas alarm patterns	39
4-4 Fault alarm	42
4-5 Man down alarm	43
4-6 Panic alarm	44
5 Usage Instructions	45
5-1 Usage note	45
5-2 Removing and attaching the battery unit and charging	46
5-2-1 Removing and attaching the battery unit	46
5-2-2 Charging the lithium ion battery unit (BUL-6100)	48
5-2-3 Replacing batteries in the dry battery unit (BUD-6100)	50
5-3 Attaching the tapered nozzle	51
5-4 Turning on the power	52
5-5 Detection modes	57
5-5-1 Normal mode	57
5-5-2 Leak check mode (SHS sensor only)	59
5-5-3 Benzene select mode (VOC sensor (10.0 eV) only)	61
5-6 Performing fresh air adjustment	66
5-7 Gas detection	69
5-7-1 Measuring gas concentration	73
5-7-2 Combustible gas concentration range changeover points	75
5-7-3 Confirmation beep operation	76
5-8 Recording gas concentration logs (snap logger)	77

5-9 Turning off the power.....	78
6 Settings (Display Mode).....	79
6-1 Display mode items	79
6-2 Switching to display mode	85
6-3 Checking settings	86
6-3-1 Displaying/clearing the peak value	86
6-3-2 Displaying the snap logger (gas concentration/alarm status).....	87
6-3-3 Displaying alarm setpoints	88
6-4 Display mode settings.....	89
6-4-1 Setting the combustible gas sensor range.....	89
6-4-2 Combustible gas conversion gas selection.....	90
6-4-3 Switching to benzene select mode	92
6-4-4 Volatile organic compound (VOC) conversion gas selection	95
6-4-5 Setting the user ID	97
6-4-6 Setting the station ID	98
6-4-7 LCD inversion setting	99
6-4-8 LCD background setting.....	100
6-4-9 Peak bar display setting.....	101
6-4-10 Measurement gas scroll setting	102
6-4-11 Setting a Bluetooth device connection.....	103
6-4-12 Setting the buzzer volume	104
6-4-13 Switching display language to Japanese (Japan Ex model)	105
6-4-14 Switching display language to English (ATEX/IECEx model)	106
7 Settings (User Mode)	107
7-1 User mode display items	107
7-2 Switching to user mode	110
7-3 Gas alarm settings.....	112
7-3-1 Setting alarm setpoints.....	112
7-3-2 Setting alarm pattern.....	115
7-3-3 Resetting alarm setpoints	116
7-3-4 Alarm silence setting	117
7-3-5 Leak alarm silence setting	118
7-3-6 Disabling the gas alarm function.....	119
7-4 Man down alarm and panic alarm settings.....	120
7-4-1 Enabling/disabling the man down alarm	120
7-4-2 Enabling/disabling the panic alarm	121
7-4-3 Setting the man down alarm times.....	122
7-5 Other user mode settings	123
7-5-1 Enabling/disabling CO ₂ fresh air adjustment	123
7-5-2 Setting the date and time	124
7-5-3 Setting the date format	125
7-5-4 Setting the display language.....	126
7-5-5 Displaying version information	127
8 Maintenance.....	129
8-1 Maintenance intervals and items	129
8-2 Performing gas adjustment.....	131
8-2-1 Preparation for gas adjustment.....	131
8-2-2 Performing fresh air adjustment.....	136
8-2-3 Performing CO ₂ zero adjustment	138

8-2-4 Setting span adjustment.....	142
8-2-5 Performing span adjustment	148
8-3 Performing bump tests.....	151
8-4 Performing alarm tests.....	153
8-5 Cleaning procedure	154
8-6 Parts replacement.....	155
8-6-1 Periodic replacement parts	155
8-6-2 Dust filter replacement	157
8-6-3 Interference gas removal filter replacement	158
8-6-4 VOC sensor maintenance	159
9 Storage and Disposal	164
9-1 Procedures for storage or when not in use for extended periods	164
9-2 Procedures for use after storage	165
9-3 Product disposal	165
10 Troubleshooting.....	166
10-1 Product abnormalities	166
10-2 Reading abnormalities	170
11 Product Specifications.....	171
11-1 Main unit specifications	171
11-2 Sensor specifications.....	173
11-2-1 Combustible gas sensors.....	173
11-2-2 Carbon dioxide sensors	179
11-2-3 Oxygen sensor	180
11-2-4 Toxic gas sensors	181
11-2-5 VOC sensors	184
12 Appendix.....	185
12-1 Data logger function.....	185
12-2 100 %LEL conversion list	187
12-3 Zero suppression function	188
12-4 Zero follower function	189
12-5 List of interference gases for electrochemical type sensors	190
12-6 Radio law certification.....	194
12-7 Warranty policy	197

1

Product Overview

1-1 Introduction

Thank you for purchasing the GX-6100 Portable Gas Detector ("the product" hereinafter).

The product should be used only by fully-trained personnel.

Maintenance procedures described in this manual should be performed only by fully-trained personnel.

Any maintenance procedure not described in this manual must be performed by RIKEN KEIKI or our certified service engineers. Please contact RIKEN KEIKI.

This operating manual describes product operating procedures and specifications. It provides information essential to correct use of the product.

Make sure you have read and fully understood the contents of this manual before using the product.

Keep this operating manual on hand to allow ready reference during use.

The contents of this manual are subject to change without notice to allow product improvements. Any duplication or reproduction of this manual without permission is prohibited, whether in whole or in part.

Also refer to the corresponding manuals when using the following related programs:

- Operating Manual for RK Link*1, a dedicated app for the portable gas detector (PT9E-022)
- SW-GX-6100 Data Logger Management Program*2 Operating Manual (PT0E-237)
- MT-GX-6100 Configuration Program*3 Operating Manual (PT0E-221)

*1: Can be installed on a smartphone from Google Play or App Store free of charge.

*2: Can be installed on a PC from the separately sold CD-ROM.

*3: Can be installed on a PC from the RIKEN KEIKI website.

RIKEN KEIKI accepts no liability for accidents or damage resulting from use of the product, whether within or outside the warranty period.

Be sure to read the warranty policy described in '12-7 Warranty policy'.

<Models covered by this operating manual>

Before using the product, please confirm that the model of the product you purchased matches the model of the product covered by this operating manual.

- GX-6100

The product includes Bluetooth® functionality. If the function is enabled (selected at the time of purchase), turning the setting on allows communication with a smartphone on which the RK Link app has been installed.

Google Play is a trademark of Google LLC.

App Store is a service mark of Apple Inc.

Bluetooth® is a registered trademark of Bluetooth SIG, Inc. and is used by RIKEN KEIKI under license.

1-2 Intended use

This product is a multi-gas detector capable of detecting combustible gases (%LEL, vol%), oxygen (O₂) (oxygen deficiency, excess oxygen), carbon monoxide (CO), hydrogen sulfide (H₂S), carbon dioxide (CO₂), ammonia (NH₃), chlorine (Cl₂), phosphine (PH₃), sulfur dioxide (SO₂), nitrogen dioxide (NO₂), hydrogen cyanide (HCN), and volatile organic compounds (VOCs) in air, and high concentrations of combustible gases (vol%) and oxygen (O₂) in nitrogen (N₂) or in inert gases.

Up to six different gas concentrations can be measured using a single unit, and the alarm function triggers an alarm if the gas concentration reaches or exceeds the alarm setpoints.

The product is capable of measuring methane (CH₄), commonly used in factories and on oil tankers, and general combustible isobutane (HC (i-C₄H₁₀)) gas.

Note that the measurement results provided by the product do not constitute a guarantee with respect to life or safety.

Check again the specifications before use to perform gas measurement correctly in accordance with the intended purpose.

The following sensors can be installed in the product:

Sensor type	Detection principle	Sensor model	
Combustible gas sensor	NCR sensor	New ceramic type	NCR-6309 (CH ₄ /HC (i-C ₄ H ₁₀)) [%LEL]
	DES sensor	Non-dispersive infrared type (NDIR)	DES-3311-2 (HC (i-C ₄ H ₁₀)) [%LEL/vol%] DES-3311-3 (CH ₄) [%LEL/vol%]
	SHS sensor	Hot-wire semiconductor type	SHS-8661 (CH ₄ , HC (i-C ₄ H ₁₀)) [ppm]
	TE sensor	Thermal conductivity type	TE-7561 (CH ₄) [vol%]
Oxygen (O ₂) sensor	ESR sensor	Electrochemical type	ESR-X13P (O ₂)
Toxic gas sensor	ESR sensor	Electrochemical type	ESR-A1DP (H ₂ S/CO) ESR-A13i (H ₂ S) ESR-A1CP (CO) (reduced H ₂ interference) ¹ ESR-A13P (CO)
	ESS sensor	Electrochemical type	ESS-03DH (SO ₂) ESS-03DH (NO ₂) ESS-03DH (HCN) ESS-B332 (NH ₃) ESS-B335 (Cl ₂) ESS-03DH (PH ₃)
VOC ² sensor	PIS sensor	Photoionization type (PID)	PIS-001A (VOC, 10.6 eV) [ppb] PIS-002A (VOC, 10.6 eV) [ppm] PIS-003 (VOC, 10.0 eV) [ppm]
Carbon dioxide (CO ₂) sensor	DES sensor	Non-dispersive infrared type (NDIR)	DES-3311-1 (CO ₂) [vol%] DES-3311-4 (CO ₂) [ppm]

*1: The carbon monoxide sensor (ESR-A1CP) includes a correction function to reduce hydrogen interference. This function works for hydrogen concentrations up to 2,000 ppm. However, if used in environments exceeding 40 °C for more than 15 minutes, it may be affected by hydrogen interference and indicate a higher concentration than the actual carbon monoxide level.

*2: Volatile Organic Compound

1-3 Checking the detection target gases and product specifications

The detection target gases vary depending on the particular sensors installed in the product. Check the detection target gases using the product code before use.

The alphanumeric product codes for the product are categorized as follows:

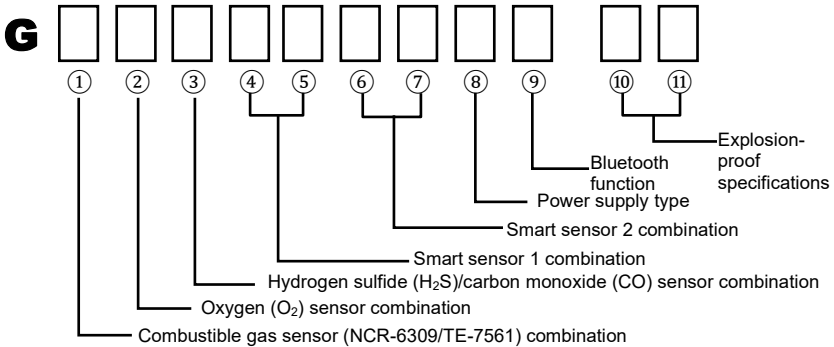

①: Combustible gas sensor (NCR-6309/TE-7561) combination

Code	Sensor model (detection target gas)
0	N/A (dummy sensor)
M	NCR-6309 (CH ₄) [%LEL]
H	NCR-6309 (HC (i-C ₄ H ₁₀)) [%LEL]
D	NER-6309 (CH ₄) [%LEL] + TE-7561 (CH ₄) [vol%]
V	TE-7561 (CH ₄) [vol%]

②: Oxygen (O₂) sensor combination

Code	Sensor model (detection target gas)
0	N/A (dummy sensor)
1	ESR-X13P (O ₂)

③: Hydrogen sulfide (H₂S)/carbon monoxide (CO) sensor combination

Code	Sensor model (detection target gas)
0	N/A (dummy sensor)
1	ESR-A1DP (H ₂ S/CO)
2	ESR-A13i (H ₂ S)
3	ESR-A1CP (CO)*
4	ESR-A13P (CO)

* The carbon monoxide sensor (ESR-A1CP) includes a correction function to reduce hydrogen interference. This function works for hydrogen concentrations up to 2,000 ppm. However, if used in environments exceeding 40 °C for more than 15 minutes, it may be affected by hydrogen interference and indicate a higher concentration than the actual carbon monoxide level.

④⑤ and ⑥⑦: Smart sensor combinations

Code	Sensor model (detection target gas)
00	N/A (dummy sensor)
P1	PIS-001A (VOC, 10.6 eV) [ppb]
P2	PIS-002A (VOC, 10.6 eV) [ppm]
P3	PIS-003 (VOC, 10.0 eV) [ppm]
D1	DES-3311-1 (CO ₂) [vol%]
D2	DES-3311-2 (HC (i-C ₄ H ₁₀)) [%LEL/vol%]
D3	DES-3311-3 (CH ₄) [%LEL/vol%]
D4	DES-3311-4 (CO ₂) [ppm]
E1	ESS-03DH (SO ₂)
E2	ESS-03DH (NO ₂)
E3	ESS-03DH (HCN)
E4	ESS-B332 (NH ₃)
E5	ESS-B335 (Cl ₂)
E6	ESS-03DH (PH ₃)
S1	SHS-8661 (CH ₄) [ppm]
S2	SHS-8661 (HC (i-C ₄ H ₁₀)) [ppm]

⑧: Power supply type

Code	Specifications
L	Lithium ion battery unit BUL-6100
D	Dry battery unit BUD-6100

⑨: Bluetooth function

Code	Specifications
0	Not Bluetooth compatible
1	Bluetooth compatible

⑩⑪: Explosion-proof specifications

Code	Specifications
00	Japan Ex
50	ATEX/IECEX



<Example product codes>

The table below shows example product codes and their respective specifications.

Example product code		GM11P1D1L1 00	G004D400D0 50
Combustible gas sensor		NCR-6309 (CH ₄ , %LEL)	Not installed
Oxygen sensor		ESR-X13P (O ₂)	Not installed
Toxic gas sensor		ESR-A1DP (H ₂ S/CO)	ESR-A13P (CO)
Smart sensor	1	PIS-001A (VOC, 10.6 eV) [ppb]	DES-3311-4 (CO ₂) [ppm]
	2	DES-3311-1 (CO ₂) [vol%]	Not installed
Power supply type		Lithium ion battery unit BUL-6100	Dry battery unit BUD-6100
Bluetooth function		Compatible	Not compatible
Explosion-proof specifications		Japan Ex	ATEX/IECEX

1-4 DANGER, WARNING, CAUTION, and NOTE

This operating manual uses the following categories to indicate potential damage/hazards if the user disregards the information provided and uses the product incorrectly:

 DANGER	This indicates situations in which improper handling may result in fatal or serious injury or significant property damage.
 WARNING	This indicates situations in which improper handling may result in serious injury or significant property damage.
 CAUTION	This indicates situations in which improper handling may result in minor injury or minor property damage.

Additionally, usage recommendations are indicated as follows:

NOTE	This indicates items that will be helpful to know when using the product.
-------------	---------------------------------------------------------------------------

1-5 Checking standards and explosion-proof specifications

The product specifications will vary depending on the specific standards and explosion-proof certification. Check the actual product specifications before use. Check the affixed nameplate for product specifications.

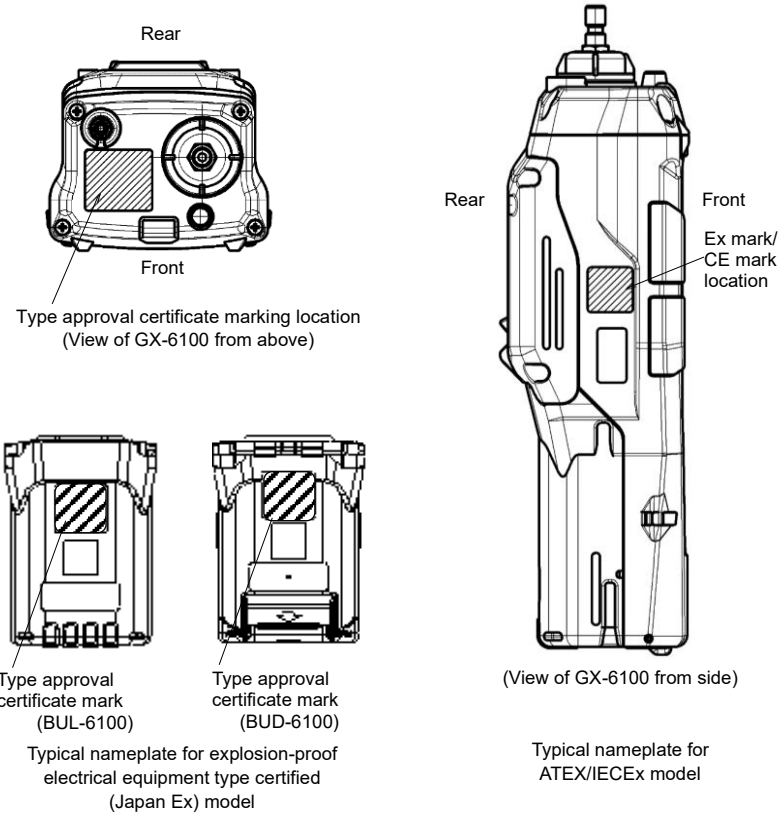

2

Important Safety Information

To maintain the performance of the product and to ensure safe use, always observe the following DANGER, WARNING, and CAUTION instructions.

2-1 Danger information



DANGER

Explosion-proofing

- Do not modify or alter the circuits or configuration.
- When carrying and using the product in hazardous areas, the following general precautions must be observed to safeguard against static electricity hazards:
 - Wear anti-static clothing and conductive shoes (anti-static work shoes).
 - When using the product indoors, stand on a conductive work floor (with a leakage resistance of 10 MΩ or less).
- The product is explosion-proof. With the exception of specified components, it cannot be disassembled or modified.
- Do not subject the buzzer opening on the main unit to impact.
- For information on explosion-proof certification and precautions, refer to '2-4 Safety information'.

Usage

- If measuring inside manholes or enclosed spaces, never lean over or look into the manhole or enclosed space. There is a danger that oxygen-deficient air or other gases may be discharged from such locations.

Gas outlet

- Oxygen-deficient air or other gas may be discharged from the gas outlet. Never breathe in this air.
 - High-concentration (100 %LEL or higher) gas may be discharged. Be sure to maintain a safe distance from flame sources.
-

2-2 Warnings



WARNING

If an abnormality occurs

- Contact RIKEN KEIKI immediately. Visit our website for information on the nearest RIKEN KEIKI office.
Website: <https://www.rikenkeiki.co.jp/>

Sampling point pressure

- The product is designed to draw in gas at atmospheric pressure. There is a danger that detection target gas may leak from inside the product if an excessive pressure is applied to the gas inlet (GAS IN) or outlet (GAS OUT) of the product. Be careful to avoid excessive pressure during use.
- Do not connect the tapered nozzle directly to locations at a pressure greater than atmospheric pressure. Doing so may result in damage to the internal piping.

Sensor handling

- Never disassemble the sensor.
Electrochemical type sensors in particular contain hazardous electrolyte. Contact with electrolyte may result in skin inflammation. Contact with eyes may result in blindness. Contact with clothing may result in discoloration or damage to the fabric.
If contact occurs, rinse the area immediately with plenty of water.
- Do not use any gas other than nitrogen (N₂) as the balance gas when adjusting the oxygen sensor. Otherwise, oxygen (O₂) reading errors will increase, preventing accurate measurement.

Fresh air adjustment in surrounding atmosphere

- When fresh air adjustment is performed in the surrounding atmosphere, check the air for cleanliness before starting. The presence of miscellaneous or interference gases will make it impossible to adjust the product correctly, resulting in the danger of erroneous detection when actual gas leaks occur.

Action if a gas alarm occurs

- A gas alarm indicates an extreme hazard. The user must take appropriate action after taking appropriate steps to ensure safety.

Man down alarm and panic alarm

- The man down and panic alarms are intended to assist the user and those in the vicinity to make appropriate decisions. They are not intended to assure life or safety. Do not depend solely on this function when using the product.
- The man down and panic alarms are initially disabled and unavailable. To use these functions, enable the settings. For information on how to configure the settings, see '7-4-1 Enabling/disabling the man down alarm'.

Battery level check

- Check the battery level before using the product. The batteries may be depleted when the product is used for the first time or after extended periods without use. Always fully charge or replace with new batteries before use.
- Gas measurement will not be possible if a battery low voltage alarm occurs. If the alarm occurs during use, turn off the power and promptly charge or replace the batteries in a safe place.

Miscellaneous

- Do not use the product in rain or submerge it in water. Doing so may cause water to enter the product, resulting in the failure of the sensors or the product. Even if this does not result in failure, a wet sensor may be unable to detect gases.
 - When using the product, always make that the product is able to suck in air. If the product inlet is covered or blocked, correct measurement cannot be obtained, possibly leading to accidents.
 - Do not leave the product at temperatures -10 °C or below for extended periods. Doing so may cause the pump valve to freeze, disabling normal operation of the pump.
 - Do not dispose of the product into fire.
 - Do not attempt to wash the product, either in a washing machine or an ultrasonic cleaning machine.
 - Do not block the buzzer sound opening. Doing so will muffle or silence the audible warning.
 - Do not remove the battery unit while the power is turned on.
-

2-3 Precautions



CAUTION

Avoid use in locations where oil or chemicals may splash. Avoid deliberately submerging the product in water.

- Avoid using the product in locations where the product may be splashed with liquids such as oil and chemicals.
- The product is not designed to be water pressure resistant. Avoid exposing the product directly to water from a faucet or shower as water may get in the product if it is subjected to water pressure. Note that the product is waterproof against freshwater and tap water, but it is not waterproof against hot water, saltwater, detergent, chemicals, or perspiration.
- The gas inlet (GAS IN) and outlet (GAS OUT) are not waterproof. Take care to prevent water such as rainwater from entering these parts. Failure to do so may prevent gas measurement.
- Do not place the product in locations where water or dirt accumulates. Placing the product in such locations may cause malfunction due to water or dirt ingress into the buzzer sound opening or gas inlet (GAS IN), etc.
- The sensor sensitivity will be significantly reduced if dirty water, dust, or metal particles are drawn in. Take adequate care when using in such environments.
- The dustproof and waterproof construction IP67 rating does not imply that the product is capable of detecting gas while or after being subjected to such environmental conditions. Be sure to remove any dust or water before use.

Do not use the product in locations outside the operating temperature range.

- Avoid using or storing the product at temperatures outside the operating temperature range.
- Avoid using the product for extended periods in locations where it is exposed to direct sunlight.
- Avoid storing the product inside parked vehicles in hot weather.

Adhere to the operating humidity range to prevent condensation forming inside the product or tapered nozzle.

- Condensation forming inside the product or tapered nozzle may cause clogging or gas adsorption, which may prevent accurate gas measurement. Condensation must be avoided at all costs. In addition to the usage environment, carefully monitor the temperature and humidity of the sampling point to prevent condensation forming inside the product.

Do not use walkie-talkies near the product.

- Radio waves from walkie-talkies or other radio transmitters near the product may affect readings. If walkie-talkies or other radio wave transmitting devices are used, these must be used away from the product where they do not affect operation.
- Do not use the product near devices that emit strong electromagnetic radiation (high-frequency or high-voltage devices).

Verify that the flow confirmation icon is rotating.

- Correct gas measurement is not possible if the flow confirmation icon is not rotating. Check to confirm that the suction is operating correctly.

Verify that the operating status icon is blinking.

- If the operating status icon on the LCD is not blinking, gas cannot be measured correctly. (See '3-2-3 LCD display'.)

Be sure to perform regular maintenance.

- The product is a safety device and must be regularly maintained without fail. Continuing to use the product without maintenance will result in sensor sensitivity variations, preventing accurate gas measurement.

Miscellaneous

- Pressing buttons unnecessarily may change the settings, preventing alarms from activating correctly. Avoid performing any operations not described in this operating manual.
- Do not drop the product or subject it to impact. Doing so may degrade explosion-proof, waterproof, dustproof, and gas detection performance.
- A fault alarm may be triggered if the product is subjected to strong impact. If this occurs, turn the power off and then back on again, then perform a bump test to confirm that the product functions correctly before use.
- The impact resistance of the product is not a guarantee against damage or failure. Dropping the product may affect readings. We recommend performing inspection including gas adjustment if it has been dropped.
- Do not use the product while charging it.
- Do not prod the buzzer sound opening with sharp objects. Doing so may result in malfunctions or damage to the product and allow foreign matter inside.
- Do not remove the panel sheet on the LCD. Doing so will impair dustproof performance.

Sensors

- Do not expose the product to sudden pressure fluctuations. Oxygen (O₂) readings will vary temporarily, preventing accurate measurement.
- If highly adsorptive gas has been sucked in, allow the product to suck in clean air, and confirm that the reading returns to zero before use.
- Some sensors may exhibit positive sensitivity to gases other than the detection target gas. Note that when the product is used in an environment where such gases are present, the reading may be higher than the actual concentration of the detection target gas present.

<Examples of interference gases to which the sensor exhibits positive sensitivity>

Sensor type	Detection target gas name	Interference gas
NCR sensor (New ceramic type)	Methane (CH ₄)/ isobutane (HC (i-C ₄ H ₁₀))	All combustible gases
DES sensor (Non-dispersive infrared type (NDIR))	Methane (CH ₄)/ isobutane (HC (i-C ₄ H ₁₀))	Hydrocarbon combustible gases
SHS sensor (Hot-wire semiconductor type)	Methane (CH ₄)/ isobutane (HC (i-C ₄ H ₁₀))	All gases
TE sensor (Thermal conductivity type)	Methane (CH ₄)/ isobutane (HC (i-C ₄ H ₁₀))	All combustible gases
ESS sensor (Electrochemical type)	Hydrogen cyanide (HCN)	Hydrogen sulfide (H ₂ S)
ESS sensor (Electrochemical type)	Hydrogen cyanide (HCN)	Sulfur dioxide (SO ₂)
ESS sensor (Electrochemical type)	Hydrogen cyanide (HCN)	Acetylene (C ₂ H ₂)
ESS sensor (Electrochemical type)	Hydrogen cyanide (HCN)	Phosphine (PH ₃)
ESS sensor (Electrochemical type)	Sulfur dioxide (SO ₂)	Hydrogen (H ₂)
ESS sensor (Electrochemical type)	Sulfur dioxide (SO ₂)	Carbon monoxide (CO)
ESS sensor (Electrochemical type)	Carbon monoxide (CO)	Hydrogen (H ₂)

ESS sensor (Electrochemical type)	Chlorine (Cl ₂)	Sulfur dioxide (SO ₂)
ESS sensor (Electrochemical type)	Chlorine (Cl ₂)	Hydrogen chloride (HCl)
ESS sensor (Electrochemical type)	Phosphine (PH ₃)	Sulfur dioxide (SO ₂)
ESS sensor (Electrochemical type)	Phosphine (PH ₃)	Hydrogen cyanide (HCN)
ESS sensor (Electrochemical type)	Phosphine (PH ₃)	Hydrogen sulfide (H ₂ S)
PIS sensor (Photoionization type (PID))	Volatile organic compounds (VOCs)	All volatile organic compounds (VOCs)

- Using the ESR-A1CP for the carbon monoxide sensor reduces interference at hydrogen concentrations up to 2,000 ppm.
- Due to their operating principle, electrochemical type sensors may exhibit negative sensitivity to certain interference gases. In environments where interference gases are present, the reading may be lower than the actual concentration of the detection target gas present, and particularly at high concentrations, the reading may even turn negative, triggering an M OVER alarm. (See '12-5 List of interference gases for electrochemical type sensors'.)
- Note that if new ceramic type or hot-wire semiconductor type combustible gas sensors are used in an environment where silicone compounds, halides, high-concentration sulfides, or high-concentration solvent gases are present, sensor life may be reduced, sensitivity to combustible gases may deteriorate, and accurate readings may not be obtained.
If use in such environments is unavoidable, use for the shortest possible time and allow the product to suck in fresh air afterward. Confirm that the reading returns to normal and is stabilized.
Contact with high concentrations of solvent gas may damage the product. Avoid use in situations where it may come into contact with high concentrations of solvent gas.
- An oxygen concentration of at least 10 vol% is required in order for the new ceramic type combustible gas sensor (%LEL) in the product to accurately measure and display gas concentrations.
- Due to the way the sensor operates, an accurate reading may not be displayed immediately after turning on the power. Allow the product to warm up for at least one minute after turning on the power to allow the reading to stabilize before use. Allow the product to warm up for at least 10 minutes after turning on the power before performing gas adjustment.
- The reading of the carbon monoxide sensor may rise if exposed to high concentrations of volatile organic compounds (VOCs). If the reading rises and will not return, the activated carbon filter in the carbon monoxide sensor must be replaced. For information on activated carbon filter replacement, contact RIKEN KEIKI.
- Due to the properties of the gases, response to chlorine (Cl₂) and ammonia (NH₃) may slow near the lower limit (around -20 °C) of the operating temperature range.
- The zero point for carbon monoxide and hydrogen sulfide sensors may fluctuate at low or high temperatures. If this occurs, perform fresh air adjustment in the ambient atmosphere.
- The hydrogen sulfide sensor may exhibit temporary fluctuations if exposed to sudden temperature variations. Allow the product to stand and acclimatize in the ambient atmosphere before use.
- If the VOC sensor is exposed to high concentrations of methane (CH₄), ethane (C₂H₆), propane (C₃H₈), or other gases, [----] may appear in the concentration display area, and measurement may be temporarily disabled. In environments where these gases are present, even if the concentration display does not indicate [----], be aware that the VOC concentration may not be accurately measured. Even if the VOC sensor concentration display indicates [----], other unaffected sensors can continue measurement.

<Example interference gases causing [----] to be displayed in the VOC sensor concentration display area>

Interference gas	Concentration
Methane (CH ₄)	6 vol% or more
Ethane(C ₂ H ₆)	80 vol% or more
Propane (C ₃ H ₈)	90 vol% or more

Battery replacement

- Be sure to turn off the power for the product before replacing the batteries.
- When replacing the batteries, replace all three with new batteries at the same time.
- The following batteries must be used to ensure that the product meets explosion-proof standards.
(Applies only when using the dry battery unit.)
Japan Ex model: Toshiba AA alkaline batteries (LR6T (JE)) × 3
ATEX/IECEx model: Toshiba AA alkaline batteries (LR6T (JE)) × 3 or Duracell batteries (MN1500) × 3
- Note the polarity of the batteries.

Usage

- The operating time will be reduced due to battery performance in cold environments.
- The response of the LCD may slow at low temperatures.
- Always perform fresh air adjustment under conditions of pressure, temperature, and humidity similar to those in the usage environment and in clean air.
- Wait for the reading to stabilize before performing fresh air adjustment.
- If there is a temperature difference of 15 °C or more between the storage and usage locations, turn on the power and allow the product to stand for about 10 minutes in a similar environment to the usage location to acclimatize before performing fresh air adjustment in clean air.
- Do not use water or organic solvents such as alcohol or benzene when wiping the product. Doing so may discolor or damage the surfaces of the product.
- Even if the product is not used for extended periods, turn the power on at least once every six months to check pump suction (by running the product for approximately three minutes). Grease inside the pump motor may solidify and prevent operation if the product is not operated for extended periods.
- After an extended period of storage, be sure to perform fresh air adjustment before resuming use. For information on readjustment including fresh air adjustment, contact RIKEN KEIKI.
- Do not use the product in locations where the following miscellaneous gases are present:

<Gases affecting sensor sensitivity>

Sensor type	Miscellaneous gas type
NCR sensor (New ceramic type)	<ul style="list-style-type: none"> • Organic silicone gases such as D4 siloxane and D5 siloxane, sulfur gases such as SO_x and hydrogen sulfide (H₂S) at concentrations that exceed the detection range of the sensors mounted at the same time • Polymer substances such as ethylene oxide (C₂H₄O), acrylonitrile (C₃H₃N), butadiene (C₄H₆), and styrene (C₈H₈) • Catalyst poisons such as phosphorous compounds, halogenated hydrocarbon, and metallic vapors <p>* The extent of the effect depends on the sensor model.</p>
DES sensor (Non-dispersive infrared type (NDIR))	N/A
SHS sensor (Hot-wire semiconductor type)	<ul style="list-style-type: none"> • High-concentration sulfides (e.g., H₂S, SO₂) • Halogen gases (e.g., chlorine compounds) • Silicone (Si compounds)
TE sensor (Thermal conductivity type)	N/A
ESS/ESR sensor (Electrochemical type)	Differs depending on the sensor.

<Sensor-corroding gases>

Sensor type	Miscellaneous gas type
NCR sensor (New ceramic type)	Corrosive gases such as SO _x and NO _x and acidic gases such as hydrogen fluoride (HF) and hydrogen chloride (HCl)
DES sensor (Non-dispersive infrared type (NDIR))	Corrosive gases such as SO _x and NO _x and acidic gases such as hydrogen fluoride (HF) and hydrogen chloride (HCl)
SHS sensor (Hot-wire semiconductor type)	Corrosive gases such as SO _x and NO _x and acidic gases such as hydrogen fluoride (HF) and hydrogen chloride (HCl)
TE sensor (Thermal conductivity type)	High-concentration organic gases and high-concentration alcohol (C ₂ H ₆ O)
ESS/ESR sensor (Electrochemical type)	N/A

- Take care when using the product in locations where the following interference gases are present.

Sensor type	Miscellaneous gas type
NCR sensor (New ceramic type)	Hydrocarbons, alcohol (C ₂ H ₆ O), organic solvents, etc. other than the target gas
DES sensor (Non-dispersive infrared type (NDIR))	Combustible gas sensor: Hydrocarbons, alcohol (C ₂ H ₆ O), organic solvents, water (H ₂ O), etc. other than the target gas Carbon dioxide sensor: High-concentration carbon monoxide (CO), nitrous oxide (N ₂ O), nitrogen monoxide (NO), etc.
TE sensor (Thermal conductivity type)	Organic gases, alcohol (C ₂ H ₆ O), carbon dioxide (CO ₂), and argon (Ar)
SHS sensor (Hot-wire semiconductor type)	Hydrocarbons, alcohol (C ₂ H ₆ O), organic solvents, water (H ₂ O), etc. other than the target gas
ESS/ESR sensor (Electrochemical type)	Differs depending on the sensor.

2-4 Safety information

The GX-6100 can be equipped with up to six types of sensors to enable detection of up to six different gas types.

Four sensors are used to detect combustible gas (%LEL, vol%), oxygen (O₂), hydrogen sulfide (H₂S), and carbon monoxide (CO).

The GX-6100 combustible gas sensor (%LEL) satisfies “da” requirements. A hot-wire semiconductor type sensor can also be installed to detect combustible gas in the ppm range. A thermal conductivity type sensor can also be used to detect combustible gas in the vol% range. The GX-6100 uses these three sensor types to enable it to detect combustible gas in the ppm, %LEL, and vol% ranges.

The remaining two slots are for smart sensors each of which consists of a sensor unit and PCB and is connected to the GX-6100 through its digital signal output. The smart sensors available are based on five different detection principles. Up to two smart sensors can be fitted to the GX-6100.

Gas is drawn in using a built-in micro pump.

Either the BUD-6100 alkaline dry battery unit or the BUL-6100 lithium ion battery unit can be installed. The battery units are designed so that they can be swapped by the user.

Carry out battery unit replacement, alkaline battery replacement, and rechargeable battery charging in a location free of any hazards.

The BUL-6100 can be charged using either the dedicated BC-6000 charger or the SDM-6100 bump tester.

<Japan Ex models>

Explosion-proof class

Main unit	Ex da ia IIC T4 Ga (with new ceramic type sensor installed) Ex ia IIC T4 Ga (without new ceramic type sensor installed)
Lithium ion battery unit BUL-6100	Ex ia IIC T4 Ga
Dry battery unit BUD-6100	Ex ia IIC T4 Ga

Compliant explosion-proofing guidelines: Recommended Practices for Explosion-Protected Electrical Installations in General Industries

Main unit	JNIOSH-TR-46-1: 2020 JNIOSH-TR-46-2: 2018 JNIOSH-TR-46-6: 2015
Battery units	JNIOSH-TR-46-1: 2020 JNIOSH-TR-46-6: 2015

Rating (power source)

Main unit	<ul style="list-style-type: none"> • Model with user-replaceable battery unit BUL-6100 (with two Panasonic NCR18650GA rechargeable lithium cells arranged in parallel) or • Model with user-replaceable battery unit BUD-6100 (with three Toshiba LR6T (JE) AA alkaline batteries arranged in series)
Lithium ion battery unit BUL-6100	With two Panasonic NCR18650GA rechargeable lithium cells arranged in parallel
Dry battery unit BUD-6100	With three Toshiba LR6T (JE) batteries (1.5 V × 3 = 4.5 V)

Certificate number

This varies depending on whether or not a new ceramic type sensor is installed and on the detection principles of the smart sensors installed.

Before use, check to confirm that the certificate number is correct for the combination of detection principles for the smart sensors installed in the purchased product.

<Main unit>

New ceramic type sensor	Smart sensor combination	Certificate number
Installed	No smart sensor installed	DEK25.0002
	Electrochemical type only	
	Photoionization type (PID) only	
	Photoionization type (PID) + Electrochemical type	
	Photoionization type (PID) + Infrared type	DEK25.0003
	Infrared type + Electrochemical type	DEK25.0004
	Infrared type + hot-wire semiconductor type	DEK25.0005
	Infrared type only	
Not installed	Hot-wire semiconductor type only	DEK25.0006
	No smart sensor installed	
	Electrochemical type only	
	Photoionization type (PID) only	DEK25.0007
	Photoionization type (PID) + Electrochemical type	
	Photoionization type (PID) + Infrared type	DEK25.0008
	Infrared type + Electrochemical type	
Infrared type only		

<Battery unit>

Battery unit	Certificate number
Lithium ion battery unit BUL-6100	DEK25.0009
Dry battery unit BUD-6100	DEK25.0010

• **Ambient temperature:** -20 °C to +50 °C

(Ambient temperature refers to the temperature range in which the explosion-proof performance can be maintained. It does not refer to the temperature range in which product performance is guaranteed. For information on the operating temperature range, refer to '11-1 Main unit specifications' and '11-2 Sensor specifications'.)



Main unit

- The battery unit can be used only when evaluated in conjunction with this unit and when used in conjunction with a type-approved main unit. The following battery units can be connected:
 - Lithium ion battery unit BUL-6100
 - Dry battery unit BUD-6100

Battery unit

- The lithium ion battery unit is evaluated in conjunction with a main unit and may only be used in conjunction with a type-approved main unit. The following main unit can be connected:
 - GX-6100
- The dry battery unit is evaluated in conjunction with a main unit and may only be used in conjunction with a type-approved main unit. The following main unit can be connected:
 - GX-6100

Lithium ion battery unit

- Do not remove the lithium ion battery unit in hazardous areas.







- The lithium ion battery unit must be charged using the dedicated BC-6000 charger, an IEC 60950 certified SELV power supply, or an IEC 62368-1 certified ES1 power supply.
- The allowable voltage for the battery charging contacts is 17.8 V DC.
- Charge the battery at an ambient temperature between 0 °C and 40 °C.
- Charge using the dedicated BC-6000 charger.

Dry battery unit

- Do not remove the dry battery unit in hazardous areas.
- Do not replace dry batteries in hazardous areas.

<ATEX/IECEx models>

Explosion-proof specifications

GX-6100 explosion-proof class	Ambient temperature range	Combustible gas sensor*	Battery type
 Ex da ia IIC T4 Ga II1G Ex da ia IIB T4 Ga	-20 °C to +50 °C	Installed	BUL-6100
 Ex ia IIC T4 Ga II1G Ex ia IIC T4 Ga	-20 °C to +50 °C	Not installed	BUL-6100
 Ex da ia IIC T4 Ga II1G Ex da ia IIB T4 Ga	-20 °C to +50 °C	Installed	BUD-6100 LR6T (JE) (Toshiba)
 Ex ia IIC T4 Ga II1G Ex ia IIC T4 Ga	-20 °C to +50 °C	Not installed	BUD-6100 LR6T (JE) (Toshiba)
 Ex da ia IIC T3 Ga II1G Ex da ia IIB T3 Ga	-20 °C to +50 °C	Installed	BUD-6100 MN1500 (Duracell)
 Ex ia IIC T3 Ga II1G Ex ia IIC T3 Ga	-20 °C to +50 °C	Not installed	BUD-6100 MN1500 (Duracell)

* "Combustible gas sensor" above refers to a new ceramic type sensor.

Ambient temperature range (when charging)

0 °C to +40 °C

(Ambient temperature refers to the temperature range in which the explosion-proof performance can be maintained. It does not refer to the temperature range in which product performance is guaranteed. For information on the operating temperature range, refer to '11-1 Main unit specifications' and '11-2 Sensor specifications'.)

Electrical specifications

• Lithium ion battery unit power supply: BUL-6100

The BUL-6100 battery pack contains two Panasonic NCR18650GA lithium ion cells arranged in parallel.

It must be charged using the dedicated BC-6000 charger, an IEC 60950 certified SELV power supply, or an IEC 62368-1 certified ES1 power supply.

The power supply voltage must not exceed 17.8 V DC.

• Alkaline dry battery unit power supply: BUD-6100

This uses three AA alkaline batteries (Toshiba type LR6T (JE) or Duracell type MN1500).

Certificate numbers

- IECEx certificate number: IECEx DEK 24.0014
- ATEX certificate number: DEKRA 24 ATEX 0016

Applicable standards

- IEC 60079-0:2017
- IEC 60079-1:2014
- IEC 60079-11:2011
- EN IEC 60079-0:2018
- EN 60079-1:2014
- EN 60079-11:2012

“X” marking conditions

N/A

**DANGER**

- Do not disassemble or modify the product.
- In this product, only the NCR-6309 combustible gas sensor has a flame-proof construction.
- The product is an explosion-proof product. Do not disassemble or modify any parts other than those specified.
- The product contains sensors with a flame-proof construction. If assembly is not performed as specified, explosion protection performance may be compromised. When replacing the filter, correctly install genuine parts and torque to specification.
- If the housing becomes damaged, stop using the product and have it repaired.
- The sensor must not be exposed to ultraviolet light or used in equipment in which it is not fully enclosed.
- Contact RIKEN KEIKI to request readjustment of the product, including gas adjustment, and also parts replacement.

GX-6100 (with BUL-6100)

- Do not replace the battery unit in a hazardous location.
- Do not charge in hazardous areas.
- Charge using the dedicated charger.

GX-6100 (with BUD-6100)

- Do not replace the battery unit in a hazardous location.
- Do not replace dry batteries in a hazardous location.
- For the ATEX/IECEx model, be sure to use AA alkaline batteries (Toshiba type LR6T (JE) or Duracell type MN1500).

Product code

INST. No. 0 0 0 0 0 0 0 0 0 0 0 0
 AB C D E

A: Year of manufacture (0 to 9)

B: Month of manufacture (1 to 9 for January to September, X for October, Y for November, Z for December)

C: Manufacturing lot

D: Serial number

E: Code of factory

**RIKEN KEIKI Co.,Ltd.**

2-7-6, Azusawa, Itabashi-ku, Tokyo, 174-8744, Japan

Phone : +81-3-3966-1113

Fax : +81-3-3558-9110 GIII

E-mail : intdept@rikenkeiki.co.jpWeb site : <http://www.rikenkeiki.co.jp>

3

Product Configuration

3-1 Main unit and accessories

Open the box and packaging and inspect the main unit and accessories.
If any accessories or parts are missing, contact RIKEN KEIKI.

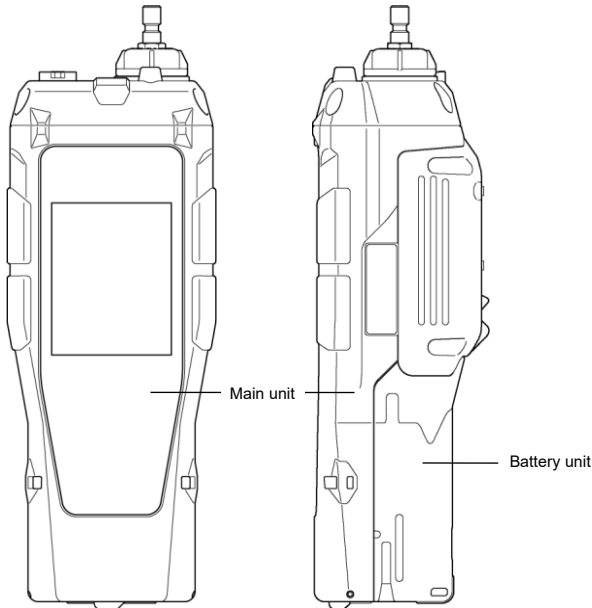

3-1-1 Main unit

For detailed information on the product part names and functions and the LCD display, see '3-2 Part names and functions'.



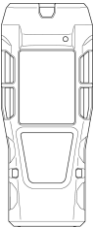
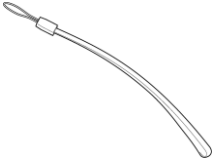
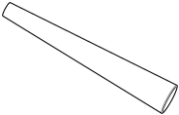
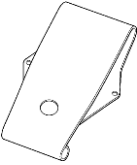
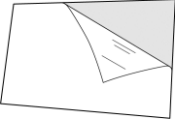
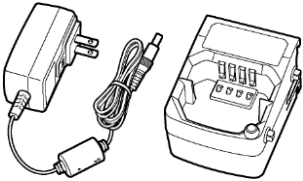
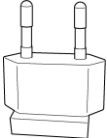

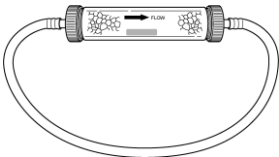

3-1-2 Accessories



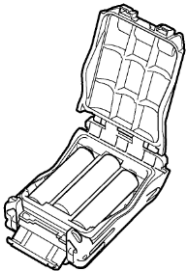

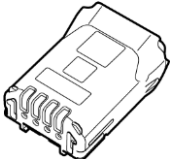
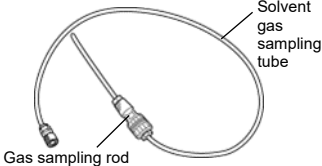
Part name		Remarks
	Protective cover	Part No.: 4777 4035 00
	Hand strap	Part No.: 0888 0605 90
	Tapered nozzle	Part No.: 4777 4057 20
	Belt clip	Part No.: 4777 9099 00
	Protective film	Part No.: 4777 4068 90
	BC-6000	Provided with lithium ion battery unit (BUL-6100) Part No.: BC-6000A(00)
	Adapter plug (Type C)	Provided with lithium ion battery unit (BUL-6100) on ATEX/IECEx model. Part No.: 2585 0064 30

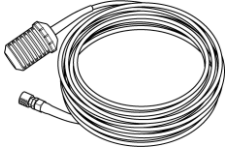
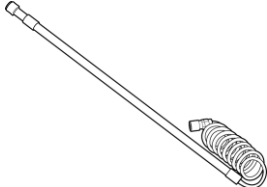
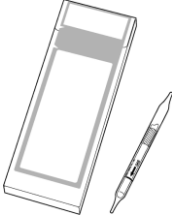
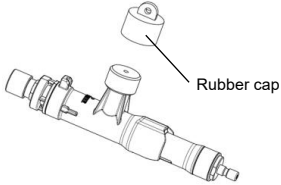
	AA alkaline battery (×3)	Provided with dry battery unit (BUD-6100) Part No. (single battery): 2753 3007 80
	CO ₂ removal filter CF-284	Provided when carbon dioxide sensor is installed Used for CO ₂ zero adjustment Part No.: 4383 0390 80
	Activated carbon filter CF-8350	Provided when VOC sensor is installed Used for fresh air adjustment Part No.: 4383 9299 50

3-1-3 Optional accessories

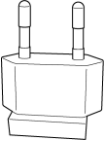
Part name	Remarks
	Dry battery unit (BUD-6100) Either the dry battery unit or lithium ion battery unit is provided, but additional units can be purchased if required. Part No.: 4777 39
	AA alkaline battery Used with the dry battery unit (BUD-6100) Part No. (single battery): 2753 3007 80
	Lithium ion battery unit (BUL-6100) Either the dry battery unit or lithium ion battery unit is provided, but additional units can be purchased if required. Part No.: 4777 38
 Solvent gas sampling tube Gas sampling rod	Gas sampling rod and gas sampling tube (for solvent gas) (75 cm/5 m/10 m/20 m/30 m) Part No.: 0904 0275 00 (Gas sampling rod) 0914 0135 30 (75 cm gas sampling tube) 0914 0136 10 (5 m gas sampling tube) 0914 0137 80 (10 m gas sampling tube) 0914 0138 50 (20 m gas sampling tube) 0914 0139 20 (30 m gas sampling tube)

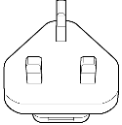
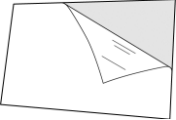
Part name		Remarks
	Sampling tube with float (for solvent gas) (5 m/10 m/20 m/30 m)	The waterproof filter inside the float separates water to allow gas detection. Part No.: 4777 9368 60 (5 m tube) Part No.: 4777 9374 60 (10 m tube) Part No.: 4777 9375 30 (20 m tube) Part No.: 4777 9376 10 (30 m tube)
	Two-stage gas sampling rod	The sampling rod length is as follows: Total length: Approx. 70 cm Contracted length: Approx. 40 cm Part No.: 4383 0730 80
	Pre-filter tube (CF-8338)	Used to selectively measure benzene with models with a VOC sensor (10.0 eV) installed. Set of 10. For more information, refer to the operating manual provided with the pre-filter tube. Part No.: 1879 2231 10
	Tube holder	Used to use the benzene filter tube Part No.: 0904 0284 10
	Lamp cleaning kit	For maintaining the VOC sensor Part No.: 9030 4017 20
	Pellet replacement tool	Used when using the lamp cleaning kit Part No.: 9030 4007 30

Part name		Remarks
	Adapter plug (Type C)	Part No.: 2585 0064 30
	Adapter plug (Type O)	Part No.: 2585 0066 80
	Adapter plug (Type BF)	Part No.: 2585 0065 10
	LCD protective film (set of 5)	Part No.: 4777 9064 60
	Data logger management program	Part No.: 9812 0050 80 (Japan Ex model) 9812 0060 70 (ATEX/IECEx model)



CAUTION

- If the separately sold gas sampling rod, gas sampling tube, sampling tube with float, or two-stage gas sampling rod is used when measuring highly adsorptive gas, the gas may be adsorbed, resulting in a lower concentration reading than the actual concentration of the detection target gas at the measurement point.

3-2 Part names and functions

3-2-1 Main unit

This section describes the main unit part names and functions with the battery unit removed. For more information on the battery unit, see '3-2-2 Battery unit'.

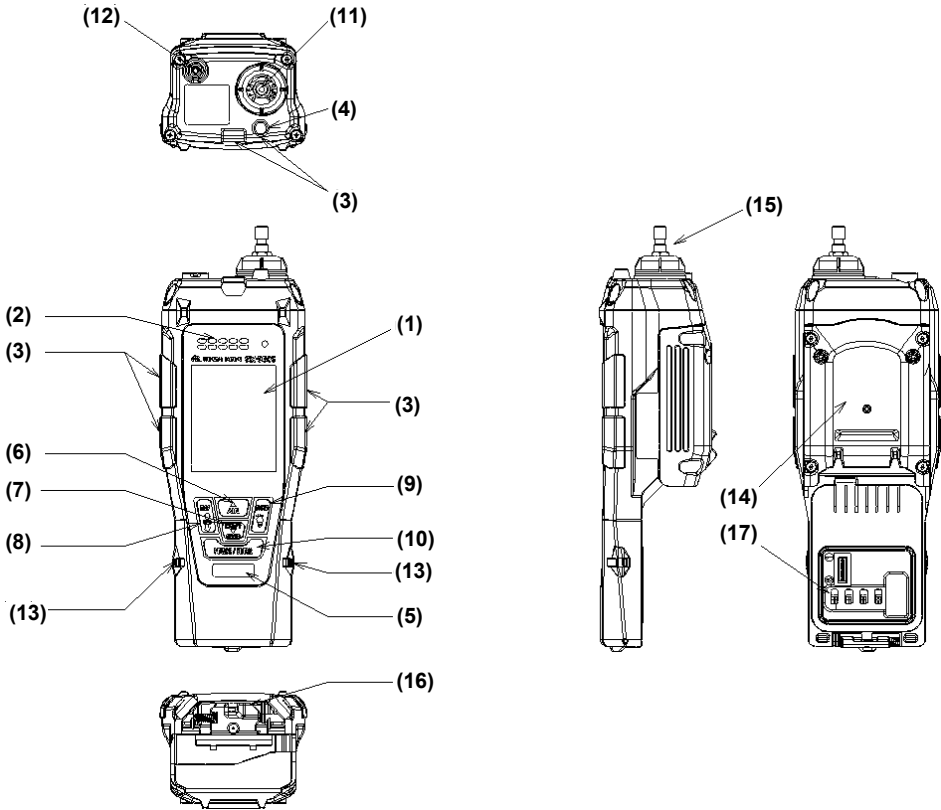

Name		Main function
(1)	LCD display	Displays the gas concentration and other information.
(2)	Buzzer sound opening	Emits operating and alarm sounds.
(3)	Alarm LED arrays	The LEDs flash in red when an alarm occurs.
(4)	Light	Lights up when the  (Light) button is held down.
(5)	Infrared communication port	Used for data communication with a PC when using the data logger management program (sold separately)

Name		Main function
(6)	▲/AIR button	Performs fresh air adjustment in measurement mode. Used to select items and adjust numerical values (up) in DISP mode and user mode
(7)	SHIFT/▼ /(PANIC) button	Used to select items and adjust numerical values (down) in DISP mode and user mode. Issues a panic alarm when held down.
(8)	DISP/LOCK button	Selects DISP mode. Selects display items in DISP mode. Hold down to lock the display when LCD inversion is set. (See '6-4-7 LCD inversion setting'.)
(9)	RESET  (Light) button	Resets the alarm when an alarm occurs. Hold down to turn on the light on the top.
(10)	POWER/ENTER button	Turns the power on and off. Used in DISP mode and user mode to confirm values or make settings
(11)	Gas inlet (GAS IN)	Draws in the gas.
(12)	Gas outlet (GAS OUT)	Discharges the gas drawn in.
(13)	Strap holes (two locations)	Used to attach the hand strap provided. There are two holes on each side (left and right).
(14)	Sensor cover	Protects the sensors inside. Do not open except for maintenance.
(15)	Filter case	Contains a dust filter. (Do not remove except for maintenance or when replacing the filter.)
(16)	Battery unit attachment/removal lever	Push while sliding to remove the battery unit.
(17)	Battery unit connection terminals	These terminals provide power from the battery unit to the product.



CAUTION

- Do not block the gas inlet. Doing so may prevent correct gas concentration measurement.
- Do not block the gas outlet or subject it to force. Doing so may cause the product to fail.
- Do not prod the buzzer sound opening with sharp objects. Doing so may result in ingress of water or foreign matter, resulting in malfunctions or damage to the product.
- Do not remove the panel sheet on the surface. Doing so will impair dustproof and waterproof performance.
- Do not block the buzzer sound opening with tape or other objects. This will prevent adjustment of the internal pressure of the product, which may result in malfunctions.
- Do not cover the infrared port with labels or other objects. This will prevent infrared communication.
- Before using the separately sold gas sampling rod and various gas sampling tubes, check to confirm that the tubes are free of damage and provide appropriate flow rates.
- Use of the separately sold gas sampling rod and various gas sampling tubes will create a response delay of up to three seconds per meter of flow length.

3-2-2 Battery unit

<Lithium ion battery unit (BUL-6100)>

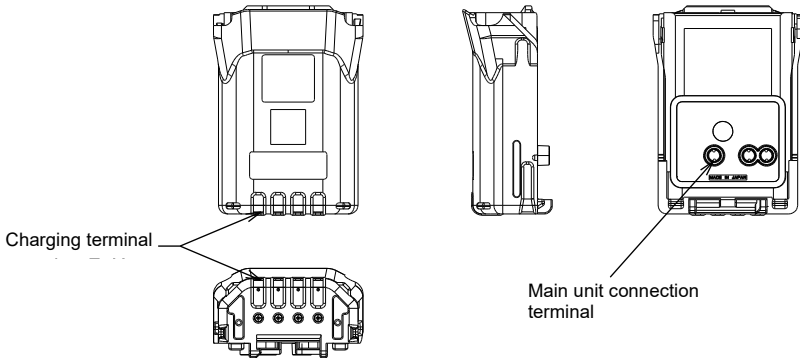

<Dry battery unit (BUD-6100)>

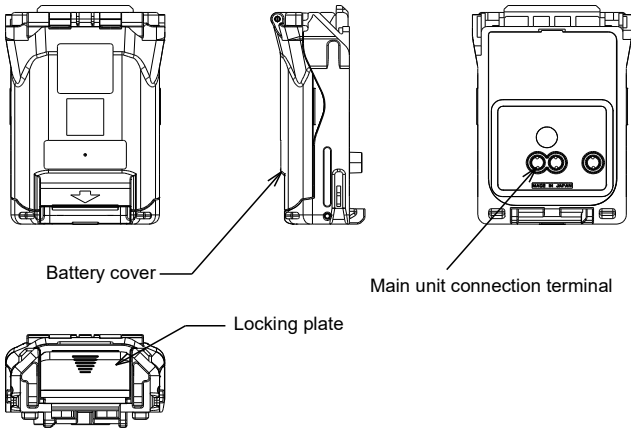

3-2-3 LCD display

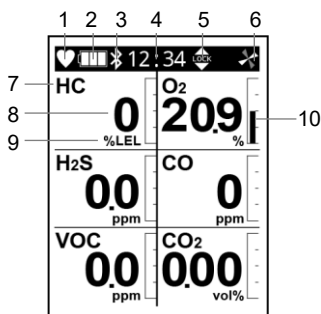

No.	Name	Main function
1	Operating status icon	Indicates the operating status in measurement mode. Blinks when normal.
2	Battery level icon	Indicates battery levels. See NOTE below for a guide to battery level indications.
3	Bluetooth icon	Displayed when the Bluetooth function is turned on
4	Clock display/ Gas alarm function off display	Displays the current time. Alternately displays the clock and [NO ALM] if the gas alarm function is disabled. (The default gas alarm function setting is enabled.) Alarms will not operate when the gas alarm function is disabled. (See '7-3-6 Disabling the gas alarm function'.)
5	Screen lock icon	Displayed when the LCD inversion setting is disabled. When this icon is displayed, the LCD display will not be inverted even when the product is held upside-down. (See '6-4-7 LCD inversion setting'.)
6	Flow confirmation icon	Indicates the gas suction status. The icon rotates when normal.
7	Gas name display	Displays the detection target gas name. The gas names displayed vary depending on the sensors installed.
8	Gas concentration display	Displays the detected gas concentration.
9	Units display	Displays units (ppm, ppb, vol%, %, %LEL) according to the sensor specifications.
10	Bar display	The (full scale) measurement range is segmented to indicate gas concentrations as bars. Indicates concentrations as ratios of the full scale.

NOTE

- ▶ Approximate battery levels are indicated as follows:

: Sufficient

: Low

: Needs charging (replace the batteries).

The battery level icon will blink if the battery level drops even further. The LED and buzzer operate every four seconds here.

- ▶ If a new ceramic type combustible gas sensor (NCR sensor) and thermal conductivity combustible gas sensor (TE sensor) are installed, gas concentrations are displayed for only one of the sensors depending on the detected concentrations. (See '6-4-1 Setting the combustible gas sensor range'.)

4

Alarm Functions

4-1 Gas alarm types

A gas alarm is triggered instantly if the concentration of the measured gas reaches or exceeds the alarm setpoints shown in the following tables. (Self-latching)

Gas alarm types include the first alarm (WARNING), second alarm (ALARM), TWA alarm, STEL alarm, OVER alarm (over scale), and M OVER alarm (negative sensor failure).

Gas alarms are prioritized as follows:

First alarm < second alarm < M OVER alarm < OVER alarm < TWA alarm < STEL alarm

4-2 Gas alarm setpoints

The default settings for gas alarm setpoints are as shown in the following tables:

<Combustible gas (New ceramic type sensor)>

Item	Detection target gas	Methane CH ₄		Isobutane HC (i-C ₄ H ₁₀)	
Sensor model		NCR-6309			
Explosion-proof specifications		Japan Ex	ATEX/IECEX	Japan Ex	ATEX/IECEX
Display range		0 – 100 %LEL	0 – 100 %LEL	0 – 100 %LEL	0 – 100 %LEL
Detection range		0 – 100 %LEL	0 – 100 %LEL	0 – 100 %LEL	0 – 100 %LEL
Resolution		1 %LEL	1 %LEL	1 %LEL	1 %LEL
Alarm setpoints	First alarm	10 %LEL	10 %LEL	10 %LEL	10 %LEL
	Second alarm	50 %LEL	25 %LEL	50 %LEL	25 %LEL
	Third alarm	50 %LEL	50 %LEL	50 %LEL	50 %LEL
	TWA	-	-	-	-
	STEL	-	-	-	-
	OVER	100 %LEL	100 %LEL	100 %LEL	100 %LEL
	M OVER	-10 %LEL	-10 %LEL	-10 %LEL	-10 %LEL

<Combustible gas (Thermal conductivity type sensor)>

Item	Detection target gas	Methane CH ₄
Sensor model		TE-7561
Explosion-proof specifications		Japan Ex and ATEX/IECEX
Display range		0 – 100 vol%
Detection range		0 – 100 vol%
Resolution		1 vol%
Alarm setpoints	First alarm	-
	Second alarm	-
	Third alarm	-
	TWA	-
	STEL	-
	OVER	100.0 vol%
	M OVER	-10.0 vol%

<Combustible gas (Non-dispersive infrared type sensor)>

Item	Detection target gas	Isobutane HC (i-C ₄ H ₁₀)	Methane CH ₄
Sensor model		DES-3311-2	DES-3311-3
Explosion-proof specifications		Japan Ex and ATEX/IECEX	Japan Ex and ATEX/IECEX
Display range		0 – 100.0 %LEL/ 100.0 %LEL – 30.0 vol%	0 – 100.0 %LEL/ 100.0 %LEL – 100.0 vol%
Detection range		0 – 100.0 %LEL	0 – 100.0 %LEL/ 100.0 %LEL – 100.0 vol%
Resolution		1 %LEL/0.5 vol%	1 %LEL/0.5 vol%
Alarm setpoints	First alarm	10 %LEL	10 %LEL
	Second alarm	50 %LEL	50 %LEL
	Third alarm	50 %LEL	50 %LEL
	TWA	-	-
	STEL	-	-
	OVER	30.0 vol%	100.0 vol%
	M OVER	-10 %LEL	-10 %LEL

<Combustible gas (Hot-wire semiconductor type sensor)>

Item	Detection target gas	Isobutane HC (i-C ₄ H ₁₀)	Methane CH ₄
Sensor model		SHS-8661	
Explosion-proof specifications		Japan Ex and ATEX/IECEX	Japan Ex and ATEX/IECEX
Display range		0 – 2,000 ppm	0 – 5,000 ppm
Detection range		0 – 500 ppm	0 – 2,000 ppm
Resolution		10 ppm	10 ppm
Alarm setpoints	First alarm	-	-
	Second alarm	-	-
	Third alarm	-	-
	TWA	-	-
	STEL	-	-
	OVER	2,000 ppm	5,000 ppm
	M OVER	-200 ppm	-500 ppm

<Carbon dioxide (Non-dispersive infrared type sensor)>

Item	Detection target gas	Carbon dioxide CO ₂	
Sensor model		DES-3311-1	DES-3311-4
Explosion-proof specifications		Japan Ex and ATEX/IECEX	Japan Ex and ATEX/IECEX
Display range		0 – 10.00 vol%	0 – 10,000 ppm
Detection range		0 – 5.00 vol%	0 – 10,000 ppm
Resolution		0.02 vol%	20 ppm
Alarm setpoints	First alarm	0.50 vol%	5,000 ppm
	Second alarm	3.00 vol%	OFF
	Third alarm	3.00 vol%	OFF
	TWA	0.50 vol%	5,000 ppm
	STEL	3.00 vol%	OFF
	OVER	10.00 vol%	10,000 ppm
	M OVER	-1.00 vol%	-1,000 ppm

<Oxygen (Electrochemical type sensor)>

Item	Detection target gas	Oxygen O ₂	
Sensor model		ESR-X13P	
Explosion-proof specifications		Japan Ex	ATEX/IECEX
Display range		0 – 40.0 %	0 – 40.0 %
Detection range		0 – 25.0 %	0 – 25.0 %
Resolution		0.1 %	0.1 %
Alarm setpoints	First alarm	19.5 %	19.5 %
	Second alarm	18.0 %	18.0 %
	Third alarm	25.0 %	23.5 %
	TWA	-	-
	STEL	-	-
	OVER	40.0 %	40.0 %
	M OVER	-1.0 %	-1.0 %

<Hydrogen sulfide/carbon monoxide (Electrochemical type sensor)>

Item	Detection target gas	Hydrogen sulfide H ₂ S		Carbon monoxide CO	
Sensor model		ESR-A1DP			
Explosion-proof specifications		Japan Ex	ATEX/IECEX	Japan Ex	ATEX/IECEX
Display range		0 – 200.0 ppm	0 – 200.0 ppm	0 – 2,000 ppm	0 – 2,000 ppm
Detection range		0 – 30.0 ppm	0 – 100.0 ppm	0 – 500 ppm	0 – 500 ppm
Resolution		0.1 ppm	0.1 ppm	1 ppm	1 ppm
Alarm setpoints	First alarm	1.0 ppm	5.0 ppm	25 ppm	25 ppm
	Second alarm	10.0 ppm	30.0 ppm	50 ppm	50 ppm
	Third alarm	10.0 ppm	100.0 ppm	50 ppm	1,200 ppm
	TWA	1.0 ppm	1.0 ppm	25 ppm	25 ppm
	STEL	5.0 ppm	5.0 ppm	200 ppm	200 ppm
	OVER	200.0 ppm	200.0 ppm	2,000 ppm	2,000 ppm
	M OVER	-3.0 ppm	-3.0 ppm	-50 ppm	-50 ppm

<Hydrogen sulfide (Electrochemical type sensor)>

Item	Detection target gas	Hydrogen sulfide H ₂ S	
Sensor model		ESR-A13i	
Explosion-proof specifications		Japan Ex	ATEX/IECEx
Display range		0 – 200.0 ppm	0 – 200.0 ppm
Detection range		0 – 30.0 ppm	0 – 100.0 ppm
Resolution		0.1 ppm	0.1 ppm
Alarm setpoints	First alarm	1.0 ppm	5.0 ppm
	Second alarm	10.0 ppm	30.0 ppm
	Third alarm	10.0 ppm	100.0 ppm
	TWA	1.0 ppm	1.0 ppm
	STEL	5.0 ppm	5.0 ppm
	OVER	200.0 ppm	200.0 ppm
	M OVER	-3.0 ppm	-3.0 ppm

<Carbon monoxide (Electrochemical type sensor)>

Item	Detection target gas	Carbon monoxide CO	
Sensor model		ESR-A13P / ESR-A1CP*	
Explosion-proof specifications		Japan Ex	ATEX/IECEx
Display range		0 – 2,000 ppm	0 – 2,000 ppm
Detection range		0 – 500 ppm	0 – 500 ppm
Resolution		1 ppm	1 ppm
Alarm setpoints	First alarm	25 ppm	25 ppm
	Second alarm	50 ppm	50 ppm
	Third alarm	50 ppm	1,200 ppm
	TWA	25 ppm	25 ppm
	STEL	200 ppm	200 ppm
	OVER	2,000 ppm	2,000 ppm
	M OVER	-50 ppm	-50 ppm

* The carbon monoxide sensor (ESR-A1CP) includes a correction function to reduce hydrogen interference. This function works for hydrogen concentrations up to 2,000 ppm. However, if used in environments exceeding 40 °C for more than 15 minutes, it may be affected by hydrogen interference and indicate a higher concentration than the actual carbon monoxide level.

<Toxic gas (Electrochemical type sensor)>

Item	Detection target gas	Sulfur dioxide SO ₂	Nitrogen dioxide NO ₂	Hydrogen cyanide HCN*
Sensor model		ESS-03DH	ESS-03DH	ESS-03DH
Explosion-proof specifications		Japan Ex and ATEX/IECEX	Japan Ex and ATEX/IECEX	Japan Ex and ATEX/IECEX
Display range		0 – 99.90 ppm	0 – 20.00 ppm	0 – 15.0 ppm
Detection range		0 – 99.90 ppm	0 – 20.00 ppm	0 – 15.0 ppm
Resolution		0.05 ppm	0.05 ppm	0.1 ppm
Alarm setpoints	First alarm	2.00 ppm	3.00 ppm	5.0 ppm
	Second alarm	5.00 ppm	6.00 ppm	10.0 ppm
	Third alarm	5.00 ppm	6.00 ppm	10.0 ppm
	TWA	2.00 ppm	3.00 ppm	OFF
	STEL	5.00 ppm	OFF	4.7 ppm
	OVER	99.90 ppm	20.00 ppm	15.0 ppm
	M OVER	-10.00 ppm	-2.00 ppm	-1.5 ppm

* Due to export restrictions, hydrogen cyanide sensors indicate concentrations of 0.0 – 0.2 ppm as 0.0 ppm for both Japan Ex and ATEX/IECEX models.

Item	Detection target gas	Ammonia NH ₃	Chlorine Cl ₂	Phosphine PH ₃
Sensor model		ESS-B332	ESS-B335	ESS-03DH
Explosion-proof specifications		Japan Ex and ATEX/IECEX	Japan Ex and ATEX/IECEX	Japan Ex and ATEX/IECEX
Display range		0 – 400.0 ppm	0 – 10.00 ppm	0 – 20.00 ppm
Detection range		0 – 400.0 ppm	0 – 10.00 ppm	0 – 1.00 ppm
Resolution		0.5 ppm	0.05 ppm	0.01 ppm
Alarm setpoints	First alarm	25.0 ppm	0.50 ppm	0.30 ppm
	Second alarm	50.0 ppm	1.00 ppm	1.00 ppm
	Third alarm	50.0 ppm	1.00 ppm	1.00 ppm
	TWA	25.0 ppm	0.50 ppm	0.30 ppm
	STEL	35.0 ppm	1.00 ppm	1.00 ppm
	OVER	400.0 ppm	10.00 ppm	20.00 ppm
	M OVER	-40.0 ppm	-1.00 ppm	-2.00 ppm

<Volatile organic compounds (Photoionization type (PID) sensor)>

Item	Detection target gas	Volatile organic compounds VOCs	Volatile organic compounds VOCs	Volatile organic compounds VOCs
Sensor model		PIS-001A	PIS-002A	PIS-003
Photoionization energy		10.6 eV	10.6 eV	10.0 eV
Explosion-proof specifications		Japan Ex and ATEX/IECEX	Japan Ex and ATEX/IECEX	Japan Ex and ATEX/IECEX
Display range		0 – 40,000 ppb	0 – 4,000 ppm	VOC: 0 – 100.0 ppm Benzene: 0 – 50.0 ppm*
Detection range		0 – 40,000 ppb	0 – 4,000 ppm	VOC: 0 – 100.0 ppm Benzene: 0 – 50.0 ppm*
Resolution		1 ppb (0 – 4,000 ppb) 10 ppb (4,000 – 40,000 ppb)	0.1 ppm (0 – 400.0 ppm) 1 ppm (400 – 4,000 ppm)	0.01 ppm (0 – 10.00 ppm) 0.1 ppm (10.0 – 100.0 ppm)
Alarm setpoints	First alarm	5,000 ppb	400.0 ppm	5.00 ppm
	Second alarm	10,000 ppb	1,000 ppm	10.00 ppm
	Third alarm	10,000 ppb	1,000 ppm	10.00 ppm
	TWA	OFF	OFF	OFF
	STEL	OFF	OFF	OFF
	OVER	40,000 ppb	4,000 ppm	100.0 ppm
	M OVER	-5,000 ppb	-400.0 ppm	-10.0 ppm

* Display range and detection range for the benzene select mode

NOTE

- ▶ The alarm setpoints (including “OFF”) indicated for the first alarm (WARNING), second alarm (ALARM), TWA alarm, and STEL alarm in the tables above can be changed. However, the setpoint cannot be changed for those shown as “-”. (See ‘7-3-1 Setting alarm setpoints’.)
- ▶ The M OVER alarm (negative sensor failure) occurs when the zero point drifts to the negative side.
- ▶ Gas concentrations are checked at one-second intervals to determine whether to issue an alarm.

4-3 Gas alarm patterns

<Gas alarm buzzer sounding and lamp flashing patterns>

If a gas alarm occurs, the user is notified by the buzzer sounding and the alarm LED array flashing. The behavior differs depending on the type of alarm.

Alarm type	First alarm	Second alarm	Third alarm
Buzzer sounding	Repeated alternating strong and weak beeps at about 1-second intervals "Beep, beep"	Repeated alternating strong and weak beeps at about 0.5-second intervals "Beep, beep, beep, beep"	Repeated alternating strong and weak beeps at about 0.5-second intervals "Beep, beep, beep, beep"
Alarm LED array flashing	Repeated flashing at about 1-second intervals	Repeated flashing at about 0.5-second intervals	Repeated flashing at about 0.5-second intervals
Vibration	Vibration when alarm occurs		

Alarm type	TWA alarm	STEL alarm	OVER alarm	M OVER alarm
Buzzer sounding	Repeated alternating strong and weak beeps at about 1-second intervals "Beep, beep"	Repeated alternating strong and weak beeps at about 1-second intervals "Beep, beep"	Repeated alternating strong and weak beeps at about 0.5-second intervals "Beep, beep, beep, beep"	Repeated intermittent beeps at about 1-second intervals "Beep, beep"
Alarm LED array flashing	Repeated flashing at about 1-second intervals	Repeated flashing at about 1-second intervals	Repeated flashing at about 0.5-second intervals	Repeated flashing at about 1-second intervals
Vibration	Vibration when alarm occurs			

<Alarm pattern (H-HH-HHH)>

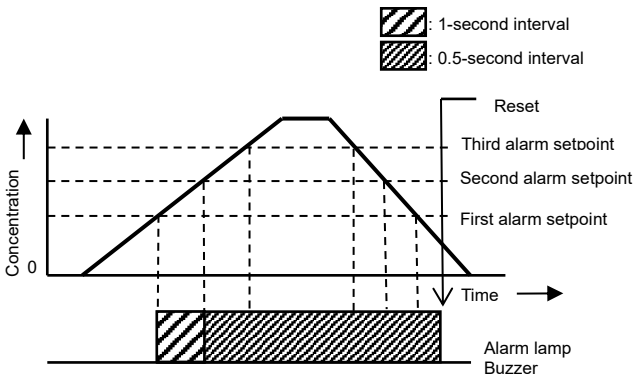

<Alarm pattern (L-LL-H)>

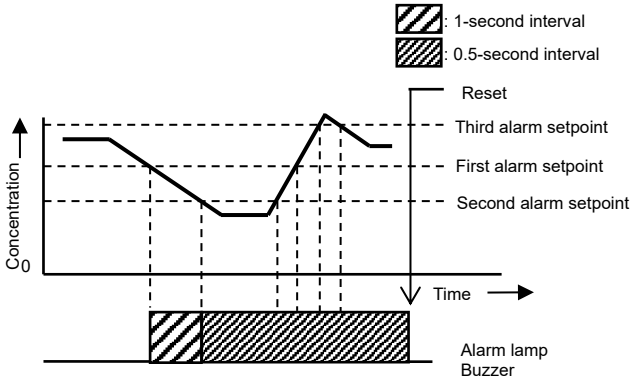

<Gas alarm display>

When a gas alarm occurs, the alarm type is indicated in the units display area of the LCD, and the corresponding gas concentration display blinks.

If the measurement range is exceeded (over scale), [OVER] appears alternately in the units display area, and [OVER] blinks in the gas concentration display area.

<Display example ([CH4]: First alarm triggered)>

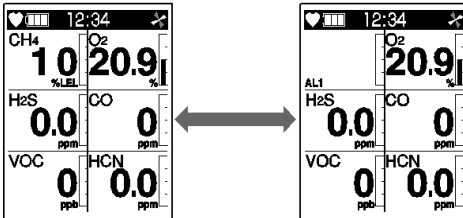

Alarm type	First alarm	Second alarm	Third alarm	TWA alarm	STEL alarm	OVER alarm	M OVER alarm
Units display area indication	[AL1]	[AL2]	[AL3]	[TWA]	[STEL]	[OVER]	[M OVER]
Gas concentration display area indication	Gas concentration and [AL1] displayed alternately	Gas concentration and [AL2] displayed alternately	Gas concentration and [AL3] displayed alternately	Gas concentration and [TWA] displayed alternately	Gas concentration and [STEL] displayed alternately	Blinking [OVER]	Blinking [MOVER]



WARNING

- A gas alarm indicates the presence of extreme danger. The user must take appropriate action after taking appropriate steps to ensure safety.

NOTE

- ▶ The alarm pattern can be checked by performing an alarm test at the alarm setpoint display in display mode. Note, however, that the gas concentration display will not blink in alarm tests. (See '8-4 Performing alarm tests'.)
 - ▶ If self-latching is selected, the alarm is reset when the RESET button is pressed after the gas concentration has returned to normal.
If auto-reset is selected, the alarm is reset automatically once the gas concentration has returned to normal.
-

4-4 Fault alarm

A fault alarm is triggered if an abnormality is detected in the product. (Self-latching)

Fault alarm types include system, battery voltage, clock, sensor, and flow rate abnormalities.

If a fault alarm occurs, the user is notified by the buzzer sounding and alarm LED array flashing.

- Buzzer sounding: Repeated intermittent beeps at about 1-second intervals (“Beep-beep, beep-beep”)
- Alarm LED array flashing: Repeated flashing at about 1-second intervals

The following shows fault alarm display examples:

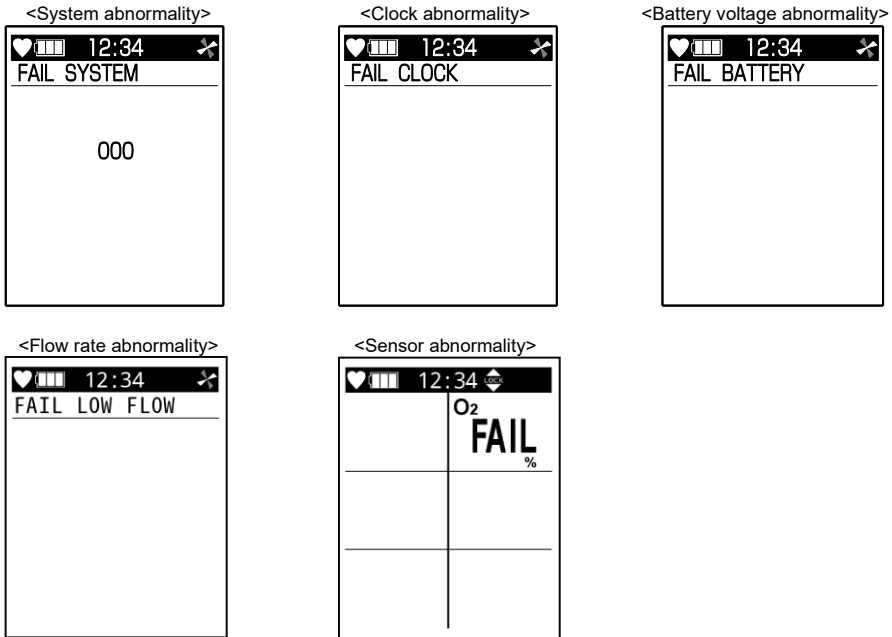

CAUTION

- If a fault alarm occurs, determine the cause and take appropriate action.
If the problem lies with the product and the fault occurs repeatedly, contact RIKEN KEIKI immediately.

NOTE

- ▶ For more information on malfunctions (error messages), see ‘10 Troubleshooting’.
- ▶ Press the RESET button to reset the alarm.

4-5 Man down alarm

A man down alarm is triggered if the built-in motion sensor, which monitors the motion of the user carrying the product, detects no user motion for a certain period of time.



WARNING

- The man down alarm is intended to assist those in the vicinity of the user to make appropriate decisions. The detection results are not intended to assure life or safety. Do not rely solely on this function when using the product.

<Man down alarm buzzer sounding and lamp flashing patterns>

Alarm type	Prealarm 1	Prealarm 2	Main alarm
Buzzer sounding	Repeated intermittent beeps at about 1-second intervals "Blip, blip"	Repeated intermittent beeps at about 0.5-second intervals "Blip, blip, blip, blip"	Repeated alternating strong and weak beeps at about 1-second intervals "Beep, beep, beep, beep"
Alarm LED array flashing	Repeated flashing at about 1-second intervals	Repeated flashing at about 0.5-second intervals	Repeated flashing at about 1-second intervals

<Man down alarm display and alarm patterns>

If abnormal user motion is detected, the LEDs flash and alarms are triggered while vibrating in the following sequence: prealarm 1, prealarm 2, and main alarm.

If the main alarm is triggered, [MN.DWN] is displayed in the LCD clock display area.

The times for triggering the prealarms and main alarm are as follows:

- Prealarm 1: 60 seconds after detection
- Prealarm 2: 75 seconds after detection
- Main alarm: 90 seconds after detection

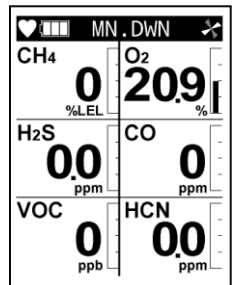

NOTE

- ▶ By default, the man down alarm setting is disabled. To use the man down alarm, set it to [ON] in user mode. (See '7-4-1 Enabling/disabling the man down alarm'.)
- ▶ The man down prealarms are stopped and measurement mode is resumed if user motion is detected.
- ▶ To stop the man down main alarm, press the RESET button.

4-6 Panic alarm

The panic alarm is a function that allows the user to trigger an alarm manually. Hold down the SHIFT/▼ (PANIC) button for approximately one second to trigger the alarm.

<Panic alarm buzzer sounding and lamp flashing patterns>

Alarm type	Prealarm	Main alarm
Buzzer sounding	Repeated intermittent beeps at about 0.5-second intervals “Blip, blip, blip, blip”	Repeated alternating strong and weak beeps at about 0.5-second intervals “Beep, beep, beep, beep”
Alarm LED array flashing	Repeated flashing at about 0.5-second intervals	Repeated flashing at about 0.5-second intervals

<Panic alarm display and alarm pattern>

Holding down the SHIFT/▼ (PANIC) button for approximately one second causes the LEDs to flash and triggers the prealarm followed by the main alarm while vibrating.

If the main alarm is triggered, [PANIC] is displayed in the LCD clock display area.

The times for triggering the prealarm and main alarm are as follows:

- Prealarm: Triggered approximately one second after holding down the SHIFT/▼ (PANIC) button (lasts for approximately four seconds)
- Main alarm: Triggered approximately five seconds after holding down the SHIFT/▼ (PANIC) button

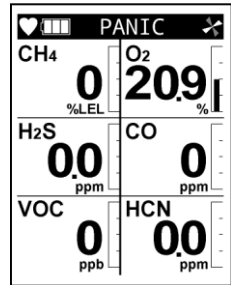

NOTE

- ▶ By default, the panic alarm setting is disabled. To use the panic alarm, set it to [ON] in user mode. (See '7-5-1 Enabling/disabling CO₂ fresh air adjustment'.)
- ▶ To stop the panic alarm, press the RESET button.

5

Usage Instructions

5-1 Usage note

Observe all usage precautions when using the product.

Ignoring these precautions may damage the product and prevent inaccurate gas concentration measurement.

Check the following before starting gas concentration measurement:

- Product model and specifications
- Gas alarm setpoints
- The protective film attached to the LCD to protect it against scratching during shipping has been removed.
- The tapered nozzle is not bent or damaged.
- The tapered nozzle is correctly connected.
- The filter inside the filter case is not contaminated or clogged.
- The battery level is sufficient.
- The pump is operating normally. (Check that a low flow rate alarm occurs when the gas inlet is blocked with a finger.)



WARNING

- Protective film is attached to the product LCD to protect it against scratching during shipping. Be sure to peel off this protective film before using the product. Explosion-proofing cannot be guaranteed if the protective film is left attached.

NOTE

- ▶ If the settings for the product have been altered from an external device, be sure to confirm that the settings have been altered correctly.
 - ▶ For more information on the product specifications, see '11-1 Main unit specifications' and '11-2 Sensor specifications'.
 - ▶ For information on the product gas alarm setpoint default settings, see '4-2 Gas alarm setpoints'.
 - ▶ For information on the low flow rate alarm and how to reset it, see '4-4 Fault alarm'.
-

5-2 Removing and attaching the battery unit and charging

5-2-1 Removing and attaching the battery unit

Follow the procedure described below to remove and attach the lithium ion battery unit (BUL-6100) or dry battery unit (BUD-6100).



DANGER

- The battery unit must be removed and attached only in a safe place.



CAUTION

- Be sure to turn off the power for the product before removing or attaching the battery unit.
- When attaching the battery unit, use the battery unit attachment/removal lever to lock it into place. If the battery unit is not correctly secured in place, it may fall off or water may get in through the gaps, causing the product to fail.
- When attaching the battery unit, check to confirm that nothing is trapped between the battery unit and the main unit. If minute foreign matter is trapped beneath the battery unit and the main unit, water may get in, causing failure.
- Do not short-circuit the connection terminals with metal objects. The battery will overheat or the battery level will drop sharply.
- Avoid damaging the rubber seal. To maintain dustproof and waterproof performance, we recommend replacing the rubber seal every two years, regardless of condition.

- 1 **Confirm that the power for the main unit is turned off.**

If the power is on, press the POWER/ENTER button to turn it off.

- 2 **Push in and slide the battery unit attachment/removal lever on the underside of the battery unit to the right while applying pressure.**

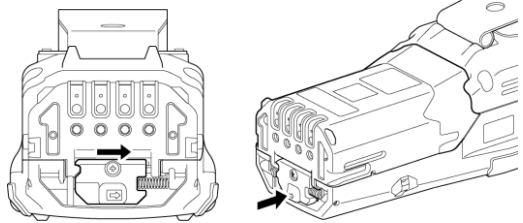

- 3 **Remove the battery unit from the main unit.**

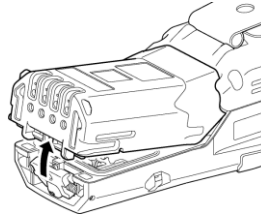

- 4 **Attach a new battery unit.**

- 5 **Push in the battery unit attachment/removal lever in the same way as in Step 2 and hook the lever into the groove on the underside of the battery unit.**

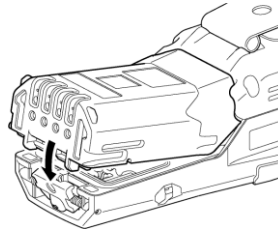

5-2-2 Charging the lithium ion battery unit (BUL-6100)

The product can be used with a lithium ion battery unit (BUL-6100).

When using the product for the first time or if the battery level is low, charge the battery unit before use.



DANGER

- Charge the lithium ion battery unit only in a safe place.
- Be sure to use the dedicated charger for charging.
- Charge the battery unit at an ambient temperature between 0 °C and +40 °C.



CAUTION

- Do not use the product while charging the battery unit. Doing so will prevent correct measurement. This will also hasten battery degradation and reduce battery life.
- The AC adapter is neither waterproof nor dustproof. Do not charge the battery while the main unit is wet.
- The AC adapter is not explosion-proof.
- Always unplug the AC adapter from the power outlet when not in use.

NOTE

- ▶ The lithium ion battery unit may get hot during charging. This is not an abnormality.
- ▶ Wait at least 10 minutes before use. The main unit will be hot immediately after charging. Using the lithium ion battery unit while it is still hot may prevent correct measurement.
- ▶ The battery unit cannot be charged when fully charged.
- ▶ The lithium ion battery unit can also be charged while removed from the product.

- 1 Plug the DC plug on the AC adapter into the charger DC jack.**

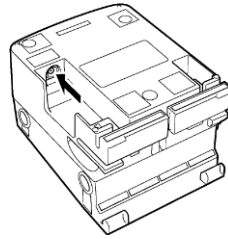

- 2 Plug the AC adapter into the power outlet.**

- 3 Insert the product straight down into the charger.**
The charging indicator LED on the charger lights up in red when the main unit is inserted into the charger. (Full charge requires approximately six hours at maximum.) Once charging is complete, the charging indicator LED goes out.

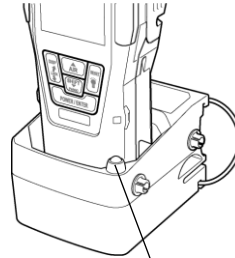

Charging indicator LED

- 4 When charging is complete, unplug the AC adapter from the power outlet.**

5-2-3 Replacing batteries in the dry battery unit (BUD-6100)

The product can be used with a dry battery unit (BUD-6100).

When using the product for the first time or if the battery level is low, replace the batteries with three new alkaline AA batteries.



DANGER

- The product explosion-proof standards include the use of the specified dry batteries. When using as an explosion-proof product, use three specified alkaline AA batteries.
- Be sure to use only the specified batteries.
- Be sure to replace the batteries only in a safe place.



CAUTION

Battery replacement

- Be sure to turn off the power for the product before replacing the batteries.
- Note the polarity when inserting new batteries.
- After closing the battery cover, secure the battery cover in place with the locking plate. If the battery cover is not properly secured, the batteries may fall out or water may get in through gaps. Water may also get in if minute foreign matter is trapped between the cover and the main unit.

Batteries

- When replacing the batteries, replace all three with new batteries at the same time.
- Do not use rechargeable batteries.

1 Release the locking plate on the dry battery unit battery cover.

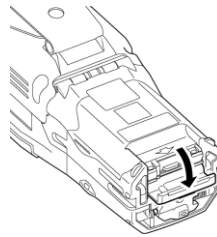

2 Open the battery cover.

3 Insert three new AA alkaline batteries.

Remove any old batteries inside.
Note the polarity when inserting new batteries.

- 4 **Close the battery cover, then close the locking plate.**
Close the locking plate firmly until it clicks into place.

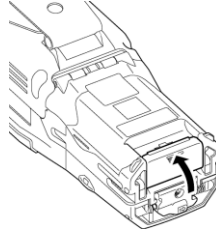

5-3 Attaching the tapered nozzle

Attach the provided tapered nozzle to the product gas inlet to perform measurements.

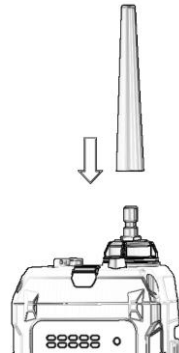

DANGER

- Do not attach a tapered nozzle or any other parts that are not specified by RIKEN KEIKI.

5-4 Turning on the power

When the power is turned on, various settings including the date and time and alarm setpoints are displayed, and then the normal mode concentration display screen is displayed.

If an SHS sensor is installed, a screen first appears to confirm whether to proceed to normal mode or leak check mode.

NOTE

- ▶ When the power is turned on, the LCD, LEDs, and buzzer operate. Before using the product, check that these operate correctly.

1 Hold down the POWER/ENTER button (for approximately three seconds) until the buzzer blips once.

When the power is turned on, the LCD fully lights up and changes automatically as shown below before displaying the normal measurement mode measurement screen. (Approx. 50 seconds)

If an SHS sensor is installed, you must select a mode in [MODE SELECT].

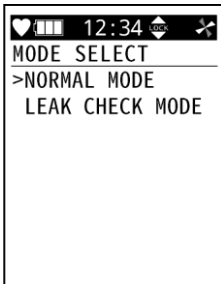

Mode selection
(Displayed only if an SHS sensor is installed)

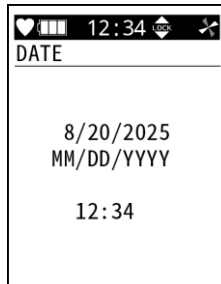

Date and time display

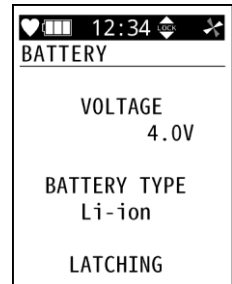

Battery voltage display

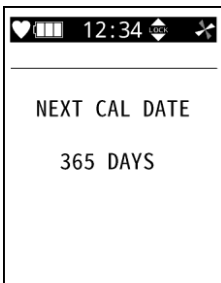

Maintenance notification display

* Japan Ex model:
Maintenance notification display
ATEX/IECEX model:
Adjustment expiration display

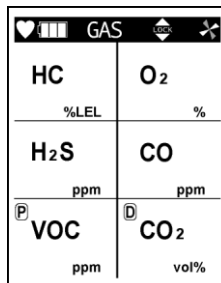

Detection target gas names

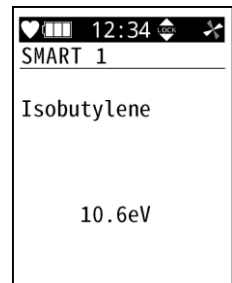

VOC gas name / Sensor type display
(Displayed only if a VOC sensor is installed)

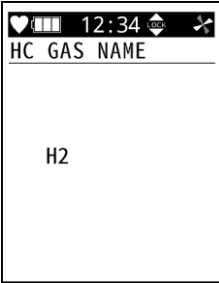

Combustible gas conversion gas name display
(Displayed only when set)

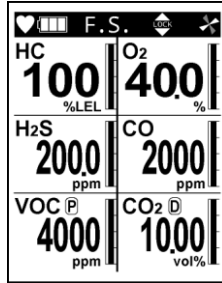

Full scale display

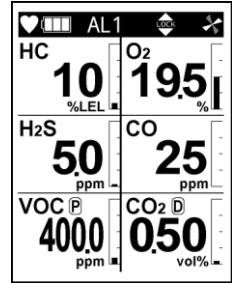

First alarm setpoint display

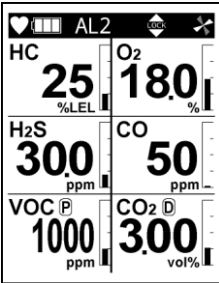

Second alarm setpoint display

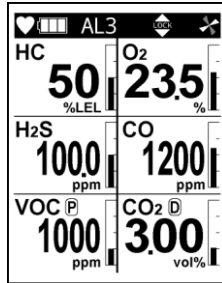

Third alarm setpoint display

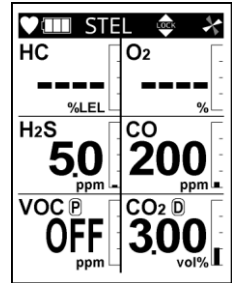

STEL alarm setpoint display

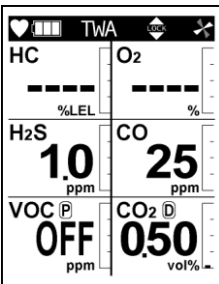

TWA alarm setpoint display

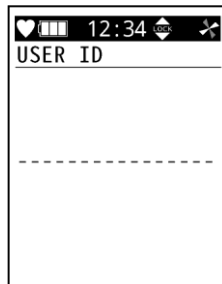

User ID display

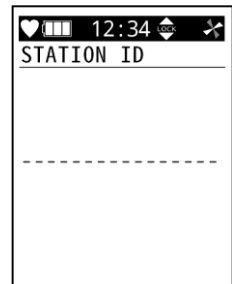

Station ID display

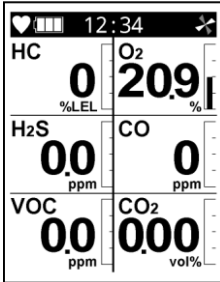

The buzzer blips twice and the normal measurement mode measurement screen is displayed.



CAUTION

- Turn on the power for the product in clean air.
- Fresh air adjustment must be performed before measuring gas concentrations after turning on the power. (See '5-6 Performing fresh air adjustment'.)
- On models that detect combustible gases, the message [READ GAS LIST IN MANUAL] may be displayed on a screen displayed after turning on the power with the buzzer sounding and lamp flashing. If this screen appears, press the RESET button to reset the alarm.
- The above screen appears when the combustible gas sensor is placed under the poisoning effects of silicone compounds or halides. If the above screen is displayed, the conversion function can be used only for those gas types marked "Y" in the "Is conversion possible when restricted?" column. (See '6-4-2 Combustible gas conversion gas selection'.) To continue to use the conversion function for gas types marked "N", contact RIKEN KEIKI.

NOTE

- ▶ If an abnormality is detected in the R sensor PCB, R sensor, or smart sensor, [FAIL] will appear, and a sensor abnormality alarm is triggered. If an alarm occurs, press the RESET button to temporarily reset the sensor abnormality alarm. However, the alarm cannot be reset if there is an abnormality in all of the sensors. After the alarm is reset, [- - -] appears in the concentration display area of the gas for which the sensor abnormality occurred, and measurement is not possible for that particular gas. Contact RIKEN KEIKI immediately.
- ▶ If an abnormality arises in the internal clock, a fault alarm [FAIL CLOCK] may be triggered. If a fault alarm occurs, press the RESET button to temporarily reset the fault alarm. Measurement will start with the incorrect clock time and date. Contact RIKEN KEIKI for maintenance and repairs.
- ▶ In modes other than concentration display screen and display mode, the LEDs flash every four seconds.

Mode selection

- ▶ Displayed only if an SHS sensor is installed (See '1-2 Intended use' and '1-3 Checking the detection target gases and product specifications'.)
- ▶ Normal mode will be selected automatically if no SHS sensor is installed.
- ▶ Normal mode refers to the mode for detecting target gases using sensors other than SHS sensors.
- ▶ Leak check mode is the mode for detecting target gases (combustible gas [ppm]) using SHS sensors. (See '5-5-2 Leak check mode (SHS sensor only)'.)
- ▶ If no button is pressed for approximately 20 seconds on the mode selection screen, the product automatically switches to normal mode.

Date and time display

- ▶ Displays the current date and time.

Battery voltage display

- ▶ Displays the type of battery installed and alarm type.

Maintenance notification display (Japan Ex model)

- ▶ With the Japan Ex model, the number of days remaining until one year (365 days) is displayed after the power is first turned on or after the last gas adjustment date. The buzzer sounds and [MAINT. DATE PAST] is displayed on the LCD to notify that more than one year has elapsed since the power was first turned on or the last adjustment date. Press the RESET button to proceed to the next screen.

Adjustment expiration display (ATEX/IECEx model)

- ▶ When the adjustment notification expiration display setting is enabled with the ATEX/IECEx model (enabled by default), the adjustment expiration and number of days remaining until the adjustment expiration are displayed. If the set adjustment expiration date has passed, notification of expiration is given.

The behavior varies depending on the adjustment expiration function settings. The default setting is "Confirm".

- Confirm: Triggers a fault alarm. Press the RESET button to proceed to the next screen. Pressing the POWER/ENTER button selects user mode gas adjustment.
- Do not confirm: The next screen is automatically displayed after six seconds. Pressing the POWER/ENTER button selects user mode gas adjustment.
- Disable: Triggers a fault alarm. User mode gas adjustment is automatically selected after six seconds.

Bump test expiration display

- ▶ When the bump test expiration function is enabled (disabled by default), the bump test expiration and number of days remaining until bump test expiration are displayed. If the set bump test expiration date has passed, notification of expiration is given.

The behavior varies depending on the bump test expiration function settings. The default setting is "Confirm".

- Confirm: Triggers a fault alarm. Press the RESET button to proceed to the next screen. Pressing the POWER/ENTER button selects user mode gas adjustment.
- Do not confirm: The next screen is automatically displayed after six seconds. Pressing the POWER/ENTER button selects user mode gas adjustment.
- Disable: Triggers a fault alarm. User mode gas adjustment is automatically selected after six seconds.

Detection target gas names [GAS]

- ▶ Displays the detection target gas names. If a PIS sensor, ESS sensor, DES sensor, or SHS sensor is installed, the detection principle is indicated by the following codes, respectively.

Code	Detection target gas		Detection principle
Ⓟ	Volatile organic compounds (VOCs)		Photoionization type (PID)
Ⓔ	Sulfur dioxide (SO ₂) Nitrogen dioxide (NO ₂) Hydrogen cyanide (HCN)	Ammonia (NH ₃) Chlorine (Cl ₂) Phosphine (PH ₃)	Electrochemical type
Ⓓ	Carbon dioxide (CO ₂) <vol%> Carbon dioxide (CO ₂) <ppm> Combustible gas (HC) <%LEL / vol%> Combustible gas (CH ₄) <%LEL / vol%>		Infrared type
Ⓢ	Combustible gas (HC) <ppm> Combustible gas (CH ₄) <ppm>		Hot-wire semiconductor type

VOC gas name / Sensor type display [GAS SMART 1 / GAS SMART 2]

- ▶ If a VOC sensor is installed, [Isobutylene] or the conversion gas name (if set) is displayed. The sensor type (10.6 eV/10.0 eV) is displayed in the second row.

Combustible gas conversion gas name display

- ▶ Displays the conversion gas name if gas conversion is set with a new ceramic type combustible gas sensor (NCR sensor).

Full scale display

- ▶ Displays the full-scale value of the detection target gas.

First alarm setpoint display

- ▶ Displays the first alarm setpoint for the detection target gas.

Second alarm setpoint display

- ▶ Displays the second alarm setpoint for the detection target gas.

Third alarm setpoint display

- ▶ Displays the third alarm setpoint for the detection target gas.

STEL alarm setpoint display

- ▶ Displays the STEL alarm setpoint for the detection target gas. [OFF] is displayed when the STEL alarm setpoint is disabled. [----] is displayed when the STEL alarm setpoint is invalid.
- ▶ The STEL value is the time-weighted average exposure over a short duration (15 minutes). It is generally accepted that almost all users will not experience adverse health effect if the STEL value does not exceed this value. When both STEL and TWA values are subject to restrictions, both values must be controlled below the specified limits.
- ▶ The STEL value refers to the sum of 15 pieces of average value data for measured values over a period of 60 seconds divided by 15. The value is refreshed every 60 seconds.

TWA alarm setpoint display

- ▶ Displays the TWA alarm setpoint for the detection target gas. [OFF] is displayed when the TWA alarm setpoint is disabled. [----] is displayed when the TWA alarm setpoint is invalid.
- ▶ The TWA value refers to the time-weighted average concentration limit of a toxic substance for a normal 8-hour workday and a 40-hour workweek to which almost all users may be repeatedly exposed without adverse health effect.
- ▶ The TWA value refers to the value obtained by integrating average value data for measured values over a period of 60 seconds and then dividing the integrated value for a period of 8 hours by 480. The value is refreshed every 60 seconds.

User ID display

- ▶ Displays the selected user ID, if set.

Station ID display

- ▶ Displays the selected station ID, if set.

Automatic fresh air adjustment confirmation display

- ▶ If the automatic fresh air adjustment function is enabled, a screen is displayed to confirm whether or not to perform fresh air adjustment before switching to the normal mode concentration display screen. Pressing the POWER/ENTER button performs fresh air adjustment (the default setting is disabled). To skip fresh air adjustment, press the DISP button. The product switches to the concentration display screen when automatic fresh air adjustment ends. For more information on fresh air adjustment, see '5-6 Performing fresh air adjustment'.



5-5 Detection modes

The product features three different detection modes (normal mode, leak check mode, and benzene select mode) depending on the sensors installed. Leak check mode is displayed only if an SHS sensor is installed, and benzene select mode is displayed only if a VOC sensor (10.0 eV) is installed.

5-5-1 Normal mode

Normal mode refers to the mode for detecting target gases using sensors other than SHS sensors. If no SHS sensor is installed, normal mode is selected automatically when the power is turned on. If an SHS sensor is installed, a screen is displayed when the power is turned on to select whether to proceed to normal mode or leak check mode. (See '5-4 Turning on the power'.)

NOTE

- ▶ If no button is pressed for approximately 20 seconds on the mode selection screen, the product automatically switches to normal mode.
-

<Normal mode basic operation flow>

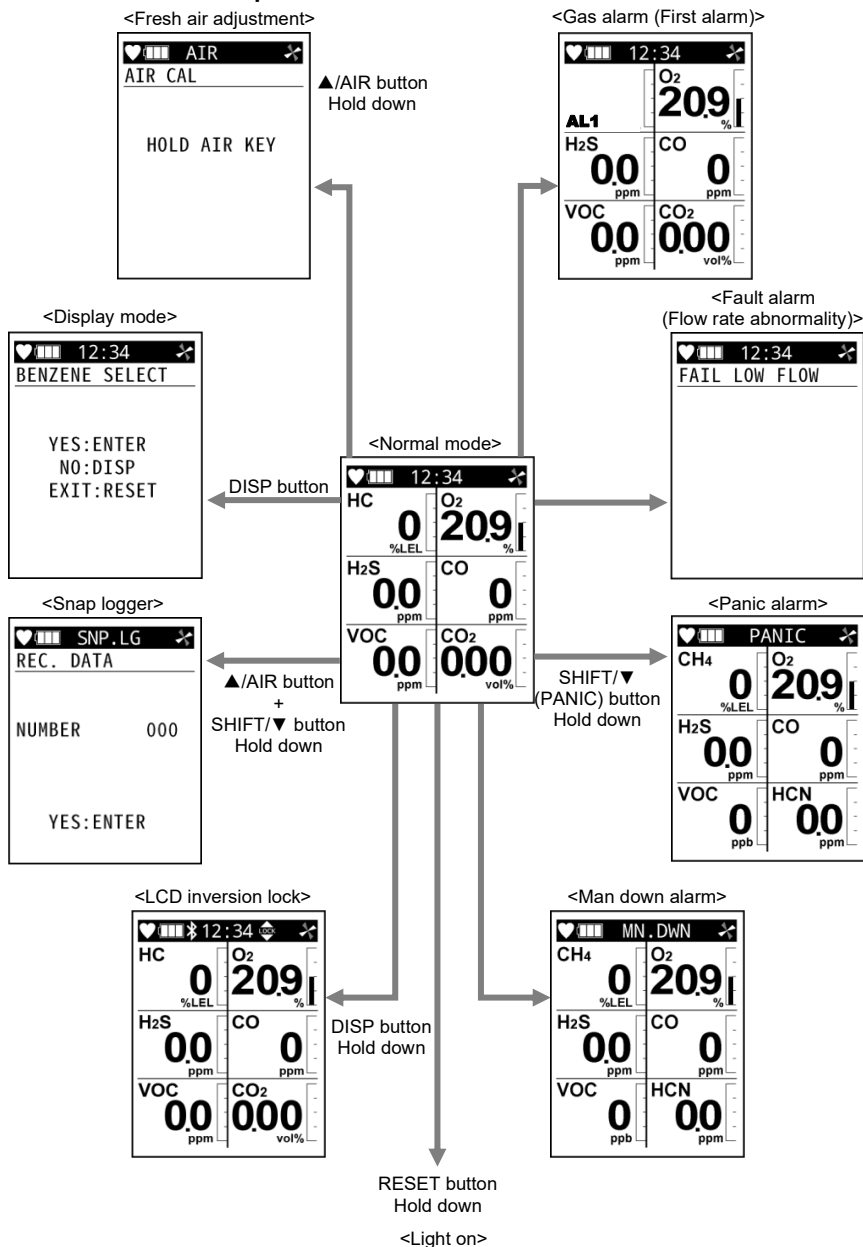

5-5-2 Leak check mode (SHS sensor only)

Leak check mode is the mode for detecting target gas (combustible gas [ppm]) leaks using a hot-wire semiconductor type sensor (SHS sensor). Leak check mode allows detection using a full scale of 500 ppm, 1,000 ppm, 2,000 ppm, or 5,000 ppm.

<Leak check mode basic operation flow>

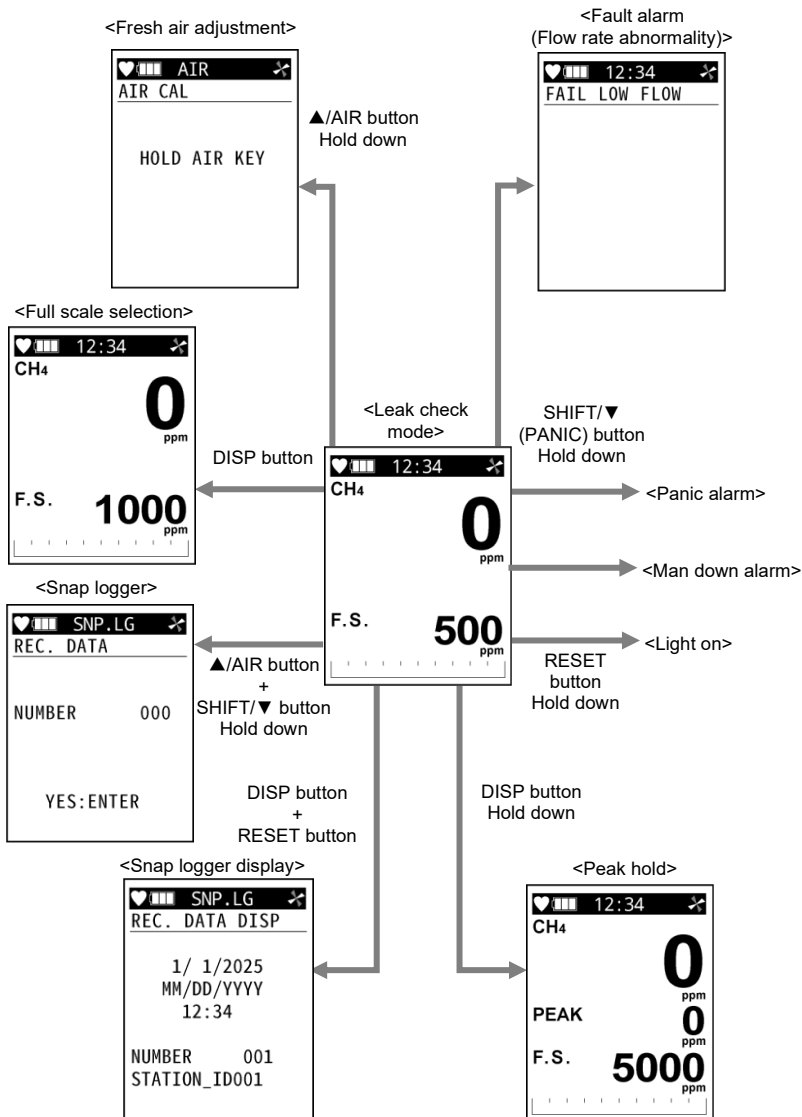

NOTE

- ▶ When a thermal conductivity type sensor (TE sensor) or new ceramic type sensor (NCR sensor) is installed with the same detection target gas as the hot-wire semiconductor type sensor (SHS sensor), the range will automatically switch to suit the detected gas concentration.

<Leak check mode operation>

In leak check mode, the bars displayed increase or decrease and the buzzer sounds intermittently depending on the combustible gas concentration. The interval of the intermittent buzzer varies in six steps depending on the concentration, with briefer intervals for higher gas concentrations.

		Gas concentration			
Full scale (F.S.)		500 ppm	1,000 ppm	2,000 ppm	5,000 ppm*
Buzzer interval	Approx. 0.5 seconds	30 ppm or higher	60 ppm or higher	120 ppm or higher	300 ppm or higher
	Approx. 0.25 seconds	50 ppm or higher	100 ppm or higher	200 ppm or higher	500 ppm or higher
	Approx. 0.15 seconds	100 ppm or higher	200 ppm or higher	400 ppm or higher	1,000 ppm or higher
	Approx. 0.1 seconds	200 ppm or higher	400 ppm or higher	800 ppm or higher	2,000 ppm or higher
	Approx. 0.05 seconds	300 ppm or higher	600 ppm or higher	1,200 ppm or higher	3,000 ppm or higher
	Approx. 0.01 seconds	400 ppm or higher	800 ppm or higher	1,600 ppm or higher	4,000 ppm or higher

* Can be selected only when the detection target gas is methane (CH₄).

<Full scale selection method>

- 1 Press the DISP button on the concentration display screen. Pressing the button cycles through the full scales.

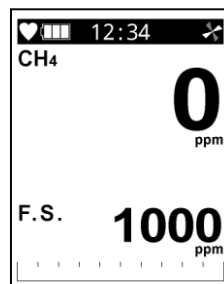
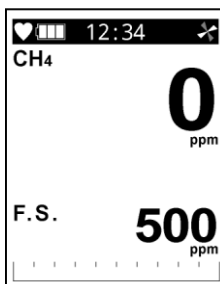
**NOTE**

- ▶ The reading may blink while measurement is underway in leak check mode. When the reading blinks, this is not a fault but indicates that the full scale is being switched and measurement is continuing.

<Peak hold function>

The peak reading (maximum value) for any period can be displayed on the screen.

- 1 Press the RESET button. [PEAK] appears in the center of the screen. The peak reading value after pressing the RESET button is displayed to the right. Pressing the RESET button again clears the [PEAK] display and resets the peak value.

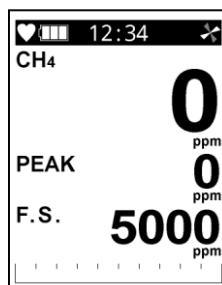

5-5-3 Benzene select mode (VOC sensor (10.0 eV) only)

If a VOC sensor (10.0 eV) is installed, in addition to VOC concentration measurement in normal mode, benzene select mode increases selectivity for benzene and allows measurement of benzene concentration. In benzene select mode, the benzene measurement pre-filter tube (CF-8338) and tube holder (GF-284) are attached for measurement. Attach the pre-filter tube and tube holder to the product following the procedure below.



CAUTION

- Read the instruction manual provided with the pre-filter tube (CF-8338) before use.
- In cold environments, the rubber seal on the tube holder will become hard, making it difficult to attach the pre-filter. Attach the pre-filter to the tube holder at room temperature, and try to minimize the duration for which it is used in cold environments.
- When using the pre-filter tube for measurement, set the calibration code beforehand. (See '<Entering the pre-filter tube calibration code>' in this section.)

NOTE

- ▶ When using the separately sold gas sampling tube (75 cm, part no. 0914 0141 30), connect the tapered nozzle first, followed by the tube holder, gas sampling tube, and then the product.
- ▶ For information on how to select benzene select mode, see '<6-4-3 Switching to benzene select mode>'.

<Pre-filter tube and tube holder attachment procedure>

1 Cut both ends of the pre-filter tube.

Insert the end of the pre-filter tube into the tube cutter opening, then rotate the pre-filter tube once. Hold the pre-filter tube near the base and bend toward you to break off the tip.

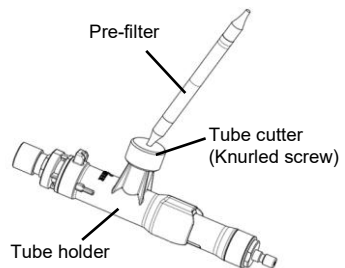

2 Remove the tube holder cap.

Pull the cap while pushing the tabs on the cap.

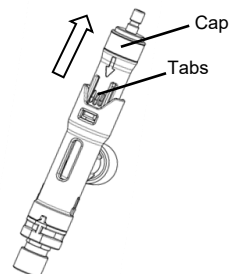

3 Insert the pre-filter tube.

Insert until the hatched area on the label affixed to the pre-filter tube is no longer visible.

<Correctly inserted>
Hatched area not visible

<Incorrectly inserted>
Hatched area visible

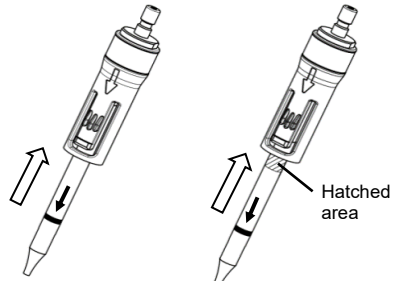

4 Attach the cap to the tube holder.

Insert firmly until the cap clicks into place.

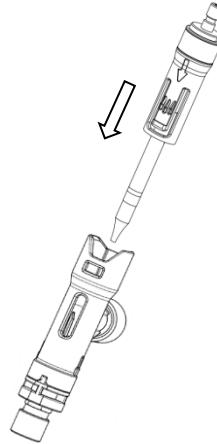

5 Attach the tube holder to the product.

Attach the tapered nozzle, followed by the tube holder, and then the product.

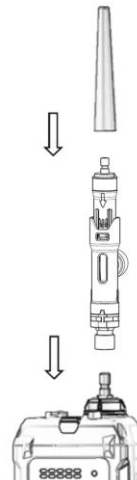

<Detaching the tube cutter>

You can remove glass fragments cut using the tube cutter by detaching the tube cutter. Detach the tube cutter periodically to dispose of the glass fragments.

**CAUTION**

- To prevent the glass fragments inside from falling out, make sure the rubber cap is fitted fully over the tube cutter after attaching or detaching.

1 Detach the rubber cap and tube cutter from the tube holder.

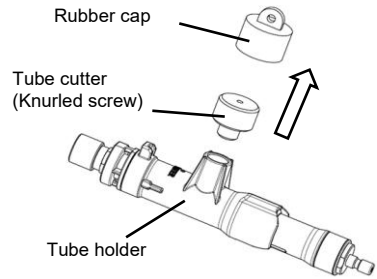

2 Remove the glass fragments.

3 Rotate the tube cutter to secure it into place, then attach the rubber cap to the tube cutter.

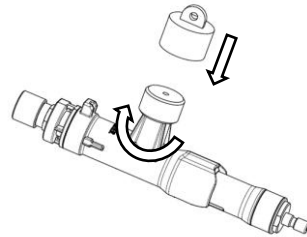

<Entering the pre-filter tube calibration code>

Set the calibration code (printed on the pre-filter packaging) in the product to perform measurement with the pre-filter (CF-8338).

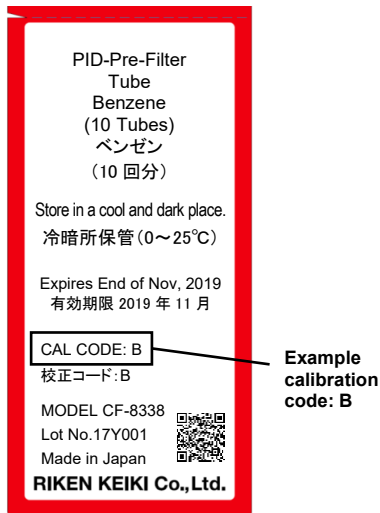

Example package labeling

- 1 **Turn off the power.**
Hold down the POWER/ENTER button.
- 2 **Press the POWER/ENTER and ▲/AIR buttons or the POWER/ENTER, ▲/AIR, and SHIFT/▼ buttons simultaneously.**
- 3 **Release the buttons when the buzzer blips once.**
The power turns on and the [MODE SELECT] screen is displayed.
- 4 **Press the ▲/AIR or SHIFT/▼ button to select [USER MODE].**
- 5 **Press the POWER/ENTER button.**
The user mode menu appears.

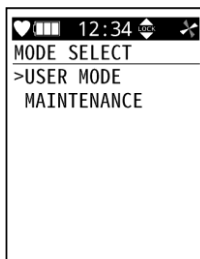

- 6 Press the ▲/AIR or SHIFT/▼ button to select [CALIBRATION], then press the POWER/ENTER button.

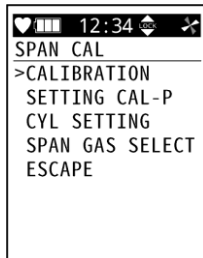

- 7 Press the ▲/AIR or SHIFT/▼ button to select [SPAN CAL], then press the POWER/ENTER button.

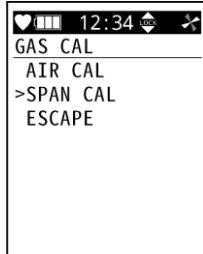

- 8 Press the ▲/AIR or SHIFT/▼ button to select [CAL CODE], then press the POWER/ENTER button.

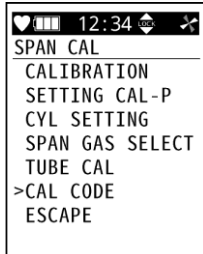

- 9 Press the ▲/AIR or SHIFT/▼ button to enter the calibration code indicated on the pre-filter packaging.

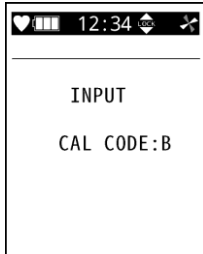

- 10 Press the POWER/ENTER button to confirm. [END] appears, and the display returns to the screen in Step 8.



5-6 Performing fresh air adjustment

Perform fresh air adjustment in normal mode and leak check mode before measuring gas concentrations.

NOTE

- ▶ Leak check mode can be used only if an SHS sensor is installed.
- ▶ If an SHS sensor is installed, fresh air adjustment must be performed in both normal mode and leak check mode. (For information on how to select normal mode and leak check mode, see '5-5 Detection modes'.)
- ▶ If a VOC sensor is installed, use the activated carbon filter CF-8350 to remove volatile organic compounds (VOCs) from the air during fresh air adjustment in normal mode.
- ▶ In benzene select mode, fresh air adjustment is not performed, and the results of fresh air adjustment in normal mode are used.
Before measuring in benzene select mode, perform fresh air adjustment in normal mode.



WARNING

<Normal mode / Leak check mode>

- When fresh air adjustment is performed in the surrounding atmosphere, check the air for cleanness before starting. Correct fresh air adjustment will not be possible in the presence of miscellaneous gases. It is also extremely dangerous if the product cannot detect actual gas leaks correctly.

<Normal mode only / If a VOC sensor is installed>

- If a VOC sensor is installed, attach the activated carbon filter CF-8350 for fresh air adjustment.



CAUTION

<Normal mode / Leak check mode>

- Perform fresh air adjustment in an environment that meets all of the following conditions:
 - Under conditions of pressure, temperature, and humidity similar to those in the usage environment
 - In clean air
- Wait for the reading to stabilize before performing fresh air adjustment.
- If the temperature difference between the storage location and usage location is 15 °C or greater, turn on the power and allow the product to adjust to ambient conditions similar to those at the usage location for about 10 minutes. After this, perform fresh air adjustment in clean air before use.

<Normal mode only / If a VOC sensor is installed>

- Use the activated carbon filter held upright. Drawing in air with the filter oriented horizontally may prevent removal of miscellaneous gas from the air, as the gas passes through the upper part inside the activated carbon filter tube.
- After using the activated carbon filter, attach the cap to block the air flow.
- Heating the activated carbon filter may release large amounts of miscellaneous gas previously absorbed in the activated carbon filter. If the product draws in this released miscellaneous gas, it will reduce the service life of the filter inside the detector. Avoid using the product in environments with high levels of miscellaneous gas, and be sure to replace the filter at the stipulated intervals.

<Normal mode only / If a carbon dioxide sensor is installed>

- By default, fresh air adjustment is not performed on carbon dioxide sensors. To adjust the zero point for a carbon dioxide sensor, CO₂ zero adjustment must be performed.
- Perform CO₂ zero adjustment at regular intervals. Also perform CO₂ zero adjustment if the carbon dioxide reading deviates significantly from the typical atmospheric carbon dioxide concentration range of 400 – 500 ppm, even in fresh air. (See '8-2-3 Performing CO₂ zero adjustment'.)
- To perform fresh air adjustment for the carbon dioxide sensor, enable the CO₂ fresh air adjustment setting in user mode. (See '7-5-1 Enabling/disabling CO₂ fresh air adjustment'.)
When the CO₂ fresh air adjustment setting is enabled and fresh air adjustment is performed, the carbon dioxide sensor will be automatically set to 400 ppm for the air drawn in regardless of the actual carbon dioxide concentration. Although the concentration of carbon dioxide in the atmosphere is typically around 400 – 500 ppm, correct adjustment may not be possible depending on the environmental carbon dioxide level. Therefore, we recommend adjustment using CO₂ zero adjustment. (See '8-2-3 Performing CO₂ zero adjustment'.)
- Do not enable the CO₂ fresh air adjustment setting if an VOC sensor is installed. Correct adjustment will not be possible due to the carbon dioxide generated from the activated carbon filter CF-8350.

To install the activated carbon filter CF-8350, remove the caps on both ends and attach with the arrow on the side pointing toward the gas inlet (GAS IN) of the main unit.

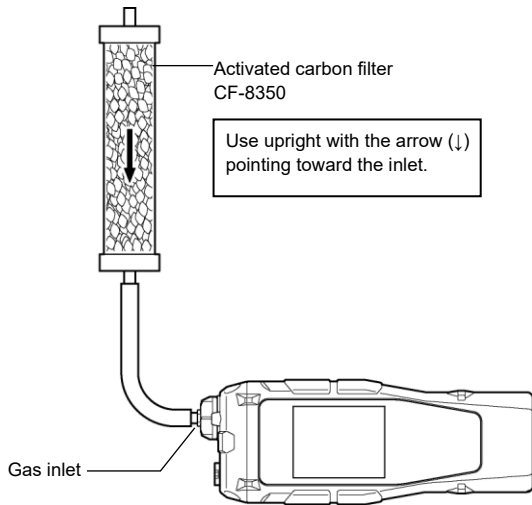

- 1 **Hold down the ▲/AIR button on the on the concentration display screen.**
The fresh air adjustment screen is displayed.
Hold down the ▲/AIR button for as long as the screen shown on the right is displayed.

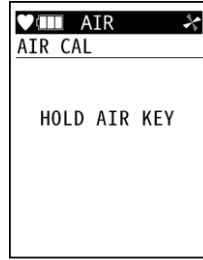

- 2 **Release the ▲/AIR button once [RELEASE AIR KEY] appears on the screen.**

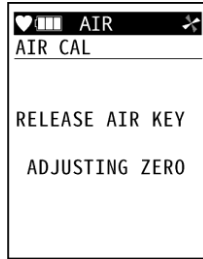

The display automatically returns to the measurement screen once fresh air adjustment has been successfully completed.

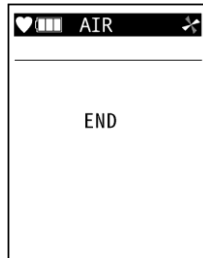

NOTE

- ▶ If fresh air adjustment fails, fresh air adjustment is not performed, and [FAIL] appears in the concentration display area for the failed sensor. Press the RESET button to reset the fault alarm (adjustment failure). Resetting the alarm displays the value prior to fresh air adjustment.

5-7 Gas detection



DANGER

Usage

- If measuring inside manholes or enclosed spaces, never lean over or look into the manhole or enclosed space. There is a danger that oxygen-deficient air or other gases may be discharged from such locations.

Gas outlet

- Oxygen-deficient air or other gas may be discharged from the gas outlet. Never breathe in this air.
- High-concentration gas may be discharged. Be sure to maintain a safe distance from flame sources.



WARNING

- The product is designed to draw in gas at atmospheric pressure. There is a danger that detection target gas may leak from inside the product if an excessive pressure is applied to the product gas inlet (GAS IN) or outlet (GAS OUT). Be careful to avoid excessive pressure during use.
- Do not connect the tapered nozzle directly to locations subject to a pressure greater than atmospheric pressure. Doing so may result in damage to the internal piping.
- When fresh air adjustment is performed in the surrounding atmosphere, check the air for cleanliness before starting. The presence of miscellaneous or interference gases will make it impossible to adjust the product correctly, resulting in the danger of erroneous detection when actual gas leaks occur.
- A gas alarm indicates the presence of extreme danger. The user must take appropriate action.
- Check the battery level before using the product. The batteries may be depleted when the product is used for the first time or after extended periods without use. Always fully charge or replace with new batteries before use.
- Gas measurement will not be possible if a battery low voltage alarm occurs. If the alarm occurs during use, turn off the power and promptly charge or replace the batteries in a safe place.
- Do not block the buzzer sound opening. Doing so will muffle or silence the audible warning.



CAUTION

- Check the product settings before starting gas measurement.
- The new ceramic type combustible gas sensor (NCR sensor) may be negatively impacted by continuously measuring high concentrations of combustible gases that exceed the full-scale range for an extended period. Avoid use for extended periods in environments where high concentrations of combustible gases are present. If a thermal conductivity type combustible gas sensor (TE sensor) is installed, set the range to [VOL ONLY]. Switching to the thermal conductivity type combustible gas sensor (TE sensor) will have no adverse effects, as the new ceramic type combustible gas sensor (NCR sensor) is not used for measurement. (For information on how to set the range, see '6-4-1 Setting the combustible gas sensor range'.)
- Do not expose the product to sudden pressure fluctuations. Oxygen (O₂) readings will vary temporarily, preventing accurate measurement.
- If highly adsorptive gas has been sucked in, allow the product to suck in clean air, and confirm that the reading returns to zero before use.

- When measuring highly adsorptive gases, be aware that measuring at a flow rate lower than the specified flow rate (0.45 L/min) may result in readings lower than the actual concentration of the detection target gas at the measurement point.
- Due to the properties of the gases, response to chlorine (Cl₂) and ammonia (NH₃) may slow near the lower limit (around -20 °C) of the operating temperature range.
- Some sensors may exhibit positive sensitivity to gases other than the detection target gas.
Note that when the product is used in an environment where such gases are present, the reading may be higher than the actual concentration of the detection target gas present.

<Examples of interference gases to which the sensor exhibits positive sensitivity>

Sensor type	Detection target gas name	Interference gas
NCR sensor (New ceramic type)	Methane (CH ₄)/ isobutane (HC (i-C ₄ H ₁₀))	All combustible gases
DES sensor (Non-dispersive infrared type (NDIR))	Methane (CH ₄)/ isobutane (HC (i-C ₄ H ₁₀))	Hydrocarbon combustible gases
SHS sensor (Hot-wire semiconductor type)	Methane (CH ₄)/ isobutane (HC (i-C ₄ H ₁₀))	All gases
TE sensor (Thermal conductivity type)	Methane (CH ₄)/ isobutane (HC (i-C ₄ H ₁₀))	All combustible gases
ESS sensor (Electrochemical type)	Hydrogen cyanide (HCN)	Hydrogen sulfide (H ₂ S)
ESS sensor (Electrochemical type)	Hydrogen cyanide (HCN)	Sulfur dioxide (SO ₂)
ESS sensor (Electrochemical type)	Hydrogen cyanide (HCN)	Acetylene (C ₂ H ₂)
ESS sensor (Electrochemical type)	Hydrogen cyanide (HCN)	Phosphine (PH ₃)
ESS sensor (Electrochemical type)	Sulfur dioxide (SO ₂)	Hydrogen (H ₂)
ESS sensor (Electrochemical type)	Sulfur dioxide (SO ₂)	Carbon monoxide (CO)
ESS sensor (Electrochemical type)	Carbon monoxide (CO)	Hydrogen (H ₂)
ESS sensor (Electrochemical type)	Chlorine (Cl ₂)	Sulfur dioxide (SO ₂)
ESS sensor (Electrochemical type)	Chlorine (Cl ₂)	Hydrogen chloride (HCl)
ESS sensor (Electrochemical type)	Phosphine (PH ₃)	Sulfur dioxide (SO ₂)
ESS sensor (Electrochemical type)	Phosphine (PH ₃)	Hydrogen cyanide (HCN)
ESS sensor (Electrochemical type)	Phosphine (PH ₃)	Hydrogen sulfide (H ₂ S)
PIS sensor (Photoionization type (PID))	Volatile organic compounds (VOCs)	All volatile organic compounds (VOCs)

- Due to their operating principle, electrochemical type sensors may exhibit negative sensitivity to certain interference gases. In environments where interference gases are present, the reading may be lower than the actual concentration of the detection target gas present, and particularly at high concentrations, the reading may even turn negative, triggering an M OVER alarm. (See '12-5 List of interference gases for electrochemical type sensors'.)

- Note that if a new ceramic type combustible gas sensor (NCR sensor) is used in an environment where silicone compounds, halides, high-concentration sulfides, or high-concentration solvent gases are present, sensor life may be reduced, sensitivity to combustible gases may deteriorate, and accurate readings may not be obtained.
If use in such environments is unavoidable, use for the shortest possible time and allow the product to suck in fresh air afterward. Confirm that the reading returns to normal and is stabilized.
- An oxygen concentration of at least 10 vol% is required in order for the new ceramic type combustible gas sensor (NCR sensor) in the product to accurately measure and display gas concentrations.
- Due to the way the sensor operates, an accurate reading may not be displayed immediately after turning on the power. Allow the product to warm up for at least one minute after turning on the power to allow the reading to stabilize before use. Allow the product to warm up for at least 10 minutes after turning on the power before performing gas adjustment.
- The reading of the carbon monoxide sensor may rise if exposed to high concentrations of volatile organic compounds (VOCs). If the reading rises and will not return, the activated carbon filter in the carbon monoxide sensor must be replaced. For information on activated carbon filter replacement, contact RIKEN KEIKI.
- Carbon monoxide sensors and hydrogen sulfide sensors may exhibit temporary reading fluctuations if exposed to sudden temperature or humidity variations. Allow the sensors to acclimatize adequately to the ambient environment and perform fresh air adjustment.
- The sensitivity of carbon monoxide sensors and hydrogen sulfide sensors may be reduced temporarily if they come into contact with high-concentration gas exceeding the display range. If the sensor has come into contact with high-concentration gas, be sure to allow it to suck in fresh air and perform air cleaning.
- The hydrogen sulfide sensor may exhibit temporary fluctuations if exposed to sudden temperature variations. Allow the product to stand and acclimatize in the ambient atmosphere before use.
- If the VOC sensor is exposed to high concentrations of methane (CH₄), ethane (C₂H₆), propane (C₃H₈), or other gases, [----] may appear in the concentration display area, and measurement may be temporarily disabled. In environments where these gases are present, even if the concentration display does not indicate [----], be aware that the VOC concentration may not be accurately measured. Even if the VOC sensor concentration display indicates [----], other unaffected sensors can continue measurement.

<Example interference gases causing [----] to be displayed in the VOC sensor concentration display area>

Interference gas	Concentration
Methane (CH ₄)	6 vol% or more
Ethane(C ₂ H ₆)	80 vol% or more
Propane (C ₃ H ₈)	90 vol% or more

- Do not use the separately sold tubes or filters if an ESS sensor or VOC sensor is installed, even though recommended above, due to the risk of adsorption.
- Readings close to the zero level are subject to processing to minimize fluctuations. For more information, see '12-3 Zero suppression function'.

NOTE

- ▶ The carbon monoxide sensor (ESR-A1CP) includes a correction function to reduce interference due to hydrogen. This function works for hydrogen concentrations up to 2,000 ppm. If hydrogen is detected at a concentration of 2,000 ppm or higher, [RICH] is displayed in the concentration display area. While measurement can continue, large errors will arise with carbon monoxide concentration readings due to the significant effects of hydrogen interference.

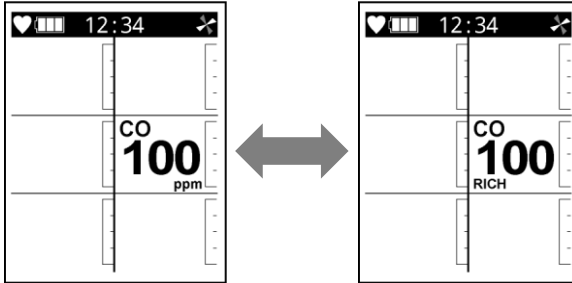

- ▶ The refresh intervals for each sensor gas concentration display are as follows:

Sensor type (detection principle)	Gas concentration display refresh interval
NCR sensor (new ceramic type)	Every 5 seconds
ESR/ESS sensor (electrochemical type)	Every second
TE sensor (thermal conductivity type)	Every 8 seconds
DES sensor (non-dispersive infrared type (NDIR))	Every 4 seconds
PIS sensor (photoionization type (PID))	Every second
SHS sensor (hot-wire semiconductor type)	Every second

5-7-1 Measuring gas concentration

Measure the gas concentration in normal mode, leak check mode, or benzene select mode.

<Normal mode>

Bring the tapered nozzle close to the measurement location. The product sucks in the detection target gas, and the measurement results are displayed on the LCD.

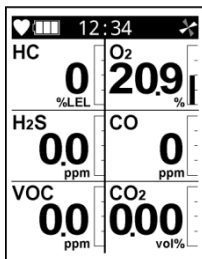

<Leak check mode>

Bring the tapered nozzle close to the measurement location. The product sucks in the detection target gas, and the measurement results are displayed on the LCD. (For information on how to enter leak check mode, see '5-5 Detection modes'.)

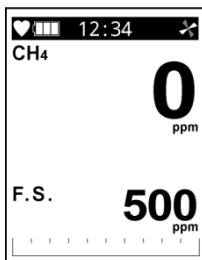

<Benzene select mode>

Enter benzene select mode. Attach the pre-filter tube and tube holder, bring the tapered nozzle close to the detection area, then read off the measurement results displayed on the LCD. (For information on how to enter benzene select mode, see '6-4-3 Switching to benzene select mode'.)

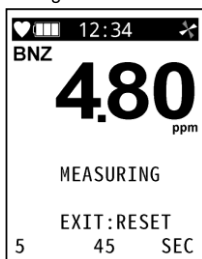



CAUTION

<Benzene select mode>

- The time taken for measurement differs depending on the temperature. Read off the measurement results after the specified measurement time elapses. For information on the measurement procedure, see '6-4-3 Switching to benzene select mode'.
- While in benzene select mode, sensors other than the VOC sensor are deactivated and gas alarms will not be triggered by those sensors.

NOTE

- ▶ The operating time will be reduced due to battery performance in cold environments at -10 °C or below.
- ▶ The response of the LCD may slow at low temperatures.
- ▶ If combustible gas is drawn in at high concentrations of 100 %LEL or above, gas adsorbed inside the tapered nozzle or separately sold gas sampling tube and gas sampling rod may remain inside. After drawing in high-concentration combustible gas, always draw in fresh air and perform air cleaning until the reading returns to around zero to remove any adsorbed gas. Performing fresh air adjustment before complete cleaning may prevent accurate fresh air adjustment and may adversely affect detection. In this case, adjustment failure can be prevented by first detaching the separately sold items such as the tapered nozzle and gas sampling tube, and then performing fresh air adjustment.

Sensors

- ▶ If the combustible gas reading exceeds 100 %LEL, the carbon monoxide (CO) reading will rise temporarily, but this is not an abnormality.
- ▶ When measuring in locations where combustible gas may be present at high concentrations, measure using the vol% range. For information on how to configure the settings, see '6-4-1 Setting the combustible gas sensor range'.
- ▶ If the oxygen concentration falls below 10 %, [----] will appear in the combustible gas concentration display area for the new ceramic type combustible gas sensor (NCR sensor). If the range setting for the new ceramic type combustible gas sensor (NCR sensor) and thermal conductivity type combustible gas sensor (TE sensor) is [AUTO RANGE] (default setting), the concentration display will switch to that for the thermal conductivity type combustible gas sensor (TE sensor). If [LEL ONLY] is set, measurement will not be performed. Reassess the usage environment. (See '6-4-1 Setting the combustible gas sensor range'.)
- ▶ If the oxygen sensor (ESR-X13P) is not installed and the combustible gas concentration is fixed in the %LEL range, the OVER alarm will remain fixed if the measured combustible gas concentration exceeds 100 %LEL.
To reset the alarm, press the RESET button in the presence of fresh air. The concentration display resumes a short while after pressing the RESET button.

<The effects of coexisting gas on high-concentration combustible gas sensors>

- ▶ Thermal conductivity type sensors (TE sensors) used to measure high-concentration combustible gas rely on differences in the thermal conductivity of gases. Readings may therefore be affected if high concentrations of gases other than combustible gases are present in the air.

5-7-2 Combustible gas concentration range changeover points

If all of the following conditions are met, the range will automatically switch when the measured combustible gas concentration exceeds the full scale. (See '1-3 Checking the detection target gases and product specifications' and '6-4-1 Setting the combustible gas sensor range'.)

<In normal mode>

- If multiple combustible gas sensors are installed at the same time (%LEL range and vol% range sensors)
- If the detection target gas for the combustible gas sensors is the same
- If the range for the combustible gas sensors is set to [AUTO RANGE] (default setting)

<In leak check mode>

- If multiple combustible gas sensors are installed at the same time (ppm range, %LEL range, and vol% range sensors)
- If the detection target gas for the combustible gas sensors is the same

NOTE

- ▶ If using sensors that rely on different principles, the readings may not coincide temporarily in the vicinity of the changeover point.

<New ceramic type sensor (NCR sensor)/thermal conductivity type sensor (TE sensor)/non-dispersive infrared type sensor (DES sensor)>

The range changeover point is at the gas lower explosive limit (LEL), and the value varies depending on the gas type and model.

The following is an example for isobutane (HC (i-C₄H₁₀)).

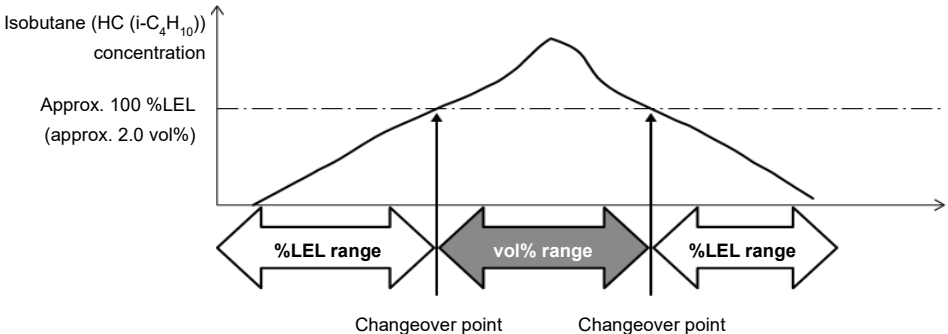

<Hot-wire semiconductor type sensor (SHS sensor)>

The range changeover point is at the SHS sensor full scale value, and varies depending on the gas type. The full scale value is displayed at startup. (See '5-4 Turning on the power'.) The following is an example for isobutane (HC (i-C₄H₁₀)).

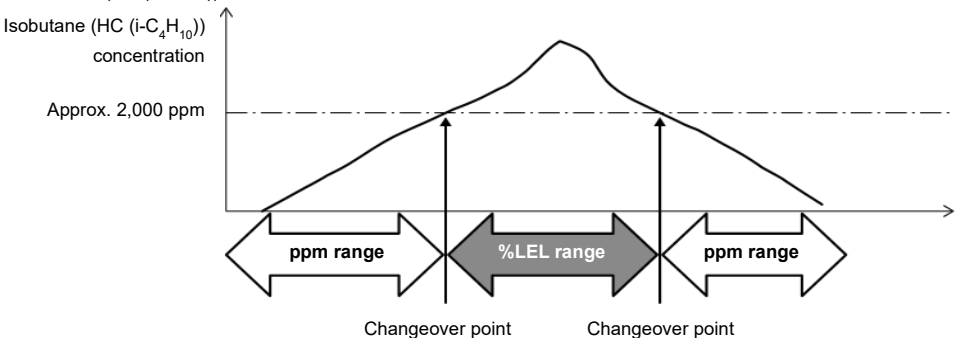

5-7-3 Confirmation beep operation

The confirmation beep is a function that provides audible notification upon bump test expiration or after the occurrence of a gas alarm when the product is operating normally.

The buzzer and LEDs operate at preset intervals while measurement is underway.

NOTE

- ▶ The confirmation beep operates only in measurement mode and display mode.
- ▶ If a gas alarm has occurred, the gas alarm takes precedent.
- ▶ The confirmation beep operation can be modified in the configuration program.

The buzzer and LEDs operate as follows depending on the confirmation beep operation type. The default setting is [OFF].

- [OFF]: Do not operate.
- [LED]: The LEDs operate twice at the set operating time interval.
- [BUZZER]: The buzzer sounds twice at the set operating time interval.
- [LED+BUZZER]: The LEDs and buzzer operate twice at the set operating time interval.
- [BUMP/CAL]: The LEDs light up for one second at the set operating time interval when the span adjustment has expired with the adjustment expiration function enabled or when the bump test has expired with the bump test expiration function enabled. The buzzer and LEDs continue to operate even when the product is restarted until span adjustment or a bump test has been performed for all of the installed sensors.
- [ALM ALRT]: The LEDs light up for one second at the set operating time interval when a gas alarm (including negative sensor failure) occurs. The buzzer and LEDs continue to operate, even if the product is restarted, until span adjustment or a bump test has been performed for all of the installed sensors.
- [B/C/ALM]: The LEDs light up for one second at the set operating time interval when a gas alarm (including negative sensor failure) occurs when the span adjustment has expired with the adjustment expiration function enabled or when the bump test has expired with the bump test expiration function enabled. The buzzer and LEDs continue to operate even when the product is restarted until span adjustment or a bump test has been performed for all of the installed sensors.

5-8 Recording gas concentration logs (snap logger)

In normal mode and leak check mode, up to 256 user-specified gas concentration values can be recorded while measurement is in progress. If more than 256 data items are recorded, the oldest data is overwritten.

- 1 **Hold down the ▲/AIR and SHIFT/▼ buttons simultaneously (for approximately two seconds) on the normal mode or leak check mode concentration display screen.**

The display cycles through the memory number, gas concentration to be recorded, recording date and time, and station ID.

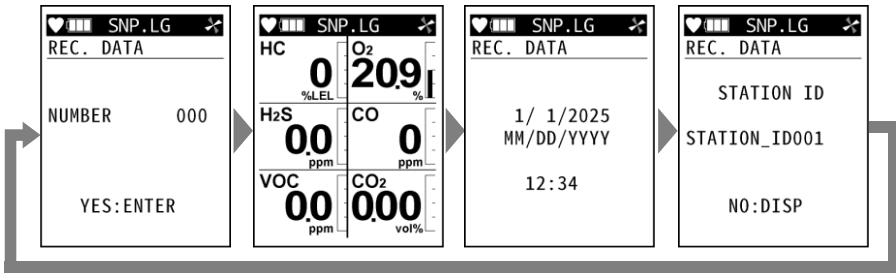

- 2 **Press the POWER/ENTER button.**

[END] appears on the screen. The memory number, station ID, date and time, and gas concentration at the time the POWER/ENTER button is pressed will be recorded.

To continue recording, press the POWER/ENTER button.

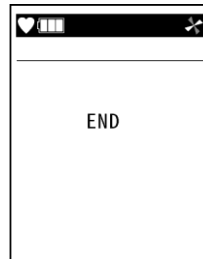

- 3 **To exit, press the DISP button.**

The display returns to concentration display screen.

NOTE

- ▶ The recorded data can be checked on the snap logger display screen in display mode. (See '6-3-2 Displaying the snap logger (gas concentration/alarm status)').

5-9 Turning off the power



CAUTION

- If the concentration display does not return to zero (20.9 % for the oxygen concentration display or around 400 – 500 ppm for the carbon dioxide concentration display) after measurement ends, allow the product to stand in fresh air until the display returns to zero before turning off the power.
- If the product is dirty, wipe it with a cloth or similar.
- When wiping the product clean, do not use organic solvents like alcohol or benzene.

- 1 **Hold down the POWER/ENTER button (for at least three seconds).**
The buzzer blips three times and [TURN OFF] appears on the display before the power turns off.



NOTE

- ▶ When turning off the power, hold down the button until the buzzer blips three times.
- ▶ If the display has not returned to zero when you turn off the power, purging will be performed for up to 30 seconds to clean the product interior. The screen as shown on the right is displayed while purging is in progress.





6

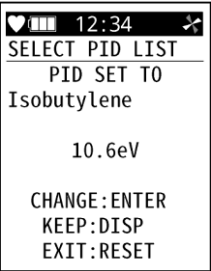
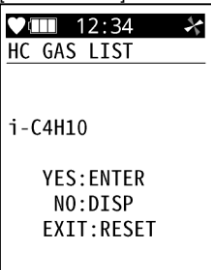

Settings (Display Mode)

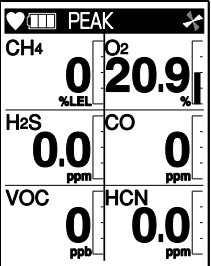
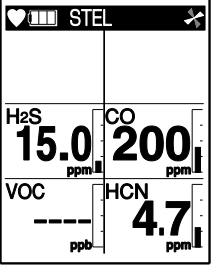
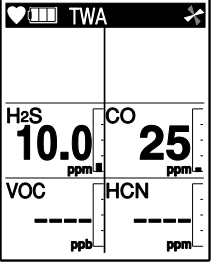

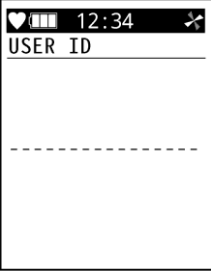
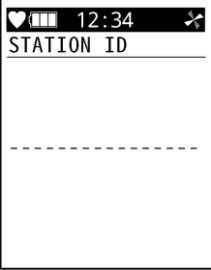
6-1 Display mode items

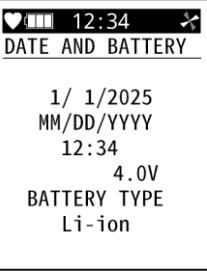
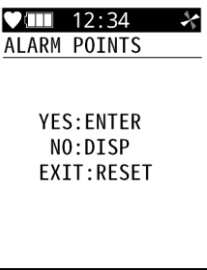

LCD display	Description	Reference
<p>[BENZENE SELECT]</p>  <p>BENZENE SELECT</p> <p>YES:ENTER NO:DISP EXIT:RESET</p>	<p>Benzene can be selectively measured using the separately sold pre-filter. Displayed only when a VOC sensor (10.0 eV) is installed</p>	<p>6-4-3 Switching to benzene select mode</p>
<p>[SELECT PID LIST]</p>  <p>SELECT PID LIST</p> <p>PID SET TO Isobutylene</p> <p>10.6eV</p> <p>CHANGE:ENTER KEEP:DISP EXIT:RESET</p>	<p>Displays the volatile organic compound (VOC) concentration after converting it to the concentration of the conversion gas registered in the product.</p>	<p>6-4-4 Volatile organic compound (VOC) conversion gas selection</p>
<p>[HC GAS LIST]</p>  <p>HC GAS LIST</p> <p>i-C4H10</p> <p>YES:ENTER NO:DISP EXIT:RESET</p>	<p>Displays the combustible gas concentration after converting it to the concentration of the conversion gas registered in the product. Displayed when all of the following conditions are satisfied:</p> <ul style="list-style-type: none"> • A new ceramic type combustible gas sensor (NCR sensor) is installed. • No thermal conductivity type combustible gas sensor (TE sensor) is installed. 	<p>6-4-2 Combustible gas conversion gas selection</p>

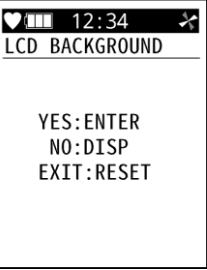
LCD display	Description	Reference
<p>[HC RANGE SELECT]</p> 	<p>Set the range selection method for the new ceramic type combustible gas sensor (NCR sensor) and thermal conductivity type combustible gas sensor (TE sensor) detection target gas concentrations. Displayed only if a new ceramic type combustible gas sensor (NCR sensor) and thermal conductivity type combustible gas sensor (TE sensor) are installed</p>	<p>6-4-1 Setting the combustible gas sensor range</p>
<p>[PEAK]</p> 	<p>Displays the maximum gas concentration (or minimum concentration for L-LL-H alarm type) measured since the power was turned on.</p>	<p>6-3-1 Displaying/clearing the peak value</p>
<p>[STEL]</p> 	<p>Displays the STEL value for 15-minute period prior to the current time (or since the power was turned on). The STEL value refers to the sum of 15 pieces of average value data for measured values over a period of 60 seconds divided by 15. The value is refreshed every 60 seconds. [---] is displayed when "OFF" is indicated in the STEL alarm setpoint column. (See '4-2 Gas alarm setpoints'.)</p>	<p>-</p>
<p>[TWA]</p> 	<p>Displays the TWA value for 8-hour period prior to the current time (or since the power was turned on). The TWA value refers to the value obtained by integrating average value data for measured values over a period of 60 seconds and then dividing the integrated value for a period of 8 hours by 480. The value is refreshed every 60 seconds. [---] is displayed when "OFF" is indicated in the TWA alarm setpoint column. (See '4-2 Gas alarm setpoints'.)</p>	<p>-</p>

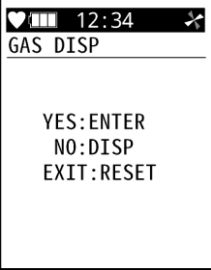
LCD display	Description	Reference
<p>[USER ID]</p> 	Set the user ID.	6-4-5 Setting the user ID
<p>[STATION ID]</p> 	Set the station ID.	6-4-6 Setting the station ID
<p>[REC DATA DISP]</p> 	Displays the gas concentration and alarm status recorded by the snap logger function.	6-3-2 Displaying the snap logger (gas concentration/alarm status)
<p>[PUMP OFF]</p> 	Allows the pump operation to be stopped temporarily for 10 minutes.	-

LCD display	Description	Reference
<p>[DATE AND BATTERY]</p>  <p>The LCD display shows a status bar at the top with a heart icon, a battery level indicator, and the time 12:34. Below the status bar, the text reads: DATE AND BATTERY, 1/ 1/2025, MM/DD/YYYY, 12:34, 4.0V, BATTERY TYPE, and Li-ion.</p>	<p>Displays the current date and time (MM/DD/YYYY/ hours/minutes). Also indicates the battery type and battery level.</p>	<p>-</p>
<p>[ALARM POINTS]</p>  <p>The LCD display shows a status bar at the top with a heart icon, a battery level indicator, and the time 12:34. Below the status bar, the text reads: ALARM POINTS, YES: ENTER, NO: DISP, and EXIT: RESET.</p>	<p>Displays the full-scale value, first alarm setpoint, second alarm setpoint, third alarm setpoint, STEL alarm setpoint, and TWA alarm setpoint for each sensor. Also allows the alarm operation to be checked.</p>	<p>6-3-3 Displaying alarm setpoints</p>
<p>[INVERT SELECT]</p>  <p>The LCD display shows a status bar at the top with a heart icon, a battery level indicator, and the time 12:34. Below the status bar, the text reads: INVERSION SELECT, YES: ENTER, NO: DISP, and EXIT: RESET.</p>	<p>Inverts the LCD display by 180 degrees depending on the orientation of the product.</p>	<p>6-4-7 LCD inversion setting</p>
<p>[LCD BACKGROUND]</p>  <p>The LCD display shows a status bar at the top with a heart icon, a battery level indicator, and the time 12:34. Below the status bar, the text reads: LCD BACKGROUND, YES: ENTER, NO: DISP, and EXIT: RESET.</p>	<p>Inverts black and white of the LCD screen background.</p>	<p>6-4-8 LCD background setting</p>

LCD display	Description	Reference
<p>[PEAK BAR]</p>  <p>YES:ENTER NO:DISP EXIT:RESET</p>	<p>Set whether to make the peak value blink in the bar display to the right of the gas concentration on the measurement screen.</p>	<p>6-4-9 Peak bar display setting</p>
<p>[GAS DISP]</p>  <p>YES:ENTER NO:DISP EXIT:RESET</p>	<p>Set the display method on the measurement screen. For a single-screen display, set whether to switch the display automatically or manually.</p>	<p>6-4-10 Measurement gas scroll setting</p>
<p>[BLUETOOTH]</p>  <p>YES:ENTER NO:DISP EXIT:RESET</p>	<p>Set the connection to a Bluetooth device when the Bluetooth function is enabled.</p>	<p>6-4-11 Setting a Bluetooth device connection</p>
<p>[BUZZER VOLUME]</p>  <p>YES:ENTER NO:DISP EXIT:RESET</p>	<p>Select the buzzer volume setting.</p>	<p>6-4-12 Setting the buzzer volume</p>

LCD display	Description	Reference
	<p>Returns the display language to Japanese. Displayed if a language other than Japanese is set with the Japan Ex model</p>	<p>6-4-13 Switching display language to Japanese (Japan Ex model)</p>
	<p>Returns the display language to English. Displayed if a language other than English is set with the ATEX/IECEx model</p>	<p>6-4-14 Switching display language to English (ATEX/IECEx model)</p>

6-2 Switching to display mode

- 1 Press the DISP button on the normal mode concentration display screen.

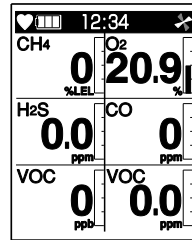

Pressing the DISP button displays the various setting item screens in sequence.

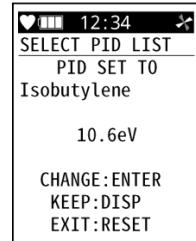
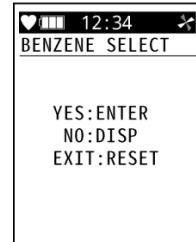

⋮

The display returns to the concentration display screen once the display mode item display has ended.

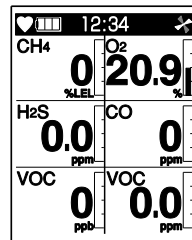

NOTE

- ▶ You can also jump between display mode items by holding down the DISP button.
- ▶ If no button is pressed for approximately 20 seconds in display mode, the display returns to the concentration display screen.

6-3 Checking settings

6-3-1 Displaying/clearing the peak value

This displays and clears the maximum gas concentration (or minimum oxygen (O₂) concentration) measured since the power was turned on.

NOTE

- ▶ The peak value is not displayed if the peak display function is disabled in [Disp mode item] in the configuration program. (The default setting is enabled.)

- 1 Press the DISP button several times on the concentration display screen in normal mode to display the [PEAK] screen.**
Displays the peak reading.

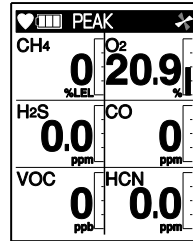

- 2 Hold down the RESET button (for approximately three seconds).**

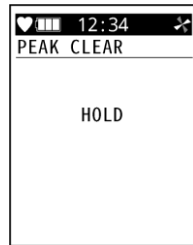

- 3 Release the RESET button once [RELEASE] appears on the screen.**
The peak value is cleared and the display returns to the screen in Step 1.



6-3-2 Displaying the snap logger (gas concentration/alarm status)

Displays the gas concentration and alarm status recorded by the snap logger function.

NOTE

- ▶ The snap logger is not displayed if the snap logger display function is disabled in [Disp mode item] in the configuration program. (The default setting is enabled.)

1 Press the DISP button several times on the concentration display screen in normal mode to display the [REC. DATA DISP] screen.

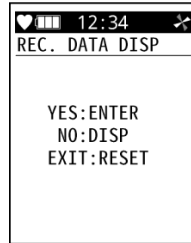

2 Press the POWER/ENTER button.
If you do not wish to display the snap logger, press the DISP button.

3 Press the ▲/AIR or SHIFT/▼ button to select the memory number to be displayed.

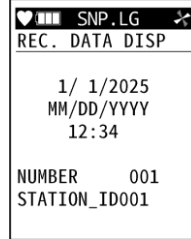

4 Press the POWER/ENTER button.
The data is displayed for the record number selected.

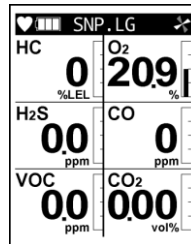

5 Press the DISP button.
The display returns to the screen in Step 3.
When you press the DISP button again, [END] appears, and the display returns to the screen in Step 1.

NOTE

- ▶ For information on the snap log recording procedure, see '5-8 Recording gas concentration logs (snap logger)'.
- ▶ [NO DATA] will be displayed if no snap logs are recorded. In this case, press the DISP button or POWER/ENTER button to return to the screen in Step 1.
- ▶ To cancel the snap logger display, press the DISP button in Step 4.

6-3-3 Displaying alarm setpoints

Displays the full-scale value ([F.S.]), first alarm setpoint ([AL1]), second alarm setpoint ([AL2]), third alarm setpoint ([AL3]), STEL alarm setpoint ([STEL]), and TWA alarm setpoint ([TWA]) for each sensor.

NOTE

- ▶ The alarm setpoints are not displayed if the alarm setpoint display function is disabled in [Disp mode item] in the configuration program. (The default setting is enabled.)

1 Press the DISP button several times on the concentration display screen in normal mode to display the [ALARM POINTS] screen.

2 Press the POWER/ENTER button.

If you do not wish to display the alarm setpoints, press the DISP button.

3 Press the ▲/AIR button.

Pressing the ▲/AIR button cycles through the alarm setpoints displayed.

Displayed in the sequence [F.S.] → [AL1] → [AL2] → [AL3] → [STEL] → [TWA] → [F.S.] → ...

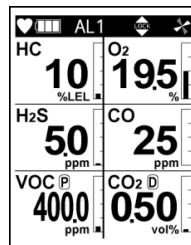
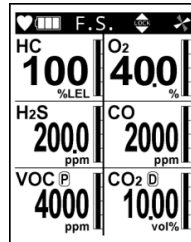
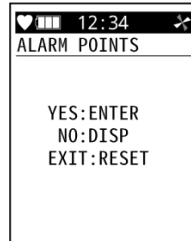

⋮

4 Press the DISP button.

The display returns to the screen in Step 1.

NOTE

- ▶ To perform an alarm test, press the POWER/ENTER button while an alarm setpoint is displayed. (See '8-4 Performing alarm tests'.)

6-4 Display mode settings

6-4-1 Setting the combustible gas sensor range

Set the range selection method for the new ceramic type combustible gas sensor (NCR sensor) and thermal conductivity type combustible gas sensor (TE sensor) detection target gas concentrations. Select one of the following:

- [AUTO RANGE]: The product will automatically switch from the new ceramic type combustible gas sensor (NCR sensor) to the thermal conductivity type combustible gas sensor (TE sensor) (vol% range) if the combustible gas concentration measured exceeds 100 %LEL.
- [VOL ONLY]: The combustible gas concentration is displayed only in the vol% range.
- [LEL ONLY]: The combustible gas concentration is displayed only in the %LEL range.



CAUTION

- The detection of combustible gases using a new ceramic type combustible gas sensor (NCR sensor) requires the presence of oxygen (O₂) in the measured gas. If it is clear that oxygen (O₂) is not present in the measured gas, such as combustible gases in a nitrogen (N₂) atmosphere, set the sensor range to [VOL ONLY] before measuring.

NOTE

- ▶ The default setting is [AUTO RANGE].
- ▶ The new ceramic type combustible gas sensor (NCR sensor) and thermal conductivity type combustible gas sensor (TE sensor) ranges can be set if a new ceramic type combustible gas sensor (NCR sensor) and thermal conductivity type combustible gas sensor (TE sensor) are installed. The item does not appear in display mode in other cases.
- ▶ The new ceramic type combustible gas sensor (NCR sensor) and thermal conductivity type combustible gas sensor (TE sensor) range settings are not stored. The setting immediately after turning on the power is [AUTO RANGE].
- ▶ If the combustible (NCR/TE) range selection function is disabled in [Disp mode item] in the configuration program, this setting item will no longer appear in display mode. (The default setting is enabled.)

- 1 Press the DISP button several times on the concentration display screen in normal mode to display the [HC RANG SELECT] screen.

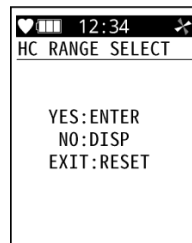

- 2 Press the POWER/ENTER button.
If you do not wish to set, press the DISP button.

- 3 Press the ▲/AIR or SHIFT/▼ button to select the NCR and TE sensor range selection method.
Select [AUTO RANGE], [VOL ONLY], or [LEL ONLY].

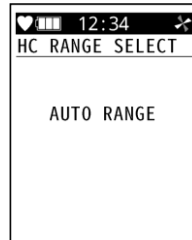

- 4 Press the POWER/ENTER button.
The NCR and TE sensor ranges are set.
[END] appears, and the display returns to the screen in Step 1.

NOTE

- ▶ To cancel the setting, press the DISP button in Step 4.

6-4-2 Combustible gas conversion gas selection

The combustible gas concentration can be displayed after converting it to the concentration of the conversion gas registered in the product.

NOTE

- ▶ Combustible gas conversion can be set only when all of the following conditions are satisfied:
 - A new ceramic type combustible gas sensor (NCR sensor) is installed.
 - No thermal conductivity type combustible gas sensor (TE sensor) is installed.
- ▶ The item does not appear in display mode if these conditions are not satisfied.
- ▶ The combustible gas conversion setting is retained even when the power is turned off.
- ▶ If the combustible gas conversion gas selection function is disabled in [Disp mode item] in the configuration program, this setting item will no longer appear in display mode. (The default setting is enabled.)

Concentrations of the following combustible gases can be converted:

Conversion gas		Conversion from methane (CH ₄) specifications	Conversion from isobutane (HC (i-C ₄ H ₁₀)) specifications	Is conversion possible when restricted?
Methane	CH ₄	-	N	Y
Isobutane	HC (i-C ₄ H ₁₀)	Y	-	Y
Hydrogen	H ₂	Y	Y	Y
Methanol	CH ₃ OH	Y	Y	N
Acetylene	C ₂ H ₂	Y	Y	Y
Ethylene	C ₂ H ₄	Y	Y	Y
Ethane	C ₂ H ₆	Y	N	Y
Ethanol	C ₂ H ₅ OH	Y	Y	N
Propylene	C ₃ H ₆	Y	Y	Y
Acetone	C ₃ H ₆ O	Y	Y	N
Propane	C ₃ H ₈	Y	N	Y
Butadiene	C ₄ H ₆	Y	Y	Y
Cyclopentane	C ₅ H ₁₀	Y	Y	Y
Benzene	C ₆ H ₆	Y	Y	N
N-hexane	n-C ₆ H ₁₄	Y	Y	Y
Toluene	C ₇ H ₈	Y	Y	N
Heptane	n-C ₇ H ₁₆	Y	Y	Y
Xylene	C ₈ H ₁₀	Y	Y	N
N-nonane	n-C ₉ H ₂₀	Y	Y	N
Ethyl acetate	EtAc	Y	Y	N
IPA	IPA	Y	Y	N
MEK	MEK	Y	Y	N
Methyl methacrylate	MMA	Y	Y	N

Conversion gas		Conversion from methane (CH ₄) specifications	Conversion from isobutane (HC (i-C ₄ H ₁₀)) specifications	Is conversion possible when restricted?
Dimethyl ether	DME	Y	Y	N
Methyl isobutyl ketone	MIBK	Y	Y	N
Tetrahydrofuran	THF	Y	Y	N
N-pentane	n-C ₅ H ₁₂	Y	Y	Y



CAUTION

- On models that detect combustible gases, the message [READ GAS LIST IN MANUAL] may be displayed on a screen displayed after turning on the power with the buzzer sounding and lamp flashing. If this screen appears, the alarm can be reset by pressing the RESET button.
- The above screen appears when the combustible gas sensor is placed under the poisoning effects of silicone compounds or halides. If the above screen is displayed, the conversion function can be used only for those gas types marked "Y" in the "Is conversion possible when restricted?" column. To continue to use the conversion function for gas types marked "N", contact RIKEN KEIKI.
- If a gas type indicated as "N" in the "Is conversion possible when restricted?" column in the conversion gas list is selected when the screen above is displayed, the conversion setting will be automatically reset, and the detection target gas (methane or isobutane, as specified at the time of purchase) will be measured.
- Even when using the combustible gas conversion function, do not perform a bump test or gas adjustment using the conversion gas. Bump tests and gas adjustment must always be performed using the detection target gas (methane or isobutane, as specified at the time of purchase).

NOTE

- The concentration display when converted should be treated as approximate.
- The product specifications vary depending on the combustible gas to be measured. Depending on the product specifications, certain gas types may not be converted.
- Even if the combustible conversion gas function is selected, the readings will be affected if other combustible gases are present in the usage environment. However, if hydrogen (H₂) is selected as the conversion gas, the readings will not be affected by gas types indicated as "N" in the "Is conversion possible when restricted?" column in the conversion gas list, even if they are present in the operating environment.
- If the combustible gas conversion function is used, the indication accuracy for the product will not be achieved.

1 Press the DISP button several times on the concentration display screen in normal mode to display the [HC GAS LIST] screen.

2 Press the POWER/ENTER button.
If you do not wish to set, press the DISP button.

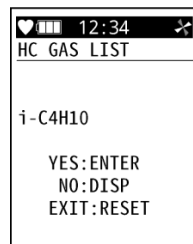

- 3 Press the **▲/AIR** or **SHIFT/▼** button to select the gas type for conversion.

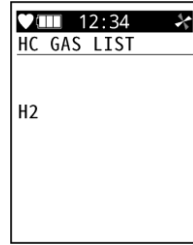

- 4 Press the **POWER/ENTER** button.
Conversion will be performed for the selected gas type. [END] appears, and the display returns to the screen in Step 1.

NOTE

- ▶ To cancel the setting, press the DISP button in Step 4.

6-4-3 Switching to benzene select mode

Switch from normal mode to benzene select mode. Benzene select mode allows benzene to be measured selectively using the dedicated pre-filter tube (CF-8338) and tube holder (GF-284).

NOTE

- ▶ Benzene select mode is available if a VOC (10.0 eV) sensor is installed. The item does not appear in display mode in other cases.
- ▶ [BENZENE SELECT] is not displayed if benzene select is disabled in [Disp mode item] in the configuration program. (The default setting is enabled.)

- 1 Press the **DISP** button several times on the concentration display screen in normal mode to display the **[BENZENE SELECT]** screen.

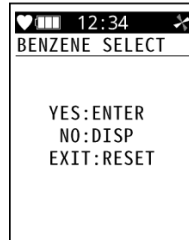

- 2 Press the **POWER/ENTER** button.
If you do not wish to set, press the DISP button.

- 3 Attach the pre-filter tube (CF-8338) and tube holder (GF-284) to the product, then press the **POWER/ENTER** button.

The following operations stop:

- Pump operation
- Data logger interval trend recording function
- Data logger alarm trend recording function

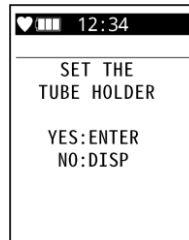

4 Press the POWER/ENTER button.

The pump starts operating, and benzene measurement starts.

The measurement time countdown is displayed.

The time taken for measurement differs depending on the temperature.

For information on the measurement time, see the following list.

The numbers listed below are displayed at the bottom left of the screen.

1	-20.0 to -10.1 °C	135 seconds
2	-10.0 to -0.1 °C	110 seconds
3	0.0 to +9.9 °C	90 seconds
4	+10.0 to +19.9 °C	70 seconds
5	+20.0 to +29.9 °C	45 seconds
6	+30.0 to +50.0 °C	35 seconds

The measurement results are displayed once the countdown ends.

To perform benzene measurement once again, press the POWER/ENTER button to display the [CHANGE TUBE] screen. Replace the pre-filter tube, then press the POWER/ENTER button to proceed to the [START MEASUREMENT] screen in Step 4.

To return to measurement in normal mode, press the DISP button to display the [DISCONNECT TUBE] screen. Pressing the POWER/ENTER button returns the display to the normal mode concentration display screen.

To measure the benzene STEL value, press the RESET button to proceed to the [START STEL MEASUREMENT] screen in Step 5.

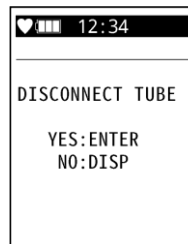
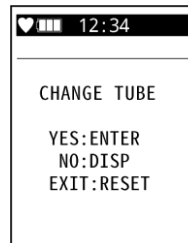
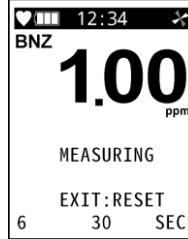
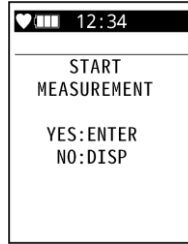

- 5 Press the **POWER/ENTER** button.
STEL value measurement starts.

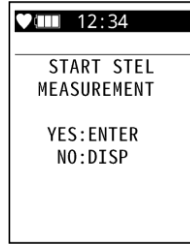

The measurement time countdown is displayed at the bottom of the screen. The measurement time is 900 seconds.

To abort measurement, press the **RESET** button, then press the **POWER/ENTER** button.

Displays measurement results.



To perform STEL measurement again, press the **POWER/ENTER** button to proceed to the [CHANGE TUBE] screen in Step 4.

To return to measurement in normal mode, press the **DISP** button to proceed to the [DISCONNECT TUBE] screen in Step 4.



6-4-4 Volatile organic compound (VOC) conversion gas selection

Volatile organic compound (VOC) concentration is normally displayed as isobutylene (C₄H₈), but this can be displayed converted to a specific pre-registered gas.

For information on volatile organic compound (VOC) conversion gas types, refer to 'TED0284 Volatile organic compound (VOC) conversion gas list' from the product information page on the RIKEN KEIKI website.

NOTE

- ▶ Volatile organic compound (VOC) conversion can be set only if a VOC sensor is installed. The item does not appear in display mode in other cases.
- ▶ If multiple VOC sensors are installed, a setting screen appears for each sensor.
- ▶ The list of gas types displayed will vary depending on the VOC sensor model (10.6 eV/10.0 eV) installed.
- ▶ The list of gas types displayed is as follows:
 - [USER LIST]: List set using the MT-GX-6100 configuration program (up to 30 for each VOC sensor model)
 - [RECENT]: Recently used gas types (up to 7 for each VOC sensor model)
 - List of initials [A] to [Z]: All of the conversion gas types
- ▶ If the PID gas list function is disabled in [Disp mode item] in the configuration program, this setting item will no longer appear in display mode. (The default setting is enabled.)

- 1 **Press the DISP button several times on the concentration display screen in normal mode to display the [SELECT PID LIST] screen.**

[10.6eV] or [10.0eV] will be displayed depending on the VOC sensor model.

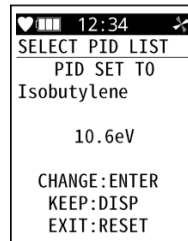

- 2 **Press the POWER/ENTER button.**
If you do not wish to set, press the DISP button.

- 3 **Press the ▲/AIR or SHIFT/▼ button to select the menu to be displayed.**

- 4 **Press the POWER/ENTER button.**
The gas names are displayed.

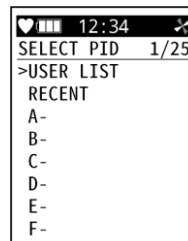

- 5 Press the ▲/AIR or SHIFT/▼ button to select the gas type for conversion.

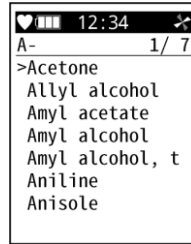

- 6 Press the POWER/ENTER button.
Information is displayed for the selected gas type.

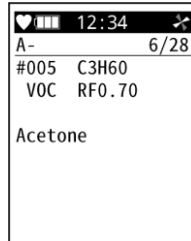

- 7 Press the POWER/ENTER button.
Once setting is complete, [END] appears, and the display returns to the screen in Step 1.

NOTE

- ▶ Hold down the ▲/AIR or SHIFT/▼ button on the gas name list to move 10 items up or down at a time.
 - ▶ To cancel the setting, press the DISP button in Step 6.
-

6-4-5 Setting the user ID

Set the user ID.

The user ID is used to identify individual users.

- 1 Press the DISP button several times on the concentration display screen in normal mode to display the [USER ID] screen.

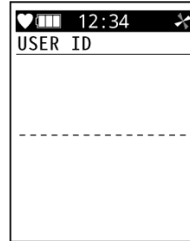

- 2 Press the POWER/ENTER button.
If you do not wish to set, press the DISP button.

- 3 Press the ▲/AIR or SHIFT/▼ button to select a user ID.

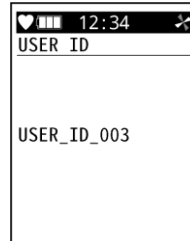

- 4 Press the POWER/ENTER button.

The user ID selected is set.

[END] appears, and the display returns to the screen in Step 1.

NOTE

- ▶ User IDs can be set from USER_ID_001 to USER_ID_128.
- ▶ Hold down the ▲/AIR or SHIFT/▼ button on the user ID list to move 10 items up or down at a time.
- ▶ To cancel the setting, press the DISP button in Step 4.
- ▶ The separately sold data logger management program or configuration program is required to edit user IDs.
- ▶ If the user ID selection function is disabled in [Disp mode item] in the configuration program, this setting item will no longer appear in display mode. (The default setting is enabled.)

6-4-6 Setting the station ID

Set the station ID.

The station ID is used to identify measurement points.

- 1 Press the **DISP** button several times on the concentration display screen in normal mode to display the **[STATION ID]** screen.

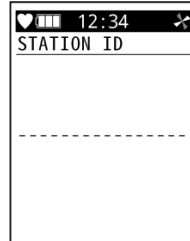

- 2 Press the **POWER/ENTER** button.
If you do not wish to set, press the **DISP** button.

- 3 Press the **▲/AIR** or **SHIFT/▼** button to select a station ID.

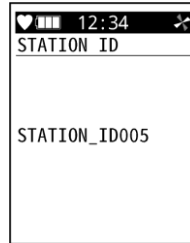

- 4 Press the **POWER/ENTER** button.
The station ID selected is set.
[END] appears, and the display returns to the screen in Step 1.

NOTE

- ▶ Station IDs can be set from STATION_ID_001 to STATION_ID_128.
- ▶ Hold down the **▲/AIR** or **SHIFT/▼** button on the station ID list to move 10 items up or down at a time.
- ▶ To cancel the setting, press the **DISP** button in Step 4.
- ▶ The separately sold data logger management program or configuration program is required to edit station IDs.
- ▶ If the station ID selection function is disabled in [Disp mode item] in the configuration program, this setting item will no longer appear in display mode. (The default setting is enabled.)

6-4-7 LCD inversion setting

This setting inverts the LCD display by 180 degrees.

Three settings are available: [AUTO] to invert the display by 180 degrees according to the orientation of the product; [ON] to invert the display by 180 degrees regardless of product orientation; and [OFF] to disable inversion regardless of product orientation.

NOTE

- ▶ The default setting is [OFF].
- ▶ If [OFF] is selected, [LOCK] is displayed (lit) in the upper right of the screen, as shown in the figure on the right.
- ▶ If [ON] or [AUTO] is selected, the display orientation can be locked by holding down the DISP button during use. When locked, [LOCK] is displayed (blinking) in the upper right of the screen, as shown in the figure on the right.
- ▶ The LCD inversion setting is retained even when the power is turned off. However, if the display orientation is locked by holding down the DISP button, this setting will be reset when the power is turned off.
- ▶ If the LCD inversion setting is disabled in [Disp mode item] in the configuration program, this setting item will no longer appear in display mode. (The default setting is enabled.)

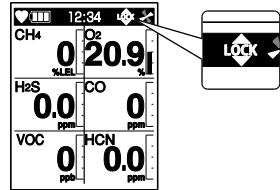

1 Press the DISP button several times on the concentration display screen in normal mode to display the [INVERSION SELECT] screen.

2 Press the POWER/ENTER button.
If you do not wish to set, press the DISP button.

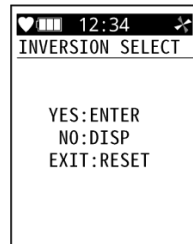

3 Press the ▲/AIR or SHIFT/▼ button to select [AUTO], [ON], or [OFF].

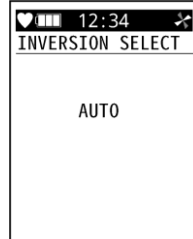

4 Press the POWER/ENTER button.

LCD inversion is set.
[END] appears, and the display returns to the screen in Step 1.

NOTE

- ▶ To cancel the setting, press the DISP button in Step 4.

6-4-8 LCD background setting

Inverts black and white of the screen background.
Set to [ON] to display white text against a black background.

NOTE

- ▶ An example screen is shown on the right with black and white of the background inverted.
- ▶ The default setting is [OFF].
- ▶ The Bluetooth device connection setting (on or off) is retained even when the power is turned off.
- ▶ If the LCD background setting is disabled in [Disp mode item] in the configuration program, this setting item will no longer appear in display mode. (The default setting is enabled.)

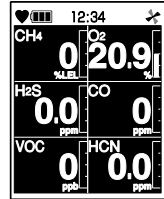

1 Press the DISP button several times on the concentration display screen in normal mode to display the [LCD BACKGROUND] screen.

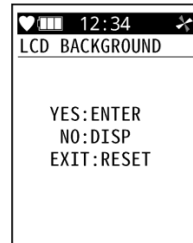

2 Press the POWER/ENTER button.
If you do not wish to set, press the DISP button.

3 Press the ▲/AIR or SHIFT/▼ button to select [ON] or [OFF].

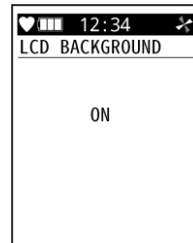

4 Press the POWER/ENTER button.

The LCD background is set.
[END] appears, and the display returns to the screen in Step 1.

NOTE

- ▶ To cancel the setting, press the DISP button in Step 4.

6-4-9 Peak bar display setting

Set the blinking [ON] or [OFF] for the peak value in the bar display on the right of the concentration display screen.

Set to [ON] to make the peak value blink.

NOTE

- ▶ The default setting is [OFF].
- ▶ The peak bar display setting (on or off) is retained even when the power is turned off.
- ▶ If the peak bar display is disabled in [Disp mode item] in the configuration program, this setting item will no longer appear in display mode. (The default setting is enabled.)

1 Press the DISP button several times on the concentration display screen in normal mode to display the [PEAK BAR] screen.

2 Press the POWER/ENTER button.
If you do not wish to set, press the DISP button.

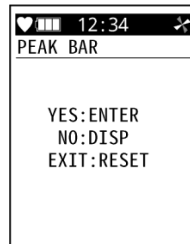

3 Press the ▲/AIR or SHIFT/▼ button to select [ON] or [OFF].



4 Press the POWER/ENTER button.

The peak bar display is set.
[END] appears, and the display returns to the screen in Step 1.

NOTE

- ▶ To cancel the setting, press the DISP button in Step 4.

6-4-10 Measurement gas scroll setting

Set whether the concentration display screen shows multiple gases simultaneously or displays a single gas. Select one of the following. The default setting is [DISPLAY ALL].

- [DISPLAY ALL]: Displays all gas types on a single screen.
- [SCROLL AUTO]: Scrolls each gas in sequence automatically.
- [SCROLL MANUAL]: Scrolls each gas in sequence manually. Pressing the POWER/ENTER button cycles through the gas types.

NOTE

- ▶ The default setting is [DISPLAY ALL].
- ▶ The measurement gas scroll setting is reset to the default setting when the power is turned off.
- ▶ If the measurement gas scroll setting is disabled in [Disp mode item] in the configuration program, this setting item will no longer appear in display mode. (The default setting is enabled.)

1 Press the DISP button several times on the concentration display screen in normal mode to display the [GAS DISP] screen.

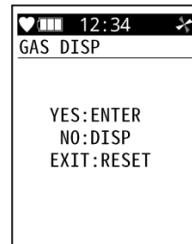

2 Press the POWER/ENTER button.
If you do not wish to set, press the DISP button.

3 Press the ▲/AIR or SHIFT/▼ button to select [DISPLAY ALL], [SCROLL AUTO], or [SCROLL MANUAL].

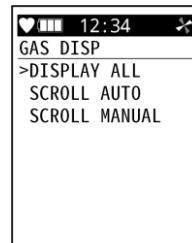

4 Press the POWER/ENTER button.

The measurement gas scroll is set.
[END] appears, and the display returns to the screen in Step 1.

NOTE

- ▶ To cancel the setting, press the DISP button in Step 4.

6-4-11 Setting a Bluetooth device connection

Set the connection to a Bluetooth device when the Bluetooth function is enabled.

Setting this item to [ON] allows communication with a smartphone that has the dedicated app installed.

NOTE

- ▶ The default setting is [OFF].
- ▶ Whether the Bluetooth function is enabled or disabled is specified at the time of ordering.
- ▶ The Bluetooth device connection setting is retained even when the power is turned off.
- ▶ RK Link (the dedicated app) can be downloaded free of charge from Google Play or App Store.
- ▶ By default, the Bluetooth function automatically turns [OFF] if no communication occurs for five minutes after the function is turned [ON]. This setting can be altered using the separately sold data logger management program or configuration program.
- ▶ If the Bluetooth connection on/off setting is disabled in [Disp mode item] in the configuration program, this setting item will no longer appear in display mode. (The default setting is enabled.)

- 1 **Press the DISP button several times on the measurement mode screen to display the [BLUETOOTH] screen.**



- 2 **Press the POWER/ENTER button.**
If you do not wish to set, press the DISP button.

- 3 **Press the ▲/AIR or RESET/▼ button to select [ON] or [OFF].**



- 4 **Press the POWER/ENTER button.**

The Bluetooth device connection is set.

[SETTING] appears, followed by [END], after which the display returns to the screen in Step 1.

NOTE

- ▶ To cancel the setting, press the DISP button in Step 4.

6-4-12 Setting the buzzer volume

Select the buzzer volume setting.
The volume can be selected as [HIGH] or [LOW].

NOTE

- ▶ The default setting is [HIGH].
- ▶ The buzzer volume setting is retained even when the power is turned off.
- ▶ If the buzzer volume adjustment function is disabled in [Disp mode item] in the configuration program, this setting item will no longer appear in display mode. (The default setting is enabled.)

1 Press the DISP button several times on the concentration display screen in normal mode to display the [BUZZER VOLUME] screen.

2 Press the POWER/ENTER button.
If you do not wish to set, press the DISP button.

3 Press the ▲/AIR or SHIFT/▼ button to select [HIGH] or [LOW].

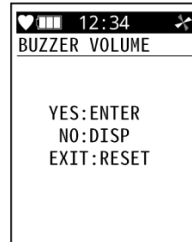

4 Press the POWER/ENTER button.

The buzzer volume is set.
[END] appears, and the display returns to the screen in Step 1.

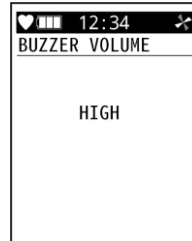

NOTE

- ▶ To cancel the setting, press the DISP button in Step 4.

6-4-13 Switching display language to Japanese (Japan Ex model)

Returns the display language to Japanese.

NOTE

- ▶ This can be set if a language other than Japanese is set with the Japan Ex model. The item does not appear in display mode in other cases.
- ▶ The display language setting is retained even when the power is turned off.
- ▶ The display language should be set using [LANGUAGE] in user mode. (See '7-5-4 Setting the display language'.)
- ▶ If the return to Japanese function is disabled in [Disp mode item] in the configuration program, this setting item will no longer appear in display mode. (The default setting is enabled.)

1 Press the DISP button several times on the concentration display screen in normal mode to display the [言語] (LANGUAGE) screen.

2 Press the POWER/ENTER button.
If you do not wish to set, press the DISP button.

3 Press the POWER/ENTER button.

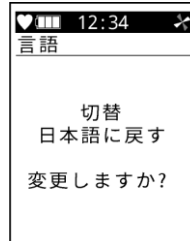
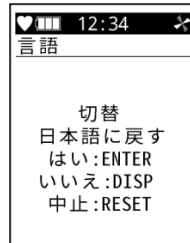

The display switches to Japanese.
[終了] (END) appears, and the display returns to the screen in Step 1.

NOTE

- ▶ To cancel the setting, press the DISP button in Step 3.

6-4-14 Switching display language to English (ATEX/IECEx model)

Returns the display language to English.

NOTE

- ▶ This can be set if a language other than English is set with the ATEX/IECEx model. The item does not appear in display mode in other cases.
- ▶ The display language setting is retained even when the power is turned off.
- ▶ The display language should be set using [LANGUAGE] in user mode. (See '7-5-4 Setting the display language'.)
- ▶ If the return to English function is disabled in [Disp mode item] in the configuration program, this setting item will no longer appear in display mode. (The default setting is enabled.)

1 Press the DISP button several times on the concentration display screen in normal mode to display the [CHANGE TO ENGLISH] screen.

2 Press the POWER/ENTER button.
If you do not wish to set, press the DISP button.

3 Press the POWER/ENTER button.

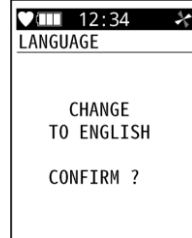
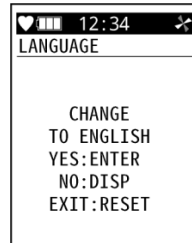

The display switches to English.
[END] appears and the display returns to the screen in Step 1.



NOTE





- ▶ To cancel the setting, press the DISP button in Step 2.

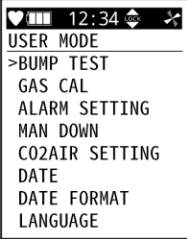
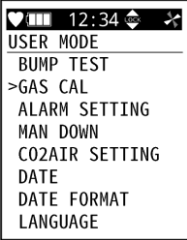

7

Settings (User Mode)

7-1 User mode display items

LCD display	Description	Reference
<p>[BUMP TEST]</p>  <p>The screenshot shows the LCD display with a status bar at the top containing a heart icon, battery level, time (12:34), and signal strength. Below the status bar, the text reads: 'USER MODE', '>BUMP TEST', 'GAS CAL', 'ALARM SETTING', 'MAN DOWN', 'CO2AIR SETTING', 'DATE', 'DATE FORMAT', and 'LANGUAGE'.</p>	<p>Performs a bump test.</p>	<p>8-3 Performing bump tests</p>
<p>[GAS CAL]</p>  <p>The screenshot shows the LCD display with a status bar at the top containing a heart icon, battery level, time (12:34), and signal strength. Below the status bar, the text reads: 'USER MODE', 'BUMP TEST', '>GAS CAL', 'ALARM SETTING', 'MAN DOWN', 'CO2AIR SETTING', 'DATE', 'DATE FORMAT', and 'LANGUAGE'.</p>	<p>Performs fresh air adjustment, CO₂ zero adjustment, and span adjustment. CO₂ zero adjustment is performed if a carbon dioxide sensor is installed.</p>	<p>8-2 Performing gas adjustment</p>
<p>[ALARM SETTING]</p>  <p>The screenshot shows the LCD display with a status bar at the top containing a heart icon, battery level, time (12:34), and signal strength. Below the status bar, the text reads: 'USER MODE', 'BUMP TEST', 'GAS CAL', '>ALARM SETTING', 'MAN DOWN', 'CO2AIR SETTING', 'DATE', 'DATE FORMAT', and 'LANGUAGE'.</p>	<p>Set the gas alarm setpoints, alarm type, and alarm pattern for each sensor. Alarm setpoints can also be returned to their default settings.</p>	<p>7-3 Gas alarm settings</p>

LCD display	Description	Reference
<p>[MAN DOWN]</p>  <p>USER MODE BUMP TEST GAS CAL ALARM SETTING >MAN DOWN CO2AIR SETTING DATE DATE FORMAT LANGUAGE</p>	<p>Set whether to enable or disable the man down alarm and panic alarm, and set the man down alarm times.</p>	<p>7-4 Man down alarm and panic alarm settings</p>
<p>[CO2AIR SETTING]</p>  <p>USER MODE GAS CAL ALARM SETTING MAN DOWN >CO2AIR SETTING DATE DATE FORMAT LANGUAGE VERSION</p>	<p>Set whether to perform fresh air adjustment for the carbon dioxide sensor during fresh air adjustment. This is displayed if a carbon dioxide sensor is installed.</p>	<p>7-5-1 Enabling/disabling CO₂ fresh air adjustment</p>
<p>[DATE]</p>  <p>USER MODE ALARM SETTING MAN DOWN CO2AIR SETTING >DATE DATE FORMAT LANGUAGE VERSION START MEASURE</p>	<p>Set the internal clock date (year, month, day) and time (hours and minutes).</p>	<p>7-5-2 Setting the date and time</p>
<p>[DATE FORMAT]</p>  <p>USER MODE ALARM SETTING MAN DOWN CO2AIR SETTING DATE >DATE FORMAT LANGUAGE VERSION START MEASURE</p>	<p>Set the date display format.</p>	<p>7-5-3 Setting the date format</p>

LCD display	Description	Reference
<p>[LANGUAGE]</p> 	Set the screen display language.	7-5-4 Setting the display language
<p>[VERSION]</p> 	Displays the version information for the modules mounted in the product.	7-5-5 Displaying version information
<p>[START MEASURE]</p> 	The screen shifts in the same way as when pressing the POWER/ENTER button with the power off.	-

7-2 Switching to user mode

- 1 **Turn off the power.**
Hold down the POWER/ENTER button.
- 2 **Press POWER/ENTER and ▲/AIR buttons simultaneously.**
- 3 **Release the buttons when the buzzer blips once.**
The power turns on and the [MODE SELECT] screen is displayed.
- 4 **Press the ▲/AIR or SHIFT/▼ button to select [USER MODE].**

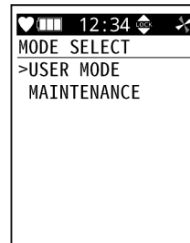

- 5 **Press the POWER/ENTER button.**
The user mode menu appears.

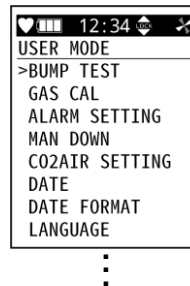

- 6 **Press the ▲/AIR or SHIFT/▼ button to select the item to be set.**

NOTE

- ▶ A password input screen is displayed when you press the POWER/ENTER button in Step5 if the user mode password setting is enabled. Press the ▲/AIR or SHIFT/▼ button to select a number, then press the POWER/ENTER button to confirm. The user mode menu is displayed once the (four-digit) password has been correctly entered. The default password is 0000. Note that the password can be changed in the configuration program.
- ▶ [ERROR] will appear if an incorrect password is entered. If [ERROR] appears, the power must be turned off and then back on again.

<Switching from user mode to measurement mode>

- 1 Press the ▲/AIR or SHIFT/▼ button in user mode, select [START MEASURE], then press the POWER/ENTER button.

The product operates in the same way as when turning on the power and enters measurement mode.

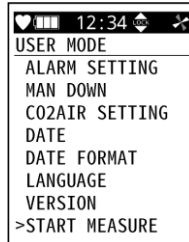

7-3 Gas alarm settings

7-3-1 Setting alarm setpoints

Alarm setpoints can be set individually for each sensor. Alarm setpoints can be set in increments corresponding to the resolution.

Sensor	Detection target gas	Resolution	Setting range lower limit (): recommended range	Setting range upper limit (): recommended range
NCR-6309	Methane (CH ₄) Isobutane (HC (i-C ₄ H ₁₀))	1 %LEL	1 %LEL (10 %LEL or more)	60 %LEL
ESR-X13P	Oxygen (O ₂)	0.1 %	0.1 % (19.5 % or less)	25.0 % (23.5 % or more)
ESR-A13i/ ESR-A1DP	Hydrogen sulfide (H ₂ S)	0.1 ppm	0.5 ppm (1.0 ppm or more)	200.0 ppm
ESR-A13P/ ESR-A1DP/ ESR-A1CP	Carbon monoxide (CO)	1 ppm	12 ppm (25 ppm or more)	2,000 ppm
ESS-03DH	Sulfur dioxide (SO ₂)	0.05 ppm	0.00 ppm (2.00 ppm or more)	99.90 ppm
ESS-03DH	Nitrogen dioxide (NO ₂)	0.05 ppm	0.00 ppm (3.00 ppm or more)	20.00 ppm
ESS-03DH	Hydrogen cyanide (HCN)	0.1 ppm	0.3 ppm (5.0 ppm or more)	15.0 ppm
ESS-B332	Ammonia (NH ₃)	0.5 ppm	0.0 ppm (25.0 ppm or more)	400.0 ppm
ESS-B335	Chlorine (Cl ₂)	0.05 ppm	0.00 ppm (0.50 ppm or more)	10.00 ppm
ESS-03DH	Phosphine (PH ₃)	0.01 ppm	0.00 ppm (0.30 ppm or more)	20.00 ppm
DES-3311-2	Isobutane (HC (i-C ₄ H ₁₀))	1 %LEL/0.5 vol%	0 %LEL (10 %LEL or more)	30.0 vol% (60 %LEL or less)
DES-3311-3	Methane (CH ₄)	1 %LEL/0.5 vol%	0 %LEL (10 %LEL or more)	100.0 vol% (60 %LEL or less)
DES-3311-1	Carbon dioxide (CO ₂ , vol%)	0.02 vol%	0.00 vol% (0.50 vol% or more)	10.00 vol% (5.00 vol% or less)
DES-3311-4	Carbon dioxide (CO ₂ , ppm)	20 ppm	0 ppm (1,000 ppm or more)	10,000 ppm
PIS-001A	Volatile organic compounds (VOC, 10.6 eV, ppm)	1 ppb (0 – 4,000 ppb) 10 ppb (4,000 – 40,000 ppb)	0 ppb (5,000 ppm or more)	40,000 ppb
PIS-002A	Volatile organic compounds (VOC, 10.6 eV, ppm)	0.1 ppm (0 – 400.0 ppm) 1 ppm (400 – 4,000 ppm)	0.0 ppm (400 ppm or more)	4,000 ppm
PIS-003	Volatile organic compounds (VOC, 10.0 eV, ppm)	0.01 ppm (0 – 10.00 ppm) 0.1 ppm (10.0 – 100.0 ppm)	0.00 ppm (5.00 ppm or more)	100.0 ppm

NOTE

- ▶ Set the alarm setpoints as follows: First alarm \leq Second alarm \leq Third alarm (for oxygen: Second alarm \leq First alarm \leq Third alarm).
- ▶ Use the product with the alarms set to within a range compatible with product performance. Alarm setpoints below the recommended range may result in false alarms.
- ▶ The [STEL] and [TWA] setting screens will not be displayed when "-" is indicated in the STEL and TWA alarm setpoint columns. (See '4-2 Gas alarm setpoints'.)
- ▶ Hold down the \blacktriangle /AIR or SHIFT/ \blacktriangledown button (for less than seven seconds) when setting an alarm setpoint to change the value in increments corresponding to 10 times the resolution. In addition, hold down the button for seven seconds or more to change the value in increments corresponding to more than 10 times the resolution.
- ▶ Press the DISP button when setting an alarm setpoint to return to the previous screen.
- ▶ To return to the user mode menu, select [ESCAPE], then press the POWER/ENTER button.

- 1 Press the \blacktriangle /AIR or SHIFT/ \blacktriangledown button in the user mode menu to select [ALARM SETTING], then press the POWER/ENTER button.

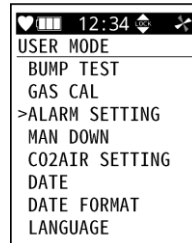

- 2 Check to confirm that [ALARM POINTS] is selected, then press the POWER/ENTER button.

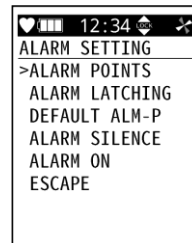

- 3 Press the \blacktriangle /AIR or SHIFT/ \blacktriangledown button to select the sensor, then press the POWER/ENTER button.

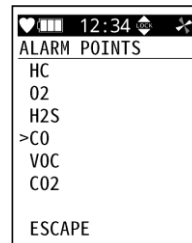

- 4 Press the ▲/AIR or SHIFT/▼ button to select the alarm setpoint to be set, then press the POWER/ENTER button.

Press the ▲/AIR or SHIFT/▼ button to change the value in increments corresponding to the resolution.

- 5 Press the ▲/AIR or SHIFT/▼ button to set the value for the alarm setpoint, then press the POWER/ENTER button.

[END] appears, and the display returns to the screen in Step 4.

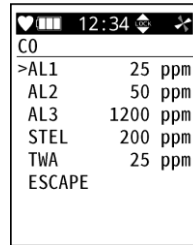

The screenshot shows a handheld device screen with a status bar at the top containing a heart icon, battery level, time 12:34, and signal strength. Below the status bar, the text 'CO' is displayed. A list of settings follows: '>AL1 25 ppm', 'AL2 50 ppm', 'AL3 1200 ppm', 'STEL 200 ppm', 'TWA 25 ppm', and 'ESCAPE'.

Setting	Value	Unit
>AL1	25	ppm
AL2	50	ppm
AL3	1200	ppm
STEL	200	ppm
TWA	25	ppm
ESCAPE		

7-3-2 Setting alarm pattern

Set the alarm pattern.

This can be set to [LATCHING] or [SELF RESET].

NOTE

- ▶ The default setting is [LATCHING].
- ▶ If self-latching is selected, the alarm is reset when the RESET button is pressed after the gas concentration has returned to normal.
- ▶ If auto-reset is selected, the alarm is reset automatically once the gas concentration has returned to normal.

- 1 Press the **▲/AIR** or **SHIFT/▼** button in the user mode menu to select [ALARM SETTING], then press the **POWER/ENTER** button.

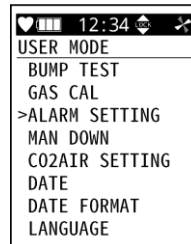

- 2 Press the **▲/AIR** or **SHIFT/▼** button to select [ALARM LATCHING], then press the **POWER/ENTER** button.

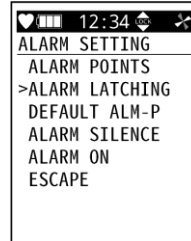

- 3 Press the **▲/AIR** or **SHIFT/▼** button to select [LATCHING] or [SELF RESET].



- 4 Press the **POWER/ENTER** button.

The alarm pattern is set.
[END] appears, and the display returns to the screen in Step 2.

NOTE

- ▶ To cancel the setting, press the DISP button in Step 3.
- ▶ To return to the user mode menu, select [ESCAPE] in the alarm setting menu, then press the **POWER/ENTER** button.

7-3-3 Resetting alarm setpoints

This restores alarm setpoints to their default settings.

NOTE

- ▶ This item does not appear in user mode if the sensors installed are not the default sensors.
- ▶ For information on alarm setpoint default settings, see '4-2 Gas alarm setpoints'.

- 1 Press the ▲/AIR or SHIFT/▼ button in the user mode menu to select [ALARM SETTING], then press the POWER/ENTER button.

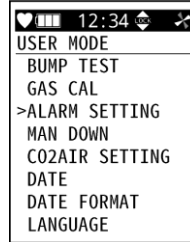

- 2 Press the ▲/AIR or SHIFT/▼ button to select [DEFAULT ALM-P], then press the POWER/ENTER button.

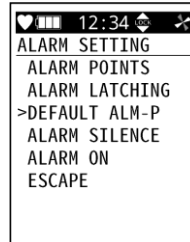

- 3 Press the POWER/ENTER button.
To cancel resetting, press the DISP button.
The alarm setpoints are reset once [PASS] is displayed.
[END] appears, and the display returns to the screen in Step 2.

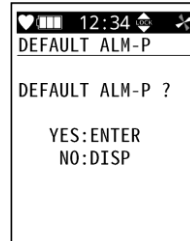

NOTE

- ▶ To return to the user mode menu, select [ESCAPE] in the alarm setting menu, then press the POWER/ENTER button.

7-3-4 Alarm silence setting

Set whether to enable or disable the function (alarm silence function) for stopping the gas alarm sound by pressing a button when a gas alarm is triggered in normal mode.

NOTE

- ▶ The default setting is [OFF].
- ▶ If the alarm silence setting is enabled, the alarm sound can be stopped by pressing the RESET button when a gas alarm is triggered in normal mode. However, the LED and vibration functions will continue to operate.
- ▶ The gas alarm will sound once again if another gas alarm is triggered after pressing the RESET button to silence the first alarm.
- ▶ This setting applies only to the gas alarm sound in normal mode. For information on gas alarm patterns in leak check mode, see '7-3-5 Leak alarm silence setting'.

- 1 Press the ▲/AIR or SHIFT/▼ button in the user mode menu to select [ALARM SETTING], then press the POWER/ENTER button.

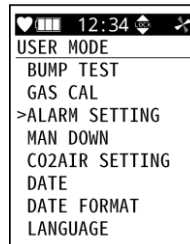

- 2 Press the ▲/AIR or SHIFT/▼ button to select [ALARM SILENCE], then press the POWER/ENTER button.

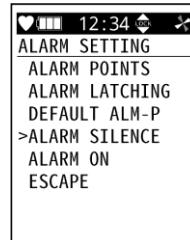

- 3 Press the POWER/ENTER button.
 To cancel the setting, press the DISP button.

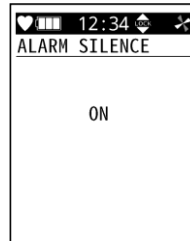

The alarm silence function is set.
 [END] appears, and the display returns to the screen in Step 2.

NOTE

- ▶ To return to the user mode menu, select [ESCAPE] in the alarm setting menu, then press the POWER/ENTER button.

7-3-5 Leak alarm silence setting

Set whether to enable or disable the function (alarm silence function) to prevent alarm operation when a gas alarm is triggered in leak check mode.

NOTE

- ▶ The default setting is [OFF].
- ▶ If the leak alarm silence setting is enabled, the buzzer will not sound when a gas alarm is triggered in leak check mode. (With the default setting of [OFF], the buzzer will sound when a gas alarm is triggered.)
- ▶ This setting applies only to the gas alarm operation in leak check mode. For information on gas alarm patterns in normal mode, see '7-3-4 Alarm silence setting'.

- 1 Press the **▲/AIR** or **SHIFT/▼** button in the user mode menu to select **[ALARM SETTING]**, then press the **POWER/ENTER** button.

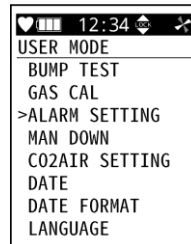

- 2 Press the **▲/AIR** or **SHIFT/▼** button to select **[LEAK SILENCE]**, then press the **POWER/ENTER** button.

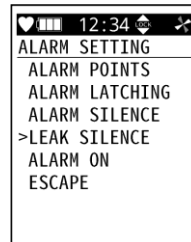

- 3 Press the **▲/AIR** or **SHIFT/▼** button to select **[ON]** or **[OFF]**.

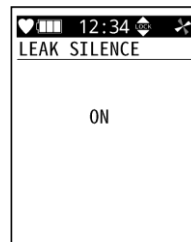

- 4 Press the **POWER/ENTER** button.
The leak alarm silence function is set.
[END] appears, and the display returns to the screen in Step 2.

NOTE

- ▶ To cancel the setting, press the DISP button in Step 4.
- ▶ To return to the user mode menu, select [ESCAPE] in the alarm setting menu, then press the POWER/ENTER button.

7-3-6 Disabling the gas alarm function

Set whether to enable or disable the gas alarm function.

Gas alarms will not operate if the gas alarm function is set to [OFF]. The [NO ALM] icon is also displayed at the top of the screen.

NOTE

- ▶ The default setting is [ON].
- ▶ Fault alarms operate regardless of the gas alarm function setting.

- 1 Press the ▲/AIR or SHIFT/▼ button in the user mode menu to select [ALARM SETTING], then press the POWER/ENTER button.

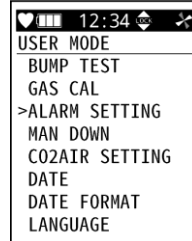

- 2 Press the ▲/AIR or SHIFT/▼ button to select [ALARM ON], then press the POWER/ENTER button.

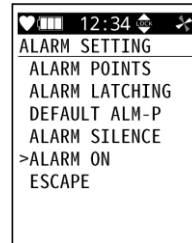

- 3 Press the ▲/AIR or SHIFT/▼ button to select [ON] or [OFF].

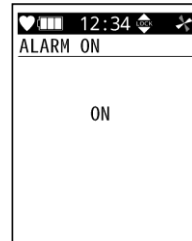

- 4 Press the POWER/ENTER button.
The alarm function is set.
[END] appears, and the display returns to the screen in Step 2.

NOTE

- ▶ To cancel the setting, press the DISP button in Step 4.
- ▶ To return to the user mode menu, select [ESCAPE] in the alarm setting menu, then press the POWER/ENTER button.
- ▶ Fault alarms operate even if the gas alarm function is disabled.

7-4 Man down alarm and panic alarm settings

7-4-1 Enabling/disabling the man down alarm

Set whether to enable or disable the man down alarm function.

If this is set to [ON], the man down alarm will be triggered if no movement is detected within the time period set for [MAN DOWN TIME]. For more information on the man down alarm, see '4-5 Man down alarm'.

NOTE

- ▶ The default setting is [OFF].

- 1 Press the ▲/AIR or SHIFT/▼ button in the user mode menu to select [MAN DOWN], then press the POWER/ENTER button.

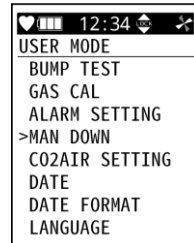

- 2 Press the ▲/AIR or SHIFT/▼ button to select [MAN DOWN], then press the POWER/ENTER button.

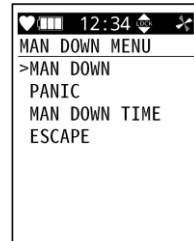

- 3 Press the ▲/AIR or SHIFT/▼ button to select [ON] or [OFF].

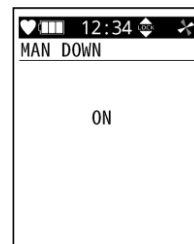

- 4 Press the POWER/ENTER button.
The man down alarm function is set.
[END] appears, and the display returns to the screen in Step 2.

NOTE

- ▶ To cancel the setting, press the DISP button in Step 3.
- ▶ To return to the user mode menu, select [ESCAPE] in the man down menu, then press the POWER/ENTER button.

7-4-2 Enabling/disabling the panic alarm

Set whether to enable or disable the panic alarm function.

If this is set to [ON], the user can manually trigger an alarm by holding down the PANIC button. For more information on the panic alarm, see '4-6 Panic alarm'.

NOTE

- ▶ The default setting is [OFF].

- 1 Press the ▲/AIR or SHIFT/▼ button in the user mode menu to select [MAN DOWN], then press the POWER/ENTER button.

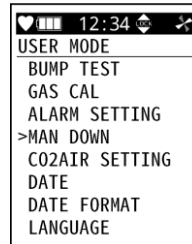

- 2 Press the ▲/AIR or SHIFT/▼ button to select [PANIC], then press the POWER/ENTER button.

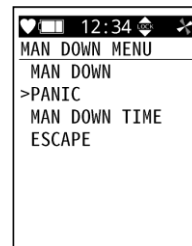

- 3 Press the ▲/AIR or SHIFT/▼ button to select [ON] or [OFF].

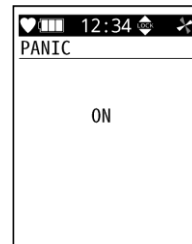

- 4 Press the POWER/ENTER button.
The panic alarm function is set.
[END] appears, and the display returns to the screen in Step 2.

NOTE

- ▶ To cancel the setting, press the DISP button in Step 3.
- ▶ To return to the user mode menu, select [ESCAPE] in the man down menu, then press the POWER/ENTER button.

7-4-3 Setting the man down alarm times

Set the times until a man down alarm is triggered.

The times can be set individually for the prealarm 1, prealarm 2, and main alarm.

For more information on the man down alarm, see '4-5 Man down alarm'.

NOTE

- ▶ The default settings are [60 SEC] for prealarm 1, [75 SEC] for prealarm 2, and [90 SEC] for the main alarm.
- ▶ The time for each alarm can be set in the range 10 s to 120 s.
- ▶ Set the times so that Prealarm 1 ≤ Prealarm 2 ≤ Main alarm.

- 1 Press the ▲/AIR or SHIFT/▼ button in the user mode menu to select [MAN DOWN], then press the POWER/ENTER button.

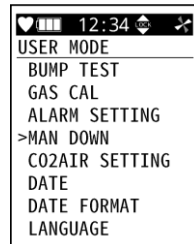

- 2 Press the ▲/AIR or SHIFT/▼ button to select [MAN DOWN TIME], then press the POWER/ENTER button.

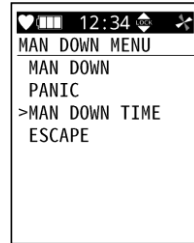

- 3 Press the ▲/AIR or SHIFT/▼ button to select the time for prealarm 1, then press the POWER/ENTER button.

The times are displayed in the order prealarm 2 followed by the main alarm.

Set the time in the same way as for prealarm 1.

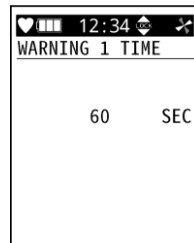

- 4 Repeat Step 2.

After setting the time for the main alarm, press the POWER/ENTER button. [END] appears, and the display returns to the screen in Step 1.

NOTE

- ▶ To cancel the setting, press the DISP button in Step 3.
- ▶ To return to the user mode menu, select [ESCAPE] in the man down menu, then press the POWER/ENTER button.

7-5 Other user mode settings

7-5-1 Enabling/disabling CO₂ fresh air adjustment

Set whether to perform fresh air adjustment for the carbon dioxide sensor during fresh air adjustment. If this is set to [ON], fresh air adjustment for the carbon dioxide sensor is performed during fresh air adjustment.

NOTE

- ▶ The default setting is [OFF].
- ▶ This can be set only if a carbon dioxide sensor is installed. The item does not appear in user mode in other cases.
- ▶ When the CO₂ fresh air adjustment setting is enabled and fresh air adjustment is performed, the carbon dioxide sensor will be automatically set with a carbon dioxide concentration of 400 ppm for the air drawn in regardless of the actual carbon dioxide concentration. Note that this function is an auxiliary function to simplify carbon dioxide sensor adjustment, and the results do not satisfy the normal product specifications.
To adjust the carbon dioxide sensor to zero, perform CO₂ zero adjustment. (See '8-2-3 Performing CO₂ zero adjustment'.)
- ▶ Do not enable the CO₂ fresh air adjustment setting if a VOC sensor is installed. Correct adjustment will not be possible due to the carbon dioxide (CO₂) generated by the activated carbon filter CF-8350.

- 1 Press the **▲/AIR** or **SHIFT/▼** button in the user mode menu to select **[CO2AIR SETTING]**, then press the **POWER/ENTER** button.

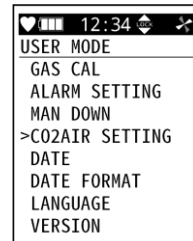

- 2 Press the **▲/AIR** or **SHIFT/▼** button to select **[ON]** or **[OFF]**.

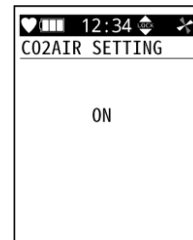

- 3 Press the **POWER/ENTER** button.
Whether to perform fresh air adjustment for the carbon dioxide sensor is set.
[END] appears, and the display returns to the screen in Step 1.

NOTE

- ▶ To cancel the setting, press the DISP button in Step 3.

7-5-2 Setting the date and time

Set the internal clock date (year, month, day) and time (hours and minutes).

Set the date and time in the sequence month → day → year → hours → minutes.

- 1 Press the ▲/AIR or SHIFT/▼ button in the user mode menu to select [DATE], then press the POWER/ENTER button.

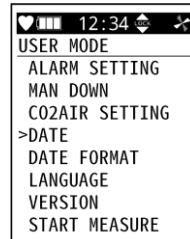

- 2 Press the ▲/AIR or SHIFT/▼ button to set an item of the date and time, then press the POWER/ENTER button.

The item currently selected blinks.

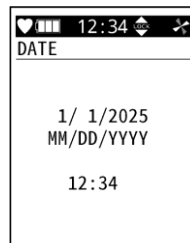

- 3 Repeat Step 2.

After setting the minutes for the time, press the POWER/ENTER button. [END] appears, and the display returns to the screen in Step 1.

NOTE

- ▶ To cancel the setting, press the DISP button in Step 2.
- ▶ Press the DISP button when setting the date (year, month, or day) or time (hours or minutes) to return to the previous screen.
- ▶ Pressing the DISP button when setting the month for the date returns the display to the user mode menu.

7-5-3 Setting the date format

Set the date display format.

The format can be selected from [YYYY/MM/DD], [MM/DD/YYYY], and [DD/MM/YYYY].

NOTE

- ▶ The default setting is [MM/DD/YYYY].

- 1 Press the **▲/AIR** or **SHIFT/▼** button in the user mode menu to select **[DATE FORMAT]**, then press the **POWER/ENTER** button.

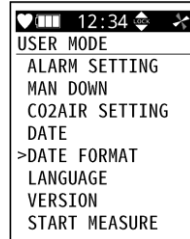

- 2 Press the **▲/AIR** or **SHIFT/▼** button to select the format, then press the **POWER/ENTER** button.

The date format is set.

[END] appears, and the display returns to the screen in Step 1.

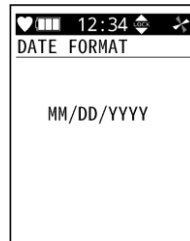

NOTE

- ▶ To cancel the setting, press the DISP button in Step 2.

7-5-4 Setting the display language

Set the screen display language. The following languages are available:

- [ENGLISH]
- [JAPANESE]
- [ITALIAN]
- [SPANISH]
- [GERMAN]
- [FRENCH]
- [PORTUGUESE]
- [RUSSIAN]
- [KOREAN]
- [CHINESE(SC)] (simplified Chinese)
- [CHINESE(TC)] (traditional Chinese)
- [VIETNAMESE]
- [POLISH]
- [TURKISH]
- [SLOVAK]
- [CZECH]

NOTE

- ▶ The default setting is [JAPANESE] for the Japan Ex model. The default setting is [ENGLISH] for the ATEX/IECEX model.

- 1 Press the **▲/AIR** or **SHIFT/▼** button in the user mode menu to select [LANGUAGE], then press the **POWER/ENTER** button.

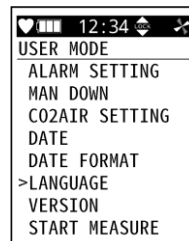

- 2 Press the **▲/AIR** or **SHIFT/▼** button to select a language.



- 3 Press the **POWER/ENTER** button.
[END] appears, and the display returns to the screen in Step 1.

NOTE

- ▶ To cancel the setting, press the DISP button in Step 3.

7-5-5 Displaying version information

Displays the version information for the modules mounted in the product.

The following information can be displayed:

- Main PCB version
- PID version
- Option (Bluetooth function) version
- Sensor PCB version

NOTE

- ▶ The information for [ROM] and [SUM] in [MAIN BOARD VER] is displayed as [----] while they are being calculated.

- 1 Press the ▲/AIR or SHIFT/▼ button in the user mode menu to select [VERSION], then press the POWER/ENTER button.

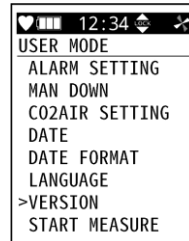

- 2 Press the ▲/AIR or SHIFT/▼ button to select the version information to be displayed.

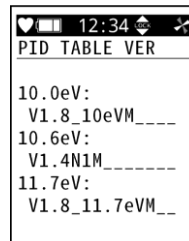
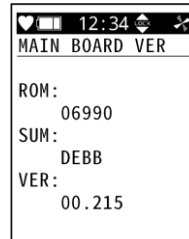

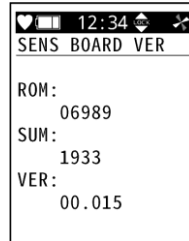
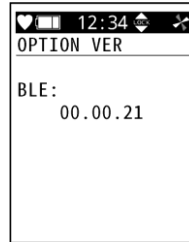

- 3 Press the POWER/ENTER button.**
The display returns to the screen in Step 1.

8

Maintenance

The product is an important safety and disaster-prevention device.

Maintain and inspect the product at regular intervals to ensure performance and to improve disaster prevention and safety reliability.

8-1 Maintenance intervals and items

The following items should be maintained regularly before using the product:

- Daily maintenance: Perform maintenance before work.
- Monthly maintenance: Perform maintenance by testing the alarms once a month.
- Regular maintenance: Perform maintenance at least once a year (ideally, at least once every six months).

Maintenance item	Maintenance details	Daily maintenance	Monthly maintenance	Regular maintenance
Battery level	Check to confirm that battery levels are adequate.	○	○	○
Concentration display	Check to confirm that the concentration reading is 0 (or 20.9 % for oxygen meter) after drawing in fresh air. If the reading is not 0, check to confirm that no miscellaneous gases are present, then perform fresh air adjustment.	○	○	○
Main unit operation	Check the LCD display to confirm the absence of fault indication.	○	○	○
Filter	Check to confirm that the filter is not dirty.	○	○	○
Alarm test	Test the alarms and check to confirm that the alarm LED arrays and buzzer operate correctly.	-	○	○
Span adjustment	Perform span adjustment using a calibration gas.	-	-	○
Gas alarm check	Check the gas alarm with a calibration gas.	-	-	○



WARNING

- If you encounter a product abnormality, contact RIKEN KEIKI immediately.

NOTE

- ▶ Perform span adjustment using calibration gas once every six months.
- ▶ Span adjustment requires dedicated tools and preparation of a calibration gas. Always contact RIKEN KEIKI for span adjustment.
- ▶ The built-in sensors have finite service lives and must be replaced regularly.
- ▶ If the sensors cannot be adjusted using span adjustment, the readings are not restored after fresh air adjustment, or the readings fluctuate, the sensors are at the end of their life. Contact RIKEN KEIKI. For information on sensor warranty periods, see “.

- ▶ The dustproof and waterproof construction IP67 rating does not imply that the product is capable of detecting gas while or after being subjected to such environmental conditions. Be sure to remove any dust or water before use.

<Maintenance service>

RIKEN KEIKI provides services related to regular maintenance, including span adjustment, as well as other adjustments and maintenance.

Preparing calibration gas requires dedicated tools, such as gas cylinders of the specified concentration and gas sampling bags.

Our certified service engineers have expert knowledge of the dedicated tools and products. Please take advantage of the RIKEN KEIKI maintenance service to maintain safe operation of the product.

The major maintenance service items are as follows. Please contact RIKEN KEIKI for more information.

Service	Service details
Battery level check	Checks battery levels.
Concentration display check	Checks to confirm that the concentration reading is zero (20.9 % for oxygen concentration reading and 400 – 500 ppm for carbon dioxide reading) using a zero gas. Fresh air adjustment (zero adjustment) is performed if the reading is not zero.
Filter check	Checks the dust filter for contamination and clogging. The filter is replaced if dirty or clogged.
Alarm test	Alarm tests are performed to confirm that the alarm lamps and buzzer operate correctly.
Span adjustment	Adjusts sensitivity using a calibration gas.
Gas alarm check	Checks the gas alarm using a calibration gas. <ul style="list-style-type: none"> • Alarm check (Confirms alarm activation when alarm setpoint is reached.) • Delay time check (Checks delay time until alarm activation.) • Buzzer, LEDs, and concentration reading check (Checks operation for each alarm.)
Product cleaning and repair (Visual inspection)	Checks the product exterior for dirt and cleaning/repairing of visible areas. Parts are replaced if cracked or damaged.
Product operation check	Operates the buttons to check functions and parameters.
Consumable part replacement	Replaces degraded components such as sensors and filters.

8-2 Performing gas adjustment

Gas adjustment requires dedicated tools and a calibration gas.
Contact RIKEN KEIKI to request gas readjustment.



CAUTION

- Do not use lighter gas to check the sensitivity of the product. Constituents in lighter gas may degrade sensor performance.
- Due to the way the sensor operates, an accurate reading may not be displayed immediately after turning on the power. Allow the product to warm up for at least one minute to allow the reading to stabilize before use. Allow the product to warm up for at least 10 minutes before performing gas adjustment.

8-2-1 Preparation for gas adjustment

<Required equipment/materials>

- Calibration gas (sold separately)
- Gas sampling bag (sold separately) or demand flow valve (sold separately)*

* Used to extract gas from the gas cylinder

<Example gas supply method>

Connect the equipment to the product as shown below to draw in the calibration gas, then adjust once the reading has risen. For information on the calibration gas type and calibration gas introduction time, see '<Recommended calibration gas concentrations and introduction times>'.
'

Using a gas sampling bag

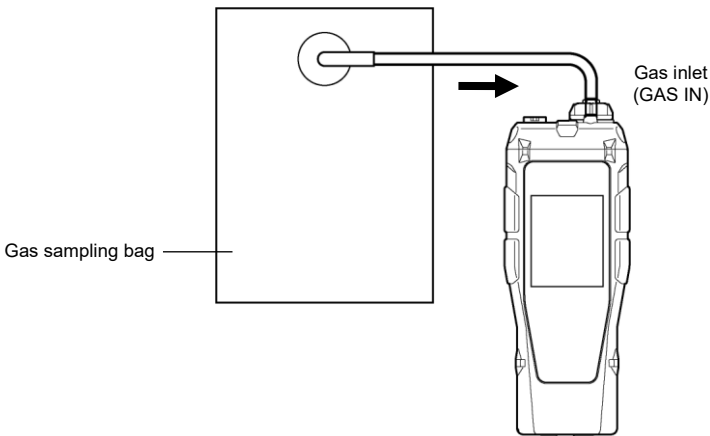

Using a demand flow valve (and gas cylinder)

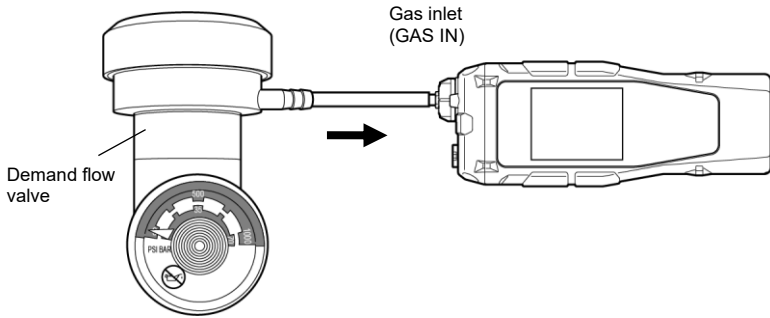

<Recommended calibration gas concentrations and introduction times>

Sensor	Detection target gas	Calibration gas	Calibration gas concentration	Gas introduction time
NCR-6309	Methane (CH ₄) Isobutane (HC (i-C ₄ H ₁₀))	Methane (CH ₄) Isobutane (HC (i-C ₄ H ₁₀))	50 %LEL	60 seconds
ESR-X13P	Oxygen (O ₂)	Oxygen (O ₂)	12.0 %	60 seconds
ESR-A13P/ ESR-A1DP	Hydrogen sulfide (H ₂ S)	Hydrogen sulfide (H ₂ S)	25.0 ppm	60 seconds
ESR-A13P/ ESR-A1DP/ ESR-A1CP	Carbon monoxide (CO)	Carbon monoxide (CO)	50 ppm	60 seconds
ESS-03DH	Sulfur dioxide (SO ₂)	Sulfur dioxide (SO ₂)	10.00 ppm	120 seconds
ESS-03DH	Nitrogen dioxide (NO ₂)	Nitrogen dioxide (NO ₂)	10.00 ppm	120 seconds
ESS-03DH	Hydrogen cyanide (HCN)	Hydrogen cyanide (HCN) or phosphine (PH ₃) (replacement gas)	Depends on calibration gas.	120 seconds
ESS-B332	Ammonia (NH ₃)	Ammonia (NH ₃)	40 ppm	120 seconds
ESS-B335	Chlorine (Cl ₂)	Chlorine (Cl ₂)	0.80 ppm	120 seconds
ESS-03DH	Phosphine (PH ₃)	Phosphine (PH ₃)	0.48 ppm	60 seconds
DES-3311-1	Carbon dioxide (CO ₂ , vol%)	Carbon dioxide (CO ₂)	2.50 vol%	60 seconds
DES-3311-4	Carbon dioxide (CO ₂ , ppm)	Carbon dioxide (CO ₂)	5,000 ppm	60 seconds
DES-3311-2	Isobutane (HC (i-C ₄ H ₁₀))	Isobutane (HC (i-C ₄ H ₁₀))	50 %LEL	60 seconds
DES-3311-3	Methane (CH ₄)	Methane (CH ₄)	50 %LEL	60 seconds
PIS-001A	Volatile organic compounds (VOC, 10.6 eV, ppm)	Isobutylene (C ₄ H ₈)	20,000 ppb	60 seconds
PIS-002A	Volatile organic compounds (VOC, 10.6 eV, ppm)	Isobutylene (C ₄ H ₈)	100.0 ppm	60 seconds
PIS-003	Volatile organic compounds (VOC, 10.0 eV, ppm)	Isobutylene (C ₄ H ₈)	20.0 ppm	60 seconds
SHS-8661	Isobutane (HC (i-C ₄ H ₁₀))	Isobutane (HC (i-C ₄ H ₁₀))	1,800 ppm	60 seconds
SHS-8661	Methane (CH ₄)	Methane (CH ₄)	150 ppm	60 seconds
TE-7561	Methane (CH ₄)	Methane (CH ₄) (N ₂ -based)	50 vol%	60 seconds

**WARNING**

- Do not apply pressure to the gas sampling bag when attaching it. Otherwise this may cause the calibration gas to leak inside, preventing correct adjustment.

About the calibration gas

- Calibration gases include hazardous gases (e.g., combustible gases, toxic gases, oxygen deficiency). Take care when handling the gases and the related equipment.

Gas sampling bag

- Use different gas sampling bags for each gas type and concentration to ensure accurate adjustment.

Gas adjustment location

- Do not perform gas adjustment in a confined space.
- Do not perform gas adjustment in locations where gases such as silicone and spray can gases are used.
- Perform gas adjustment in an environment as close as possible to the gas measurement environment.
- Calibrate indoors at normal temperatures with no significant fluctuations (within ± 5 °C).
- Always perform adjustment in an exhaust booth or recover the calibration gas by attaching an exhaust bag to the gas outlet (GAS OUT).

Gas adjustment using a replacement gas

- To perform gas adjustment using a replacement gas, the replacement gas must be selected in [SPAN GAS SELECT]. (See '<Set the calibration gas for span adjustment>' in '8-2-4 Setting span adjustment'.)
 - Set the gas concentration as indicated in [SETTING CAL-P] for setting the calibration gas concentration to be used. (See '<Set the gas concentration for span adjustment>' in '8-2-4 Setting span adjustment'.)
-
-

**CAUTION**

- Keep in mind that using a gas mixture to perform span adjustment may affect indication accuracy. This is due to interference by gases other than the target gas. See '12-5 List of interference gases for electrochemical type sensors' to avoid combinations of gases that are known to cause interference.
-
-

NOTE

- ▶ The recommended calibration gas concentration and introduction time are the same as above for the bump test also.
 - ▶ The concentrations listed above are the recommended calibration gas concentrations. If the calibration gas concentration used differs, alter the concentration setting and perform gas adjustment.
-
-

<Gas adjustment menu>

Gas adjustment is performed using [GAS CAL] in user mode.

The following menu displayed in [GAS CAL] allows individual items to be run and set.

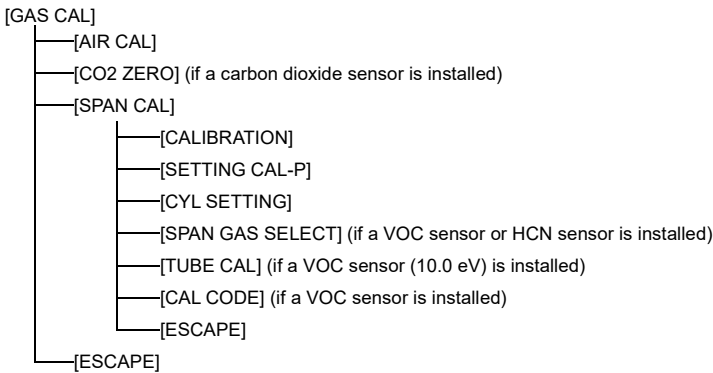

NOTE

- ▶ With the power turned off, press the POWER/ENTER button and ▲/AIR button simultaneously to switch to user mode. (See '7-2 Switching to user mode'.)
- ▶ To return to the previous menu screen, press the DISP button.
- ▶ It is possible to enter measurement mode from [SPAN CAL]. Switch from [SPAN CAL] to [CALIBRATION], press the ▲/AIR or SHIFT/▼ button several times to select [START MEASURE], then press the POWER/ENTER button. User mode ends, and the product operates in the same way as when turning on the power and enters measurement mode.
- ▶ Tube adjustment refers to the function for adjusting using benzene for the benzene select mode. For more information, contact RIKEN KEIKI. (For information on the simplified adjustment method, refer to '<Entering the pre-filter tube calibration code>'.)



WARNING

- Return to measurement mode manually once gas adjustment ends. The product does not return automatically to measurement mode from user mode.

8-2-2 Performing fresh air adjustment

Fresh air adjustment must be performed before measuring gas concentration.

For information on individual sensor adjustment methods and precautions, see '5-6 Performing fresh air adjustment'.

- 1 Press the ▲/AIR or SHIFT/▼ button in the user mode menu to select [GAS CAL], then press the POWER/ENTER button.

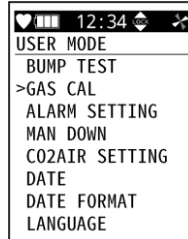

- 2 Press the ▲/AIR or SHIFT/▼ button in the [GAS CAL] menu to select [AIR CAL], then press the POWER/ENTER button.

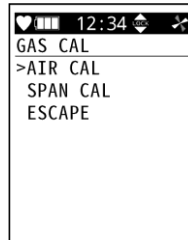

- 3 Hold down the ▲/AIR button.

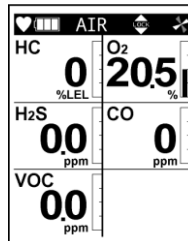

Fresh air adjustment is performed.

Hold down the ▲/AIR button for as long as the screen shown on the right is displayed.

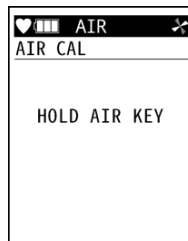

- 4 Release the **▲/AIR** button once **[RELEASE AIR KEY]** appears on the screen.

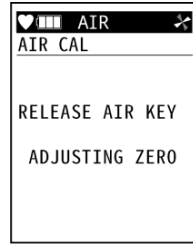

Once fresh air adjustment has been successfully completed, the result is displayed, and the concentration after fresh air adjustment is then displayed.

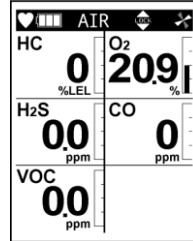
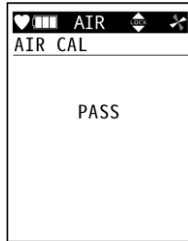

The display returns to the screen in Step 2.

NOTE

- ▶ If fresh air adjustment fails, **[FAIL]** appears in the gas concentration display area for the failed sensor. Press the **RESET** button to reset the fault alarm (adjustment failure). Fresh air adjustment will not be performed on the sensor for which fresh air adjustment failed, and the current gas concentration is displayed.
- ▶ If fresh air adjustment fails, repeat fresh air adjustment in clean air. If fresh air adjustment still fails, the sensor is likely to be faulty. Contact RIKEN KEIKI.

8-2-3 Performing CO₂ zero adjustment

CO₂ zero adjustment must be performed if a carbon dioxide sensor is installed.

CO₂ zero adjustment can be performed by using either nitrogen (N₂) for the calibration gas or the CF-284 CO₂ removal filter.



WARNING

- Air contains carbon dioxide (CO₂) at a concentration of approximately 400 – 500 ppm. Correct gas concentration measurements are not possible if CO₂ zero adjustment is performed in air without the CF-284 CO₂ removal filter.



CAUTION

- Do not draw in carbon dioxide (CO₂) during CO₂ zero adjustment.
- Do not breathe over the gas inlet during CO₂ zero adjustment.

NOTE

- ▶ If no sensors requiring CO₂ zero adjustment are installed, [CO₂ ZERO] will not appear in the user mode [GAS CAL] menu.

<When using nitrogen (N₂) for the calibration gas>

When using nitrogen (N₂) for the calibration gas, introduce via GAS IN for approximately 60 seconds.

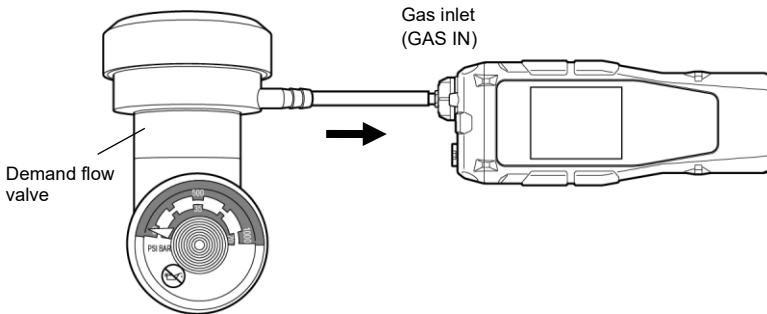

<When using the CF-284 CO₂ removal filter>

If nitrogen (N₂) is not used for the calibration gas, the CF-284 CO₂ removal filter must be used to remove carbon dioxide (CO₂) from the air. Attach the CF-284 CO₂ removal filter with the arrow on the side pointing toward the gas inlet (GAS IN) of the main unit, then draw in air for approximately 60 seconds before starting CO₂ zero adjustment.

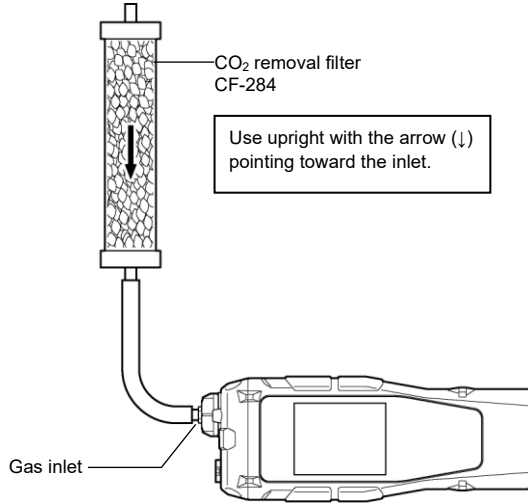

CAUTION

- Use the CO₂ removal filter held upright. Drawing in air with the filter oriented horizontally may prevent removal of carbon dioxide (CO₂) from the air, as the air passes through the upper part inside the CO₂ removal filter tube.
- After using the CO₂ removal filter, block the air flow. The absorbing agent will absorb carbon dioxide (CO₂) from the air if left exposed to air, reducing absorbency.
- Store the CO₂ removal filter in a dry location not exposed to direct sunlight.

NOTE

- ▶ The number of times a CO₂ removal filter can be used depends on the concentration of carbon dioxide in the air. It also depends on the airtightness of the filter and the storage temperature and humidity.
- ▶ The following table gives guideline figures for the number of uses when used to draw in air for one minute at a time. Provide a margin of error in cases in which the environmental concentration of carbon dioxide cannot be determined.

Carbon dioxide concentration in measurement environment	Expected number of uses
500 ppm	Approx. 1,000 times
1,000 ppm	Approx. 500 times
2,000 ppm	Approx. 200 times
4,000 ppm	Approx. 100 times

- 1 Press the ▲/AIR or SHIFT/▼ button in the user mode menu to select [GAS CAL], then press the POWER/ENTER button.

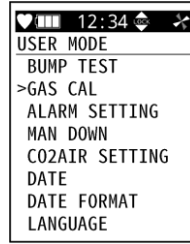

- 2 Press the ▲/AIR or SHIFT/▼ button in the [GAS CAL] menu to select [CO2 ZERO], then press the POWER/ENTER button.

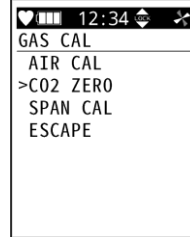

- 3 Introduce nitrogen (N₂) or air, wait 60 seconds, then press the POWER/ENTER button.

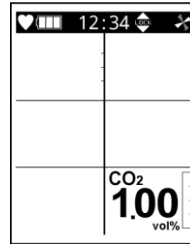

CO₂ zero adjustment is performed.

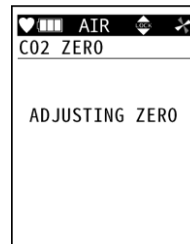

Once CO₂ zero adjustment has been successfully completed, the result is displayed, and the concentration after CO₂ zero adjustment is then displayed.

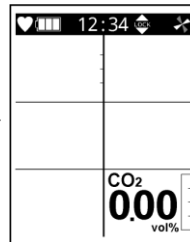
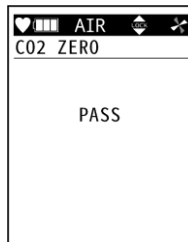

The display returns to the screen in Step 2.

NOTE

- ▶ If CO₂ zero adjustment fails, [FAIL] appears in the carbon dioxide sensor gas concentration display area.
Press the RESET button to reset the fault alarm (adjustment failure). CO₂ zero adjustment will not be performed if CO₂ zero adjustment failed, and the current gas concentration is displayed.
 - ▶ To cancel CO₂ zero adjustment, press the DISP button in Step 3.
 - ▶ When the CO₂ fresh air adjustment setting is enabled and fresh air adjustment is performed, the carbon dioxide sensor will be automatically set to 400 ppm for the air drawn in regardless of the actual carbon dioxide concentration. (See '7-5-1 Enabling/disabling CO₂ fresh air adjustment'.) Caution is required here, as this state no longer satisfies the normal product specifications.
To adjust the carbon dioxide sensor to zero, perform CO₂ zero adjustment.
-

8-2-4 Setting span adjustment

The cylinders, calibration gas concentration, and calibration gas can be set for span adjustment.

<Set the cylinders>

Set the sensor groups (cylinders) for adjustment. When using cylinders with mixtures of multiple gases, gas adjustment can be performed simultaneously for the gases set to the same cylinder. Set based on the cylinders used.

Cylinders A to G can be set.

The default cylinder settings are as follows:

Sensor model	Detection target gas	Default cylinder setting
NCR-6309	Methane (CH ₄ , %LEL) Isobutane (HC (i-C ₄ H ₁₀), %LEL)	A
ESR-X13P	Oxygen (O ₂)	A
ESR-A13i/ ESR-A1DP	Hydrogen sulfide (H ₂ S)	B (Japan Ex model) A (ATEX/IECEX model)
ESR-A13P/ ESR-A1DP/ ESR-A1CP	Carbon monoxide (CO)	A
ESS-03DH	Sulfur dioxide (SO ₂)	Smart sensor 1: E Smart sensor 2: F (For information on which is sensor 1 and which is sensor 2, see '1-3 Checking the detection target gases and product specifications'.)
ESS-03DH	Nitrogen dioxide (NO ₂)	
ESS-03DH	Hydrogen cyanide (HCN)	
ESS-B332	Ammonia (NH ₃)	
ESS-B335	Chlorine (Cl ₂)	
ESS-03DH	Phosphine (PH ₃)	
DES-3311-2	Isobutane (HC (i-C ₄ H ₁₀))	
DES-3311-3	Methane (CH ₄)	
DES-3311-1	Carbon dioxide (CO ₂ , vol%)	
DES-3311-4	Carbon dioxide (CO ₂ , ppm)	
PIS-001A	Volatile organic compounds (VOC, 10.6 eV, ppb)	
PIS-002A	Volatile organic compounds (VOC, 10.6 eV, ppm)	
PIS-003	Volatile organic compounds (VOC, 10.0 eV, ppm)	
SHS-8661	Methane (CH ₄ , ppm) Isobutane (HC (i-C ₄ H ₁₀), ppm)	
TE-7561	Methane (CH ₄ , vol%)	

- 1 Press the ▲/AIR or SHIFT/▼ button in the user mode menu to select [GAS CAL], then press the POWER/ENTER button.

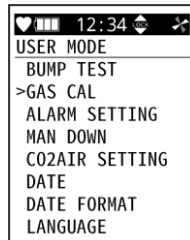

- 2 Press the ▲/AIR or SHIFT/▼ button in the [GAS CAL] menu to select [SPAN CAL], then press the POWER/ENTER button.

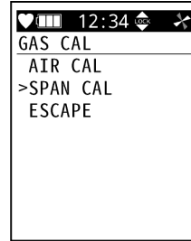

- 3 Press the ▲/AIR or SHIFT/▼ button to select [CYL SETTING], then press the POWER/ENTER button.

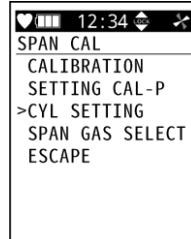

- 4 Press the ▲/AIR or SHIFT/▼ button to select the sensor, then press the POWER/ENTER button.

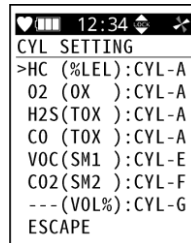

- 5 Press the ▲/AIR or SHIFT/▼ button to set the cylinder, then press the POWER/ENTER button. Pressing the button cycles through the settings in the following sequence: [CYL-A] → [CYL-B] → [CYL-C] ... [CYL-G].

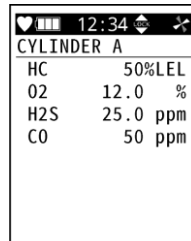

[END] appears, and the display returns to the screen in Step 4.

NOTE

- ▶ To cancel the setting, press the DISP button in Step 5.

<Set the gas concentration for span adjustment>

The calibration gas concentration for span adjustment can be set within the following ranges for each sensor. Gas concentration can be set in increments corresponding to the resolution.



WARNING

Gas adjustment using a replacement gas

To perform gas adjustment using a replacement gas, first set the calibration gas to the replacement gas using the procedure described in '<Set the calibration gas for span adjustment>'. Next, set the concentration of the prepared replacement gas in [SETTING CAL-P] following the procedure below. To perform gas adjustment using a replacement gas, a conversion factor must be applied. Once the calibration gas is set to the replacement gas, the gas concentration for [SETTING CAL-P] and that displayed during span adjustment will be the value reflecting the conversion factor (replacement gas concentration).

Sensor	Detection target gas	Resolution	Setting range lower limit	Setting range upper limit
NCR-6309	Methane (CH ₄) Isobutane (HC (i-C ₄ H ₁₀))	1 %LEL	1 %LEL	60 %LEL
ESR-X13P	Oxygen (O ₂)	0.1 %	0.0 %	25.0 %
ESR-A13i/ ESR-A1DP	Hydrogen sulfide (H ₂ S)	0.1 ppm	0.5 ppm	200.0 ppm
ESR-A13P/ ESR-A1DP/ ESR-A1CP	Carbon monoxide (CO)	1 ppm	12 ppm	2,000 ppm
ESS-03DH	Sulfur dioxide (SO ₂)	0.05 ppm	0.00 ppm	99.90 ppm
ESS-03DH	Nitrogen dioxide (NO ₂)	0.05 ppm	0.00 ppm	20.00 ppm
ESS-03DH	Hydrogen cyanide (HCN)	0.1 ppm	0.0 ppm	15.0 ppm
ESS-B332	Ammonia (NH ₃)	0.5 ppm	0.0 ppm	400.0 ppm
ESS-B335	Chlorine (Cl ₂)	0.05 ppm	0.00 ppm	10.00 ppm
ESS-03DH	Phosphine (PH ₃)	0.01 ppm	0.00 ppm	20.00 ppm
DES-3311-2	Isobutane (HC (i-C ₄ H ₁₀))	1 %LEL/0.5 vol%	0 %LEL	30.0 vol%
DES-3311-3	Methane (CH ₄)	1 %LEL/0.5 vol%	0 %LEL	100.0 vol%
DES-3311-1	Carbon dioxide (CO ₂ , vol%)	0.02 vol%	0.00 vol%	10.00 vol%
DES-3311-4	Carbon dioxide (CO ₂ , ppm)	20 ppm	0 ppm	10,000 ppm
PIS-001A	Volatile organic compounds (VOC, 10.6 eV, ppm)	1 ppb (0 – 4,000 ppb) 10 ppb (4,000 – 40,000 ppb)	0 ppb	40,000 ppb
PIS-002A	Volatile organic compounds (VOC, 10.6 eV, ppm)	0.1 ppm (0 – 400.0 ppm) 1 ppm (400.0 – 4,000 ppm)	0.0 ppm	4,000 ppm

PIS-003	Volatile organic compounds (VOC, 10.0 eV, ppm)	0.01 ppm (0 – 10.00 ppm) 0.1 ppm (10.00 – 100.0 ppm)	0.00 ppm	100.0 ppm
SHS-8661	Isobutane (HC (i-C ₄ H ₁₀))	10 ppm	0 ppm	2,000 ppm
SHS-8661	Methane (CH ₄)	10 ppm	0 ppm	5,000 ppm
TE-7561	Methane (CH ₄)	1 vol%	0 vol%	100 vol%

- 1 Press the ▲/AIR or SHIFT/▼ button in the user mode menu to select [GAS CAL], then press the POWER/ENTER button.

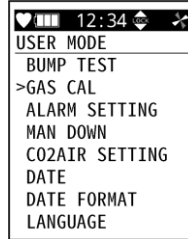

- 2 Press the ▲/AIR or SHIFT/▼ button in the [GAS CAL] menu to select [SPAN CAL], then press the POWER/ENTER button.

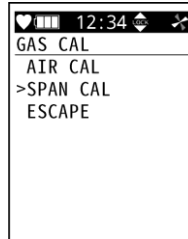

- 3 Press the ▲/AIR or SHIFT/▼ button to select [SETTING CAL-P], then press the POWER/ENTER button.

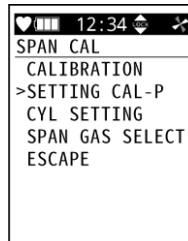

- 4 Press the ▲/AIR or SHIFT/▼ button to select the sensor, then press the POWER/ENTER button.

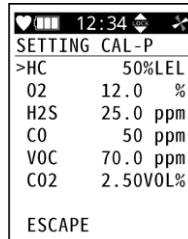

- 5 Press the ▲/AIR or SHIFT/▼ button to set the gas concentration for span adjustment, then press the POWER/ENTER button.

[END] appears, and the display returns to the screen in Step 4.

NOTE

- ▶ Press the ▲/AIR or SHIFT/▼ button when setting the gas concentration for span adjustment to change the value in increments corresponding to the resolution.
- ▶ Hold down the ▲/AIR or SHIFT/▼ button (for less than seven seconds) when setting the gas concentration for span adjustment to change the value in increments corresponding to 10 times the resolution. In addition, hold down the button for seven seconds or more to change the value in increments corresponding to more than 10 times the resolution.
- ▶ To cancel the setting, press the DISP button in Step 5.
- ▶ Span adjustment should be performed using the calibration gas concentration indicated in '8-2-1 Preparation for gas adjustment'.

<Set the calibration gas for span adjustment>

Set the calibration gas used for span adjustment.

The calibration gas can be set if a VOC sensor or HCN sensor is installed.

The gases selectable for a VOC sensor are the gas set in the volatile organic compound (VOC) conversion setting and isobutylene (C₄H₈). The gas selectable for an HCN sensor is phosphine (PH₃).

For information on the volatile organic compound (VOC) conversion setting, see '6-4-4 Volatile organic compound (VOC) conversion gas selection'.

NOTE

- ▶ If no VOC sensor is installed, [SPAN GAS SELECT] will not appear in the user mode [SPAN CAL] menu.

- 1 Press the ▲/AIR or SHIFT/▼ button in the user mode menu to select [GAS CAL], then press the POWER/ENTER button.

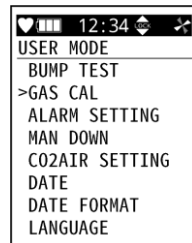

- 2 Press the ▲/AIR or SHIFT/▼ button in the [GAS CAL] menu to select [SPAN CAL], then press the POWER/ENTER button.

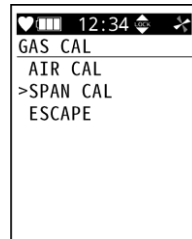

- 3 Press the ▲/AIR or SHIFT/▼ button to select [SPAN GAS SELECT], then press the POWER/ENTER button.

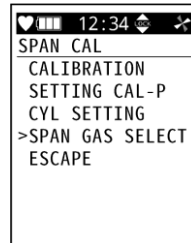

- 4 Press the ▲/AIR or SHIFT/▼ button to select the sensor, then press the POWER/ENTER button.

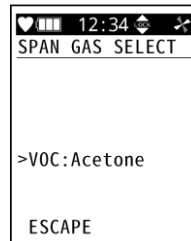

- 5 Press the ▲/AIR or SHIFT/▼ button to select the calibration gas for span adjustment, then press the POWER/ENTER button. [END] appears, and the display returns to the screen in Step 4.

NOTE

- ▶ To cancel the setting, press the DISP button in Step 5.
-

8-2-5 Performing span adjustment

Gas adjustment can be performed for gas types selected from cylinders A to G. Prepare the calibration gas beforehand. (See '8-2-1 Preparation for gas adjustment'.)



CAUTION

- Keep in mind that using a gas mixture to perform span adjustment may affect indication accuracy. This is due to interference by gases other than the target gas. See '12-5 List of interference gases for electrochemical type sensors' to avoid combinations of gases that are known to cause interference.

NOTE

- ▶ Be sure to perform fresh air adjustment before performing span adjustment.
- ▶ If a carbon dioxide sensor is installed, CO₂ zero adjustment (see '8-2-3 Performing CO₂ zero adjustment') or fresh air adjustment (when enabled in '7-5-1 Enabling/disabling CO₂ fresh air adjustment') must always be performed before span adjustment.
- ▶ The calibration gas concentration, cylinders, and calibration gas can be set for span adjustment. (See '8-2-4 Setting span adjustment'.)
- ▶ When the automatic start after successful adjustment function is enabled and the cylinder setting is A only, measurement will start automatically after a successful span adjustment. (The default setting is enabled.)
The automatic start after successful adjustment function can be modified in the configuration program.
- ▶ When a replacement gas is set for the calibration gas, the gas concentration displayed during span adjustment will be the value reflecting the conversion factor (replacement gas concentration). (See '<Set the calibration gas for span adjustment>' in '8-2-4 Setting span adjustment'.)

- 1 Press the ▲/AIR or SHIFT/▼ button in the user mode menu to select [GAS CAL], then press the POWER/ENTER button.

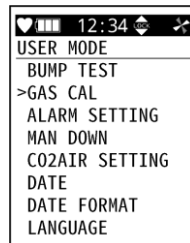

- 2 Press the ▲/AIR or SHIFT/▼ button in the [GAS CAL] menu to select [SPAN CAL], then press the POWER/ENTER button.

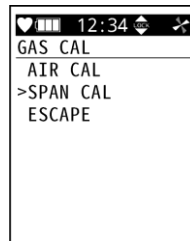

- 3 Press the ▲/AIR or SHIFT/▼ button in the [SPAN CAL] menu to select [CALIBRATION], then press the POWER/ENTER button.

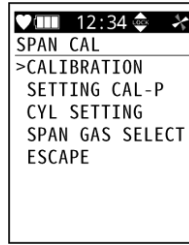

- 4 Press the ▲/AIR or SHIFT/▼ button to select the cylinder to be adjusted, then press the POWER/ENTER button.

Pressing the button cycles through the settings in the following sequence: [CYLINDER A] → [CYLINDER B] →... [CYLINDER G].

Note that cylinders not set will not be displayed.

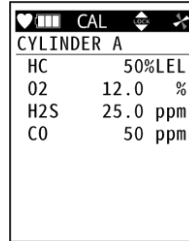

- 5 Introduce the calibration gas for span adjustment, wait 60 or 120 seconds, then press the POWER/ENTER button.

The gas introduction time differs depending on the gas type.

(See '8-2-1 Preparation for gas adjustment'.)

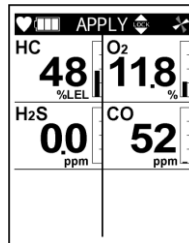

Span adjustment is performed.

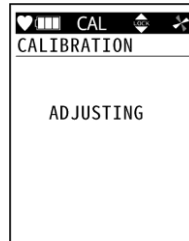

Once span adjustment has been successfully completed, the result is displayed, and the concentration after span adjustment is then displayed.

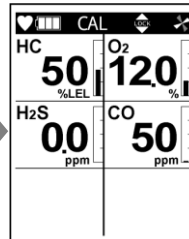
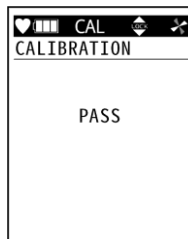

[END] appears, and the display returns to the screen in Step 4.

NOTE

- ▶ If span adjustment fails, [FAIL] appears in the gas concentration display area for the failed sensor. Press the RESET button to reset the fault alarm (adjustment failure). Span adjustment will not be performed on the sensor for which span adjustment failed, and the current gas concentration is displayed.
 - ▶ To cancel span adjustment, press the DISP button in Step 5.
-

8-3 Performing bump tests

The product includes a function for performing bump tests.

Bump tests can be performed for gas types selected from cylinders A to G.

Prepare the bump test gas in the same way as for gas adjustment, and connect it to the main unit. (See '8-2-1 Preparation for gas adjustment'.)

Bump tests are performed using [BUMP TEST] in user mode.

NOTE

- ▶ With the power turned off, press the POWER/ENTER button and ▲/AIR button simultaneously to switch to user mode. (See '7-2 Switching to user mode'.)
- ▶ To exit [BUMP TEST], press the ▲/AIR or SHIFT/▼ button several times to select [ESCAPE], then press the POWER/ENTER button or press the DISP button. The display returns to the user mode menu.
- ▶ It is possible to enter measurement mode from [BUMP TEST]. Press the ▲/AIR or SHIFT/▼ button several times in [BUMP TEST] to select [START MEASURE], then press the POWER/ENTER button. User mode ends, and the product operates in the same way as when turning on the power and enters measurement mode.
- ▶ Use the specified calibration gas for each sensor to perform bump tests.
For VOC sensors, this is isobutylene (C₄H₈), a volatile organic compound (VOC).
- ▶ When the automatic start after successful bump test function is enabled and the cylinder setting is A only, measurement will start automatically after a successful bump test. (The default setting is enabled.)
The automatic start after successful bump test function can be modified in the configuration program.
- ▶ The default settings for bump test execution conditions are as follows:
 - Test time: 30 seconds
 - Tolerance (%): 50 %
 - Adjustment time: 90 seconds
 - Bump adjustment: ON
- ▶ The following criteria for executing a bump test can be modified in the configuration program.
 - Tolerance (%): Threshold for checking the calibration gas
 - Gases other than oxygen (O₂): Adjustment concentration ± (adjustment concentration × tolerance (%))
 - Oxygen (O₂): Adjustment concentration ± (difference between adjustment concentration and 20.9 % × tolerance (%))
 - Adjustment time after test failure: Adjustment time - test time

- 1 Press the ▲/AIR or SHIFT/▼ button in the user mode menu to select [BUMP TEST], then press the POWER/ENTER button.

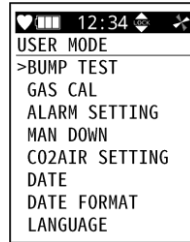

- 2 Press the ▲/AIR or SHIFT/▼ button to select the cylinder to be adjusted, then press the POWER/ENTER button.
 Pressing the button cycles through the settings in the following sequence: [CYLINDER A] → [CYLINDER B] → ... [CYLINDER G].
 Note that cylinders not set will not be displayed.

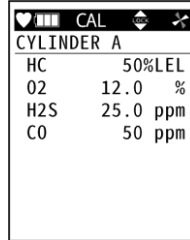

- 3 Introduce the bump test gas, then press the POWER/ENTER button.

The bump test is performed.
 The bump test remaining time is displayed at the top of the screen.

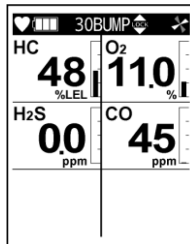

If the bump adjustment function is enabled, the product will automatically perform gas adjustment in the event of a bump test failure.

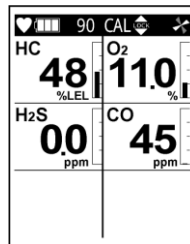

The results are displayed when the bump test and gas adjustment end.

- Bump test and gas adjustment results
- The bump test result is displayed on the left side of the concentration display area, and the gas adjustment result is displayed on the right side.

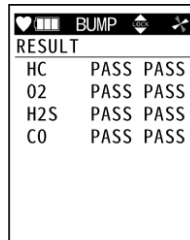

- 4 Press the POWER/ENTER button.
 [END] appears, and the display returns to the screen in Step 2.

NOTE

- ▶ If the setting to perform gas adjustment after a bump test failed is disabled (the default setting is enabled), the bump test result is displayed when the bump test ends. In this case, only the bump test result and bump test gas concentration are displayed.
- ▶ To cancel the bump test, press the DISP button in Step 3.
- ▶ If a bump test fails, perform gas adjustment. If gas adjustment also fails, see '10 Troubleshooting'.

**WARNING**

- Return to measurement mode manually once the bump test is complete. The product does not return automatically to measurement mode from user mode.

8-4 Performing alarm tests

Press the POWER/ENTER button while an alarm setpoint is displayed in the display mode alarm setpoint display to test the corresponding alarm.

- 1 **Press the DISP button several times on the measurement mode screen to display the [ALARM POINTS] screen.**
- 2 **Press the POWER/ENTER button.**

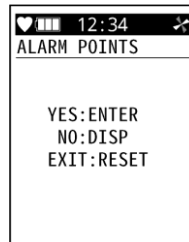

- 3 **Press the ▲/AIR button several times to display the alarm setpoint for the alarm test.**

Pressing the ▲/AIR button cycles through the alarm setpoints in the following sequence:
 [F.S.] (full scale) → [AL1] (first alarm setpoint) → [AL2] (second alarm setpoint) → [AL3] (third alarm setpoint) → [STEL] → [TWA] → [F.S.] (full scale) → ...

- 4 **Press the POWER/ENTER button.**
 This activates the selected alarm setpoint alarm.
 Press the ▲/AIR button, SHIFT/▼ button, or RESET button to stop the alarm test.

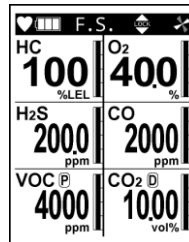
**NOTE**

- ▶ Perform alarm tests periodically.

8-5 Cleaning procedure

Clean the product if it becomes excessively dirty. Be sure to turn off the power before cleaning, and wipe clean using a rag or cloth soaked in water and firmly wrung out.

Do not clean using water, organic solvents or commercially available cleaners for cleaning, as these may cause the product to malfunction.



CAUTION

- When wiping the product clean, do not splash water on it or use organic solvents like alcohol and benzene or commercially available cleaners. These may discolor or damage the surface of the product, or cause the sensor to malfunction.

NOTE

- ▶ Water may remain in the buzzer sound opening or grooves after the product has got wet.

Remove any moisture as follows:

- ① Wipe off any moisture on the product using a dry towel or cloth.
- ② Hold the product firmly and shake about 10 times with the buzzer sound opening facing downward.
- ③ Use a towel or cloth to wipe up all moisture drained from the interior.
- ④ Place the product on a dry towel or cloth and allow to stand at room temperature.

8-6 Parts replacement

8-6-1 Periodic replacement parts

The consumable parts of the product are listed below. Consumable parts should be replaced using the recommended replacement intervals as a guide.

NOTE

- ▶ The recommended replacement intervals are guidelines only. Replacement intervals may vary depending on actual operating conditions. These intervals do not constitute warranty periods. Replacement intervals may vary depending on the results of regular maintenance.

<Recommended replacement parts list>

Name	Recommended maintenance interval	Recommended replacement interval	Quantity (per unit)	Remarks
Interference gas removal filter (CF-6309)*	3 months	6 months	×1	Used when a combustible gas sensor (NCR-6309) is installed. Internal filter Part No. (set of 5): 4777 9315 90
Interference gas removal filter (CF-A13i)*	3 months	6 months	×1	Used when a hydrogen sulfide sensor (ESR-A13i) is installed. Internal filter Part No. (set of 5): 4777 9317 30
Interference gas filter (CF-A1CP)*	3 months	6 months	×1	Used when a carbon monoxide sensor (ESR-A13P/ESR-A1CP) is installed. Internal filter Part No. (set of 5): 4777 9316 60
Interference gas filter (CF-A1DP)*	3 months	6 months	×1	Used when a hydrogen sulfide/carbon monoxide sensor (ESR-A1DP) is installed. Internal filter Part No. (set of 5): 4777 9314 10
Dust filter (internal filter)*	6 months	6 months to 1 year	×1	Internal filter Part No. (set of 10): 4181 9573 10
Activated carbon filter (CF-8350)	6 months	1 year	×1	Used when a VOC sensor is installed. External filter Part No.: 4383 9299 50
CO ₂ removal filter (CF-284)	6 months	1 year	×1	Used when a carbon dioxide sensor is installed. External filter Part No.: 4383 0390 80
Pump unit (RP-12)*	6 months	1 to 2 years	×1	Part No.: 4181 61
Tubes (internal piping)*	-	3 to 8 years	1 set	
Rubber seals*	-	3 to 6 years	1 set	
Lithium ion battery unit (BUL-6100)	-	500 charge/discharge cycles	×1	Only when using the lithium ion battery unit (BUL-6100) Part No.: 4777 0380 10
AA alkaline battery	-	-	×3	Only when using the alkaline dry battery unit (BUD-6100) Part No.: 2753 3007 80
Protective film	-	-	×1	Protects the LCD. Part No. (set of 5): 4777 9064 60

* A function check by a qualified service engineer is required after parts replacement. To ensure safety and the stable operation of the product, request checking by a qualified service engineer. Contact RIKEN KEIKI.

<Recommended replacement parts list (Sensors)>

Sensor model	Detection target gas	Recommended maintenance interval	Recommended replacement interval	Part No.
NCR-6309	Methane (CH ₄) or isobutane (HC (i-C ₄ H ₁₀))	6 months	3 years	4463 10
ESR-X13P	Oxygen (O ₂)	6 months	3 years	4482 02
ESR-A13i	Hydrogen sulfide (H ₂ S)	6 months	3 years	4488 21
ESR-A13P	Carbon monoxide (CO)	6 months	3 years	4488 23
ESR-A1CP	Carbon monoxide (CO)	6 months	3 years	4488 20
ESR-A1DP	Hydrogen sulfide (H ₂ S)/Carbon monoxide (CO)	6 months	3 years	4488 19
DES-3311-1	Carbon dioxide (CO ₂) [vol%]	6 months	5 years	4630 20
DES-3311-2	Isobutane (HC (i-C ₄ H ₁₀))	6 months	5 years	4630 21
DES-3311-3	Methane (CH ₄)	6 months	5 years	4630 22
DES-3311-4	Carbon dioxide (CO ₂) [ppm]	6 months	5 years	4630 23
ESS-03DH	Sulfur dioxide (SO ₂)	6 months	1 year	4486 02
ESS-03DH	Nitrogen dioxide (NO ₂)	6 months	1 year	4486 03
ESS-03DH	Hydrogen cyanide (HCN)	6 months	1 year	4486 04
ESS-B332	Ammonia (NH ₃)	6 months	1 year	4486 06
ESS-B335	Chlorine (Cl ₂)	6 months	1 year	4486 07
ESS-03DH	Phosphine (PH ₃)	6 months	1 year	4486 08
SHS-8661*	Methane (CH ₄) or isobutane (HC (i-C ₄ H ₁₀))	6 months	1 year	4086 61
TE-7561	Methane (CH ₄)	6 months	1 year	4075 61

* Periodic replacement part for hot-wire semiconductor type sensor (SHS-8661)

Sensor model	Description	Detection target gas	Recommended maintenance interval	Recommended replacement interval	Part No.
PIS-001A	Lamp	Volatile organic compounds (VOC, 10.6 eV) [ppb]	6 months	1 year	2594 0870 70
	Pellet		6 months	1 year	2594 0745 20
	Sensor main unit*		6 months	4 years	-
PIS-002A	Lamp	Volatile organic compounds (VOC, 10.6 eV) [ppm]	6 months	1 year	2594 0870 70
	Pellet		6 months	1 year	2594 0746 00
	Sensor main unit*		6 months	4 years	-
PIS-003	Lamp	Volatile organic compounds (VOC, 10.0 eV)	6 months	1 year	2594 0870 70
	Pellet		6 months	1 year	2594 0885 20
	Sensor main unit*		6 months	4 years	-

* Part excluding the lamp and pellet. Note that if you order PIS-001A (part no. 4830 05), PIS-002A (part no. 4830 06), or PIS-003 (part no. 4830 03), the main unit will include a lamp and pellet.

NOTE

- ▶ A function check by a qualified service engineer is required after sensor replacement. To ensure safety and the stable operation of the product, request checking by a qualified service engineer. Contact RIKEN KEIKI.
- ▶ The gas sensitivity of VOC sensors may deteriorate if the sensor interior is contaminated by the gas being measured. If this occurs, the pellet must be replaced and the lamp must be cleaned. (See '8-6-4 VOC sensor maintenance'.) If gas sensitivity does not improve even after cleaning, replace both the lamp and pellet.
- ▶ Depending on the usage frequency and conditions, replacement of the VOC sensor lamp and pellet may become necessary after several months.

8-6-2 Dust filter replacement

The gas inlet part contains a dust filter and metal mesh filter. The dust filter may become dirty and clogged with use, and will need to be replaced depending on the usage conditions. Be sure to replace the dust filter, particularly if water is aspirated, the flow rate drops, or the filter appears especially dirty.

- 1 Rotate the product filter case counterclockwise and remove.

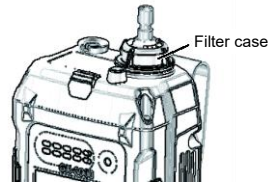

- 2 Remove the dust filter, and replace with a new one.

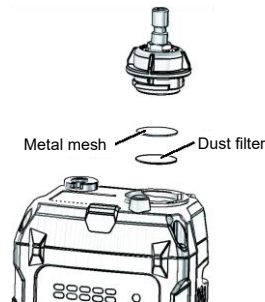

- 3 Rotate the previously removed filter case clockwise to reattach it.

NOTE

- ▶ The dust filter and metal mesh filter are contained inside the main unit.
- ▶ Do not use filters other than those specified by RIKEN KEIKI. Use of non-approved parts may adversely affect gas detection performance and allow water to get inside the product.
- ▶ Install the dust filter correctly. Product performance cannot be guaranteed if it is misaligned.
- ▶ Replace the dust filter every six months. Replace the filter whenever it becomes contaminated even if it is less than six months.
- ▶ When replacing the dust filter, follow the procedure described above, tighten the filter case securely, and make sure that it is securely attached. If the filter case is not securely attached, foreign matter may get inside the product. Foreign matter may also get in if even minute particles are caught between the contact surfaces.
- ▶ Take care not to damage the rubber seals.
- ▶ To maintain performance, we recommend replacing all rubber seals every three to six years, regardless of condition.
- ▶ For information on the replacement filters and rubber seals, see '8-6-1 Periodic replacement parts'.

8-6-3 Interference gas removal filter replacement

Some sensors contain an interference gas removal filter to remove interference gas. The filter may become dirty and clogged with use, and will need to be replaced depending on the usage conditions.

- 1 **Unscrew the four screws securing the sensor cover, then remove the sensor cover.**

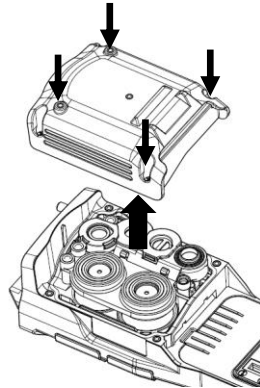

Interference gas removal filter (CF-6309) for combustible gas sensor (NCR-6309)

- 2 **Replace the interference gas removal filter with a new one.**

The hydrogen sulfide/carbon monoxide sensor and filter combinations are as follows:

Detection target gas	Sensor model	Interference gas removal filter model
Hydrogen sulfide (H ₂ S)/carbon monoxide (CO)	ESR-A1DP	CF-A1DP
Hydrogen sulfide (H ₂ S)	ESR-A13i	CF-A13i
Carbon monoxide (CO)	ESR-A1CP	CF-A1CP
	ESR-A13P	

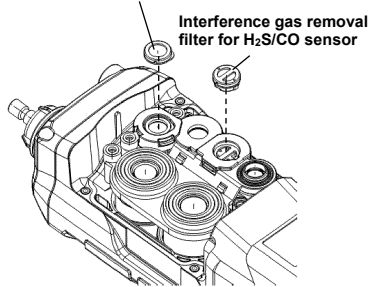

- 3 **Secure the sensor cover in place using the four screws.**

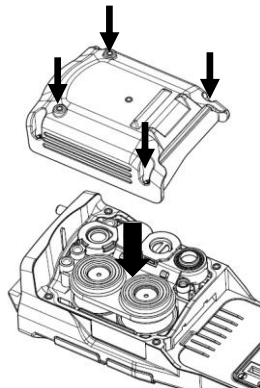

8-6-4 VOC sensor maintenance

The gas sensitivity of VOC sensors may deteriorate if the sensor interior is contaminated by the gas being measured. If this occurs, the pellet must be replaced and the lamp must be cleaned.

NOTE

- ▶ If the gas sensitivity does not improve even after cleaning, replace both the lamp and pellet.
- ▶ Be sure to perform span adjustment after cleaning. (See '8-2-5 Performing span adjustment'.)

<Removing the VOC sensor>

- 1 **Unscrew the four screws securing the sensor cover, then remove the sensor cover.**

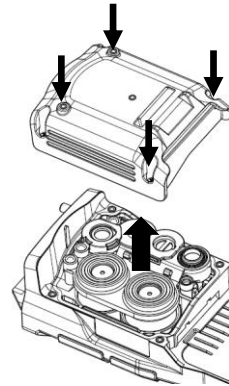

- 2 **Remove the rubber seal.**
Remove the rubber seal without removing the sensor.

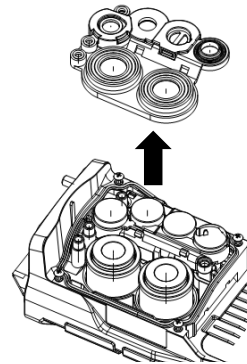

- 3 **Pull out the VOC sensor.**
Grasp the cylindrical part of the sensor and gently pull out.

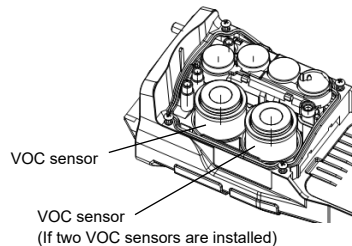

<Removing the pellet and lamp>

Use the pellet removal tool to remove the pellet and lamp from the VOC sensor main unit.

- 1 Place the VOC sensor main unit on a clean surface, with the bottom facing down.
- 2 Fit the pellet removal tool in the side slots of the VOC sensor.

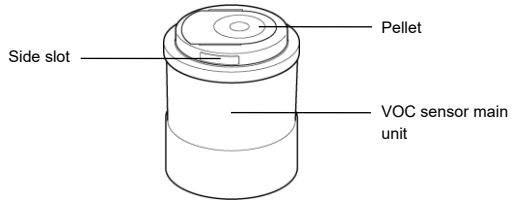
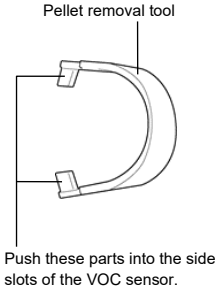

- 3 Press the pellet removal tool on both sides to lift the pellet and lamp from the VOC sensor main unit.

Pushing the pellet removal tool into the side slots on the VOC sensor main unit will lift the pellet to allow removal. Place your hand lightly over the pellet to keep it from flying out on removal.

If the lamp remains inside the VOC sensor main unit, use tweezers or other instrument to remove it.

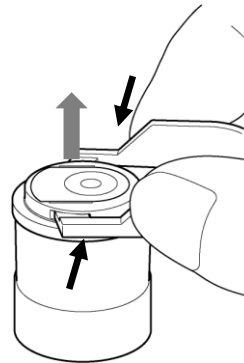

- 4 Place the pellet and lamp on a clean surface. Separate the pellet removal tool from the VOC sensor.

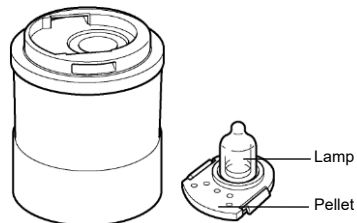

NOTE

- ▶ The small spring at the base of the lamp may come off as the pellet and lamp are removed from the VOC sensor main unit. If this occurs, return the lamp to the VOC sensor main unit, then use tweezers or other instrument to remove the lamp once again.

<Cleaning the lamp>



CAUTION

- Use clean cotton swabs to clean the lamp. Avoid touching the tip of the cotton swab used to clean the lamp with your fingers. Oil from your fingers may soil the lamp if you touch the tip of the cotton swab.
-

1 Place a small amount of alumina polishing powder on a clean cotton swab.

2 Clean the lamp window with the cotton swab until you hear a squeaking sound (within about 15 seconds).

Clean the lamp window in a circular motion, applying gentle pressure.

Avoid touching the lamp window with your fingers while doing this.

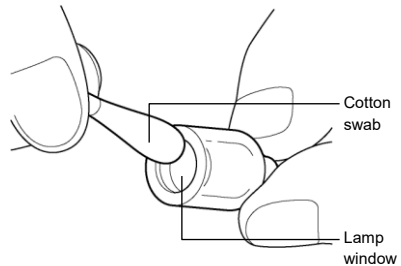

3 Use a clean cotton swab to remove any remaining alumina polishing powder from the lamp window.

4 Confirm that the lamp is completely dry and that no visible soiling remains.

<Mounting the pellet and lamp>

Attach the lamp to a new pellet and insert into the VOC sensor main unit.



CAUTION

- Never reattach a damaged lamp to the pellet.

1 Place a new pellet on a clean, flat surface.

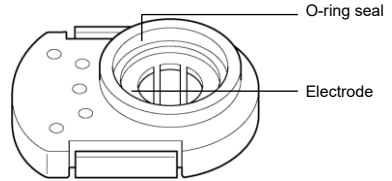

2 Insert the lamp into the O-ring seal of the new pellet.

When inserting the lamp into the pellet, twist slightly. The lamp window will fit into the electrode on the pellet.

3 Twist the lamp into the O-ring seal so that it is closely attached to the electrode plane of the pellet.

Check to confirm that the lamp window is closely attached to the electrode plane of the pellet.

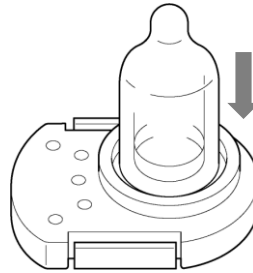

4 Place the pellet into which the lamp has been fitted on a flat surface. Place the VOC sensor main unit over it and press so that the pellet fits into the VOC sensor main unit.

Press in firmly until you hear a click.

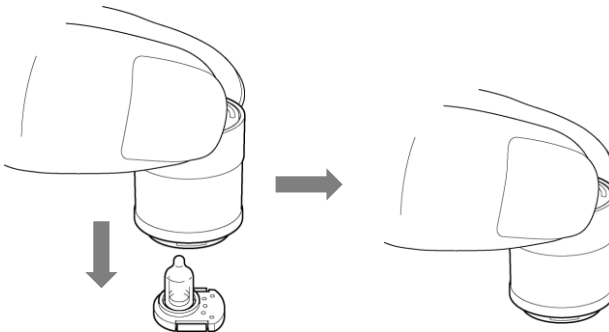

<Installing the VOC sensor>

Install the VOC sensor in the main unit and perform gas adjustment.

1 Attach the VOC sensor.

Grasp the cylindrical part of the sensor to fit to the main unit.

2 Attach the rubber seal to the sensor.

Check to confirm that the filter holders are correctly seated in the rubber seal here. (Six locations circled in figure below)

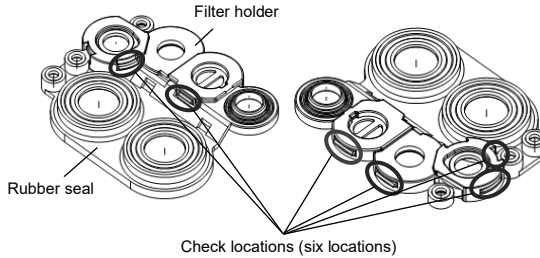

Also check to confirm that the rubber seal is engaged on the two clips on the main unit, and that it is not lifting up.

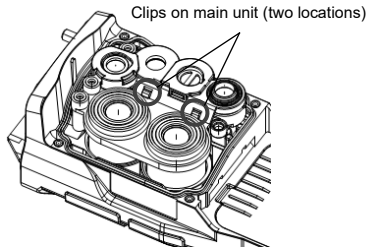

3 Secure the sensor cover in place using the four screws.

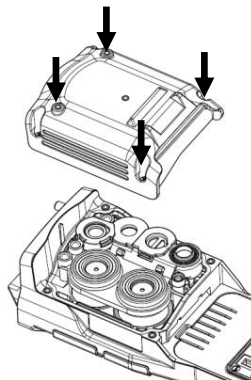

4 Perform gas adjustment.

9

Storage and Disposal

9-1 Procedures for storage or when not in use for extended periods

The product must be stored in the following environment:

- In a dark place at normal temperatures and humidity and away from direct sunlight
- In a location free of gases, solvents, and vapor

Store the product in its shipping carton if this has been retained.

If the shipping carton is not available, store away from dust and dirt.



CAUTION

- Store the product with the lithium ion battery unit or dry battery unit attached. The product constantly draws power for the sensors and clock even when the power is turned off. The sensors may be damaged or the clock display may become offset if there is no power supply.
 - When using the dry battery unit, store the product with the dry batteries left inside. The product constantly requires power for the sensors even when the power is turned off.
 - Even if you do not intend to use the product for extended periods, turn the power on at least once every six months to check pump suction for approximately three minutes. Grease inside the pump motor may solidify and prevent operation unless the product is operated.
-

NOTE

- ▶ If the lithium ion battery unit is stored on its own, we recommend storing after it has been discharged until the battery level icon shows one bar. Storing while fully charged may reduce battery life and accelerate battery deterioration.
 - ▶ If the dry battery unit is stored on its own, remove the batteries before storing.
-

9-2 Procedures for use after storage

Perform gas adjustment if the product is used again after an extended period of storage.



CAUTION

- After storage without use, be sure to perform gas adjustment before resuming use. Contact RIKEN KEIKI to request readjustment of the product, including gas adjustment.
- If there is a temperature difference of 15 °C or more between the storage and usage locations, turn on the power and allow the product to stand for about 10 minutes in a similar environment to the usage location to acclimatize before performing fresh air adjustment in clean air.

9-3 Product disposal

Dispose of the product as industrial waste (incombustible) in accordance with local regulations.



WARNING

- Never disassemble the sensor. Electrochemical type sensors in particular contain hazardous electrolyte. Contact with electrolyte may result in skin inflammation. Contact with eyes may result in blindness. Contact with clothing may result in discoloration or damage to the fabric. If contact occurs, rinse the area immediately with plenty of water.
- Dispose of batteries in accordance with the procedures specified by the local authority.

<Disposal in EU member states>

- Waste Electrical and Electronic Equipment (WEEE) directive



The symbol on the product shown on the left indicates that the product and its individual parts must not be disposed of with general or household waste, and must be sorted and disposed of appropriately.

Proper disposal will help prevent potential negative effects on human health and the environment.

To ensure proper treatment, collection, and recycling of the product at the time of its disposal, please use the return and collection system available in your country. For more information on collecting and recycling used products, please contact the dealer or supplier from whom you purchased the product.

- Battery regulations



The symbol on the product or battery shown on the left indicates that batteries must be disposed of separately from general or household waste.

To ensure proper treatment, collection, and recycling of batteries at the time of their disposal, please dispose of them properly using the collection system available in your country.

10

Troubleshooting

This troubleshooting section does not address causes of all problems that may occur with the product. It provides brief explanations to assist in determining the causes of common problems.

If you encounter symptoms not addressed here or if problems persist even after taking corrective action, contact RIKEN KEIKI.

10-1 Product abnormalities

<Power source related abnormalities>

Symptom/display	Cause	Action
The power cannot be turned on.	<ul style="list-style-type: none"> The battery is depleted. 	Lithium ion battery unit: Charge in a safe place. Dry battery unit: Replace with new dry batteries (all three) in a safe place.
	<ul style="list-style-type: none"> The POWER/ENTER button was pressed for too short or too long a time. 	To turn on the power, hold down the POWER/ENTER button until the buzzer blips, then release the button.
	<ul style="list-style-type: none"> The battery unit is incorrectly attached. 	Check to confirm that the battery unit is correctly attached to the main unit.
Abnormal operation	<ul style="list-style-type: none"> Effects of sudden static electricity noise, etc. 	Turn off the power, then turn it back on again to restart.
The product does not operate.	<ul style="list-style-type: none"> Effects of sudden static electricity noise, etc. 	Remove the battery unit in a safe place, reattach the battery unit, then turn on the power again.
Charging is impossible. (When using lithium ion battery unit)	<ul style="list-style-type: none"> The adapter is not correctly connected. 	Insert the AC plug and DC plug of the AC adapter correctly.
	<ul style="list-style-type: none"> There is a fault in the charging circuit. 	Contact RIKEN KEIKI.
	<ul style="list-style-type: none"> The battery unit is fully charged. 	The charging indicator LED will not light up if you attempt to charge the battery unit when fully charged.

<Low flow rate [FAIL LOW FLOW]>

Cause	Action
<ul style="list-style-type: none"> The flow passage is blocked. 	Fix the problem (e.g., broken pipe, water aspiration). If the problem is not resolved, contact RIKEN KEIKI.
<ul style="list-style-type: none"> The dust filter is clogged. 	Check the dust filter mounting condition and whether it is clogged or twisted. Replace the dust filter if dirty.
<ul style="list-style-type: none"> The pump is deteriorated. 	The pump must be replaced. Contact RIKEN KEIKI.
<ul style="list-style-type: none"> The power was turned on in cold temperatures or after extended periods without use 	Turn the power off and on several times. The pump may start working. If the problem is not resolved even after restarting several times, contact RIKEN KEIKI.
<ul style="list-style-type: none"> Left for extended periods under cold conditions 	The pump valve has frozen, reducing the suction flow rate. Turn the power off and on several times. The product may need to be restarted several times to restore functionality.

<System abnormality [FAIL SYSTEM]>

Fault No.	Cause	Action
000	<ul style="list-style-type: none"> Internal ROM abnormality Effects of abnormal noise 	Contact RIKEN KEIKI.
010	<ul style="list-style-type: none"> Internal RAM abnormality Effects of abnormal noise 	Contact RIKEN KEIKI.
021	<ul style="list-style-type: none"> Internal FRAM abnormality Effects of abnormal noise 	Contact RIKEN KEIKI.
022	<ul style="list-style-type: none"> Abnormal parameters such as alarm setpoints and span adjustment values 	Contact RIKEN KEIKI.
031	<ul style="list-style-type: none"> Internal flash abnormality Data logger writing failed Effects of abnormal noise 	Gas concentration measurement is possible in this state, but the data logger function cannot be used. If this symptom occurs frequently, the flash memory must be replaced. Contact RIKEN KEIKI.
080	<ul style="list-style-type: none"> Main PCB reference voltage abnormality or pressure sensor power supply voltage abnormality Effects of abnormal noise 	Turn off the power, then turn it back on again to restart. If the problem persists, contact RIKEN KEIKI.
081	<ul style="list-style-type: none"> Sensor PCB communication abnormality, status abnormality, or reference voltage abnormality Effects of abnormal noise 	Turn off the power, then turn it back on again to restart. If the problem persists, contact RIKEN KEIKI.
082	<ul style="list-style-type: none"> Internal thermistor abnormality Ambient conditions significantly outside the operating temperature range 	Contact RIKEN KEIKI.
083	<ul style="list-style-type: none"> Bluetooth fault Effects of abnormal noise 	Gas measurement is possible in this state, but the Bluetooth function cannot be used. Repair is required to use the Bluetooth function. Contact RIKEN KEIKI.
084	<ul style="list-style-type: none"> Acceleration sensor fault Effects of abnormal noise 	Turn off the power, then turn it back on again to restart. If the problem persists, contact RIKEN KEIKI.

<Sensor abnormality [FAIL]>

Symptom	Cause	Action
Span adjustment is not possible.	<ul style="list-style-type: none"> The sensor is not correctly installed. The sensor is faulty. 	Check to confirm that the sensor is correctly installed. If the sensor is faulty, it must be replaced. Contact RIKEN KEIKI.
	<ul style="list-style-type: none"> The calibration gas concentration setting differs from the concentration of the calibration gas supplied. 	Check to confirm that the calibration gas concentration setting is the same as the concentration of the calibration gas supplied.
Fresh air adjustment is not possible.	<ul style="list-style-type: none"> The sensor is not correctly installed. The sensor is faulty. 	Check to confirm that the sensor is correctly installed. If the sensor is faulty, it must be replaced. Contact RIKEN KEIKI.
	<ul style="list-style-type: none"> Clean air is not being supplied around the product. 	Supply clean air.
Performing a bump test is not possible.	<ul style="list-style-type: none"> Calibration gas is not being supplied during a bump test. 	Supply the correct calibration gas for the bump test.
	<ul style="list-style-type: none"> The calibration gas concentration setting differs from the concentration of the calibration gas supplied. 	Check to confirm that the calibration gas concentration setting is the same as the concentration of the calibration gas supplied.
	<ul style="list-style-type: none"> Gas adjustment has not been performed. 	Perform fresh air adjustment and span adjustment.
CO ₂ zero adjustment is not possible.	<ul style="list-style-type: none"> The sensor is not correctly installed. The sensor is faulty. 	Check to confirm that the sensor is correctly installed. If the sensor is faulty, it must be replaced. Contact RIKEN KEIKI.
	(When using nitrogen (N ₂) for the calibration gas) <ul style="list-style-type: none"> Calibration gas (nitrogen (N₂)) is not being supplied. 	Supply the calibration gas (nitrogen (N ₂)).
A sensor abnormality is indicated.	<ul style="list-style-type: none"> The sensor is not correctly installed. 	Check to confirm that the sensor is correctly installed.
	<ul style="list-style-type: none"> The sensor is faulty. 	If the sensor is faulty, it must be replaced. Contact RIKEN KEIKI.
	<ul style="list-style-type: none"> There are problems with communicating with the sensor. 	Replace with a new sensor.
	(VOC sensors) <ul style="list-style-type: none"> The PID lamp is dirty. 	Clean the PID lamp. Either clean the lamp or contact RIKEN KEIKI to request maintenance. For information on the cleaning procedure, see '8-6-4 VOC sensor maintenance'.
	(VOC sensors) <ul style="list-style-type: none"> The PID lamp is deteriorated. 	If the PID lamp is deteriorated, it must be replaced. Contact RIKEN KEIKI.
	(VOC sensors) <ul style="list-style-type: none"> The electrode pellet is deteriorated. 	If the electrode pellet is deteriorated, it must be replaced. Contact RIKEN KEIKI.

<Low battery voltage abnormality [FAIL BATTERY]>

Cause	Action
<ul style="list-style-type: none"> Battery exhaustion 	Lithium ion battery unit: Charge in a safe place.
	Dry battery unit: Replace with new dry batteries (all three) in a safe place.

<Clock abnormality [FAIL CLOCK]>

Fault No.	Cause	Action
050	<ul style="list-style-type: none"> Internal clock abnormality Effects of abnormal noise 	Set the date and time. If this symptom occurs frequently, the internal clock must be replaced. Contact RIKEN KEIKI.
051	<ul style="list-style-type: none"> Low backup battery voltage 	Set the date and time. If the problem persists, the backup battery must be replaced. Contact RIKEN KEIKI.

<Other>

Symptom	Cause	Action
[MAINT. DATE PAST] is displayed.	Indicates that more than one year has elapsed since the last adjustment date. (Japan Ex model only)	Contact RIKEN KEIKI to request maintenance.
[CAL DATE PAST] is displayed.	Indicates that the set gas adjustment expiration date has passed. (ATEX/IECEx model only)	Either perform gas adjustment yourself or contact RIKEN KEIKI to request maintenance.
[BUMP DATE PAST] is displayed.	Indicates that the set bump expiration date has passed.	Perform a bump test.
The alarm lamps flash red periodically.	This is normal and indicates that the confirmation beep function is operating. For information on the confirmation beep function, see '5-7-3 Confirmation beep operation'.	-

10-2 Reading abnormalities

Symptom	Cause	Action
The reading rises (or drops) and remains unchanged.	Sensor drift	Perform fresh air adjustment.
	Presence of interference gases	It is difficult to completely eliminate the effects of interference gases such as solvents. Contact RIKEN KEIKI for information on countermeasures, such as removal filters.
	Slow leakage	They may be a very small leakage (slow leakage) of the detection target gas. Leaving this unresolved may lead to hazardous conditions. Take the same action as for gas alarms.
	Ambient condition fluctuations such as temperature and humidity	Perform fresh air adjustment.
	Sensor condensation	Perform fresh air adjustment. Particularly in the case of the oxygen sensor, fresh air adjustment is required as the reading may decrease due to condensation.
Slow response	Dust filter clogging	Replace the dust filter.
	The tapered nozzle is bent or blocked.	Fix the problem.
	There is condensation inside the product.	Fix the problem.
	The sensor sensitivity has degraded.	Replace with a new sensor. Contact RIKEN KEIKI.
The VOC concentration reading rises after zero adjustment, even though the detection target gas is not present.	The electrode pellet is deteriorated.	Replace with a new electrode pellet. Contact RIKEN KEIKI.
The VOC sensor sensitivity is significantly reduced.	The PID lamp is dirty.	Clean the PID lamp. Either clean the lamp or contact RIKEN KEIKI to request maintenance. For information on the cleaning procedure, see '8-6-4 VOC sensor maintenance'.
	The PID lamp is deteriorated.	Replace with a new PID lamp. Contact RIKEN KEIKI.
[----] is displayed on the VOC sensor concentration display, the LEDs flash, and the buzzer sounds.	High concentrations of negative interference gas (such as CH ₄) are present.	Draw in fresh air. Once the effects of the gas have disappeared, measurement will resume automatically after approximately 10 seconds.
	The PID lamp is deteriorated.	Draw in fresh air. If normal operation is not restored even after drawing in fresh air, restart the product. If [FAIL] appears in the gas concentration display area after restarting the product, the sensor is likely to be deteriorated. Replace with a new PID lamp and electrode pellet.
	The electrode pellet is deteriorated.	Contact RIKEN KEIKI.

11

Product Specifications

11-1 Main unit specifications

Item	Specifications
Model	GX-6100
Concentration display	LCD digital (full-dot display)
Detection method	Pump suction type
Suction flow rate	Minimum 0.45 L/min (open flow rate)
Display items	Clock, battery level, operation status
Display languages	Japanese, English, Korean, Chinese (simplified), Chinese (traditional), Vietnamese, Italian, Spanish, Slovak, Czech, German, Turkish, French, Portuguese, Polish, Russian
Volume	Approx. 95 dB (mean value at 30 cm from source, with protective cover fitted)
Gas alarm indication	Lamp flashing, continuous modulating buzzer sounding, gas concentration display blinking, vibration
Gas alarm reset operation	Self-latching, auto-reset (Default setting: Self-latching)
Fault alarm/ self-diagnosis	Flow rate abnormality, system abnormality, sensor abnormality, low battery voltage, adjustment failure, clock abnormality
Fault alarm indication	Lamp flashing, intermittent buzzer sounding, detail display
Fault alarm reset operation	Self-latching
Panic alarm indication ^{*1}	Prealarm: Lamp flashing, intermittent buzzer sounding (prealarm) Main alarm: Lamp flashing, continuous modulating buzzer sounding
Panic alarm reset operation ^{*1}	Self-latching
Man down alarm indication ^{*1}	Prealarm: Lamp flashing, intermittent buzzer sounding (prealarm) Main alarm: Lamp flashing, continuous modulating buzzer sounding
Man down alarm reset operation ^{*1}	Auto-reset
Communication specifications	Bluetooth (Bluetooth Low Energy)
Power source	Dedicated lithium ion battery unit (BUL-6100) or dedicated dry battery unit (AA alkaline batteries × 3) (BUD-6100) ^{*2}
Continuous operating time ^{*3}	Lithium ion battery unit: Approx. 28 hours Dry battery unit: Approx. 8 hours (at 25 °C, no alarm, no lighting)
Operating temperature range	-20 °C to +50 °C (no sudden fluctuations)
Operating humidity range ^{*4}	0 to 95 %RH (no condensation)
Operating pressure range	80 kPa to 120 kPa (80 kPa to 110 kPa for explosion-proof range)
Structure	Dustproof/waterproof enclosure (IP67 equivalent) (excluding pipes)
Explosion-proof construction	Intrinsically safe explosion-proof construction, flame-proof enclosure

Item	Specifications
Explosion-proof class	Japan Ex (explosion-proof electrical equipment type certified) model: (with new ceramic type sensor) Ex da ia IIC T4 Ga (without new ceramic type sensor) Ex ia IIC T4 Ga ATEX model: (with new ceramic type sensor) II 1 G Ex da ia IIC T4 Ga (BUL-6100) II 1 G Ex da ia IIC T4 Ga (BUD-6100/Toshiba batteries) II 1 G Ex da ia IIC T3 Ga (BUD-6100/Duracell batteries) (without new ceramic type sensor) II 1 G Ex ia IIC T4 Ga (BUL-6100) II 1 G Ex ia IIC T4 Ga (BUD-6100/Toshiba batteries) II 1 G Ex ia IIC T3 Ga (BUD-6100/Duracell batteries) IECEx model: (with new ceramic type sensor) Ex da ia IIC T4 Ga (BUL-6100) Ex da ia IIC T4 Ga (BUD-6100/Toshiba batteries) Ex da ia IIC T3 Ga (BUD-6100/Duracell batteries) (without new ceramic type sensor) Ex ia IIC T4 Ga (BUL-6100) Ex ia IIC T4 Ga (BUD-6100/Toshiba batteries) Ex ia IIC T3 Ga (BUD-6100/Duracell batteries)
Certifications	CE marking
External dimensions	Approx. 70 (W) × 201 (H) × 56 (D) mm
Weight	Approx. 500 g (with BUL-6100), approx. 450 g (with BUD-6100)

*1: By default, the panic alarm and man down alarm settings are both disabled. The settings must be enabled if these alarms are required. (See '7-4 Man down alarm and panic alarm settings'.)

*2: Japan Ex model can use three Toshiba LR6T (JE) batteries.

ATEX/IECEx model can use either three Toshiba LR6T (JE) or three Duracell MN1500 batteries.

*3: For the six-gas specification with combustible gas (new ceramic type sensor, CH₄, %LEL), oxygen sensor, hydrogen sulfide sensor, carbon monoxide, VOC, and carbon dioxide sensor. The continuous operating time varies depending on the sensors installed.

*4: Operating humidity range: Varies depending on the sensor model, refer to '11-2 Sensor specifications'.

11-2 Sensor specifications

11-2-1 Combustible gas sensors



CAUTION

- Do not install different gas type sensors when using combustible gas sensors.
The new ceramic type sensor and thermal conductivity type sensor can be used in combination to detect the same gas type.
Quality cannot be guaranteed if sensors for different gas types are used in combination.

<New ceramic type>

Item	Detection target gas	Methane CH ₄	Isobutane HC (i-C ₄ H ₁₀)		
Sensor model	NCR-6309				
Explosion-proof specifications	Japan Ex	ATEX/IECEX	Japan Ex	ATEX/IECEX	
Display range	0 – 100 %LEL	0 – 100 %LEL	0 – 100 %LEL	0 – 100 %LEL	
Detection range	0 – 100 %LEL	0 – 100 %LEL	0 – 100 %LEL	0 – 100 %LEL	
Resolution	1 %LEL	1 %LEL	1 %LEL	1 %LEL	
Alarm setpoints	First alarm	10 %LEL	10 %LEL	10 %LEL	10 %LEL
	Second alarm	50 %LEL	25 %LEL	50 %LEL	25 %LEL
	Third alarm	50 %LEL	50 %LEL	50 %LEL	50 %LEL
	TWA	-	-	-	-
	STEL	-	-	-	-
OVER	100 %LEL	100 %LEL	100 %LEL	100 %LEL	
Operating temperature range	-20 °C to +50 °C (no sudden fluctuations)				
Operating humidity range	10 to 90 %RH (no condensation)				

* At temperatures below approximately -10 °C, isobutane (HC (i-C₄H₁₀)) gas may liquefy.



CAUTION

(1) Operating environment precautions

- Note that if a new ceramic type combustible gas sensor is used in an environment where silicone compounds, halides, high-concentration sulfides, or high-concentration solvent gases are present, sensor life may be reduced, sensitivity to combustible gases may deteriorate, and accurate readings may not be obtained.
If use in such environments is unavoidable, use for the shortest possible time and allow the product to suck in fresh air afterward. Confirm that the reading returns to normal and is stabilized.
- Readings will be given even for combustible gases other than the detection target gas.
- Some interference may occur in environments where gases with high thermal conductivity such as carbon dioxide (CO₂), argon (Ar), and helium (He) are present in high concentrations as base gases.

- For measurements performed in locations where high-concentration combustible gases are known to be present, select [VOL ONLY] for the new ceramic type combustible gas sensor (NCR sensor) and thermal conductivity type combustible gas sensor (TE sensor) range settings. (See '6-4-1 Setting the combustible gas sensor range'.)
- With high oxygen concentrations, contact with high-concentration gas of 100 %LEL or more may damage the sensor.

(2) Gas adjustment precautions

- In user mode, contact with high-concentration gas of 100 %LEL or more will damage the sensor.
- If the sensors have been in contact with nitrogen (N₂) or high-concentration gas, exhaust for at least five minutes before performing gas adjustment.
- Allow the product to warm up for at least 10 minutes in air before performing fresh air adjustment and span adjustment.

(3) General operation precautions

- The detection target gas must be specified at the time of ordering.
- If no oxygen sensor is installed and the product comes into contact with high-concentration gas of 100 %LEL or more, an OVER alarm will occur and remain until it is reset. (See '4-3 Gas alarm patterns'.)
- If the oxygen concentration drops below 10 %, the combustible gas concentration reading for the new ceramic type combustible gas sensor (NCR sensor) will appear as [----], and if the combustible gas sensor range setting is set to [AUTO RANGE] (default setting), the display changes to the thermal conductivity type combustible gas sensor (TE sensor) reading. Note that, if [LEL ONLY] is set, the display does not change automatically. (See '6-4-1 Setting the combustible gas sensor range'.)
- If the oxygen sensor (ESR-X13P) is not installed or if the combustible gas sensor range is set to [LEL ONLY], the OVER alarm will remain fixed if the measured combustible gas concentration exceeds 100 %LEL. (See '6-4-1 Setting the combustible gas sensor range'.)
- To reset the alarm, press the RESET button in the presence of fresh air. The concentration display resumes a short while after pressing the RESET button.
- When oxygen concentrations fall, the readings may also fall.
- The product cannot be used at oxygen concentrations of 10 % or lower.
- Perform fresh air adjustment and span adjustment if the zero point has fluctuated.
- When low vapor pressure gases are measured by aspiration, the gas may condense when aspirated from warmer areas and measured in cooler areas, or blockages may occur in sintered alloy. Keep vapor pressure in mind when using the product.
- If the temperature fluctuates by $\pm 40^{\circ}\text{C}$ or more in the atmosphere where fresh air adjustment and span adjustment have been performed, indication accuracy may deteriorate. If this occurs, repeat adjustment.
- Readings may fluctuate if the product is subject to strong external impact or vibration. If this occurs, perform fresh air adjustment and span adjustment.
- Readings may be lower due to condensation when the product is moved suddenly from room temperature to high-temperature high-humidity conditions.
- The sensor may be hot during replacement. Be careful to avoid burns when replacing the sensor. If the sensor is hot, turn off the power and wait for it to cool.

NOTE

- ▶ The alarm setpoints indicated in the table above can be changed. However, the setpoint cannot be changed for those shown as "-".
-

<Thermal conductivity type>

Item	Detection target gas	Methane CH ₄
Sensor model		TE-7561
Explosion-proof specifications		Japan Ex and ATEX/IECEX
Display range		0 – 100 vol%
Detection range		0 – 100 vol%
Resolution		1 vol%
Alarm setpoints	First alarm	-
	Second alarm	-
	Third alarm	-
	TWA	-
	STEL	-
	OVER	100 vol%
Operating temperature range		-20 °C to +50 °C (no sudden fluctuations)
Operating humidity range		0 to 95 %RH (no condensation)

**CAUTION****(1) Operating environment precautions**

- The presence of high concentrations of organic gases, alcohol, etc. may damage the sensor. Repeat adjustment if the zero point has fluctuated.
- In addition to the detection target gas, the sensor also reacts to gases whose thermal conductivity differs significantly from that of clean air.
- Readings may fluctuate if the product is subject to strong external impact or vibration. If this occurs, perform fresh air adjustment and span adjustment.

(2) Gas adjustment precautions

- Use nitrogen (N₂) base calibration gas for gas adjustment.

(3) General operation precautions

- The detection target gas must be specified at the time of ordering.
- If a new ceramic type combustible gas sensor (NCR sensor) is installed and the range setting for the combustible gas sensor is [AUTO RANGE] (default setting), the reading will be displayed for the new ceramic type combustible gas sensor (NCR sensor). When the gas concentration exceeds 100 %LEL, the product switches to the thermal conductivity type combustible gas sensor (TE sensor), and the measurement reading switches to the thermal conductivity type combustible gas sensor (TE sensor) value in vol%.

NOTE

- ▶ The alarm setpoints indicated in the table above can be changed. However, the setpoint cannot be changed for those shown as “-”.

<Non-dispersive infrared type (NDIR)>

Item	Detection target gas	Methane CH ₄	Isobutane HC (i-C ₄ H ₁₀)*
Sensor model		DES-3311-3	DES-3311-2
Explosion-proof specifications		Japan Ex and ATEX/IECEx	Japan Ex and ATEX/IECEx
Display range		0 – 100 %LEL/ 100 %LEL – 100.0 vol%	0 – 100 %LEL/ 100 %LEL – 30.0 vol%
Detection range		0 – 100 %LEL/ 100 %LEL – 100.0 vol%	0 – 100 %LEL
Resolution		1 %LEL/0.5 vol%	1 %LEL/0.5 vol%
Alarm setpoints	First alarm	10 %LEL	10 %LEL
	Second alarm	50 %LEL	50 %LEL
	Third alarm	50 %LEL	50 %LEL
	TWA	-	-
	STEL	-	-
	OVER	100.0 vol%	30.0 vol%
Operating temperature range		-20 °C to +50 °C (no sudden fluctuations)	
Operating humidity range		0 to 95 %RH (no condensation)	

* At temperatures below approximately -10 °C, isobutane (HC (i-C₄H₁₀)) gas may liquefy.

**CAUTION**

- Allow the product to warm up for at least 10 minutes before performing fresh air adjustment and span adjustment.
- Ensure identical temperatures, humidity, and pressure in the gas adjustment and measurement environments. The reading may fluctuate due to the temperature, humidity, and pressure characteristics.
- Interference occurs due to hydrocarbons other than the target gas.
- If the composition of the base gas differs greatly for gas adjustment and measurement—for example, if an air base is used for gas adjustment but a carbon dioxide base is used for measurement—readings may differ due to infrared adsorption characteristics, even if the concentration of the target gas is the same.

NOTE

- ▶ The alarm setpoints indicated in the table above can be changed. However, the setpoint cannot be changed for those shown as “-”.
- ▶ The display automatically switches to vol% when detection target gas is detected at 100 %LEL or above.

<Hot-wire semiconductor type>

Item	Detection target gas	Methane CH ₄	Isobutane HC (i-C ₄ H ₁₀)*
Sensor model		SHS-8661	SHS-8661
Explosion-proof specifications		Japan Ex and ATEX/IECEX	Japan Ex and ATEX/IECEX
Display range		0 – 5,000 ppm	0 – 2,000 ppm
Detection range		0 – 2,000 ppm	0 – 500 ppm
Resolution		10 ppm	10 ppm
Alarm setpoints	First alarm	-	-
	Second alarm	-	-
	Third alarm	-	-
	TWA	-	-
	STEL	-	-
	OVER	5,000 ppm	2,000 ppm
Operating temperature range		-20 °C to +50 °C** (no sudden fluctuations)	
Operating humidity range		20 to 95 %RH (no condensation)	

* At temperatures below approximately -10 °C, isobutane (HC (i-C₄H₁₀)) gas may liquefy.

** Absolute humidity not exceeding 46 g/m³ (equivalent to 37 °C, 95 %RH)

**CAUTION****(1) Operating environment precautions**

- Some interference may occur when highly thermally conductive gases such as CO₂, Ar, and He are present in high concentrations as base gases.
- The zero point may rise if the temperature or humidity fluctuates with respect to the ambient temperature at which fresh air adjustment or span adjustment was performed. If this occurs, perform fresh air adjustment.
- Note that if a hot-wire semiconductor type combustible gas sensor is used in an environment where silicone compounds, halides, high-concentration sulfides, or high-concentration solvent gases are present, sensor life may be reduced, sensitivity to combustible gases may deteriorate, and accurate readings may not be obtained.

If use in such environments is unavoidable, use for the shortest possible time and allow the product to suck in fresh air afterward. Confirm that the reading returns to normal and is stabilized.

- If low vapor pressure gases are detected by aspiration, the gas may condense when aspirated from warmer areas and detected in cooler areas, or blockages may occur in sintered alloy. Keep vapor pressure in mind when using the product.

(2) Gas adjustment precautions

- Prepare the calibration gas according to the humidity of the operating environment.
- Allow the product to warm up for at least 10 minutes in fresh air before performing fresh air adjustment and span adjustment.

(3) General operation precautions

- The reading may fluctuate due to the sensor reacting to combustible gases other than the detection target gas.
- When oxygen concentrations fall, the readings may also fall.
- Readings may fluctuate if the product is subject to strong external impact or vibration.

- The zero point may fluctuate if the sensor comes into contact with high-concentration gas continuously for extended periods. If this occurs, perform fresh air adjustment.
- If the temperature or humidity changes rapidly between the storage and usage locations, turn on the power and allow the product to stand and acclimatize for about 10 minutes in an environment similar to the usage location before performing fresh air adjustment in fresh air.
- A gas alarm may be triggered if the temperature or humidity varies. If this occurs, confirm that the surrounding atmosphere is filled with fresh air, then repeat fresh air adjustment in the measurement environment.

Example: If the product is turned on indoors at a temperature of 20 °C and humidity of 40 %RH and then taken outdoors (temperature 30 °C, humidity 60 %RH), an alarm will be issued due to the change in humidity. In cases like this, perform fresh air adjustment outdoors before starting measurement.

- The gas alarm may remain active following continuous contact with gas or after contact with high-concentration gas. If this occurs, draw in fresh air for at least five minutes, then repeat fresh air adjustment.
- The reading may freeze at a high value if the product is dropped or subjected to impact. If this occurs, perform fresh air adjustment in a location where there is fresh air.
- The warmup time will vary depending on the sensor stability.
- If the product has not been used for an extended period, it may take longer than normal to warm up or a sensor abnormality indication ([FAIL]) may appear. If this occurs, restart the product and be sure to perform fresh air adjustment.
- This product is intended for the detection of minute gas leaks, so gas concentration values are approximate.

NOTE

- ▶ The alarm setpoints indicated in the table above can be changed. However, the setpoint cannot be changed for those shown as "-".
-

11-2-2 Carbon dioxide sensors

<Non-dispersive infrared type (NDIR)>

Item	Detection target gas	Carbon dioxide CO ₂	Carbon dioxide CO ₂
Sensor model		DES-3311-4	DES-3311-1
Explosion-proof specifications		Japan Ex and ATEX/IECEX	Japan Ex and ATEX/IECEX
Display range		0 – 10,000 ppm	0 – 10.00 vol%
Detection range		0 – 10,000 ppm	0 – 5.00 vol%
Resolution		20 ppm	0.02 vol%
Alarm setpoints	First alarm	5,000 ppm	0.50 vol%
	Second alarm	OFF	3.00 vol%
	Third alarm	OFF	3.00 vol%
	TWA	5,000 ppm	0.50 vol%
	STEL	OFF	3.00 vol%
	OVER	10,000 ppm	10.00 vol%
Operating temperature range		-20 °C to +50 °C (no sudden fluctuations)	
Operating humidity range		0 to 95 %RH (no condensation)	

**CAUTION**

- Allow the product to warm up for at least 10 minutes before performing CO₂ zero adjustment and span adjustment.
- Ensure identical temperatures, humidity, and pressure in the gas adjustment and measurement environments. The reading may fluctuate due to the temperature, humidity, and pressure characteristics.
- If the composition of the base gas differs greatly for gas adjustment and measurement—for example, if an air base is used for gas adjustment but an argon base is used for measurement—readings may differ due to infrared adsorption characteristics, even if the concentration of the target gas is the same.

NOTE

- ▶ The alarm setpoints (including "OFF") indicated in the table above can be changed. However, the setpoint cannot be changed for those shown as "-".

11-2-3 Oxygen sensor

<Electrochemical type>

Item	Detection target gas	Oxygen O ₂	
Sensor model		ESR-X13P	
Explosion-proof specifications		Japan Ex	ATEX/IECEX
Display range		0 – 40.0 %	0 – 40.0 %
Detection range		0 – 25.0 %	0 – 25.0 %
Resolution		0.1 %	0.1 %
Alarm setpoints	First alarm	19.5 %	19.5 %
	Second alarm	18.0 %	18.0 %
	Third alarm	25.0 %	23.5 %
	TWA	-	-
	STEL	-	-
	OVER	40.0 %	40.0 %
Operating temperature range		-20 °C to +50 °C (no sudden fluctuations)	
Operating humidity range		10 to 90 %RH (no condensation)	

**CAUTION**

- The electrolyte consists of sulfuric acid. Do not attempt to disassemble the sensor.
- Each sensor has a specified installation position on the main unit. Sensors will not function correctly if installed in the wrong location or not properly oriented. Applying excessive force to install sensors may damage the sensor and main unit. This may also cause the sensors to fail.
- The label indicating the gas name also constitutes an important part. Do not allow the label to become damaged or dirty. Using while damaged may prevent the product from sampling gas correctly.
- Do not press or peel off the silver label affixed to the sensor. Doing so may result in measurement performance that falls short of specifications.
- Do not use any gas other than nitrogen (N₂) as the balance gas for gas adjustment. Otherwise, reading errors will increase, preventing accurate measurement.
- Do not expose to sudden pressure fluctuations. The reading will fluctuate briefly, preventing accurate measurement.
- Do not subject the sampling tube or other pipes to positive or negative pressure. Applying pressure may cause the reading to fluctuate and trigger an alarm. If the reading changes, remove any pressure applied before resuming use.

NOTE

- ▶ The alarm setpoints indicated in the table above can be changed. However, the setpoint cannot be changed for those shown as “-”.

11-2-4 Toxic gas sensors

<Electrochemical type (ESR sensors)>

Item	Detection target gas	Hydrogen sulfide H ₂ S		Carbon monoxide CO	
Sensor model		ESR-A1DP			
Explosion-proof specifications		Japan Ex	ATEX/IECEX	Japan Ex	ATEX/IECEX
Display range		0 – 200.0 ppm	0 – 200.0 ppm	0 – 2,000 ppm	0 – 2,000 ppm
Detection range		0 – 30.0 ppm	0 – 100.0 ppm	0 – 500 ppm	0 – 500 ppm
Resolution		0.1 ppm	0.1 ppm	1 ppm	1 ppm
Alarm setpoints	First alarm	1.0 ppm	5.0 ppm	25 ppm	25 ppm
	Second alarm	10.0 ppm	30.0 ppm	50 ppm	50 ppm
	Third alarm	10.0 ppm	100.0 ppm	50 ppm	1,200 ppm
	TWA	1.0 ppm	1.0 ppm	25 ppm	25 ppm
	STEL	5.0 ppm	5.0 ppm	200 ppm	200 ppm
	OVER	200.0 ppm	200.0 ppm	2,000 ppm	2,000 ppm
Operating temperature range		-20 °C to +50 °C (no sudden fluctuations)			
Operating humidity range		10 to 90 %RH (no condensation)			

Item	Detection target gas	Hydrogen sulfide H ₂ S		Carbon monoxide CO	
Sensor model		ESR-A13i		ESR-A1CP/ESR-A13P	
Explosion-proof specifications		Japan Ex	ATEX/IECEX	Japan Ex	ATEX/IECEX
Display range		0 – 200.0 ppm	0 – 200.0 ppm	0 – 2,000 ppm	0 – 2,000 ppm
Detection range		0 – 30.0 ppm	0 – 100.0 ppm	0 – 500 ppm	0 – 500 ppm
Resolution		0.1 ppm	0.1 ppm	1 ppm	1 ppm
Alarm setpoints	First alarm	1.0 ppm	5.0 ppm	25 ppm	25 ppm
	Second alarm	10.0 ppm	30.0 ppm	50 ppm	50 ppm
	Third alarm	10.0 ppm	100.0 ppm	50 ppm	1200 ppm
	TWA	1.0 ppm	1.0 ppm	25 ppm	25 ppm
	STEL	5.0 ppm	5.0 ppm	200 ppm	200 ppm
	OVER	200.0 ppm	200.0 ppm	2,000 ppm	2,000 ppm
Operating temperature range		-20 °C to +50 °C (no sudden fluctuations)			
Operating humidity range		10 to 90 %RH (no condensation)			

**CAUTION**

- The electrolyte consists of sulfuric acid. Do not attempt to disassemble the sensor.
- Each sensor has a specified installation position on the main unit. Sensors will not function correctly if installed in the wrong location or not properly oriented. Applying excessive force to install sensors may damage the sensor and main unit. This may also cause the sensors to fail.
- The label indicating the gas name also constitutes an important part. Do not allow the label to become damaged or dirty. Using while damaged may prevent the product from sampling gas correctly.

<ESR-A1DP>

- A humidity control filter and activated carbon filter must be fitted when this sensor is used. The effects of humidity and interference gases will increase the possibility of false alarms.
- Condensation or the presence of significant moisture in the humidity control filter will significantly impair gas sensitivity. If the air drawn in exceeds the range for operating temperature and humidity and may result in condensation within the internal piping, draw in fresh air and confirm that the gas sensitivity is normal before resuming use.
- The activated carbon filter has a finite service life. If the reading varies significantly from when new, even when used in the same way, the filter is life expired. Replace the filter.

<ESR-A13i>

- A humidity control filter must be fitted when this sensor is used. The effects of humidity will increase the possibility of false alarms.
- Condensation or the presence of significant moisture in the humidity control filter will significantly impair gas sensitivity. If the air drawn in exceeds the range for operating temperature and humidity and may result in condensation within the internal piping, draw in fresh air and confirm that the gas sensitivity is normal before resuming use.

<ESR-A1CP/ESR-A13P>

- An activated carbon filter must be fitted when this sensor is used. The effects of interference gases will increase the possibility of false alarms.
- The activated carbon filter has a finite service life. If the reading varies significantly from when new, even when used in the same way, the filter is life expired. Replace the filter.

NOTE

- ▶ The ESR-A1DP is a dual sensor capable of detecting both carbon monoxide and hydrogen sulfide with a single sensor.
- ▶ The ESR-A1CP includes a correction function to reduce hydrogen interference. This function works for hydrogen concentrations up to 2,000 ppm. However, if used in environments exceeding 40 °C for more than 15 minutes, it may be affected by hydrogen interference and indicate a higher concentration than the actual carbon monoxide level.
- ▶ The alarm setpoints indicated in the table above can be changed.

<Electrochemical type (smart sensors)>

Item	Detection target gas	Sulfur dioxide SO ₂	Nitrogen dioxide NO ₂	Hydrogen cyanide HCN	Phosphine PH ₃
Sensor model		ESS-03DH	ESS-03DH	ESS-03DH	ESS-03DH
Explosion-proof specifications		Japan Ex and ATEX/IECEX	Japan Ex and ATEX/IECEX	Japan Ex and ATEX/IECEX	Japan Ex and ATEX/IECEX
Display range		0 – 99.90 ppm	0 – 20.00 ppm	0 – 15.0 ppm	0 – 20.00 ppm
Detection range		0 – 99.90 ppm	0 – 20.00 ppm	0 – 15.0 ppm	0 – 1.00 ppm
Resolution		0.05 ppm	0.05 ppm	0.1 ppm	0.01 ppm
Alarm setpoints	First alarm	2.00 ppm	3.00 ppm	5.0 ppm	0.30 ppm
	Second alarm	5.00 ppm	6.00 ppm	10.0 ppm	1.00 ppm
	Third alarm	5.00 ppm	6.00 ppm	10.0 ppm	1.00 ppm
	TWA	2.00 ppm	3.00 ppm	OFF	0.30 ppm
	STEL	5.00 ppm	OFF	4.7 ppm	1.00 ppm
OVER	99.90 ppm	20.00 ppm	15.0 ppm	20.00 ppm	
Operating temperature range	-20 °C to +50 °C (no sudden fluctuations)				
Operating humidity range	10 to 90 %RH (no condensation)				

Item	Detection target gas	Ammonia NH ₃	Chlorine Cl ₂
Sensor model		ESS-B332	ESS-B335
Explosion-proof specifications		Japan Ex and ATEX/IECEX	Japan Ex and ATEX/IECEX
Display range		0 – 400.0 ppm	0 – 10.00 ppm
Detection range		0 – 400.0 ppm	0 – 10.00 ppm
Resolution		0.5 ppm	0.05 ppm
Alarm setpoints	First alarm	25.0 ppm	0.50 ppm
	Second alarm	50.0 ppm	1.00 ppm
	Third alarm	50.0 ppm	1.00 ppm
	TWA	25.0 ppm	0.50 ppm
	STEL	35.0 ppm	1.00 ppm
OVER	400.0 ppm	10.00 ppm	
Operating temperature range	-20 °C to +50 °C (no sudden fluctuations)		
Operating humidity range	20 to 90 %RH (no condensation)		

**CAUTION**

- Never disassemble the sensor. The sulfur dioxide, nitrogen dioxide, hydrogen cyanide, and phosphine sensors in particular use sulfuric acid as the electrolyte, and are dangerous if disassembled.
- The sensor will not operate if installed in the wrong direction. Forcibly installing the sensor may damage the sensor and main unit. This may also cause the sensor to fail.

NOTE

- ▶ Due to export restrictions, hydrogen cyanide sensors indicate concentrations of 0.0 – 0.2 ppm as 0.0 ppm for both Japan Ex and ATEX/IECEX models.
- ▶ The alarm setpoints indicated in the table above can be changed.

11-2-5 VOC sensors

<Photoionization type (PID)>

Item	Detection target gas	Volatile organic compounds VOCs	Volatile organic compounds VOCs	Volatile organic compounds VOCs
Sensor model		PIS-001A	PIS-002A	PIS-003
Photoionization energy		10.6 eV	10.6 eV	10.0 eV
Explosion-proof specifications		Japan Ex and ATEX/IECEX	Japan Ex and ATEX/IECEX	Japan Ex and ATEX/IECEX
Display range		0 – 40,000 ppb	0 – 4,000 ppm	VOC: 0 – 100.0 ppm Benzene: 0 – 50.0 ppm*
Detection range		0 – 40,000 ppb	0 – 4,000 ppm	VOC: 0 – 100.0 ppm Benzene: 0 – 50.0 ppm*
Resolution		1 ppb (0 – 4,000 ppb) 10 ppb (4,000 – 40,000 ppb)	0.1 ppm (0 – 400.0 ppm) 1 ppm (400 – 4,000 ppm)	0.01 ppm (0 – 10.00 ppm) 0.1 ppm (10.0 – 100.0 ppm)
Alarm setpoints	First alarm	5,000 ppb	400.0 ppm	5.00 ppm
	Second alarm	10,000 ppb	1,000 ppm	10.0 ppm
	Third alarm	10,000 ppb	1,000 ppm	10.0 ppm
	TWA	OFF	OFF	OFF
	STEL	OFF	OFF	OFF
	OVER	40,000 ppb	4,000 ppm	100.0 ppm
Operating temperature range	-20 °C to +50 °C (no sudden fluctuations)			
Operating humidity range	0 to 95 %RH (no condensation)			

*Display range and detection range for the benzene select mode

**CAUTION**

- If the VOC sensor is exposed to high concentrations of methane (CH₄), ethane (C₂H₆), propane (C₃H₈), or other gases, [----] may appear on the concentration display, the LEDs may flash, and the buzzer may sound, temporarily disabling measurement. In environments where these gases are present, even if the concentration display does not indicate [----], be aware that the VOC concentration may not be accurately measured. Even if the VOC sensor concentration display indicates [----], other unaffected sensors can continue measurement.

<Example interference gases causing [----] to be displayed in the VOC sensor concentration display area>

Interference gas	Concentration
Methane (CH ₄)	6 vol% or more
Ethane(C ₂ H ₆)	80 vol% or more
Propane (C ₃ H ₈)	90 vol% or more

NOTE

- The alarm setpoints indicated in the table above can be changed.

12

Appendix

12-1 Data logger function

The product is equipped with a data logger function that records measurement results and events such as gas alarms, fault alarms, and gas adjustment.

NOTE

- ▶ The data logger management program sold separately is required to check data recorded using the data logger function. Contact RIKEN KEIKI for more information.

The data logger provides the following five functions:

(1) Interval trend

Records the changes in measured concentration from the start of measurement until the power is turned off. The average value, minimum and maximum values, and times of minimum and maximum occurrences are recorded for all gases, regardless of alarm type.

The 3,600 most recent data items are recorded.

If the number of items exceeds 3,600, the oldest data will be overwritten by the latest data.

However, if the maximum recording time is exceeded, the oldest data will be deleted before reaching 3,600.

The maximum recording times corresponding to different intervals are as follows:

Interval	10 seconds	20 seconds	30 seconds	1 minute	3 minutes	5 minutes	10 minutes
Maximum recording time	10 hours	20 hours	30 hours	60 hours	180 hours	300 hours	600 hours

The standard interval is 5 minutes.

The interval can be set using the data logger management program sold separately.

(2) Alarm trend

When an alarm is triggered, this function records the changes in measured concentration for 30 minutes before and after the alarm occurred (one hour in total).

Alarm trend records peak values (minimum values for oxygen) over 5-second periods at 5-second intervals.

The eight most recent data items are recorded.

If the number of items exceeds 8, the oldest data will be overwritten by the latest data.

(3) Alarm event

Records alarm occurrences as events.

This function records the time the alarm was triggered, the detection target gas, and the type of alarm event.

The 100 most recent events are recorded.

If the number of items exceeds 100, the oldest data will be overwritten by the latest data.

(4) Trouble event

Records fault alarm occurrences as events.

This function records the time when the fault alarm was triggered, the detection target gas, device information, and the type of trouble event.

The 100 most recent events are recorded.

If the number of items exceeds 100, the oldest data will be overwritten by the latest data.

(5) Adjustment history

Records data when adjustment is performed.

Records the adjustment time and concentrations before and after adjustment.

The 100 most recent adjustment history data items are recorded.

If the number of items exceeds 100, the oldest data will be overwritten by the latest data.

NOTE

- ▶ Communication mode starts automatically if the infrared communication port of the product is positioned where IrDA communication is available while the date and time or battery voltage are displayed after the power is turned on. To enter communication mode, press the SHIFT/▼ and DISP buttons simultaneously while the date and time or battery voltage is displayed at startup.
 - ▶ A fault alarm will be triggered if no communication connection can be confirmed for a preset duration in communication mode. If this occurs, either repeat the communication connection or turn off the power for the product.
-

12-2 100 %LEL conversion list

The following table shows the standard conversion for 100 %LEL and ppm. The 100 %LEL values are standard values for both Japan Ex and ATEX/IECEx models.

Gas type		Standard	IEC ^{*6}	ISO ^{*7}
Methane	CH ₄	50,000 ppm ^{*2}	44,000 ppm	44,000 ppm
Isobutane	HC (i-C ₄ H ₁₀)	18,000 ppm ^{*3}	13,000 ppm	15,000 ppm
Hydrogen	H ₂	40,000 ppm ^{*2}	40,000 ppm	40,000 ppm
Methanol	CH ₃ OH	55,000 ppm ^{*1}	60,000 ppm	60,000 ppm
Acetylene	C ₂ H ₂	15,000 ppm ^{*1}	23,000 ppm	23,000 ppm
Ethylene	C ₂ H ₄	27,000 ppm ^{*2}	23,000 ppm	24,000 ppm
Ethane	C ₂ H ₆	30,000 ppm ^{*2}	24,000 ppm	24,000 ppm
Ethanol	C ₂ H ₅ OH	33,000 ppm ^{*2}	31,000 ppm	31,000 ppm
Propylene	C ₃ H ₆	20,000 ppm ^{*2}	20,000 ppm	18,000 ppm
Acetone	C ₃ H ₆ O	21,500 ppm ^{*1}	25,000 ppm	25,000 ppm
Propane	C ₃ H ₈	20,000 ppm ^{*1}	17,000 ppm	17,000 ppm
Butadiene	C ₄ H ₆	11,000 ppm ^{*1}	14,000 ppm	14,000 ppm
Cyclopentane	C ₅ H ₁₀	14,000 ppm ^{*4}	14,000 ppm	14,000 ppm
Benzene	C ₆ H ₆	12,000 ppm ^{*1}	12,000 ppm	12,000 ppm
N-hexane	n-C ₆ H ₁₄	12,000 ppm ^{*1}	10,000 ppm	10,000 ppm
Toluene	C ₇ H ₈	12,000 ppm ^{*2}	10,000 ppm	10,000 ppm
N-heptane	n-C ₇ H ₁₆	11,000 ppm ^{*2}	8,500 ppm	8,000 ppm
Xylene	C ₈ H ₁₀	10,000 ppm ^{*2}	10,000 ppm	10,000 ppm
N-nonane	n-C ₉ H ₂₀	7,000 ppm ^{*5}	7,000 ppm	7,000 ppm
Ethyl acetate	EtAc	21,000 ppm ^{*1}	20,000 ppm	20,000 ppm
Isopropyl alcohol	IPA	20,000 ppm ^{*2}	20,000 ppm	20,000 ppm
Methyl ethyl ketone	MEK	18,000 ppm ^{*2}	15,000 ppm	15,000 ppm
Methyl methacrylate	MMA	17,000 ppm ^{*2}	17,000 ppm	17,000 ppm
Dimethyl ether	DME	30,000 ppm ^{*1}	27,000 ppm	27,000 ppm
Methyl isobutyl ketone	MIBK	12,000 ppm ^{*3}	12,000 ppm	12,000 ppm
Tetrahydrofuran	THF	20,000 ppm ^{*2}	15,000 ppm	15,000 ppm
N-pentane	n-C ₅ H ₁₂	15,000 ppm ^{*2}	11,000 ppm	11,000 ppm

*1 Recommended Practices for Explosion-Protected Electrical Installations in General Industries (NIIS/1985)

*2 Recommended Practices for Explosion-Protected Electrical Installations in General Industries (NIIS/2006)

*3 Technical recommendations of the Research Institute of Industrial Safety (NIIS/1994)

*4 Chemical Safety Management Data Book (The Chemical Daily Co., Ltd.)

*5 Product Safety Data Sheet (Eishin Kagaku Co., Ltd.)

*6 IEC values comply with EN 60079-20-1:2010.

*7 ISO values comply with ISO 10156:2017.

12-3 Zero suppression function

Gas sensors are affected by environmental factors such as temperature and humidity. They are also substantially affected by the interference of the detection target gas. Environmental and interference effects may cause the product reading to fluctuate around zero.

The zero suppression function is designed to suppress notifications of reading fluctuations around zero. The function suppresses reading fluctuations below the set value and displays zero instead (or 20.9 % for an oxygen sensor).

NOTE

- ▶ The default setting is enabled. To disable the setting, use the MT-GX-6100 configuration program and refer to the operating manual. If the setting is disabled, readings may fluctuate due to output variations attributable to sensor characteristics.
- ▶ Even when enabled, the zero suppression function will function only in measurement mode and display mode.
- ▶ All readings in the range from zero to the negative suppression value indicated in the following table are suppressed. Values from the negative suppression value to the M OVER value will be displayed, but accurate measurements cannot be achieved in this state. Fresh air adjustment should be performed. For information on M OVER values, see '4-2 Gas alarm setpoints'.
- ▶ Suppression is not applied with the thermal conductivity type sensor (TE sensor) even when the suppression function is enabled in the configuration program.
- ▶ Due to export restrictions, hydrogen cyanide sensors indicate concentrations of 0.0 – 0.2 ppm as 0.0 ppm for both Japan Ex and ATEX/IECEX models, regardless of the suppression function setting.

The zero suppression function settings are as follows:

Sensor	Detection target gas	suppression value	Suppression type	Negative suppression value	Negative suppression type
NCR-6309	Methane (CH ₄) Isobutane (HC (i-C ₄ H ₁₀))	2 %LEL	Smoothing	-5 %LEL	Cut-off
ESR-X13P	Oxygen (O ₂)	20.9 % ± 0.5 % (20.4 – 21.4 %)	Smoothing	-0.5 %	Cut-off
ESR-A13i	Hydrogen sulfide (H ₂ S)	0.3 ppm	Cut-off	-1.5 ppm	Cut-off
ESR-A1DP	Hydrogen sulfide (H ₂ S)	0.3 ppm	Cut-off	-1.5 ppm	Cut-off
ESR-A1DP	Carbon monoxide (CO)	2 ppm	Cut-off	-25 ppm	Cut-off
ESR-A13P	Carbon monoxide (CO)	2 ppm	Cut-off	-25 ppm	Cut-off
ESR-A1CP	Carbon monoxide (CO)	2 ppm	Cut-off	-25 ppm	Cut-off
PIS-001A	Volatile organic compounds (VOC, 10.6 eV, ppb)	N/A	N/A	-200 ppb	Cut-off
PIS-002A	Volatile organic compounds (VOC, 10.6 eV, ppm)	N/A	N/A	-20.0 ppm	Cut-off
PIS-003	Volatile organic compounds (VOC, 10.0 eV, ppm)	N/A	N/A	-0.50 ppm	Cut-off
DES-3311-2	Isobutane (HC (i-C ₄ H ₁₀))	2 %LEL	Smoothing	-5 %LEL	Cut-off
DES-3311-3	Methane (CH ₄)	2 %LEL	Smoothing	-5 %LEL	Cut-off
DES-3311-1	Carbon dioxide (CO ₂ , vol%)	N/A	N/A	-0.5 vol%	Cut-off
DES-3311-4	Carbon dioxide (CO ₂ , ppm)	N/A	N/A	-500 ppm	Cut-off
ESS-03DH	Sulfur dioxide (SO ₂)	0.10 ppm	Smoothing	-4.99 ppm	Cut-off
ESS-03DH	Nitrogen dioxide (NO ₂)	0.15 ppm	Smoothing	-1.00 ppm	Cut-off
ESS-03DH	Hydrogen cyanide (HCN)	N/A	N/A	-0.7 ppm	Cut-off
ESS-03DH	Phosphine (PH ₃)	0.02 ppm	Smoothing	-0.25 ppm	Cut-off
ESS-B332	Ammonia (NH ₃)	2.0 ppm	Smoothing	-20.0 ppm	Cut-off
ESS-B335	Chlorine (Cl ₂)	0.20 ppm	Smoothing	-0.50 ppm	Cut-off
SHS-8661	Isobutane (HC (i-C ₄ H ₁₀))	N/A	N/A	-100 ppm	Cut-off
SHS-8661	Methane (CH ₄)	N/A	N/A	-250 ppm	Cut-off

12-4 Zero follower function

The zero points for the sensors used in the product may fluctuate when used for extended periods.

The zero follower function stabilizes the zero point by adjusting reading fluctuations at the zero point that result from extended periods of use.

New ceramic type combustible gas sensor	The sensor output is tracked to zero the value if output fluctuations occur below the stipulated value when the power is turned on.
Sensors other than new ceramic type combustible gas sensor	The sensor output is tracked to zero the value if the sensor output repeatedly drops below zero when the power is turned on.

* The zero follower function is enabled when the power is turned on.

NOTE

- ▶ The default setting is enabled. To disable the setting, use the MT-GX-6100 configuration program and refer to the operating manual. When the setting is disabled, the zero point may fluctuate due to output variation caused by the sensor characteristics.
- ▶ The zero follower function is disabled for the oxygen sensor and thermal conductivity type combustible gas sensor (TE sensor).

12-5 List of interference gases for electrochemical type sensors

This is a list of interference gases for electrochemical type oxygen and toxic gas sensors.

The values indicated here are representative values measured in a laboratory environment using new sensors and filters. Note that the condition of the sensors and filters and environmental factors at the site such as temperature and humidity will affect susceptibility to interference. These figures may differ from the actual values. Use them as reference values to identify the presence of interference gases and the degree of interference influence.



CAUTION

- A false alarm may occur with measurements performed in an environment where strong interference gases are present.

<ESR-X13P (O₂)>

Gas name	Chemical formula	Gas concentration	Reading
Hydrogen	H ₂	2 vol%	-2.8 % O ₂
Carbon monoxide	CO	2,980 ppm	0.2 % O ₂
Sulfur dioxide	SO ₂	1,010 ppm	0.3 % O ₂
Hydrogen sulfide	H ₂ S	292 ppm	0.1 % O ₂
Methane	CH ₄	50 vol%	-0.03 % O ₂
Isobutane	HC (i-C ₄ H ₁₀)	50 vol%	-0.14 % O ₂

<ESR-A13i (H₂S)>

Gas name	Chemical formula	Gas concentration	Reading
Sulfur dioxide	SO ₂	25.0 ppm	0.0 ppm
Ammonia	NH ₃	38.6 ppm	0.0 ppm
Chlorine	Cl ₂	2.0 ppm	0.0 ppm
Methane	CH ₄	1.26 vol%	0.0 ppm
Isobutane	HC (i-C ₄ H ₁₀)	0.45 vol%	0.0 ppm
Isobutylene	C ₄ H ₈	1,000 ppm	0.1 ppm

<ESR-A13P (CO)>

Gas name	Chemical formula	Gas concentration	Reading
Hydrogen	H ₂	100 ppm	11 ppm
Sulfur dioxide	SO ₂	30 ppm	0 ppm
Hydrogen sulfide	H ₂ S	30 ppm	0 ppm
Hydrogen cyanide	HCN	1.8 ppm	-1 ppm
Ammonia	NH ₃	255 ppm	1 ppm
Chlorine	Cl ₂	0.8 ppm	0 ppm
Methane	CH ₄	1.25 vol%	0 ppm
Isobutane	HC (i-C ₄ H ₁₀)	0.45 vol%	-1 ppm

<ESR-A1CP (CO)>

Gas name	Chemical formula	Gas concentration	Reading
Hydrogen	H ₂	500 ppm	7 ppm
Sulfur dioxide	SO ₂	25.0 ppm	1 ppm
Hydrogen sulfide	H ₂ S	24.2 ppm	0 ppm
Ammonia	NH ₃	38.6 ppm	0 ppm
Chlorine	Cl ₂	2.0 ppm	-1 ppm
Phosphine	PH ₃	2.51 ppm	3 ppm
Nitrogen dioxide	NO ₂	50.5 ppm	0 ppm
Methane	CH ₄	1.26 vol%	1 ppm
Isobutane	HC (i-C ₄ H ₁₀)	0.45 vol%	0 ppm
Isobutylene	C ₄ H ₈	1,000 ppm	3 ppm
Carbon dioxide	CO ₂	20.0 vol%	0 ppm

<ESR-A1DP (CO)>

Gas name	Chemical formula	Gas concentration	Reading
Hydrogen	H ₂	100 ppm	17 ppm
Sulfur dioxide	SO ₂	30 ppm	3 ppm
Hydrogen sulfide	H ₂ S	30 ppm	2 ppm
Ammonia	NH ₃	255 ppm	2 ppm
Chlorine	Cl ₂	0.8 ppm	-1 ppm
Phosphine	PH ₃	2.5 ppm	3 ppm
Nitrogen dioxide	NO ₂	50.5 ppm	1 ppm
Methane	CH ₄	1.25 vol%	-1 ppm
Isobutane	HC (i-C ₄ H ₁₀)	0.45 vol%	0 ppm
Isobutylene	C ₄ H ₈	1,000 ppm	9 ppm
Carbon dioxide	CO ₂	100 vol%	8 ppm

<ESR-A1DP (H₂S)>

Gas name	Chemical formula	Gas concentration	Reading
Hydrogen	H ₂	2,000 ppm	1.3 ppm
Sulfur dioxide	SO ₂	30 ppm	-0.1 ppm
Carbon monoxide	CO	1,000 ppm	2.6 ppm
Ammonia	NH ₃	250 ppm	-0.1 ppm
Chlorine	Cl ₂	0.8 ppm	-0.1 ppm
Phosphine	PH ₃	2.5 ppm	1.5 ppm
Nitrogen dioxide	NO ₂	50.5 ppm	-4.6 ppm
Methane	CH ₄	1.25 vol%	-0.1 ppm
Isobutane	HC (i-C ₄ H ₁₀)	0.45 vol%	-0.1 ppm
Isobutylene	C ₄ H ₈	1,000 ppm	0.1 ppm
Carbon dioxide	CO ₂	100 vol%	-0.1 ppm

<ESS-03DH (SO₂)>

Gas name	Chemical formula	Gas concentration	Reading
Hydrogen	H ₂	2,000 ppm	3.4 ppm
Hydrogen sulfide	H ₂ S	100 ppm	0.0 ppm
Carbon monoxide	CO	500 ppm	2.3 ppm
Ammonia	NH ₃	75 ppm	0.0 ppm
Chlorine	Cl ₂	2 ppm	0.0 ppm
Phosphine	PH ₃	0.5 ppm	0.0 ppm
Nitrogen dioxide	NO ₂	9 ppm	-10.4 ppm
Hydrogen cyanide	HCN	6.2 ppm	0.0 ppm

<ESS-03DH (NO₂)>

Gas name	Chemical formula	Gas concentration	Reading
Hydrogen	H ₂	2,000 ppm	-0.3 ppm
Sulfur dioxide	SO ₂	6 ppm	-3.8 ppm
Hydrogen sulfide	H ₂ S	100 ppm	0.0 ppm
Carbon monoxide	CO	500 ppm	-2.0 ppm
Ammonia	NH ₃	75 ppm	0.0 ppm
Chlorine	Cl ₂	2 ppm	0.0 ppm
Phosphine	PH ₃	0.5 ppm	0.0 ppm
Hydrogen cyanide	HCN	6.2 ppm	0.0 ppm

<ESS-03DH (HCN)>

Gas name	Chemical formula	Gas concentration	Reading
Hydrogen	H ₂	2,000 ppm	4.7 ppm
Sulfur dioxide	SO ₂	6 ppm	11.4 ppm
Hydrogen sulfide	H ₂ S	100 ppm	225 ppm
Carbon monoxide	CO	500 ppm	1.1 ppm
Ammonia	NH ₃	75 ppm	0.3 ppm
Chlorine	Cl ₂	2 ppm	-2.0 ppm
Phosphine	PH ₃	0.5 ppm	4.9 ppm
Nitrogen dioxide	NO ₂	9 ppm	-20.8 ppm

<ESS-B332 (NH₃)>

Gas name	Chemical formula	Gas concentration	Reading
Hydrogen	H ₂	2,000 ppm	0 ppm
Sulfur dioxide	SO ₂	6 ppm	-3.5 ppm
Hydrogen sulfide	H ₂ S	100 ppm	-32 ppm
Carbon monoxide	CO	500 ppm	0 ppm
Chlorine	Cl ₂	0.8 ppm	-1.4 ppm
Phosphine	PH ₃	0.5 ppm	0 ppm
Nitrogen dioxide	NO ₂	9 ppm	-5.7 ppm
Hydrogen cyanide	HCN	7.8 ppm	-1.3 ppm

<ESS-03DH (PH₃)>

Gas name	Chemical formula	Gas concentration	Reading
Hydrogen	H ₂	2,000 ppm	0.53 ppm
Nitrogen dioxide	SO ₂	6 ppm	1.29 ppm
Hydrogen sulfide	H ₂ S	100 ppm	25.4 ppm
Carbon monoxide	CO	500 ppm	0.12 ppm
Ammonia	NH ₃	75 ppm	0.03 ppm
Chlorine	Cl ₂	2 ppm	-0.23 ppm
Nitrogen dioxide	NO ₂	9 ppm	-2.35 ppm

12-6 Radio law certification

This product is certified as complying with radio laws in individual countries and regions as follows.

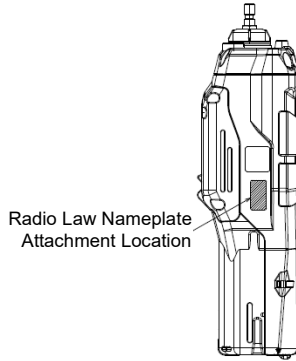

The following actions are prohibited by radio laws. The user and/or retailer may be subject to punishment if prohibited actions are committed.

- Use in countries or regions in which radio law certification has not been obtained
- Sale in countries or regions in which radio law certification has not been obtained
- Disassembly or modification of the product
- Removal of certification labels from the product

If this product is used aboard marine vessels, the radio laws of the country bordering the territorial waters shall apply. In such cases, use shall be prohibited in countries or regions in which radio law certification has not been obtained.

Check to confirm that industrial, scientific, and medical equipment (e.g., microwave ovens), on-premises radio stations for mobile identification used in plant manufacturing lines (radio stations requiring a license), and specified low-power radio stations are not operated in the frequency band (2.4 GHz) used by the product. If the product causes radio interference to a radio station for mobile identification, take measures to eliminate radio interference—for example, using the product in a different location or stopping radio emissions.

Wireless specifications

Wireless communication	Protocol: Bluetooth Low Energy Version: Ver. 4.2 Frequency: 2,402 MHz to 2,480 MHz Modulation: FSK Output: Maximum 6 dBm
------------------------	--------------------------------------------------------------------------------------------------------------------------------------

Radio law certification (Country/region)	Description
Radio Act (Japan)	This product contains radio equipment certified to comply with technical standards in accordance with the Radio Act. Accordingly, a radio station license is not required when using this product.
	 R 001-A07864 Construction design certification number: 001-A07864 Wireless frequency: 2,402 MHz to 2,480 MHz Maximum wireless output: 6 dBm

RE Directive (EU countries)	 <p>We declare that this equipment complies with the basic requirements of Directive 2014/53/EU and other relevant provisions. Connect to the network with radio waves of frequency 2.4 GHz band and maximum output 6 dBm.</p>
FCC compliance (United States)	<p>This device complies with part 15 of the FCC Rules. Operation is subject to the following two conditions: (1) This device may not cause harmful interference, and (2) this device must accept any interference received, including interference that may cause undesired operation.</p> <p>FCC CAUTION Changes or modifications not expressly approved by the party responsible for compliance could void the user's authority to operate the equipment.</p> <p>Note: This equipment has been tested and found to comply with the limits for a Class A digital device, pursuant to part 15 of the FCC Rules. These limits are designed to provide reasonable protection against harmful interference when the equipment is operated in a commercial environment. This equipment generates, uses, and can radiate radio frequency energy and, if not installed and used in accordance with the instruction manual, may cause harmful interference to radio communications. Operation of this equipment in a residential area is likely to cause harmful interference in which case the user will be required to correct the interference at his own expense.</p> <p>This equipment complies with FCC radiation exposure limits set forth for an uncontrolled environment and meets the FCC radio frequency (RF) Exposure Guidelines. This equipment has very low levels of RF energy that is deemed to comply without testing of specific absorption rate (SAR).</p>
IC compliance (Canada)	<p>This device complies with Industry Canada's license-exempt RSSs. Operation is subject to the following two conditions: This device may not cause interference; and This device must accept any interference, including interference that may cause undesired operation of the device.</p> <p>Le présent appareil est conforme aux CNR d'Industrie Canada applicables aux appareils radio exempts de licence. L'exploitation est autorisée aux deux conditions suivantes: l'appareil ne doit pas produire de brouillage; l'utilisateur de l'appareil doit accepter tout brouillage radioélectrique subi, même si le brouillage est susceptible d'en compromettre le fonctionnement.</p> <p>This equipment complies with IC radiation exposure limits set forth for an uncontrolled environment and meets RSS-102 of the IC radio frequency (RF) Exposure rules. This equipment has very low levels of RF energy that is deemed to comply without testing of specific absorption rate (SAR).</p> <p>Cet équipement est conforme aux limites d'exposition aux rayonnements énoncées pour un environnement non contrôlé et respecte les règles d'exposition aux fréquences radioélectriques (RF) CNR-102 de l'IC. Cet équipement émet une énergie RF très faible qui est considérée comme conforme sans évaluation du débit d'absorption spécifique (DAS).</p>

KCC
(KOREA)



Identification code: R-R-GD5-GX-6100_RIKEN
 Compliance approval applicant: RIKEN KEIKI Co., Ltd.
 Product name: Portable Gas Detector
 Model: GX-6100
 Manufacturer: RIKEN KEIKI Co., Ltd.
 Country of manufacture: Japan

Class A device (broadcast communication device for business use)
 This product is a radio wave transmitting device for business use (Class A), and is intended for use in non-household locations. Retailers and users must pay attention to this point.

A급 기기 (업무용 방송통신기자재)

이 기기는 업무용(A급) 전자파적합기기로서 판매자 또는 사용자는 이 점을 주의하시기 바라며, 가정외의 지역에서 사용하는 것을 목적으로 합니다.

12-7 Warranty policy

RIKEN KEIKI CO., LTD. (RIKEN) warrants the product to be free from defects in material and workmanship under normal use and service for a period of the number of years to be listed in "Table: List of warranty years", beginning on the date of shipment to the buyer. This warranty extends only to the sale of new and unused products to the original buyer. RIKEN's warranty obligation is limited, at RIKEN's option, to repair or replacement of a defective product that is returned to a RIKEN KEIKI Quality control center located in Japan within the warranty period. In no event shall RIKEN's liability hereunder exceed the purchase price actually paid by the buyer for the Product.

This warranty does not include:

- a) fuses, disposable batteries or the routine replacement of parts due to the normal wear and tear of the product arising from use;
- b) any product which in RIKEN's opinion, has been misused, altered, neglected or damaged, by accident or abnormal conditions of operation, handling or use;
- c) any damage or defects attributable to repair of the product by any person other than an authorized dealer, or the installation of unapproved parts on the product; or

The obligations set forth in this warranty are conditional on:

- a) proper storage, installation, calibration, use, maintenance and compliance with the product manual instructions and any other applicable recommendations of RIKEN;
- b) the buyer promptly notifying RIKEN of any defect and, if required, promptly making the product available for correction. No goods shall be returned to RIKEN until receipt by the buyer of shipping instructions from RIKEN; and
- c) the right of RIKEN to require that the buyer provide proof of purchase such as the original invoice, bill of sale or packing slip to establish that the product is within the warranty period.

THE BUYER AGREES THAT THIS WARRANTY IS THE BUYER'S SOLE AND EXCLUSIVE REMEDY AND IS IN LIEU OF ALL OTHER WARRANTIES, EXPRESS OR IMPLIED, INCLUDING BUT NOT LIMITED TO ANY IMPLIED WARRANTY OF MERCHANTABILITY OR FITNESS FOR A PARTICULAR PURPOSE. RIKEN SHALL NOT BE LIABLE FOR ANY SPECIAL, INDIRECT, INCIDENTAL, OR BASED ON CONTRACT, TORT OR RELIANCE OR ANY OTHER THEORY.

Since some countries or states do not allow limitation of the term of an implied warranty, or exclusion or limitation of incidental or consequential damages, the limitations and exclusions of this warranty may not apply to every buyer. If any provision of this warranty is held invalid or unenforceable by a court of competent jurisdiction, such holding will not affect the validity or enforceability of any other provision.

Contacting RIKEN KEIKI

Email us at: intdept@rikenkeiki.co.jp

Visit RIKEN KEIKI website at: <https://www.rikenkeiki.com/>

JAPAN: +81-3-3966-1113

< Table: List of warranty years >

Product warranty		
1 year		
Sensor warranty		
Sensor model	Detection target gas	Warranty period
NCR-6309	Isobutane (HC (i-C ₄ H ₁₀)) [%LEL]	3 years
NCR-6309	Methane (CH ₄) [%LEL]	3 years
ESR-X13P	Oxygen (O ₂)	3 years
ESR-A1DP	Hydrogen sulfide (H ₂ S)/carbon monoxide (CO)	3 years
ESR-A13i	Hydrogen sulfide (H ₂ S)	3 years
ESR-A1CP	Carbon monoxide (CO)	3 years
ESR-A13P	Carbon monoxide (CO)	3 years
TE-7561	Methane (CH ₄) [vol%]	1 year
DES-3311-2	Isobutane (HC (i-C ₄ H ₁₀)) [%LEL/vol%]	1 year
DES-3311-3	Methane (CH ₄) [%LEL/vol%]	1 year
DES-3311-1	Carbon dioxide (CO ₂) [vol%]	1 year
DES-3311-4	Carbon dioxide (CO ₂) [ppm]	1 year
ESS-03DH	Sulfur dioxide (SO ₂)	1 year
ESS-03DH	Nitrogen dioxide (NO ₂)	1 year
ESS-03DH	Hydrogen cyanide (HCN)	1 year
ESS-B332	Ammonia (NH ₃)	1 year
ESS-B335	Chlorine (Cl ₂)	1 year
ESS-03DH	Phosphine (PH ₃)	1 year
PIS-001A	Volatile organic compounds (VOC, 10.6 eV) [ppb]	1 year
PIS-002A	Volatile organic compounds (VOC, 10.6 eV) [ppm]	1 year
PIS-003	Volatile organic compounds (VOC, 10.0 eV) [ppm]	1 year
SHS-8661	Isobutane (HC (i-C ₄ H ₁₀)) [ppm]	1 year
SHS-8661	Methane (CH ₄) [ppm]	1 year

Revision history

Issue	Revision details	Issue date
0	First issue (PT0-2521)	May, 7, 2025
1	Correction of a clerical error	June, 2, 2025
2	8-2-1 Preparation for gas adjustment corrected, 8-6-1 Periodic replacement parts corrected, 9-3 Product disposal corrected, CE declaration deleted	September, 30,2025
3	12-6 KCC (KOREA) added	May, 19 2026