



Combustible Gas Detection Alarm System

GP-148

Operating Manual

RIKEN KEIKI Co., Ltd.

2-7-6 Azusawa, Itabashi-ku, Tokyo, 174-8744, Japan

Phone : +81-3-3966-1113

Fax : +81-3-3558-9110

E-mail : intdept@rikenkeiki.co.jp

Web site : <https://www.rikenkeiki.co.jp/>

Contents

1. Product Overview	4
1-1. Introduction	4
1-2. Intended use	4
1-3. DANGER, WARNING, CAUTION, and NOTE	4
2. Important Safety Information	5
2-1. Danger items	5
2-2. Warnings.....	5
2-3. Precautions.....	6
3. Product Functions	7
3-1. Exterior drawings.....	7
3-2. Device configuration and names	8
3-3. Mounting diagram	10
3-4. Part names and functions	11
3-4-1. Base unit (buzzer).....	11
3-4-2. Indicator unit (same applied to base unit indicator).....	12
3-5. Block diagram	13
4. Usage Instructions.....	14
4-1. Usage note	14
4-2. Precautions regarding installation location	14
4-3. System design precautions.....	15
4-4. Grounding	18
4-5. Installation procedure	19
4-5-1. Wall mounting installation procedure	19
4-5-2. Rack mounting installation procedure	20
4-6. Device connection	21
4-6-1. Power supply connection	21
4-6-2. Connecting to contact outputs.....	21
4-6-3. Connecting to the 0 - 6 - 12 V DC output	21
4-7. Wiring	22
5. Operation Method.....	24
5-1. Preparations for startup	24
5-2. Basic operating procedures	24
5-3. Startup procedure	25
5-4. Detection mode	26
5-4-1. Display operations	26
5-4-2. External output (general alarm output voltage) operation	28
5-4-3. Alarm test.....	28
5-4-4. Alarm setpoint confirmation.....	29
5-5. Check mode	30
5-5-1. Check mode procedures.....	30
5-6. UPS operation (* for UPS-equipped models).....	32
5-6-1. Functions	32
5-6-2. Display and operations	32
5-6-3. UPS operation settings	33
5-7. Shutdown procedure.....	33
6. Operations and Functions	34
6-1. Gas alarm pattern	34
6-2. Fault alarm pattern.....	35
6-3. Gas alarms caused other than by gas detection.....	36
6-4. Functions	36

6-5. Operations when setting flame detector (option) connection	38
7. Maintenance	39
7-1. Maintenance intervals and items	39
7-2. User mode	40
7-3. Maintenance mode	41
8. Storage, Relocation, and Disposal	61
8-1. Procedure for storage or for extended periods without use	61
8-2. Procedures for relocation or reuse.....	61
8-3. Product disposal	61
9. Troubleshooting	62
10. Product Specifications	64
10-1. Specifications	64
10-2. Accessory list.....	67
11. Terminology	68
* Appendix Power consumption calculation method and UPS operating time quick referral table	69

1. Product Overview

1-1. Introduction

Thank you for purchasing this GP-148 Combustible Gas Detection Alarm System.

Please confirm that the model number of the product you purchased corresponds to the specifications described in this manual.

This operating manual describes the operating procedures and specifications for the product. It provides essential information to ensure correct use of the product. We recommend that both first-time users and those with previous experience with the product carefully read this manual to confirm their understanding of specific information and to refresh their familiarity with the product.

Keep this operating manual on hand to allow ready reference during use.

The contents of this manual are subject to change without notice to allow product improvements. Any duplication or reproduction of this manual without permission is prohibited, whether in whole or in part.

RIKEN KEIKI accepts no liability for accidents or damage resulting from use of the product, whether within or outside the warranty period.

1-2. Intended use



- This product is a combustible gas detection alarm system designed for use in detectors based on combustible gas sensors.
- This product is a safety device, and is not an analyzer or concentration meter designed for quantitative/qualitative gas analysis or measurement. Use the product correctly after confirming you fully understand its features and characteristics.
- The combustible gas detector connected to the indicator/alarm unit detects combustible gas leaking into the air.

The detected gas concentration is indicated on the character LCD (green/red bar meter display).

The indication varies depending on the danger level, with green indicating below the alarm setpoint and red indicating the alarm setpoint or over.

- This device incorporates two independent output gas alarm contacts (one-step gas alarm contact + one-step gas alarm contact or fault alarm contact).
- The base unit includes a general alarm contact, general alarm voltage output (0 - 6 - 12 V DC), external buzzer contact output, and 24 V DC (load: 10 mA or less) voltage output.
- This product can be used with an internal uninterruptible power system (UPS) battery to enable operation to continue during a power outage.
- This product can be used as an indicator for the 0 - 20 mA output by a specified flame detector. (Option)

1-3. DANGER, WARNING, CAUTION, and NOTE

 DANGER	This indicates that improper handling of the product may result in death, severe injury, or serious property damage.
 WARNING	This indicates that improper handling of the product may result in severe injury or serious property damage.
 CAUTION	The CAUTION symbol indicates that improper handling of the product may result in minor injury or minor property damage.
*NOTE	The NOTE sign indicates recommendations for product handling.

2. Important Safety Information

2-1. Danger items

DANGER

The product is a non-explosion-proof device.

2-2. Warnings

WARNING

- Specified devices
Do not connect detectors other than combustible gas detectors specified by RIKEN KEIKI to this product. There is a risk of damage to this product or the device being connected if devices other than RIKEN KEIKI devices are connected.
- Power supply
Before turning on the power for the product, be sure to confirm that the power supply voltage meets the specified voltage requirements.
Avoid using unstable power sources; doing so may lead to malfunctions.
- Protective grounding requirement
Do not cut the internal or external protective grounding cable of the product or disconnect the protective grounding terminal.
- Protective function defects
Check to confirm that there are no defects in the protective functions, such as the protective grounding and fuses. Do not operate the device if you suspect any potential defects in protective functions, such as the protective grounding.
- Fuse
Use a fuse of the specified rating (current, voltage, type) to prevent fire hazards.
Turn off the POWER switch and turn off the main power supply before replacing the fuse.
Do not use fuses other than the specified fuses or short-circuit the fuse holder.
- Operating in the presence of gases
Do not operate this product in locations where combustible or explosive gases or vapor is present. Operating this product in such environments is extremely hazardous.
- External connections
Be sure to provide secure protective grounding before connecting the product to the detection target or external control circuit.
- Internal maintenance
Be sure to turn off the switch on the power supply before replacing internal components (work involving opening the door).
- Action if a gas alarm occurs
An extreme hazard exists if gas is detected above the alarm setpoint. The user must take appropriate action based on the situation.

2-3. Precautions

CAUTION

- Do not use walkie-talkies near the product.
Radio waves from walkie-talkies or other radio transmitting devices near the product or cables may affect readings.
If you use walkie-talkies or other radio transmitters, use in areas where they will not affect the product.
- Wait at least five seconds after turning off the power before turning back on.
The product may not function correctly if the power is turned back on within five seconds.
- Do not use external output from the product to control other devices.
This product is not a control device. Never attempt to use the external output of the device to control other devices.
- Make sure adequate safety for the instrumentation can be maintained even if the power supply or signal cables are disconnected or malfunctions or faults occur.
- Note that the product may very occasionally be affected by electrical noise, static electricity, or electromagnetic noise.
The product is an electrical device. Provide protective measures before using the product in environments in which there is a possibility of electrical noise, static electricity, or electromagnetic noise.
- Do not modify the product or alter the settings unnecessarily.
Never attempt to disassemble or modify the product. Doing so will void product performance guarantees. Additionally, under certain circumstances, altering the settings unnecessarily without a proper understanding of the details may prevent the alarm from operating correctly. RIKEN KEIKI rejects all liability for any accidents arising from failure to observe the warnings indicated above. Use the product correctly in accordance with this operating manual.
- Be sure to perform regular maintenance.
The product, which is a safety device, and the detector must be regularly maintained to ensure safety.
- To clean the product, wipe gently with a dry cloth. Do not use organic solvents like alcohol or benzene, detergents or cleaners.
- Be sure to perform zero adjustment after turning the power back on again and after recovering from a power failure.

3. Product Functions

3-1. Exterior drawings

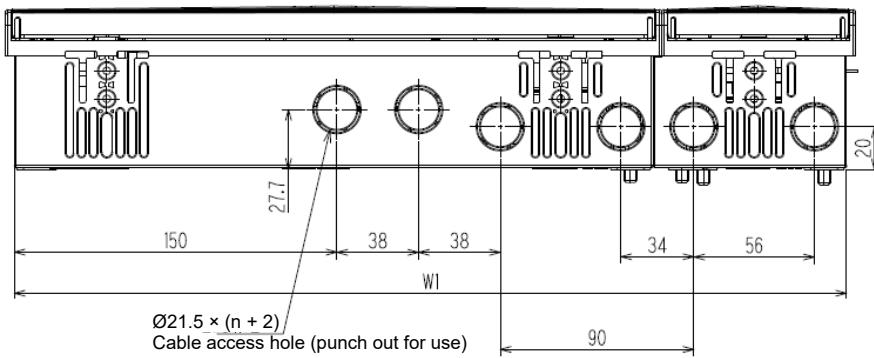
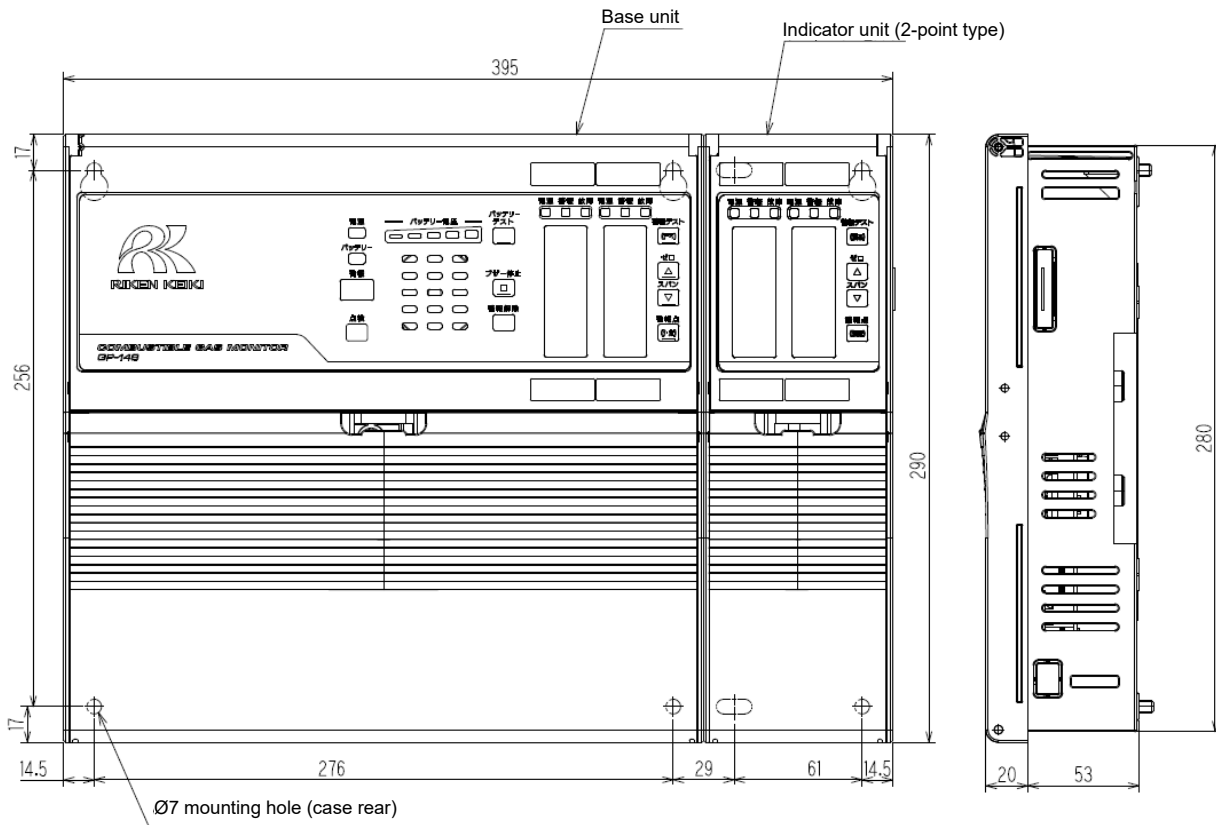

Number of points	W	W1	Mounting dimension	
			P1	P2
□	2	305	297	276
□	4	395	387	366
□	6	485	477	456
□	8	575	567	546
□	10	665	657	305 / 331
□	12	755	747	305 / 421

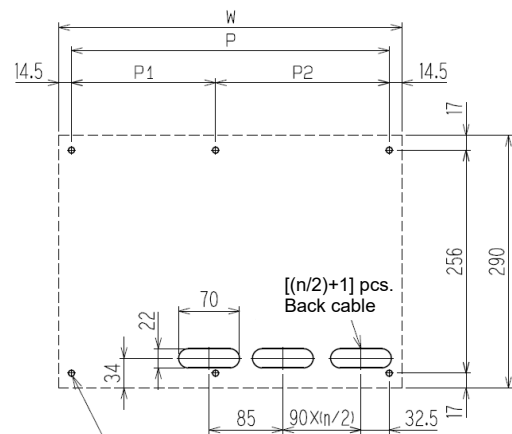

M6 or $\phi 7$
 2-8 points: 4pcs. 10-12 points: 6pcs

3-2. Device configuration and names

The product consists of a base unit and an indicator unit (for configuration of 4- or more point type)

The base unit consists of a buzzer and indicator (2-point type) and the indicator unit consists of an indicator (2-point type).

In addition to the indicator, the base unit includes a switching regulator and UPS (uninterruptible power system) battery*.

* For UPS-equipped models

<Appearance>

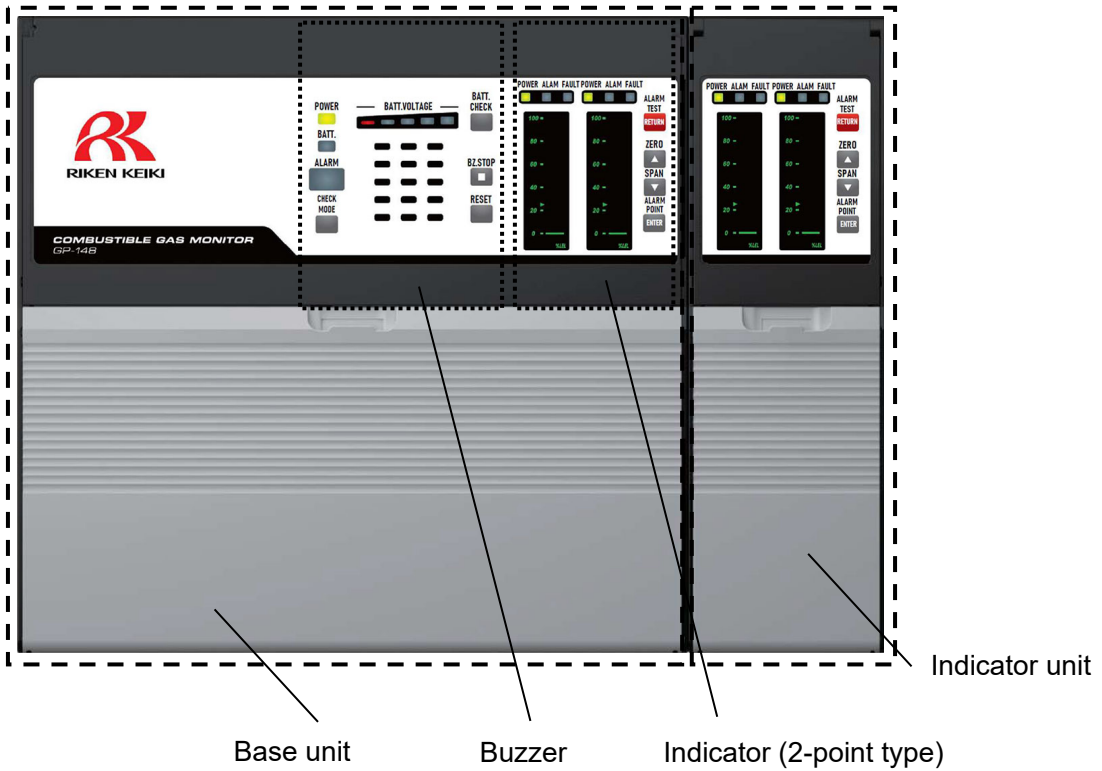

<Base unit interior>

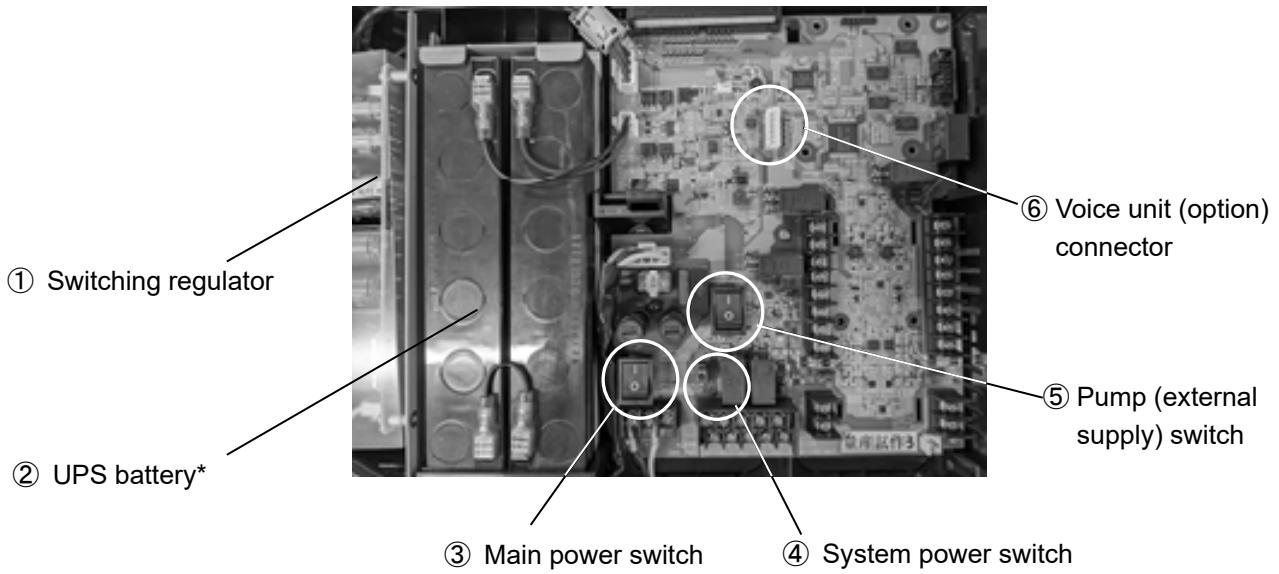

①	Switching regulator	Power supply unit generating a voltage of 24 V DC from the AC power supply
②	UPS battery*	Battery providing an uninterruptible power supply when the main power supply is unavailable due to power outage or other reasons*
③	Main power switch	Switch for turning the main power supply (AC power supply) on and off
④	System power switch	Switch for turning the GP-148 on
⑤	Pump (external supply) switch	Switch for turning on the power to the pump (or optional flame detector)
⑥	Voice unit connector	Connector for connecting to the optional voice unit

* For UPS-equipped models

3-3. Mounting diagram

Wall-mounted type

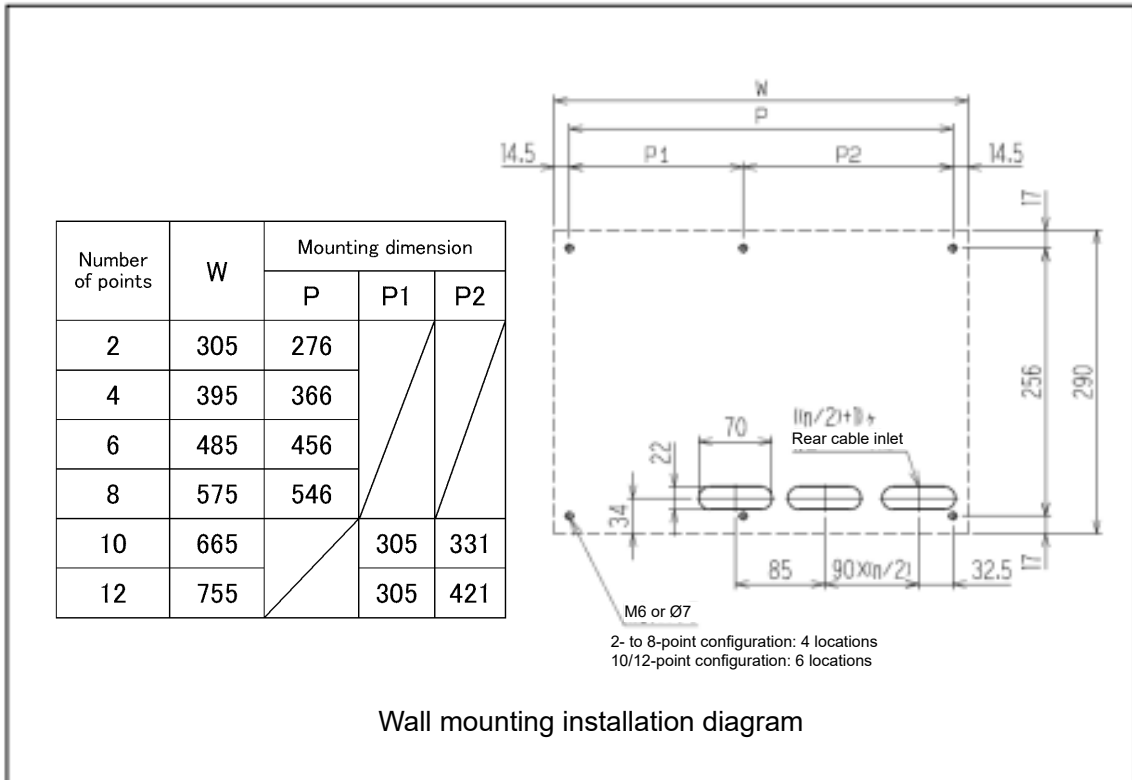

Rack-mounted type

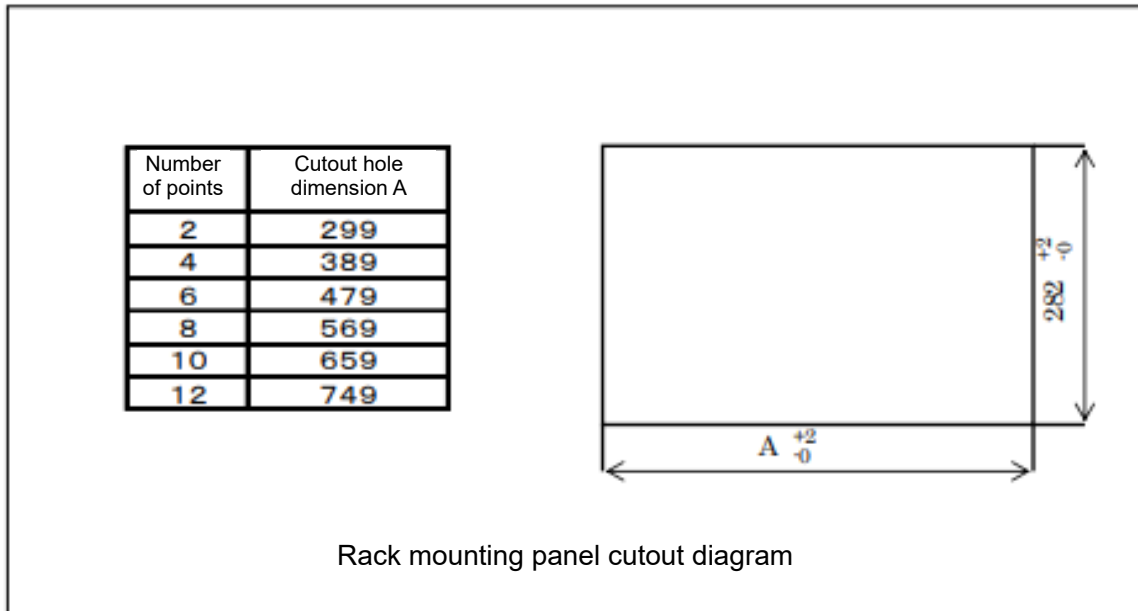

3-4. Part names and functions

3-4-1. Base unit (buzzer)

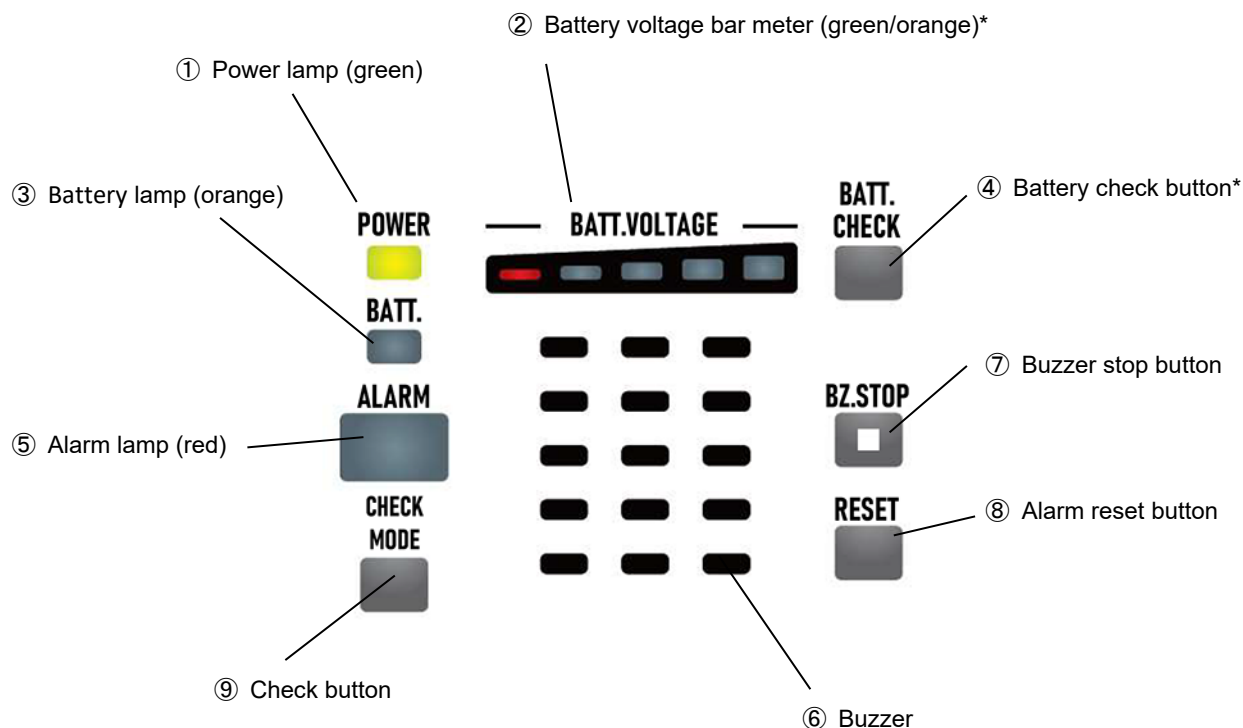

No. in figure	Name	Function
①	Power lamp (green)	This is the power lamp. Lights up during normal operation.
②	Battery voltage bar meter (green/orange)	Indicates the battery voltage level via a bar meter.*
③	Battery lamp (orange)	Lights up when the UPS is operating. Blinks during a battery discharge test.*
④	Battery check button	Used to perform a battery discharge test. Hold down to start. Hold down again to end.
⑤	Alarm lamp (red)	Lights up red when a gas alarm occurs. Goes out when the alarm is reset.
⑥	Buzzer	The buzzer sounds when an alarm or fault occurs.
⑦	Buzzer stop button	Silences the buzzer. Hold down the button when the buzzer is not sounding to sound the buzzer. Hold down while the buzzer is sounding to alter the volume level. (Three levels)
⑧	Alarm reset button	Press to reset the gas alarm pattern. If the alarm pattern is self-latching, press the reset button to switch from self-latching to auto-reset.
⑨	Check button	Hold down to select check mode. Hold down again to exit check mode and return to measurement mode.

* For UPS-equipped models

3-4-2. Indicator unit (same applied to base unit indicator)

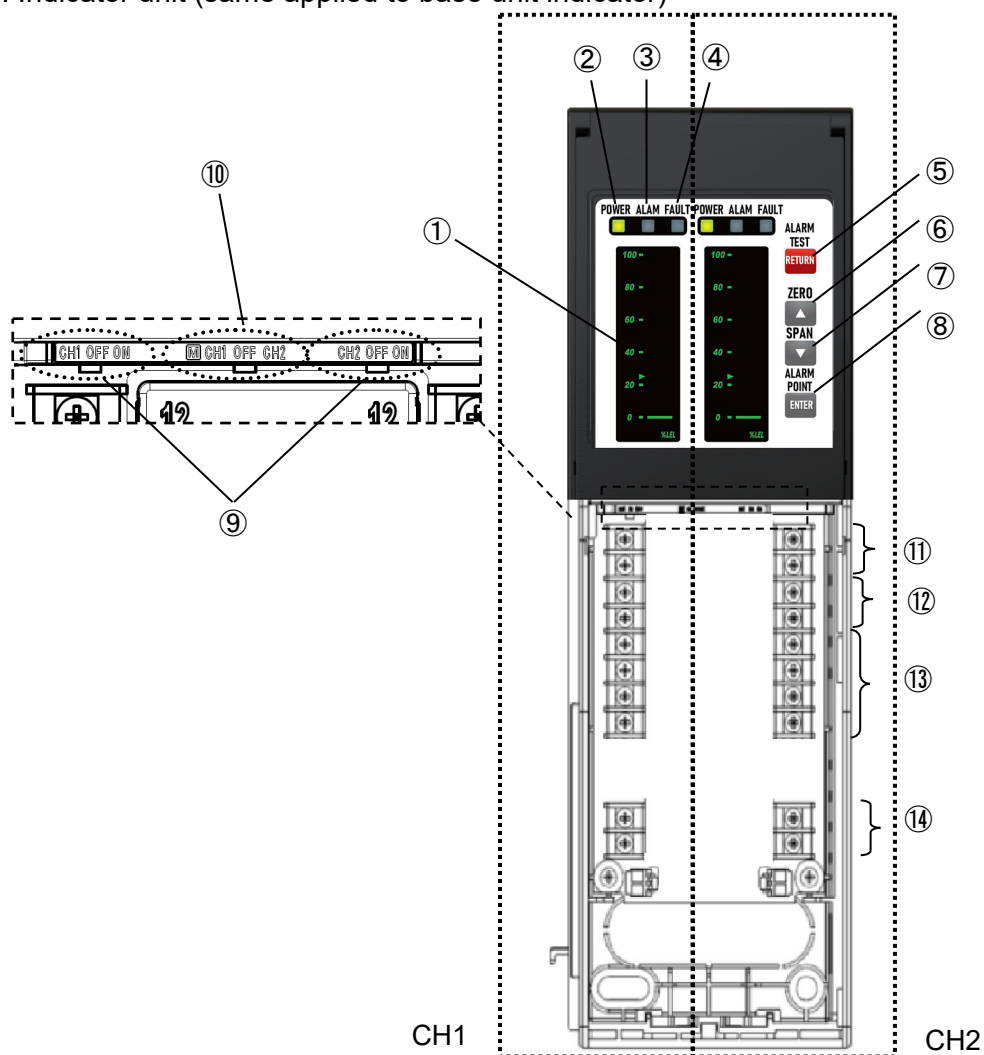

No. in figure	Name	Function
①	LCD display	Displays the gas concentration and status.
②	Power lamp	Lights up when the product is operating.
③	Alarm lamp	Lights up when a gas alarm occurs.
④	Fault lamp	Lights up when a fault occurs.
⑤	ALARM TEST/RETURN button	Used for maintenance. While being held down, a simulated full-scale concentration is produced. Used to return to the initial menu screen.
⑥	ZERO/▲ button	Used to start zero adjustment in check mode. Used to increment/decrement a menu number or setting in maintenance mode.
⑦	SPAN/▼ button	Used to start span adjustment in check mode. Used to increment/decrement a menu number or setting in maintenance mode.
⑧	ALARM POINT/ENTER button	ALARM POINT: Used to confirm alarm setpoints. ENTER: Used to confirm selection items in various modes.
⑨	Power switch	Power switches for CH1 and CH2
⑩	Selector switch	Selects the channel (left/right) to which button operations apply. The power lamp lights up orange when selected.
⑪	Individual alarm contact output 2	Can be used as gas alarm or fault alarm contacts. (Normally used as gas alarm contacts)
⑫	Individual alarm contact output 1	Can be used as gas alarm contacts.
⑬	Sensor terminals	Used to connect detectors.
⑭	Pump (external output) power supply	Power supply terminals for suction type detector pumps or flame detectors (option)

3-5. Block diagram

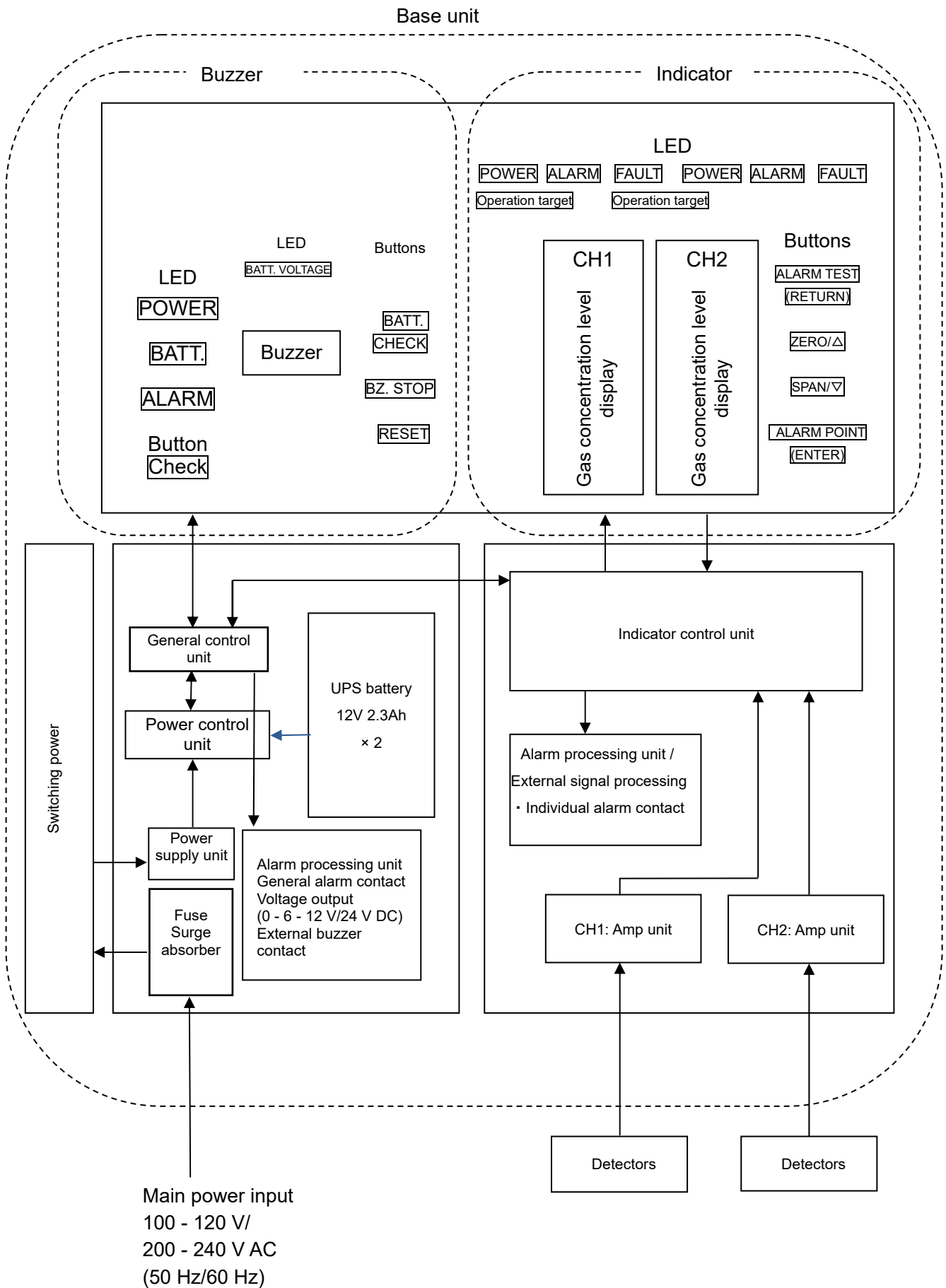

4. Usage Instructions

4-1. Usage note

The usage precautions apply to both users who have previously used the product and first-time users. Failure to observe these precautions may result in failure of the product and/or inability to detect gas correctly.

4-2. Precautions regarding installation location

CAUTION

- Do not install in locations exposed to direct sunlight or sudden temperature fluctuations. Avoid locations exposed to direct sunlight or radiant heat (infrared radiation from high-temperature bodies) and locations that may subject the product to sudden temperature fluctuations. Condensation may form inside the product.
- Do not install the product in locations where there is a risk of splashing water, oil, chemicals, or other liquids.
- Do not install in locations where temperatures can fall below -10 °C or exceed +50 °C. The operating temperature range for the product is -10 °C - +50 °C. Install in a stable location within the specified operating temperature range and free of sudden temperature fluctuations.
- Do not install the product in locations subject to vibration or impact. The product contains precision electronic components. Install the product in a stable location not exposed to vibration, impact, or risk of falling.
- Install away from noise-emitting devices (main unit and cables). Install the product away from locations with devices that may emit high frequencies.
 - Do not install next to devices that generate noise.
 - Do not lay cables parallel to each other.
 - Keep cables away from each other.
- Do not install the product in locations where the detection target gas accumulates. Do not install the product and detect in locations where the detection target gas accumulates.
- Do not install in locations where maintenance is dangerous or not possible. The product must be maintained regularly. Do not install within systems where the system must be stopped for maintenance; where part of the system must be detached to allow maintenance; where the product cannot be removed due to the presence of pipes or racks; or in other such locations. Do not install in locations where maintenance work would be hazardous (for example, due to the presence of high-voltage cables).
- Do not install in improperly grounded systems. When installing within a system, make sure the system is properly grounded.

4-3. System design precautions

 CAUTION
<p>An unstable power supply or noise may result in malfunctions or false alarms.</p> <p>The system in which this product is used must be designed in accordance with the information provided in this section.</p>

(1) Use a stable power source.

Note that the product's external output and alarm contacts may activate while the system stabilizes at power-on or in the event of an instantaneous power failure. In such cases, either use a UPS (uninterruptible power system) or take appropriate measures on the side receiving the power. Supply this product with a power source that meets the following requirements:

Power source voltage	100 - 120 V AC or 200 - 240 V AC, 50/60 Hz (voltage of main unit terminal)	
Time allowed for instantaneous power failures	Approx. 100 ms (without suction detector) (Power failures lasting longer than 100 ms will require restarting to recover.)	<u>Example of steps to take</u> Use an external uninterruptible power supply or similar system to guarantee continuous operation and functionality.
Miscellaneous	Do not use with power sources subject to very high power loads or high frequency noise.	<u>Example of steps to take</u> Where necessary, use a line filter or other device, and keep the product away from noise sources.

(2) Design accounting for heat dissipation.

If you plan to install the product in a closed instrument panel or similar space, install ventilation fans at the top and bottom of the panel.

(3) Lightning protection

<p>What is lightning surge?</p>	<p>Lightning hazards must be considered at factories or plants in cases of outdoor wiring or in cases of indoor wiring where an indoor cable is laid parallel to a cable drawn from outdoor wiring in the same duct. Lightning constitutes a massive emission source and cables act as receiving antennas, which can result in damage to devices connected to the cables. It is not possible to stop lightning from occurring. Additionally, note that inductive lightning surges due to lightning strikes cannot be entirely prevented, even if cables are installed in metal ducts or buried underground.</p>
<p>Lightning protection</p>	<p>While it is not possible to protect completely against disasters caused by lightning, the following protective measures can be taken: Take appropriate measures based on environmental conditions and the importance of the facility.</p> <ul style="list-style-type: none"> ▪ Connecting signal transmission paths via optical fibers ▪ Protection using lightning arrester (cable arrester) (A lightning arrester can be installed before the field devices and central processing equipment to protect against the possibility of inductive lightning surges transmitted through the cables. For usage details, contact the manufacturer of the lightning arrester.)
<p>Grounding</p>	<p>Surge noise is caused by lightning strikes and other factors. Devices must be grounded to protect against such noise sources.</p>

- * Lightning arresters include circuits that remove surge voltages that can damage field devices. Installing a lightning arrester may therefore attenuate signals.
 Perform an operation check before installing a lightning arrester.

(4) Alarm contacts

The alarm contacts on this product are designed to be used to transmit signals to activate external buzzers and alarm indicators.

Do not use for other purposes, such as for control purposes — for example, to control shutoff valves.

 CAUTION

A de-energized b contact (break contact) may cause a momentary open operation due to physical impact such as an external force. If a b contact is used as an alarm contact, implement measures to account for such momentary operations—for example, adding a delay operation (of approximately one second) to the signal on the b contact receiving side.

The alarm contact specifications of the product are described assuming resistance loads. If the alarm contacts use inductive loads, a reverse voltage will occur at the contacts, leading to the following potential problems:

- Relay contact sticking, insulation failure, contact failure
- Damage to electrical components due to high voltages occurring inside the product
- Malfunctions due to CPU runaway
- Whether due to an inductive load or not, unpredictable noise may occur at the contacts, possibly causing any of the faults described above.

⚠ CAUTION

- Do not normally use the alarm contacts of the product to operate inductive loads. (In particular, never use to operate devices such as fluorescent lamps or motors.)
- If operating inductive loads, link using an external relay (contact amplification). However, since the external relay coil also constitutes an inductive load, use a relay that runs on low voltage (less than 100 V AC) and a suitable surge protector (CR circuit, etc.) to protect the contacts of the product.

* Examples of inductive loads include the following:

- Signal towers, external relays, buzzers, sirens, fans, fluorescent lamps, motors

When operating a load, take appropriate measures referring to the following to stabilize the operation of the product and protect the alarm contacts.

- Use an external relay (low voltage, not exceeding 100 V AC) to link the circuits (contact amplification). Add a surge absorber (SK1) appropriate for the rating to the external relay.
- Also add a surge absorber (SK2) as necessary to the load side of the external relay.
- Depending on load conditions, it may be preferable to attach the surge absorber to the contact side. Check the load behavior to determine the optimal location.

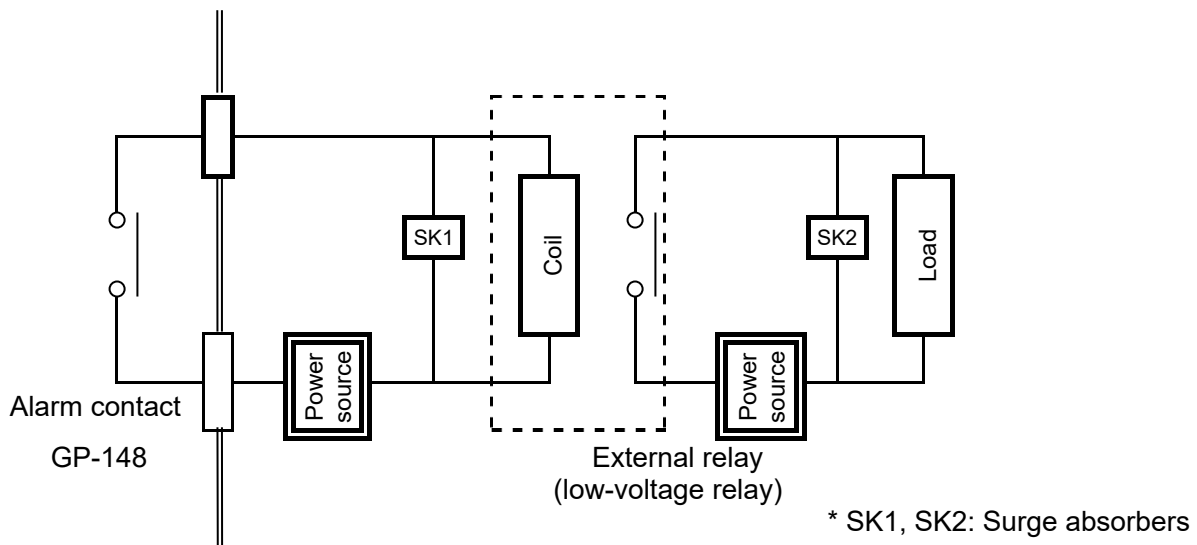



4-4. Grounding

Connect the grounding terminal  to the grounding terminal.

 **WARNING**

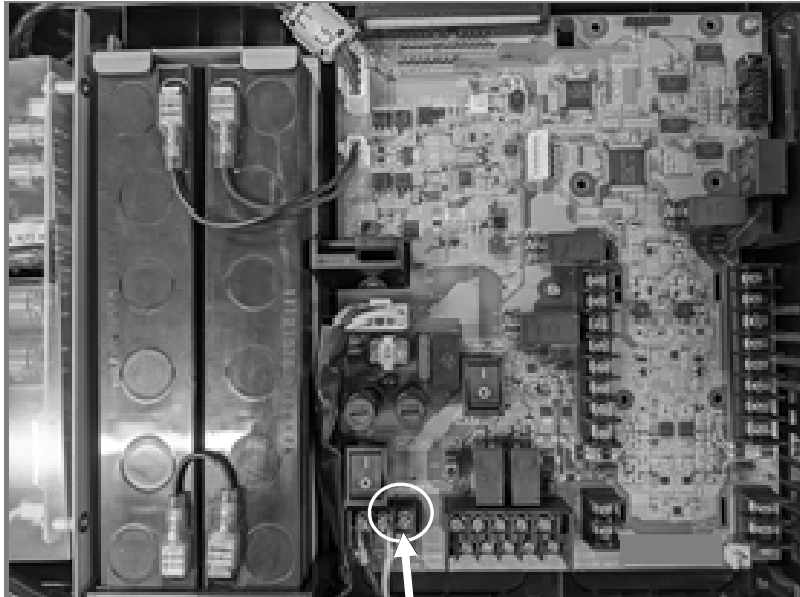
Be sure to ground the product before turning on power for the product.



Terminal 

Be sure to provide grounding. This is required for stable operation and safety of the devices. Never connect the grounding wire to a gas pipe. Use grounding equivalent to Class D grounding (grounding resistance 100 Ω or less).

4-5. Installation procedure

4-5-1. Wall mounting installation procedure

<For 4- to 8-point configuration>

Attach the mounting screws at the four positions in each corner.

* Be careful to avoid accidentally pinching your fingers when mounting the product, as shaking the product excessively may cause the upper door to close.

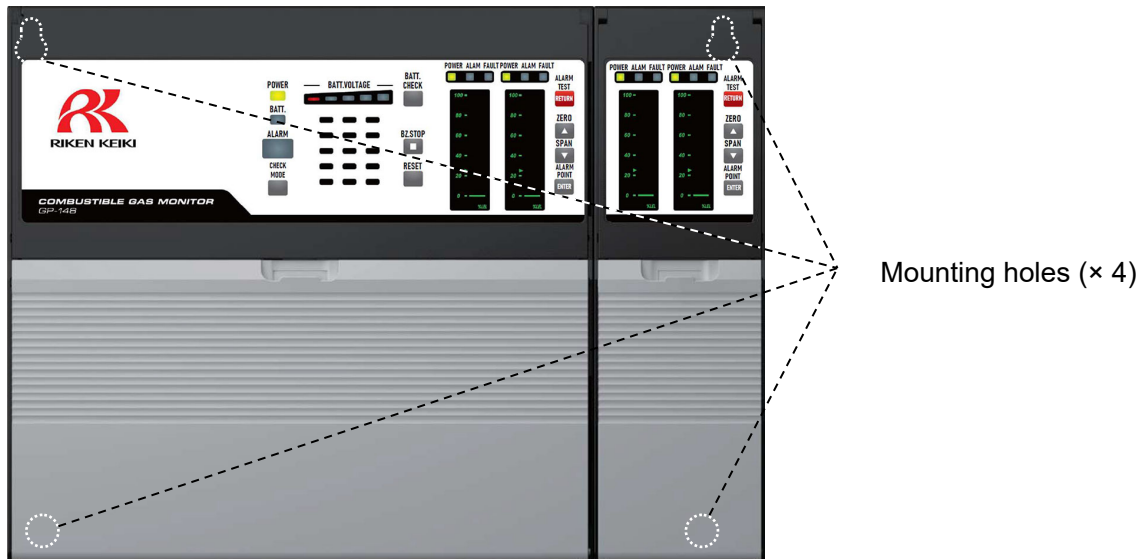

<For 10-/12-point configuration>

Attach the mounting screws at the four positions in each corner and also the two positions on the indicator unit adjoining the base unit.

* Be careful to avoid accidentally pinching your fingers when mounting the product, as shaking the product excessively may cause the upper door to close.

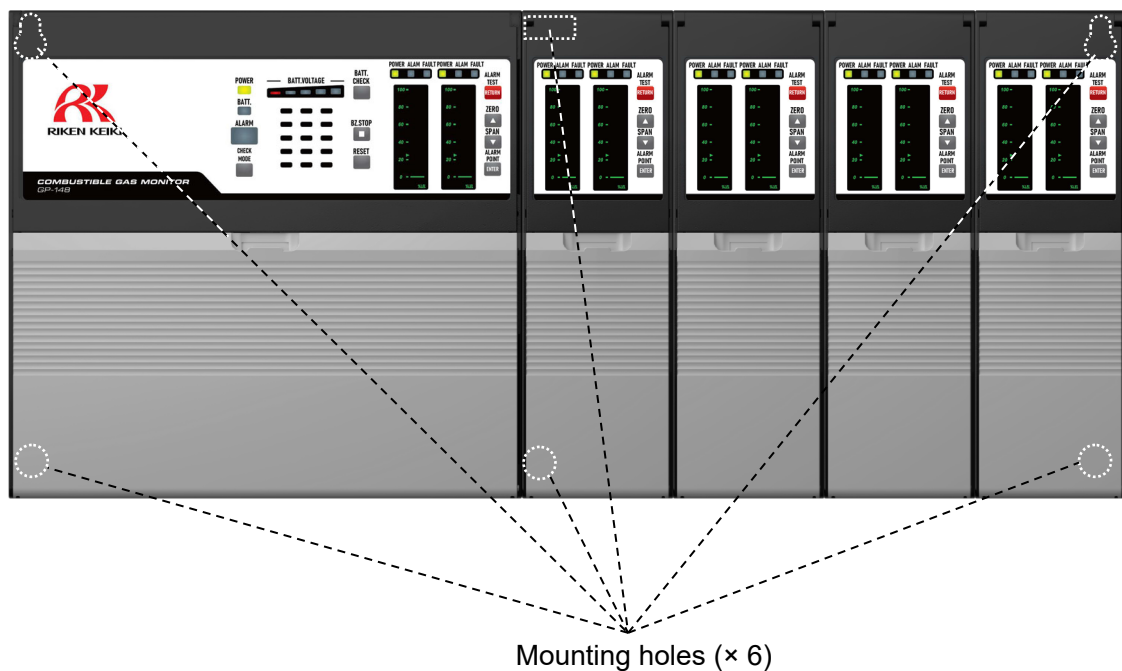

4-5-2. Rack mounting installation procedure

- ① Mount the GP-148 into the mounting hole.

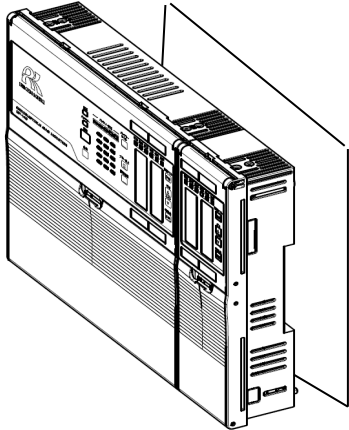

* For more information on the mounting procedure, refer to '3-3. Mounting diagram'.

- ② Open the upper and lower doors. Attach the rack mounting fittings B (with bolt and cap nut) to the rack mounting fittings A already attached at four locations (six locations for 10-/12-point configuration). Loosen the screws on the rack mounting fittings B before attaching.

* Be careful to avoid accidentally pinching your fingers when mounting the product, as shaking the product excessively may cause the upper door to close.

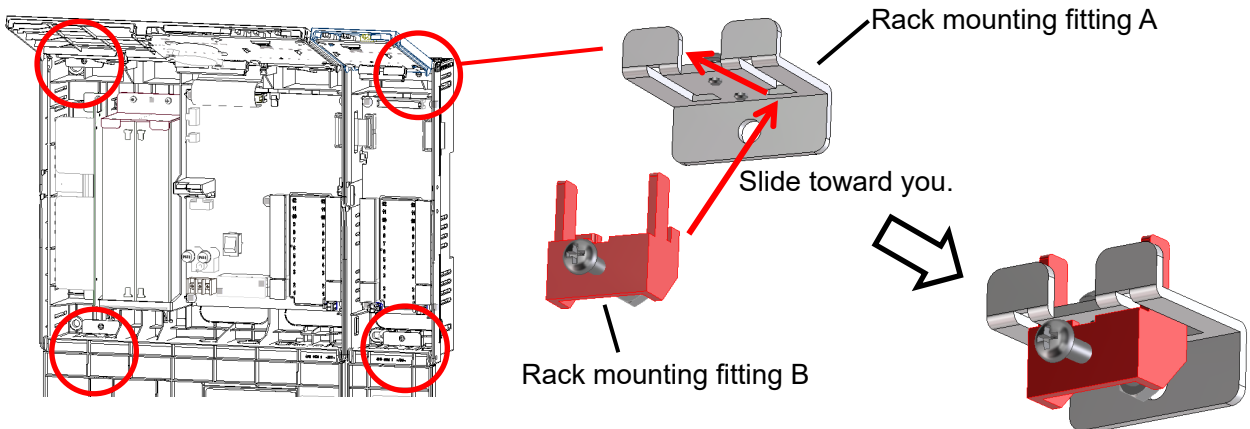

- ③ Attach the rack mounting fittings B to the four (or six) locations described in step ② above, then tighten the bolts to complete the mounting procedure.

* As with the wall mounting procedure, there are four rack mounting fitting locations for the 4- to 8-point configuration, and six for the 10-/12-point configuration.

4-6. Device connection

4-6-1. Power supply connection

The power supply specifications for the product are 100 - 120 V AC or 200 - 240 V AC, 50/60 Hz. Use a power supply with ratings within this specification range.

Connect the grounding terminal to your local grounding terminal before connecting the power supply. Use a Class D grounding resistance (not exceeding 100 Ω). After grounding, allow the product to stabilize before connecting the power supply and other connections.

4-6-2. Connecting to contact outputs

The outputs from the indicator unit are the individual alarm contacts 1 (gas alarm contacts) and individual alarm contacts 2 (gas alarm contacts or fault alarm contacts). The outputs from the base unit are the general alarm contacts and external buzzer contacts.

The contact capacity is 250 V AC, 2 A for the general alarm contacts and 250 V AC, 1 A for the external buzzer contacts. (Both with resistance load) Install an auxiliary relay circuit if connecting to a load that exceeds the contact capacity.

4-6-3. Connecting to the 0 - 6 - 12 V DC output

The standard output from the base unit is a 0 - 6 - 12 V DC signal. The load current does not exceed 10 mA. Use shielded cable equivalent to CVVS for the cable connections.

4-7. Wiring

Base unit

External terminals

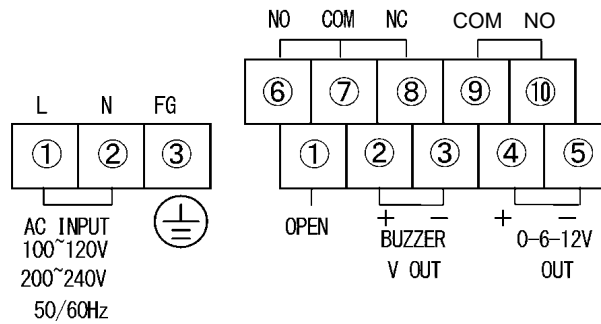

Screw size: M3

Power supply unit

- | | | |
|---|------|---|
| ① | (L) | } Power input 100 - 120 V AC or 200 - 240 V AC (50/60 Hz) |
| ② | (N) | |
| ③ | (FG) | |

General alarm unit

- | | | |
|---|--------|---|
| ① | (OPEN) | Not used |
| ② | (+) | } External buzzer power supply output: 24 V DC (load current 10 mA or less) |
| ③ | (-) | |
| ④ | (+) | } General alarm voltage output: 0 - 6 - 12 V DC (load current 10 mA or less) |
| ⑤ | (-) | |
| ⑥ | (NO) | } General alarm contact output: No-voltage C contact (Contact capacity: 250 V AC, 2 A, resistance load) |
| ⑦ | (COM) | |
| ⑧ | (NC) | |
| ⑨ | (COM) | } External buzzer contact output: (Contact capacity: 250 V AC, 1 A, resistance load) |
| ⑩ | (NO) | |

Indicator unit
External terminals

Gas detector connections

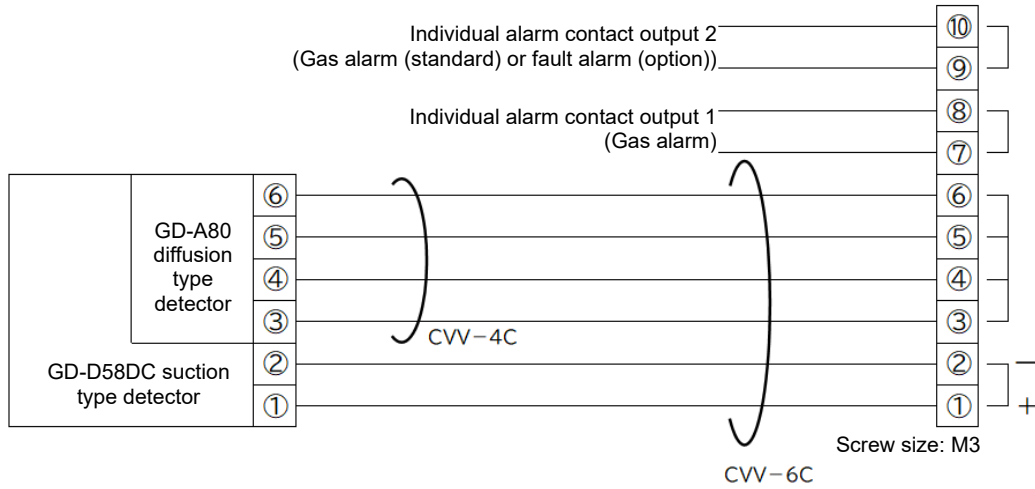

Flame detector connections

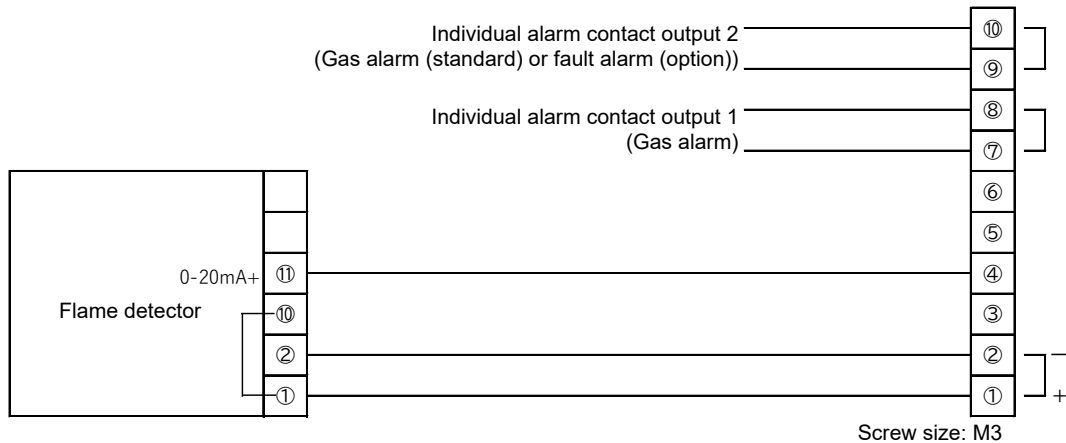

⚠ CAUTION

- Take care to avoid damaging internal electronic circuits during wiring work.
- Use a CVV 1.25 mm² or 2 mm² (4-core) cable to connect the indicator to the detector. RIKEN KEIKI rejects all liability in cases where a cable other than the type specified is used.
- Use separate cables to connect the indicator to the detector, for the input power supply, for the pump power supply, and for the external output. Do not use cables routed within the same core.
- Do not route the power cables, detector cables, and signal cables alongside power lines for motors or similar equipment.
- Do not use the pump power supply output from the detector to operate other devices.
- Only three-wire cables can be used for connecting the indicator to the flame detector. (Four-wire cables cannot be used.)
 Indicator settings are required to connect to a flame detector. These must be specified at the time of ordering.

5. Operation Method

5-1. Preparations for startup

Note the following precautions before connecting the power source. Ignoring these precautions may result in electric shock or damage to the product.

- Ground the product.
- Check to confirm that external wiring is correctly connected.
- Check to confirm that the voltage of the supplied power source is within the rated range.
- The external contacts may activate during adjustment. Take appropriate precautions to safeguard external devices against contact activation.
- Check to confirm that the fuse has the specified rating.

5-2. Basic operating procedures

The product is normally used in detection mode after the power is turned on.



* Buttons other than the CHECK MODE button can be used after selecting the corresponding channel using the selector switch.

WARNING

Switching from detection mode to other modes in an alarm state will cancel the alarm.

5-3. Startup procedure

- (1) Before turning on the power switch, confirm that the product has been installed correctly.
- (2) Open the front cover of the product to reveal the power switch in the lower center.
- (3) Turn on the main power switch.
(Press the top of the switch to turn on; press the bottom of the switch to turn off.)
- (4) Turn on the system power switch.
(Press the top of the switch to turn on; press the bottom of the switch to turn off.)

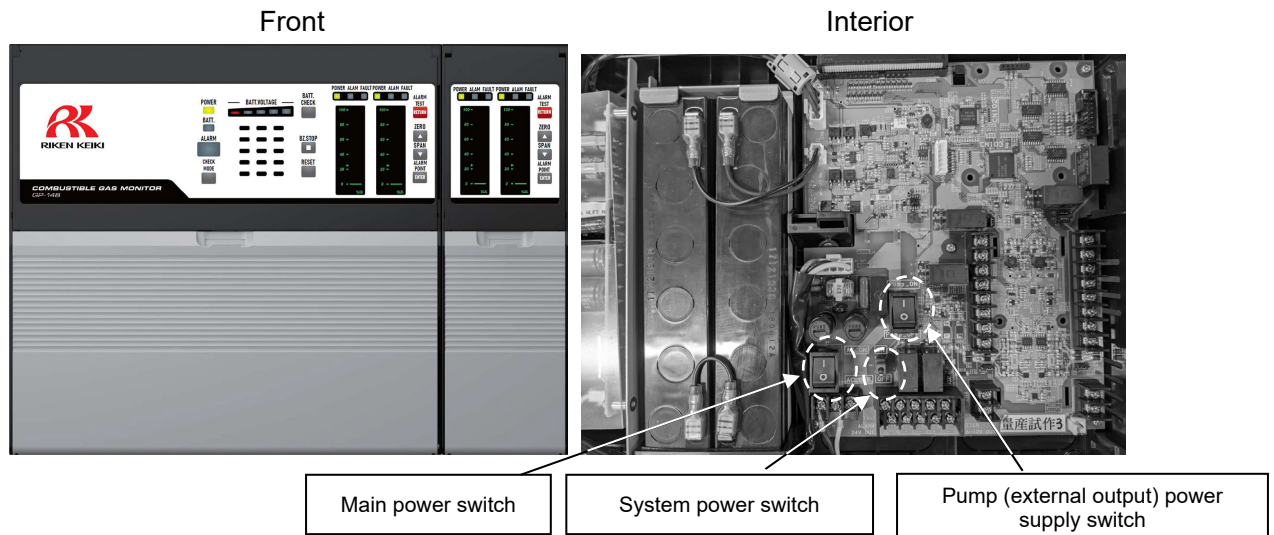

- (5) All lamps will go on when the power is turned on, and the product switches to detection mode once initialization is complete.

<<Startup process>>

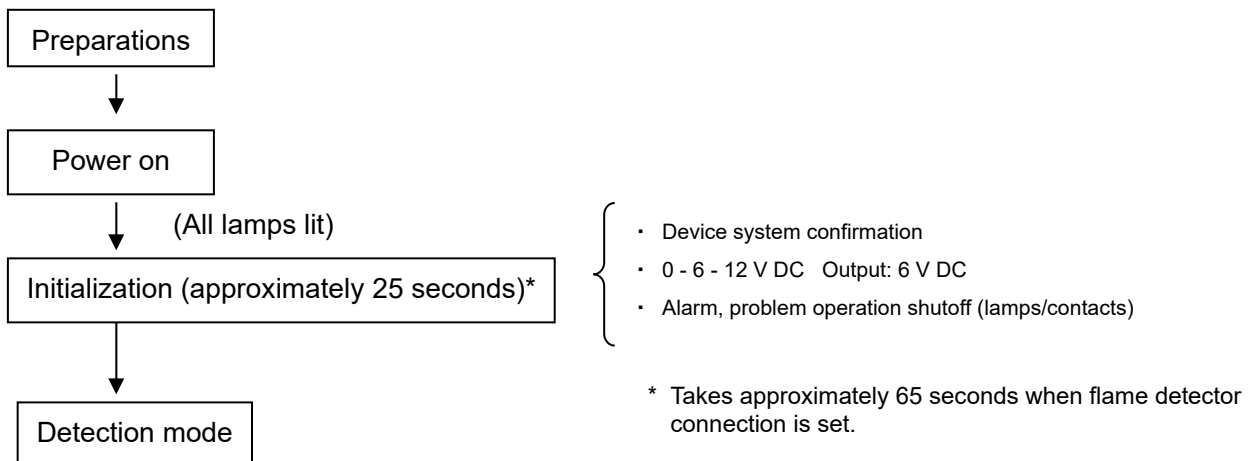

⚠ CAUTION

- Never turn the power off during initialization.
- Even after the system has started up, warmup time is required for sensors if they have been newly installed or replaced. Allow the system to warm up for the specified period of time. Perform calibration once warmup is complete. Also refer to the operating manual for the gas detector.
- Alarm behavior and output signals will be unstable during warmup. Take precautions by notifying the relevant departments that may be affected by abnormalities beforehand.
- If [E-1] is displayed after initialization, turn the power off and then back on again.

5-4. Detection mode

5-4-1. Display operations

Product operations are displayed in the following two ways:

- (1) LCD display: Displays detection target gas concentration and other information.
- (2) LED lamps: Displays the power supply, operation channel selection, gas information, and fault alarm status.

* The LCD display and LED lamps will differ depending on the device status.

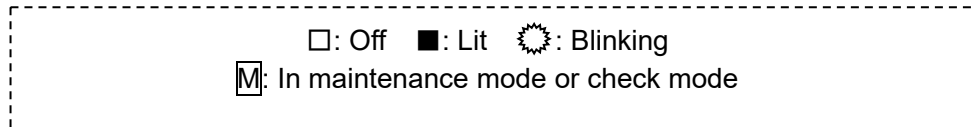

Measurement state

Only the POWER lamp is lit, and the gas concentration display (green bar meter) indicates the sampling gas concentration.

Negative values (below zero) are subject to suppression corresponding to 10 % of the full scale. If the value is below 10 % of the full scale, the bar drops below the zero point, as shown in the figure on the right. ("-0" state)

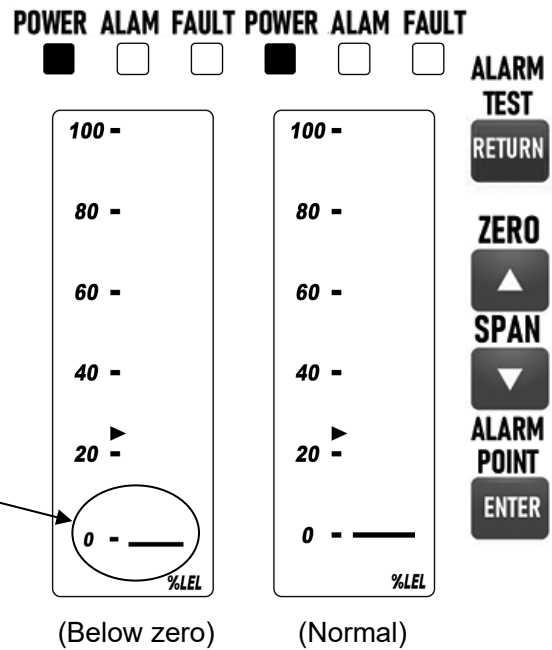

⚠ WARNING
 Accurate gas detection will not be possible in the "-0" state, so zero adjustment must be performed.

Gas alarm

When gas is detected above the alarm setpoint, the gas concentration display (bar meter) turns red, the ALAM lamp (red) blinks on the indicator, and the buzzer sounds. The ALAM lamp (red) also lights up on the base unit.

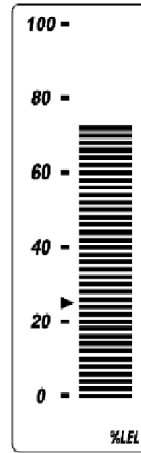
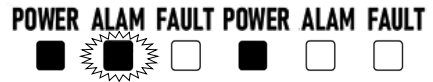

(Gas alarm state)

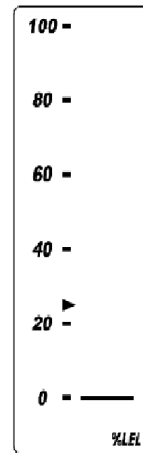

(Normal)

Fault display

A fault alarm occurs if an abnormality is detected in the product (auto-reset).

When a fault alarm occurs, the FAULT lamp lights up (orange), the error code appears on the LCD, and the buzzer sounds.

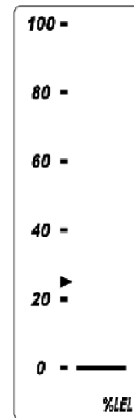
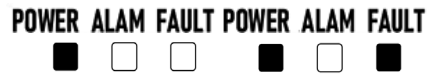

(Normal)

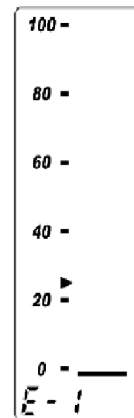

(Fault alarm state)

(LCD display)	(Fault details)
E-9	System error: E.g. Memory error
E-1	Sensor error: E.g. Sensor disconnected
↓	
— — —	Warmup due to error recovery: 25 seconds

If multiple faults occur, the error display alternates between the codes.
 The memory error cannot be reset. Contact RIKEN KEIKI.
 The sensor error is reset by resolving the sensor disconnection problem.

5-4-2. External output (general alarm output voltage) operation

0 - 6 - 12 V DC model

- (1) Signal transmission method: Voltage output (non-insulated)
- (2) Transmission path: CVVS
- (3) Transmission distance: Maximum 10 m
- (4) Connected load resistance: Minimum 1 MΩ
- (5) Status signal level
 - ① Detection mode: 6 V
 - ② Gas alarm: 12 V
 - ③ Initialization: 6 V
 - ④ Check mode: 6 V
 - ⑤ Maintenance mode: 6 V
 - ⑥ Alarm test: 12 V
 - ⑦ Fault alarm: 0 V
- (6) Power supply failure: 0 V

5-4-3. Alarm test

Used to check the product alarm operation by generating a simulated signal equivalent to the gas concentration.

- ① Select the desired channel using the selector switch.
(The POWER lamp lights up orange for the selected channel.)

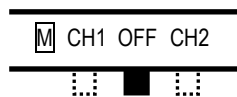

- ② Hold down the ALARM TEST button to simulate an alarm level and trigger the alarm operation.
(The buzzer and general alarm output are not linked.)
- ③ Release the ALARM TEST button to end the alarm test.
- ④ Return the selector switch to the center position to end.

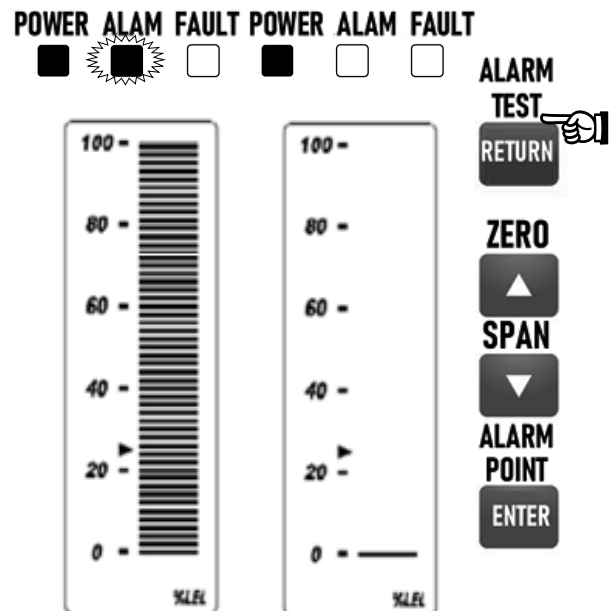

5-4-4. Alarm setpoint confirmation

Used to confirm alarm setpoints (setting values).

- ① Select the desired channel using the selector switch.
(The POWER lamp lights up orange for the selected channel.)

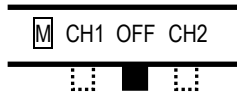

- ② Hold down the ALARM POINT button to display the current alarm setpoint and check the value set.
- ③ Release the ALARM POINT button to return to detection mode.
- ④ Return the selector switch to the center position to end.



POWER ALAM FAULT POWER ALAM FAULT
 ■ □ □ ■ □ □

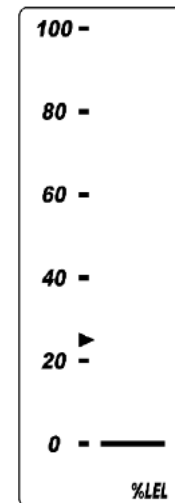
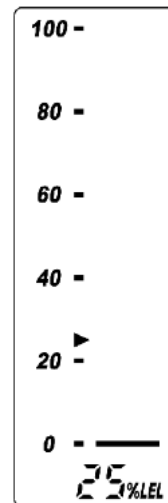

ALARM TEST
RETURN

ZERO
▲

SPAN
▼

ALARM POINT
ENTER



5-5. Check mode

The GP-148 features a check mode to facilitate checks.

Check mode can be used to perform alarm tests, zero adjustment, span adjustment, and alarm setpoint checking.

Check mode cannot be accessed when operating using the UPS.

5-5-1. Check mode procedures

- ① Hold down the CHECK MODE button.

All channels on the indicator switch to check mode.

The **M** symbol appears on the LCD, and the indicator address* is first displayed for five seconds, after which the concentration is displayed.

* The address is internal information, and should be used as is without any worries.

Example address display

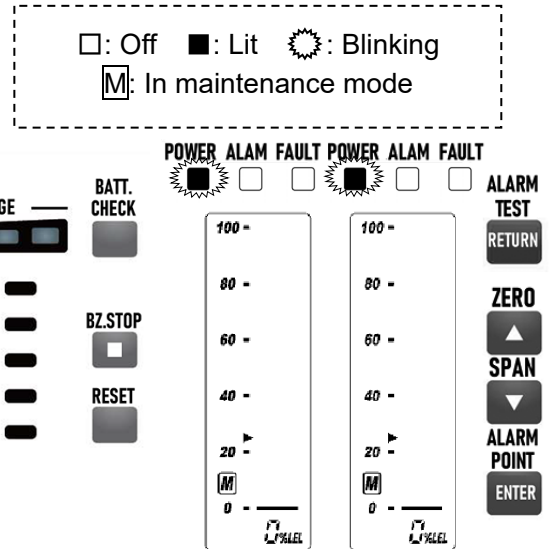
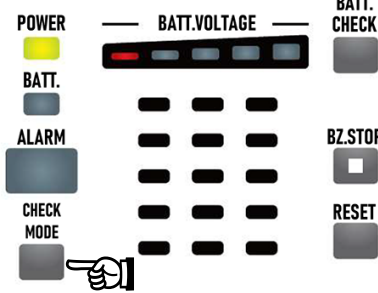

- ② Slide the selector switch to the desired channel.

The POWER lamp changes to orange for the selected indicator.

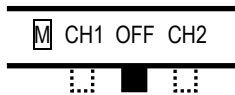

- ③ The corresponding operations for each of the buttons are as follows:

Alarm test

Hold down the ALARM TEST button to simulate an alarm level and trigger the alarm operation. The buzzer and general alarm output will also operate.

⚠ WARNING

Before performing an alarm test (transmission test), notify the relevant departments beforehand and take precautions to prevent problems due to the external output signals and alarm contacts.

Zero adjustment

When the ZERO button is pressed, [ZEro] appears for two seconds before the concentration is displayed.

Press the ENTER button with the detector in fresh air. [CAL] appears, and then zero adjustment starts automatically.

[PASS] appears if adjustment is successful, and [FAIL] appears if adjustment fails. The system automatically returns to the check mode initial screen.

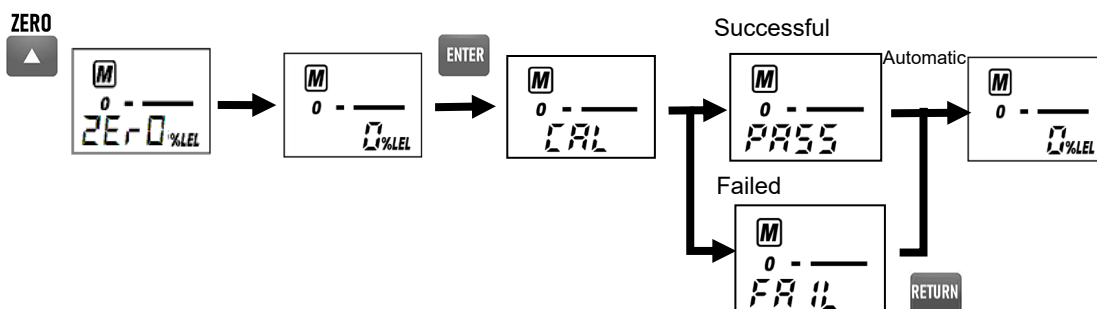

Span adjustment

When the SPAN button is pressed, [SPAN] is displayed for two seconds before the concentration is displayed.

When a reading appears, feed the calibration gas into the detector.

Once the reading stabilizes, press the ENTER button. * Setting is not possible if the reading is less than 10 % of the full scale.

Use the ▲ and ▼ buttons to adjust to the concentration of the calibration gas, then press the ENTER button.

[CAL] appears, and adjustment is performed.

[PASS] appears if adjustment is successful, and [FAIL] appears if adjustment fails. The system automatically returns to the check mode initial screen.

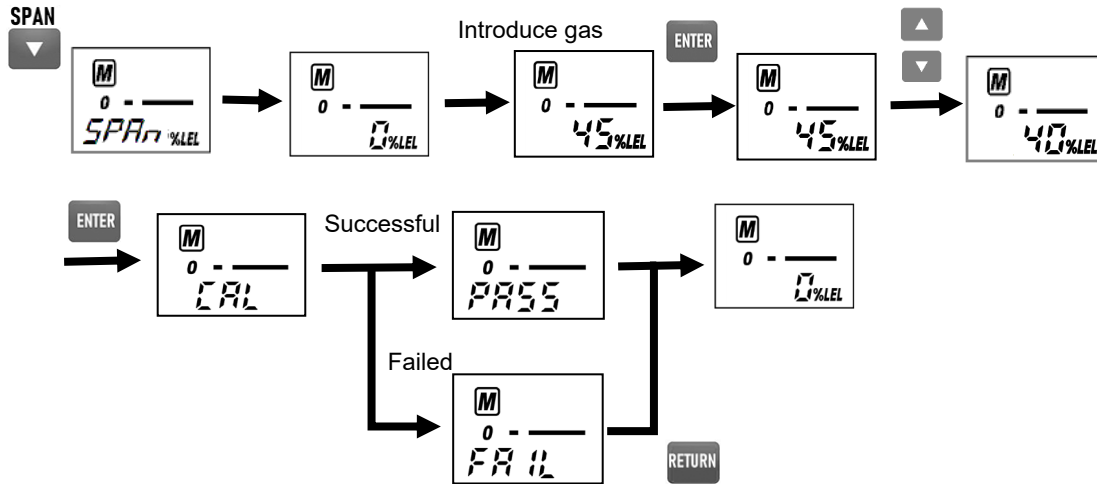

Alarm setpoint confirmation

Hold down the ALARM POINT button to display the alarm setpoint for checking.

Releasing the button returns to the check mode initial screen.

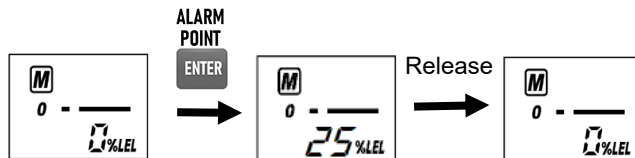

- ④ Return the selector switch to the center position once checking is complete.
Hold down the CHECK MODE button to return all channels to detection mode.

⚠ WARNING

Be sure to return to detection mode after checking is complete.
The product will automatically return to detection mode after 10 hours if left in check mode.

5-6. UPS operation (* for UPS-equipped models)

5-6-1. Functions

(1) External power supply monitoring function

This monitors the output voltage of the switching power supply, and if it detects a voltage drop, determines that the main power supply has been lost (power failure) and automatically switches to operation using the UPS.







(2) UPS monitoring function (over-discharge protection function)

This monitors the battery voltage when operating using the UPS, and automatically shuts down the UPS supply if it detects a low battery voltage.

5-6-2. Display and operations

(1) Power supply status display function

The POWER and BATT. lamps light up or blink depending on the power supply status.

	External power supply operation	UPS operation*	Discharge test
	POWER  BATT. 	POWER  BATT. 	POWER  BATT. 
POWER lamp	Lit	Lit	Lit
BATT. lamp	Off	Lit	Blinking

* The BATT. lamp starts blinking (two seconds on/two seconds off) to save energy 30 minutes after starting UPS operation.

(2) Battery voltage display function

UPS (battery) voltage is displayed by bar meter.

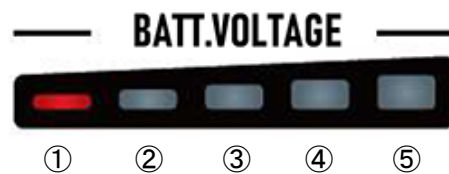

26 V or more:	①②③④⑤	Lit	Color: Green
25 V or more:	①②③④	Lit	Color: Green
24 V or more:	①②③	Lit	Color: Green
23 V or more:	①②	Lit	Color: Orange
21 V or more:	①	Lit	Color: Red
Less than 21 V:	①	Blinking	Color: Red

* All display sections are lit up green when the voltage is 24 V or more. Nothing is displayed if no UPS is included.

(3) Discharge test

Used to check the battery capacity.

① Start discharge test

Hold down the BATT. CHECK button for at least three seconds.

The POWER lamp lights up and the BATT. lamp blinks.

The system switches to UPS operation and discharging starts.

② End discharge test

Hold down the BATT. CHECK button for at least three seconds.

The system returns to normal operation using the main power supply.

WARNING

Be sure to press the BATT. CHECK button to return to normal operation after the discharge test has ended.

5-6-3. UPS operation settings

The indicator operation can be set to one of the following on switching to UPS when a power failure occurs.

① Continuous measurement

② Off

③ 30 minutes continuous measurement before turning off

④ 30 minutes continuous measurement followed by intermittent measurement

— Measurement on time: Determined for each sensor Settings cannot be changed.

(HW-6239: 30 s, other sensors: 15 s)

— Measurement off time: Select from 10/30/60/90 mins.

This setting can be configured for each channel, and is performed in maintenance mode [2-4.0].

For more information on settings, refer to the maintenance mode explanation.

5-7. Shutdown procedure

To shut down the product, open the front lower cover on the base unit, turn off the system power switch, then turn off the main power switch. After this, shut off the power supply (100 - 240 V AC) to the product.

WARNING

- Shutting down product operation may activate an alarm in an upstream (central) system. Before shutting down product operation, apply an inhibit (point skip) at the upstream (central) system. Additionally, check the devices connected to the external output of the product and the external contact output terminals to determine whether it is acceptable to turn off the power to those devices.
- If a UPS is connected, the UPS will continue to operate if the system power is on, even if the main power switch is turned off.

6. Operations and Functions

6-1. Gas alarm pattern

Gas alarm: Triggered if the concentration of the detected gas reaches or exceeds the alarm setpoint
《Self-latching operation》

*NOTE

The alarm setpoints (standard) are preset at the factory.
The product features an alarm delay time (default: two seconds) set to prevent false alarm activation, but this can be canceled if it is not needed.

(1) Display operations

① Gas concentration display

If the reading exceeds the detection range (full scale exceeded), the bar meter indication blinks.

② POWER lamp (green)

Remains continuously lit.

③ ALARM lamp (red)

The ALARM lamp lights up when the alarm setpoint is reached or exceeded.

The ALARM lamp goes out when the gas concentration falls below the alarm setpoint after pressing the BZ. STOP button followed by the RESET button.

(2) External output operations

① 0 - 6 - 12 V DC output

12 V DC is output when an alarm occurs. The maximum load that can be connected is 10 mA.

② Alarm contacts

The contacts operate if the gas concentration reaches or exceeds the alarm setpoint.

The contact operation resets automatically when the gas concentration falls below the alarm setpoint after pressing the BZ. STOP button followed by the RESET button.

Alarm pattern

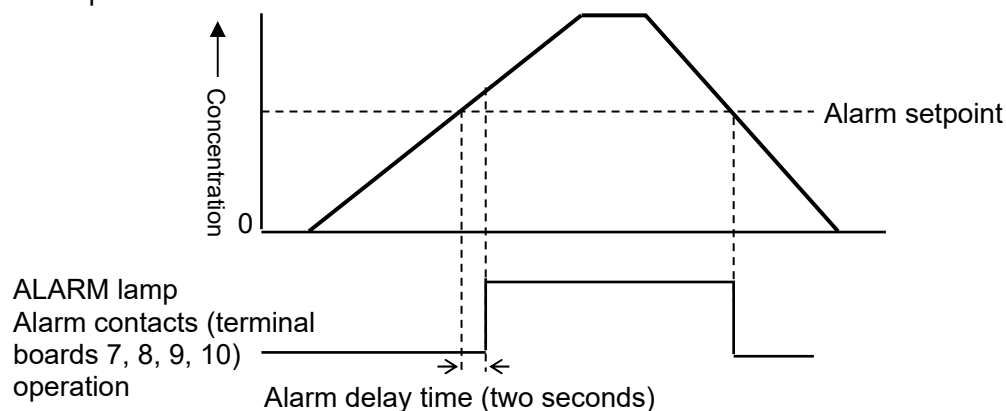

(3) Action when a gas alarm occurs

Reaction to leakage gas

If a gas alarm occurs, take action promptly in accordance with your management rules. The typical procedures are as follows:

- ① Check the product reading.

***NOTE**
In the case of momentary gas leaks, the reading may have already dropped by the time the reading is checked. The reading may also drop while in the temporary alarm state due to factors other than gas alarms, such as noise or incidental conditions.

- ② Keep persons out of the monitored zone to ensure safety in accordance with your gas alarm control concentrations.
- ③ If the gas concentration display remains unchanged, close the main valve for the gas in question and check to confirm that the concentration reading drops.
- ④ Access the gas leakage location, equipped with protective gear to avoid any possible hazards due to residual gas, and check for the presence of residual gas using a portable gas detector.
- ⑤ Once you have determined that no danger exists, take action to fix the gas leak.

6-2. Fault alarm pattern

Fault alarm: Occurs if an abnormality is detected in the product.

Errors other than a system abnormality [E-9] is auto-reset.

When a fault alarm occurs, the FAULT lamp lights up (orange), the error code appears on the LCD, and the buzzer sounds. Press the BZ. STOP button to stop the buzzer.

After the product has successfully recovered from the fault, it restarts with the process normally performed right after it is turned on (initialization). If multiple alarms occur, the error display alternates between the codes.

If the problem lies with the product and the fault occurs repeatedly, contact RIKEN KEIKI immediately.

POWER ALAM FAULT POWER ALAM FAULT

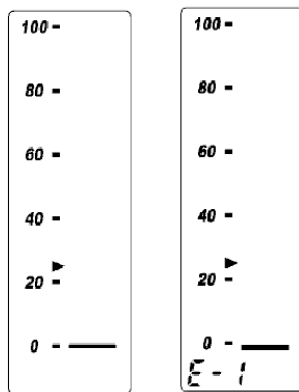

* Example display: E-1 sensor error

***NOTE**
For more information on faults (error messages), refer to '9. Troubleshooting'.

6-3. Gas alarms caused other than by gas detection

Reaction to interfering gas

Contact RIKEN KEIKI regarding interference gases.

Sensor drift over time

Check the readings in the daily maintenance, and recalibrate the detector as necessary.

Noise from peripheral equipment

Review the installation location and wiring, and add noise prevention devices to the product and detector as necessary.

The actual measures required will differ depending on the individual site conditions.

The effects of momentary noise may be experienced, such as due to lightning. Preventive measures such as surge protection can be implemented once the causes have been identified.

6-4. Functions

<Suppression function>

Detectors connected to the product may be affected by environmental fluctuations (such as temperature and humidity characteristics) and interference gases (interference characteristics), which may affect the readings. Readings may therefore sometimes fluctuate around the zero level even under normal conditions with no gas leaks.

This function is designed to minimize the effects of these ambient fluctuations and interference gases around the zero level to prevent problems from a management perspective. Using this function suppresses reading fluctuations below the preset value* to give a zero reading.

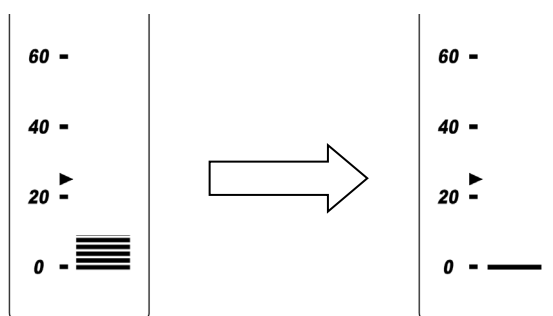

Without suppression function

The reading fluctuates around the zero level.

With suppression function

Displays zero up to the preset value.

⚠ CAUTION

Negative values (below zero) are subject to suppression corresponding to 10 % of the full scale. If the negative value exceeds 10 % of the full scale, the bar drops down (-0 state), but since accurate gas detection will not be possible in this state, zero adjustment must be performed.

<Zero follower function>

Detectors connected to the product may suffer sensitivity variations when used continuously for extended periods.

This function is programmed processing designed to stabilize the zero point by correcting fluctuations in readings around the zero point (zero drift) caused by sensitivity variation over time. Default settings: OFF (FS = 100 %LEL), ON (when FS is other than 100 %LEL)

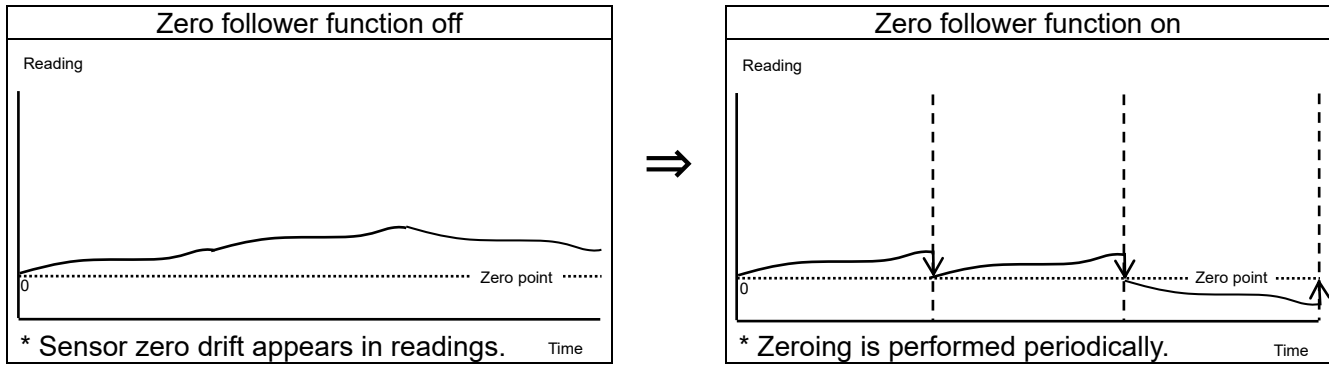

<Peak hold function>

This holds the peak concentration bar display after an alarm occurs in normal measurement (detection mode). The FS bar blinks if the full scale is exceeded. Press the BZ. STOP button then the RESET button to reset the hold function.

6-5. Operations when setting flame detector (option) connection

The product is able to receive the 0 - 20 mA signal output from a flame detector (40/40 series) and display the fault, normal, warning, or alarm states, accordingly. To start up, turn on the system power switch, then turn on the pump (external supply) power switch.

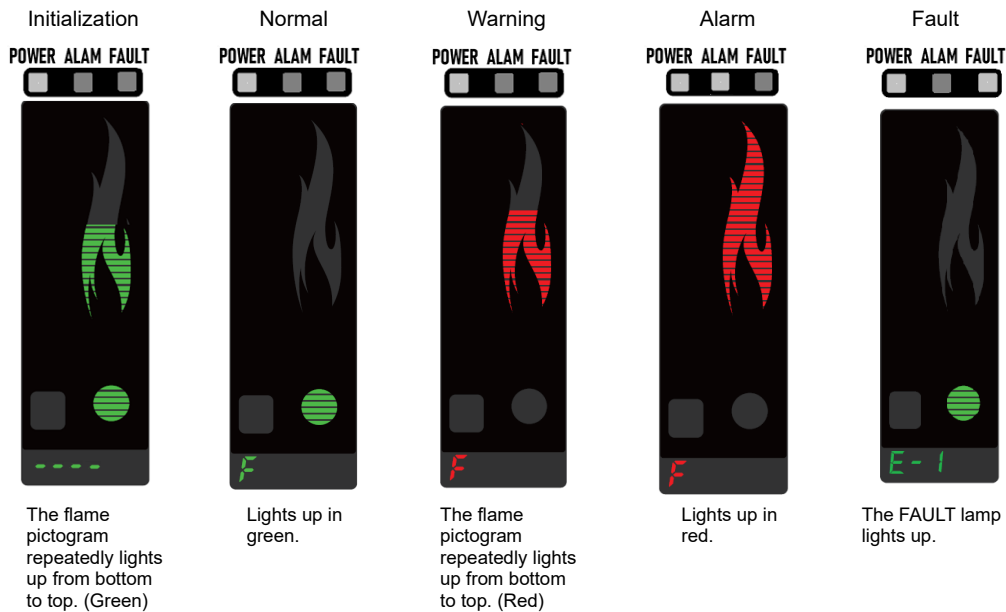

The flame detector (40/40 series) setting must be set to [0-20mA Wiring Option 1 (source 3-wire)]. For more information on settings and details, such as alarm delay time, refer to the flame detector (40/40 series) operating manual.

7. Maintenance

The product is an important safety and disaster-prevention device. Maintain the product at regular intervals to ensure performance and improve disaster-prevention and safety reliability.

7-1. Maintenance intervals and items

- Daily maintenance: Perform maintenance before commencing work.
- Monthly maintenance: Inspect the alarm circuit (alarm test) once a month.
- Regular maintenance: Perform maintenance at least once every six months to ensure performance as a safety device.

Inspection item	Inspection details	Daily maintenance	Monthly maintenance	Regular maintenance
Power supply check	Check to confirm that the power lamp lights up.	○	○	○
Concentration display check	Check to confirm that the concentration reading is zero. If the reading is offset, confirm that there is no interference gas in the vicinity of the detector, then perform zero adjustment.	○	○	○
Alarm test	Use the alarm test function to check the alarm circuit.	—	○	○
Span adjustment	Perform span adjustment using a calibration gas.	—	—	○

<Maintenance service>

- RIKEN KEIKI provides services related to regular maintenance, including span adjustment, as well as other adjustments and maintenance.

Preparing calibration gas requires the use of dedicated tools, such as gas cylinders of the specified concentration and gas sampling bags.

Our certified service engineers have knowledge of the dedicated tools used for these services, along with expertise in products. We recommend taking advantage of our maintenance service to ensure safe use of the product.

- The main items of the maintenance service are as follows. Contact RIKEN KEIKI for more information.

Major service details

- Power supply check: Check the power supply voltage. Check to confirm that the power lamp lights up. (Check to see if it is possible to determine that this is the relevant location in the system.) (Check the operation of the UPS (uninterruptible power system), if used.)
- Concentration display check: Check to confirm that the concentration reading is zero using zero gas. Perform zero adjustment if the reading is not zero.
- Alarm test: Check the alarm circuit using the alarm test function.
- Check alarm lamps (Check alarm operation)
 - Check external alarms (Check buzzer and other external alarm operations)
- Span adjustment: Perform span adjustment using a calibration gas.
- Gas alarm check: Check the gas alarm using a calibration gas.
- Check alarms (Confirm alarm activation when alarm setpoint is reached)
 - Check delay time (Check delay time until alarm activation)
 - Check alarm lamps (Check alarm operation)
 - Check external alarms (Check buzzer and other external alarm operations)
- Product cleaning/repair: (Visual inspection) Check the product exterior, covers, and interior for dirt and damage, and clean and repair problem areas. Replace parts if cracked or damaged.
- Product operation check: Operate the keys to check the behavior of various functions and the parameters.
- Consumable parts replacement: Replace sensors and other consumable parts

7-2. User mode

User mode is used to check the product status.

Select the desired channel using the selector switch, then hold down the ▲ and ▼ buttons simultaneously.

The system switches to user mode, and [1-0] is displayed. The **M** icon blinks. The POWER lamp blinks orange on the selected indicator.

1-0 1.0.0 to 1.0.2 allow the internal software version to be checked. (Three types)

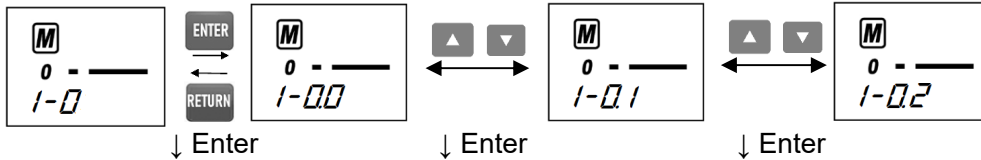

1-1 Used to check the indicator unit internal address displayed. (Not normally used)

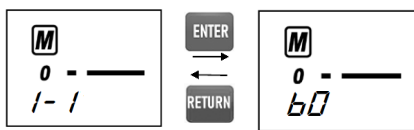

1-2 Displays settings.

1-2.0 The settings displayed automatically scroll.

The display scrolls in the order gas number, alarm setpoint, alarm delay, zero suppression value, zero follower on/off/time.

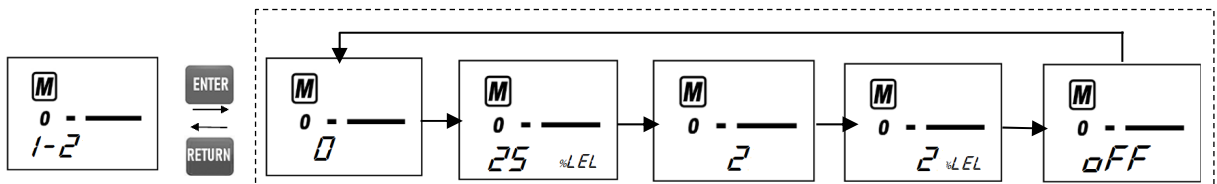

Example display: Gas number: 0, alarm setpoint: 25 %LEL, alarm delay: 2 s, zero suppression value: 2 %LEL, zero follower: off

1-2.1 Gas number, **1-2.2** Alarm setpoint, **1-2.3** Alarm delay time, **1-2.4** Zero suppression value, **1-2.5** Zero follower on/off time

1-3 Menu for accessing maintenance mode.
For details, refer to the maintenance mode section.

7-3. Maintenance mode

Maintenance mode is used for detailed setting configuration, such as altering sensors, automatic sensor current adjustment, and altering contact operations.

WARNING

Be sure to return to detection mode after checking is complete.
The product will automatically return to detection mode after 10 hours if left in maintenance mode.

Mode	Item	LCD display	Details
Maintenance mode (Regular maintenance)	Test mode	2-0	2-0.0 Not used 2-0.1 Alarm test 2-0.2 Fault test 2-0.3 LED and LCD test 2-0.4 Memory test
	Zero adjustment	2-1	Performs zero adjustment.
	Span adjustment	2-2	Performs span adjustment.
	Zero/span initialization	2-3	Initializes zero and span values.
	Environmental settings 1	2-4	Individual function settings 2-4.0 Sensor operation settings when using UPS 2-4.1 Not used 2-4.2★ Alarm settings 2-4.3★ Alarm delay time settings 2-4.4★ Alarm pattern settings 2-4.5★ Zero suppression type settings 2-4.6★ Zero suppression value settings 2-4.7 Contact settings 2-4.8 Alarm contact energized/de-energized settings 2-4.9 Not used 2-4.A Not used 2-4.B Not used 2-4.C Not used 2-4.D Alarm test contact output settings 2-4.E Password settings 2-4.F Sensor fault operation settings
	Environmental settings 2	2-5	Individual function settings 2-5.0★ Heater current adjustment 2-5.1 Not used 2-5.2 Detector type/gas number selection 2-5.3★ Alarm value limiter settings 2-5.4 Fault delay time settings 2-5.5 Fault alarm buzzer settings 2-5.6 Zero follower settings 2-5.7 Green LCD brightness adjustment 2-5.8 Red LCD brightness adjustment 2-5.9★ Sensor stop time setting for intermittent measurement 2-5.A Not used
	Display items	2-6	2-6.0 Heater current display 2-6.1 Fault details display 2-6.2 0 - 20 mA input display
	Zero adjustment for intermittent drive	2-7★	Performs zero adjustment for intermittent drive.
	Factory mode	2-8	Not used by the user.
	Return to user mode	2-9	Returns to user mode [1-0].

Selecting flame detector in [2-5.2] disables the setting menu for the gas detector (items marked ★ in list above), preventing use.

Select the desired channel using the selector switch, then hold down the ▲ and ▼ buttons simultaneously. The system switches to user mode, and [1-0] is displayed.

User mode

Use the ▲ and ▼ buttons, then press the ENTER button for [1-3].



Hold down the ENTER button again for at least three seconds.



The system switches to maintenance mode, and [2-0] is displayed.

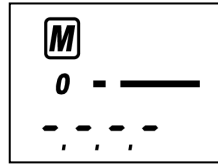
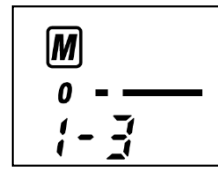

Maintenance mode

2-0

Performs various tests.

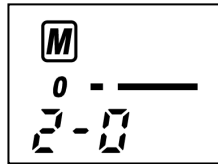

Refer to test mode.

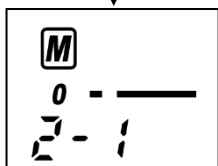

Refer to zero adjustment.

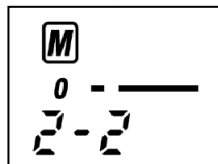

Refer to span adjustment.

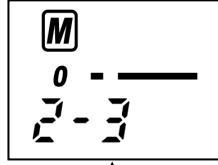

2-3

Initializes the zero and span values. Perform before gas adjustment (zero/span adjustment) after replacing a sensor.

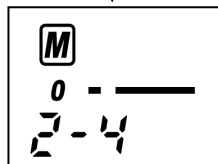

Refer to environmental settings 1.



2-4

Environmental settings 1: Set the various settings.

2-5
Environmental settings 2: Set the various settings.

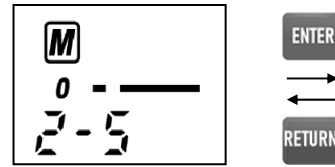

Refer to environmental settings 2.

2-6
Check the display items (current heater, fault details).

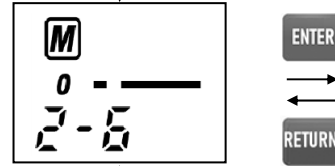

Refer to display items.

2-7
Performs zero adjustment for intermittent drive.

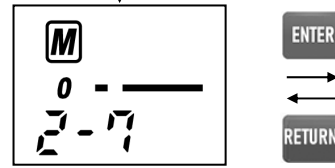

Refer to zero adjustment.

2-8
Switches to factory mode.
Not used by the user

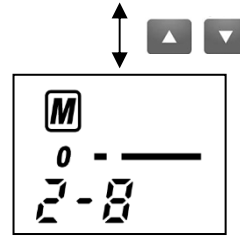

* The time required for execution differs from that for regular zero adjustment. This zero adjustment requires additional time after the 10-second break corresponding to the sensor activation time for intermittent drive.

2-9
Returns to user mode [1-0].

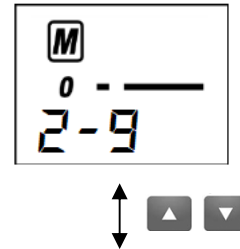

To [2-0]

<2-0 Test mode>

2-0
Press the ENTER button.

2-0.0
Not used

2-0.1
Performs alarm test.

2-0.2
Performs fault test.

2-0.3
Performs LED and LCD test.

2-0.4
Performs memory test.

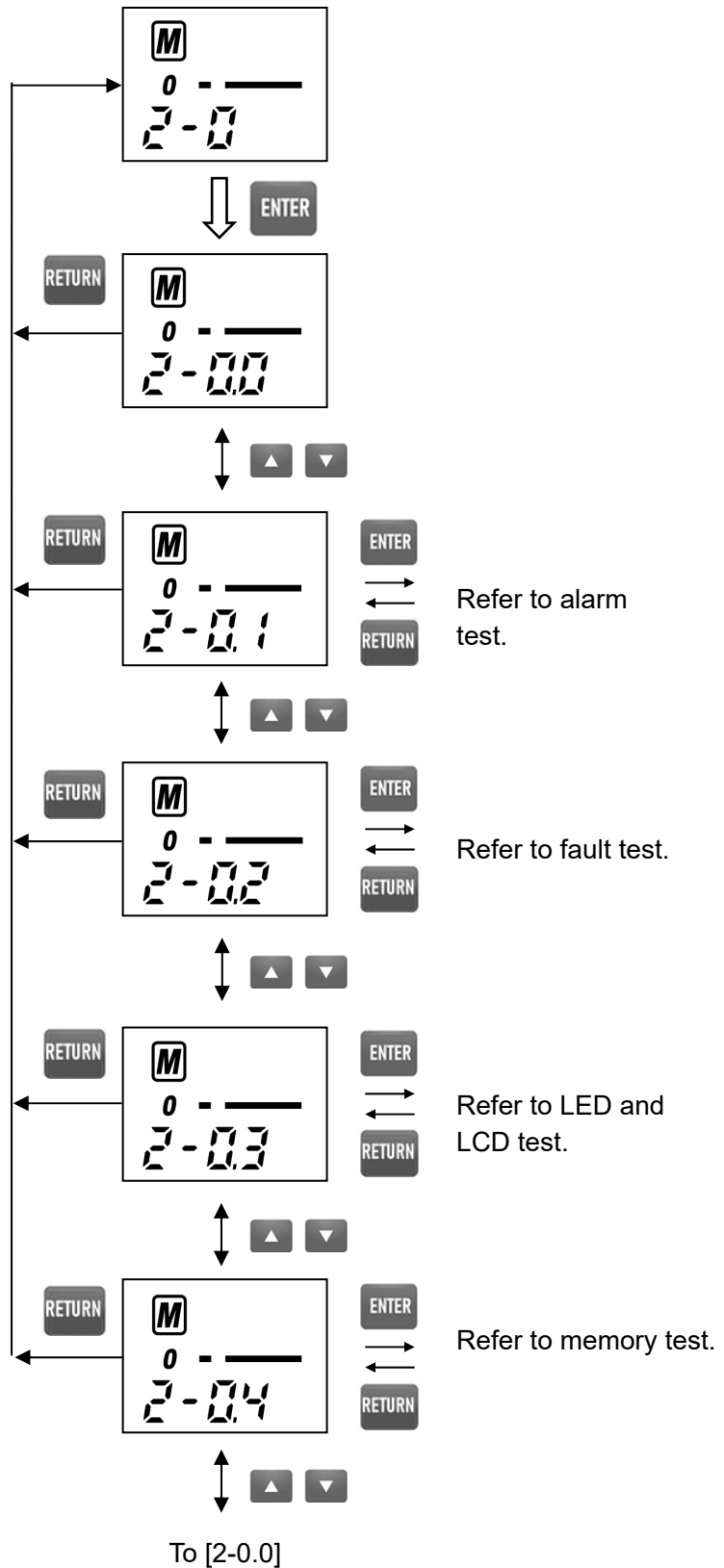

<2-0.1 Alarm test>

- ① Select [2-0.1].
- ② Press the ENTER button.
- ③ Use the ▲ and ▼ buttons to raise or lower the reading bars. The alarm pattern is performed when the alarm setpoint is exceeded.
- ④ Press the RETURN button to return to [2-0.1].

Pressing the RETURN button during the alarm test resets the setting and returns to [2-0.1].

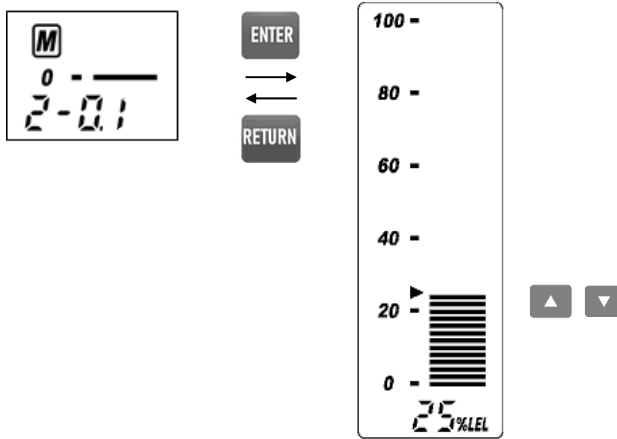

⚠ WARNING
Take care when operating, as the contacts will be active during alarm testing.

<2-0.2 Fault test>

- ① Select [2-0.2].
- ② Press the ENTER button.
- ③ Use the ▲ and ▼ buttons to toggle on or off.
- ④ Press the ENTER button to set.
- ⑤ Press the RETURN button to return to [2-0.2].

Pressing the RETURN button during the fault test resets the setting and returns to [2-0.2].

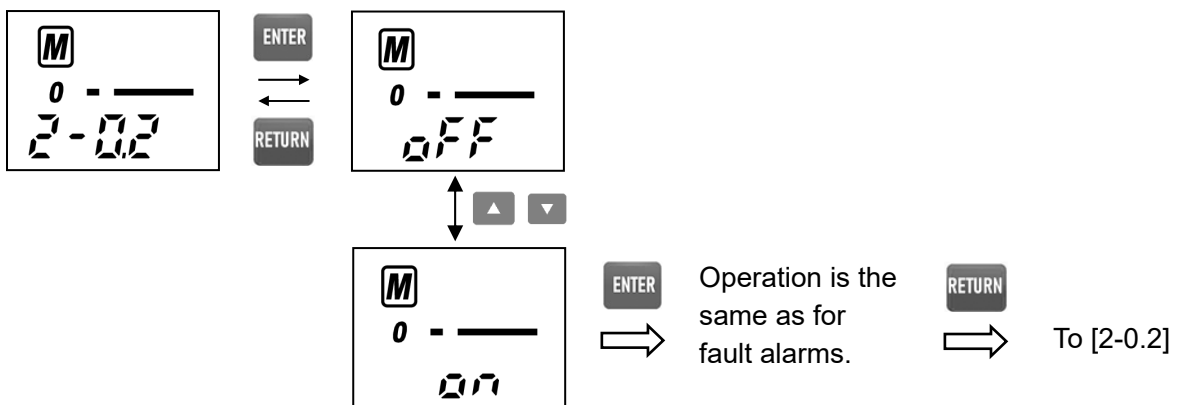

⚠ WARNING
Take care when operating, as the contacts will be active during fault testing.

<2-0.3 LED and LCD test>

- ① Select [2-0.3] on the menu screen.
- ② Press the ENTER button.
- ③ Use the ▲ and ▼ buttons to toggle on or off.
- ④ Press the ENTER button to set.
- ⑤ Press the RETURN button to return to [2-0.3].

Pressing the RETURN button during the test resets the setting and returns to [2-0.3].

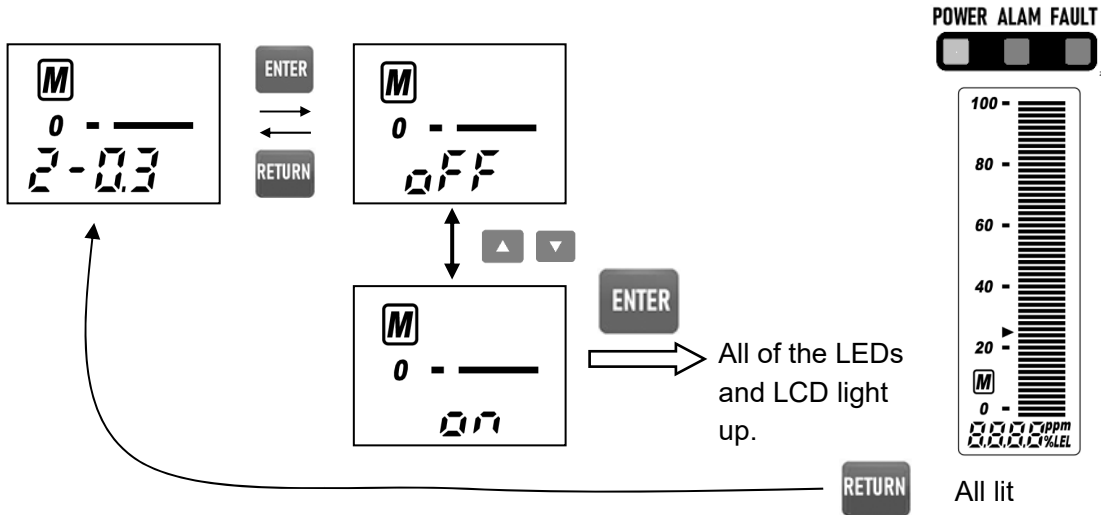

<2-0.4 Memory test>

- ① Select [2-0.4] on the menu screen.
- ② Press the ENTER button.
- ③ [StA] is displayed. Press the ENTER button.
- ④ [CAL] is displayed, and the memory test automatically starts.
- ⑤ [PASS] is displayed if the test is successful. Press the RETURN button to return to [2-0.4].
* If the test fails, press the RETURN button to return.

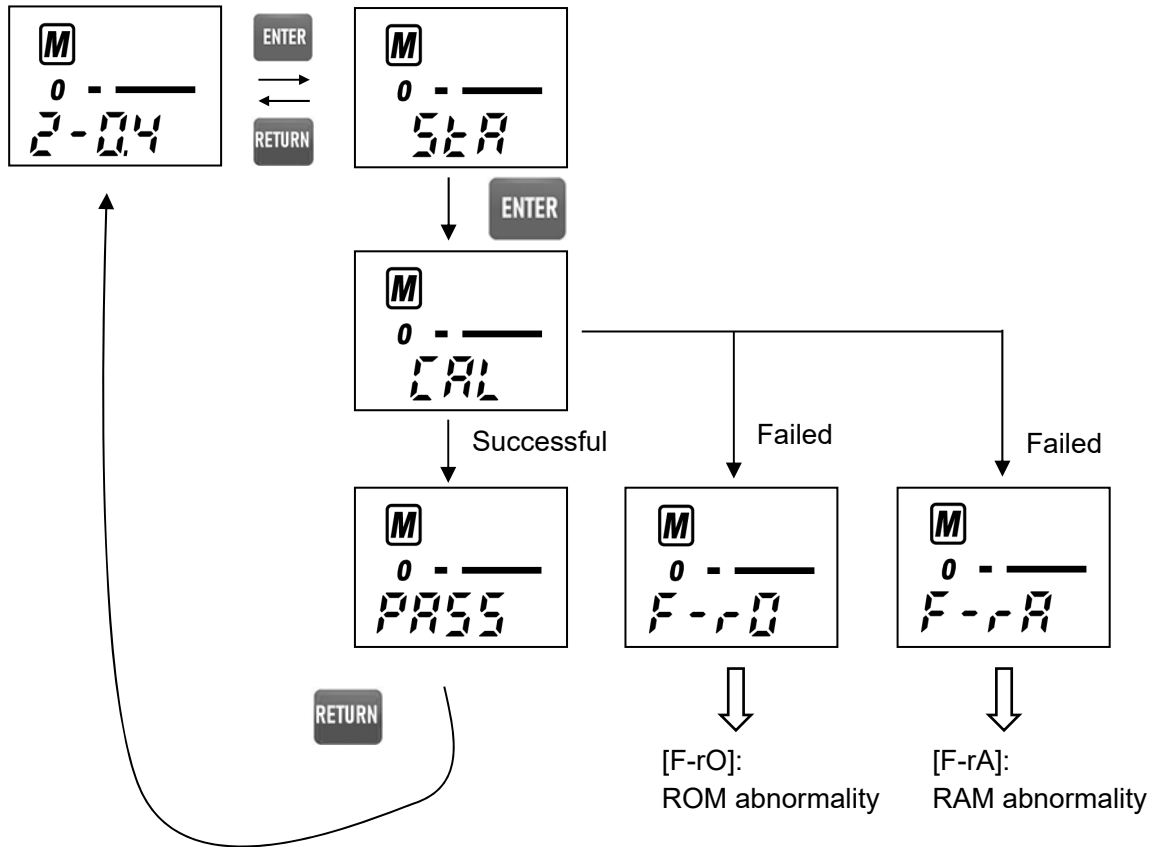

<2-1 Zero adjustment>

Used for zero adjustment of the detector (sensor).

⚠ WARNING

Perform zero adjustment using the zero adjustment gas or in fresh air. Correct adjustment will not be achieved in the presence of interference gases, and this will result in safety hazards in the event of an actual gas leak.

- ① Select [2-1] on the menu screen.
- ② Press the ENTER button.
- ③ [CAL] is displayed, and zero adjustment automatically starts.
- ④ [PASS] is displayed if adjustment is successful, and the display automatically returns to [2-1].
* [FAIL] is displayed if adjustment was unsuccessful.

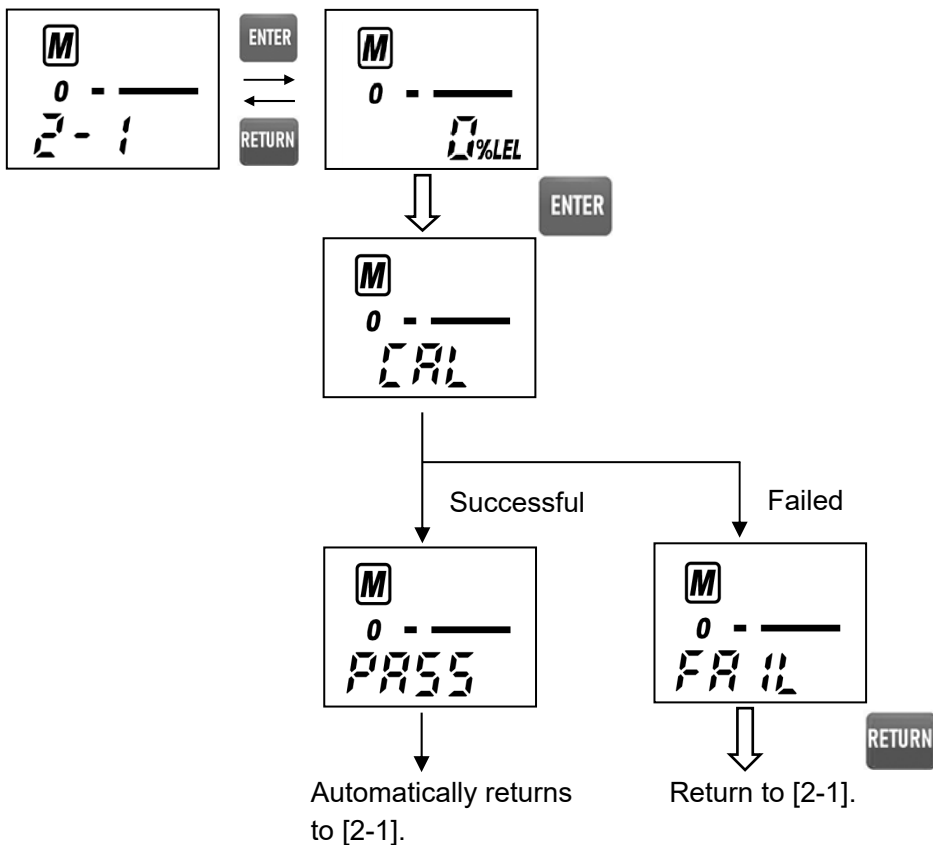

<2-2> Span adjustment

Used for span adjustment of the detector (sensor).

- ① Select [2-2] on the menu screen.
- ② Press the ENTER button.
- ③ Feed the calibration gas.
- ④ Once the reading stabilizes, press the ENTER button.
* Setting is not possible if the reading is less than 10 % of the full scale.
- ⑤ The reading blinks. Use the ▲ and ▼ buttons to adjust the gas concentration.
- ⑥ Press the ENTER button.
- ⑦ [CAL] is displayed, and gas adjustment automatically starts.
- ⑧ [PASS] is displayed if adjustment is successful, and the display automatically returns to [2-2].

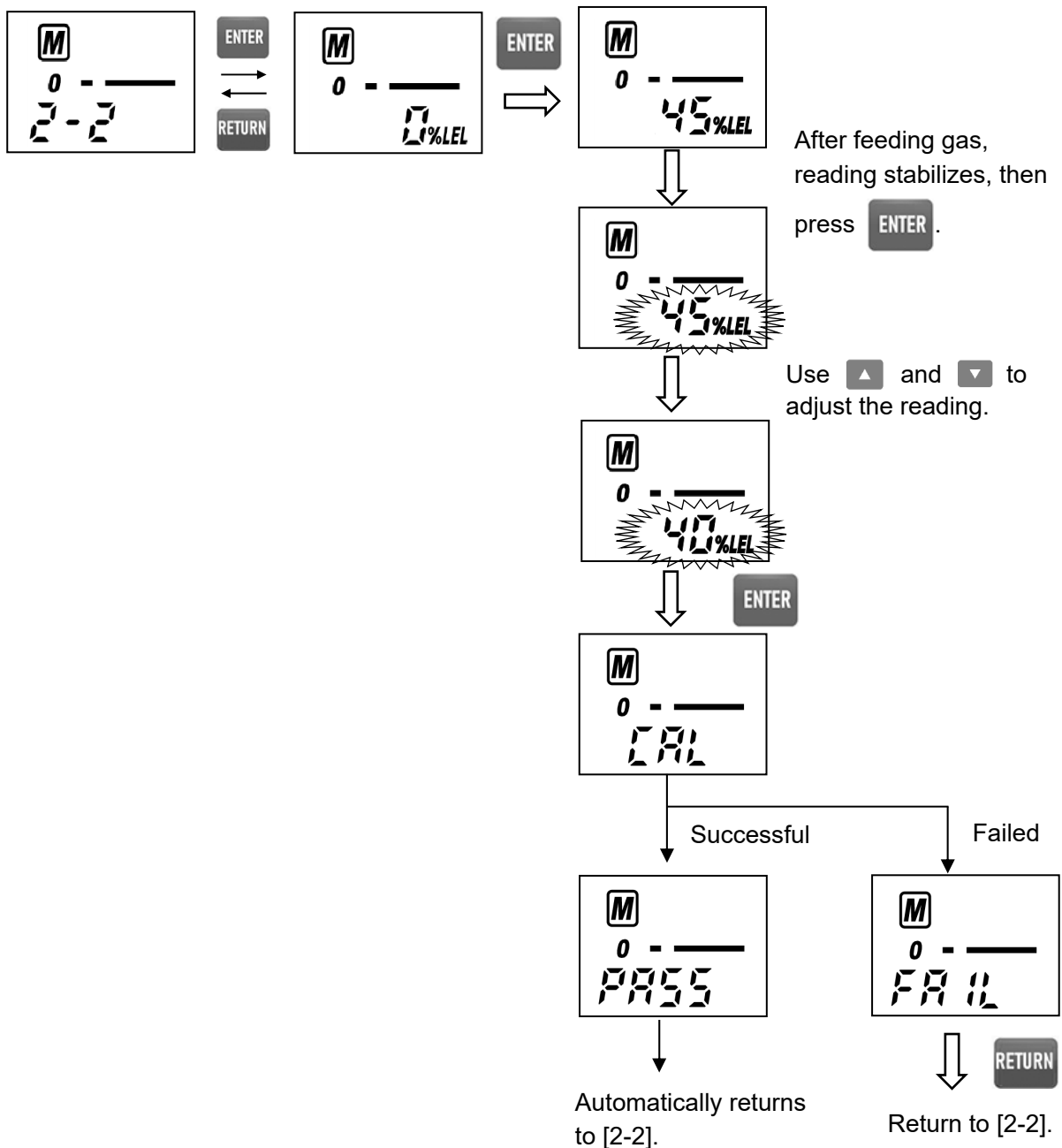

<2-4 Environmental settings 1>

Environmental settings 1 is used to set the various functions. (* We recommend keeping a record of the history when changing settings.)

Environmental settings 1 includes setting menus that are not normally used. Be careful to avoid accidentally changing the settings.

2-4

Press the ENTER button.

2-4.0

Sets the operation when switching to UPS operation with a UPS-equipped model. Use the ▲ and ▼ buttons to select one of the following:

- [on] (continuous operation)
- [oFF] (off)
- [30it] (30 minutes continuous measurement followed by intermittent measurement*)
- [30oF] (30 minutes continuous measurement followed by intermittent measurement)

Then confirm by pressing the ENTER button.

* Preset at the factory and not normally used by the user.

2-4.1

Not used

2-4.2

Sets the alarm value.

2-4.3

Sets the alarm delay time.

Use the ▲ and ▼ buttons to select the required value (in seconds), then press the ENTER button to set.

(Setting range: 0 - 60)

2-4.4

The screen for setting the alarm pattern.

This affects the device operation. Do not alter for normal use.

(Default setting: Self-latching [L])

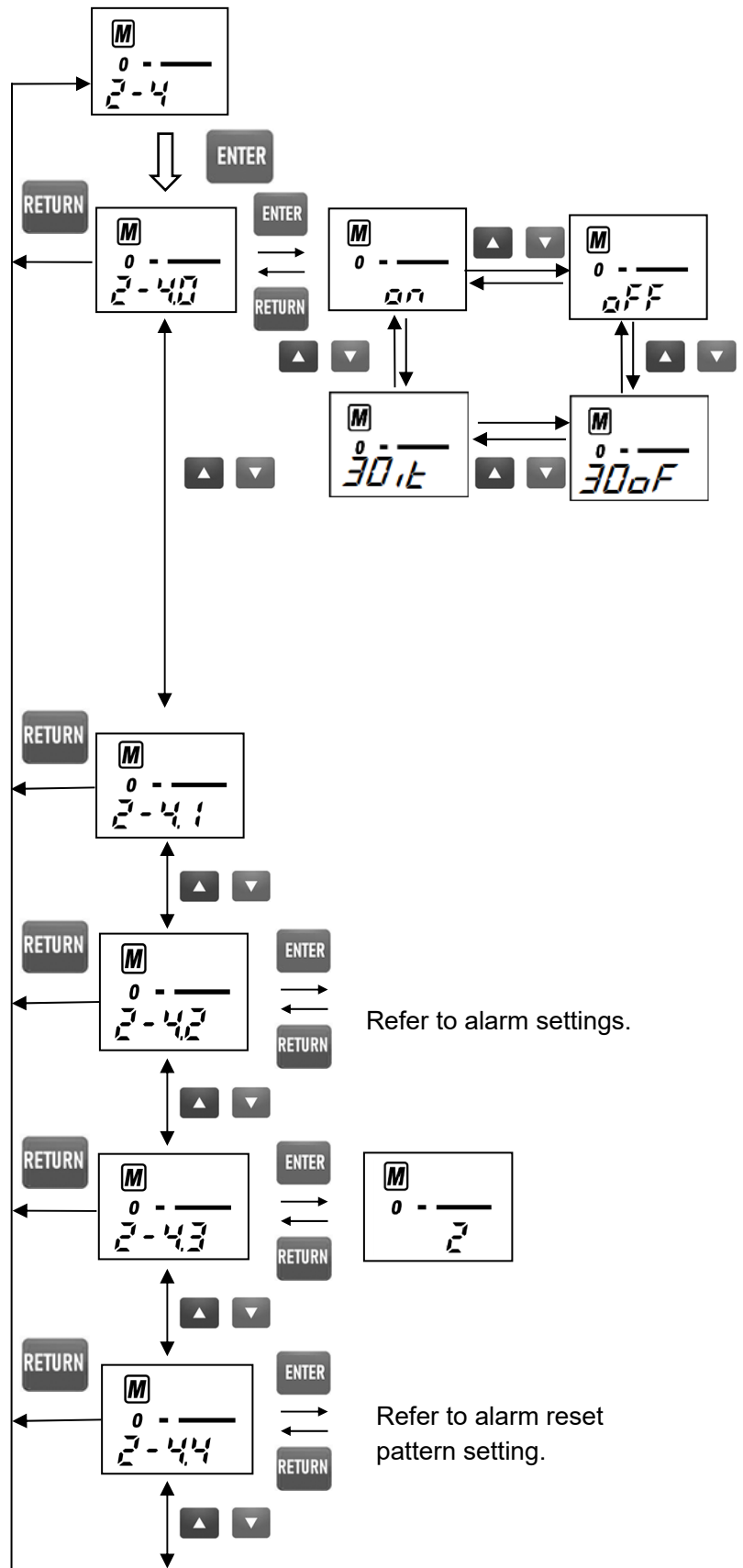

2-4.5

Sets the suppression type.
Use the ▲ and ▼ buttons to select [CUT] or [SLOP], then press the ENTER button to set.
Setting [CUT] (cutoff) displays values exceeding the suppression value directly.
Setting [SLOP] (slope) displays values exceeding the suppression value smoothly.

2-4.6

Sets the suppression value.
Use the ▲ and ▼ buttons to select the required value, then press the ENTER button to set.

2-4.7

Sets the individual alarm contact ②.
Use the ▲ and ▼ buttons to select [AL] (gas alarm contact) or [FAU] (fault alarm contact), then press the ENTER button to set.

2-4.8

Sets the individual alarm contact to energized or de-energized.

2-4.9

Not used

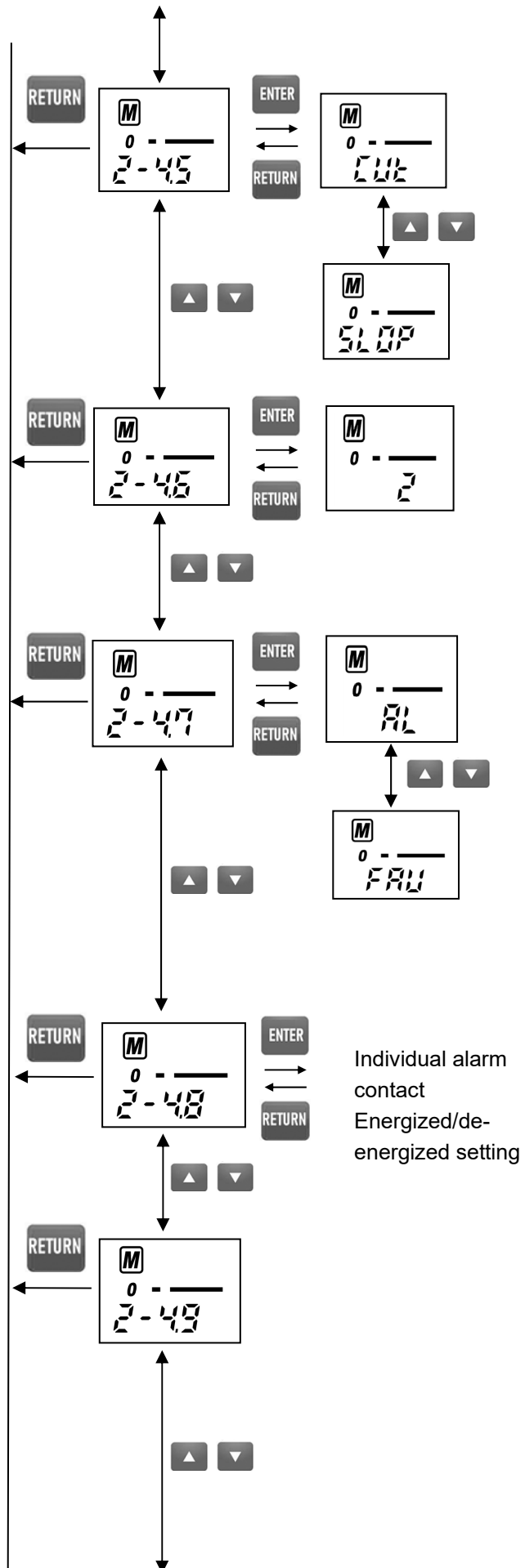

2-4.A

Not used

2-4.B

Not used

2-4.C

Not used

2-4.D

Sets the contact operation during alarm tests. Use the ▲ and ▼ buttons to select [on] or [oFF], then press the ENTER button to set. When set to [on], individual alarm contacts operate during alarm testing.

2-4.E

Sets whether or not a password is used.

2-4.F

Screen for setting the sensor fault resetting method. This affects the device operation. Do not alter for normal use. (Default setting: Auto-reset [nL])

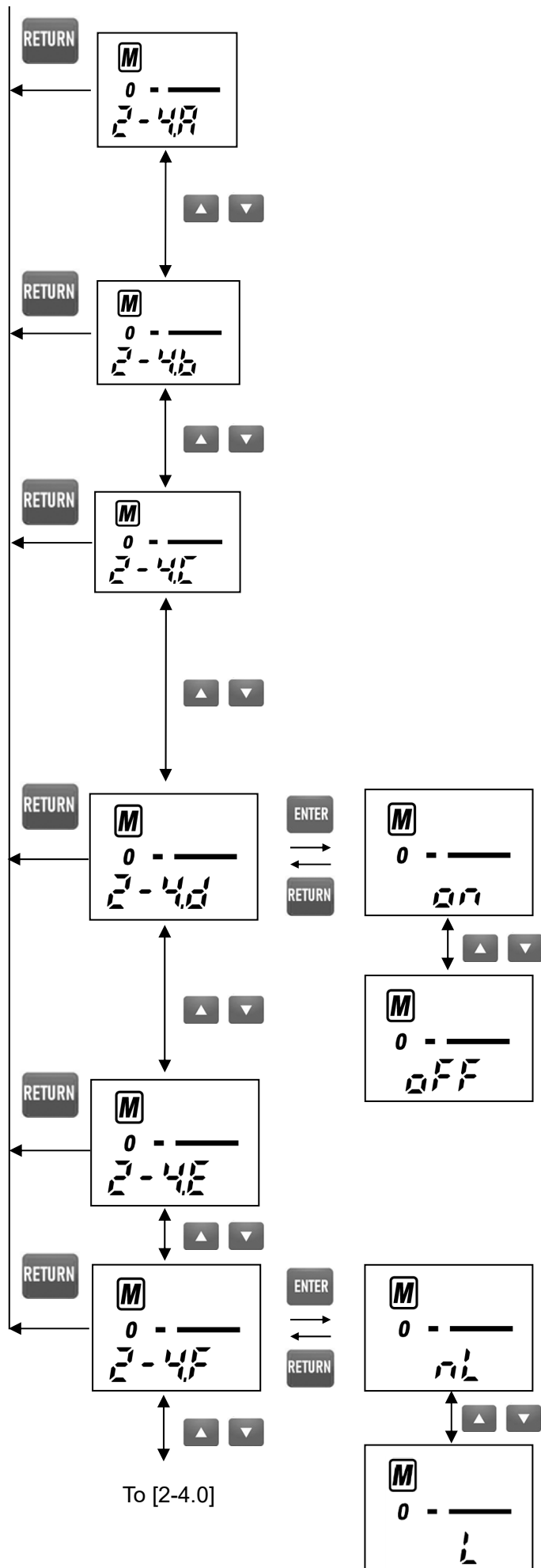

<2-4.0 Intermittent measurement>

Selecting intermittent measurement after 30 minutes of continuous operation for the UPS operation setting will result in intermittent measurement, but this enables the operation time using the UPS to be extended. The on/off time settings for intermittent measurement are as follows:

<Intermittent measurement after 30 minutes continuous measurement>

Measurement on time: Determined for each sensor. Settings cannot be changed.
(HW-6239: 30 s, other sensors: 15 s)

Measurement off time: Select from 10/30/60/90 mins.

After 30 minutes elapse after switching to the UPS, all of the lamps on the buzzer unit switch to blinking (two seconds on/two seconds off) to save energy.

Intermittent measurement (example)

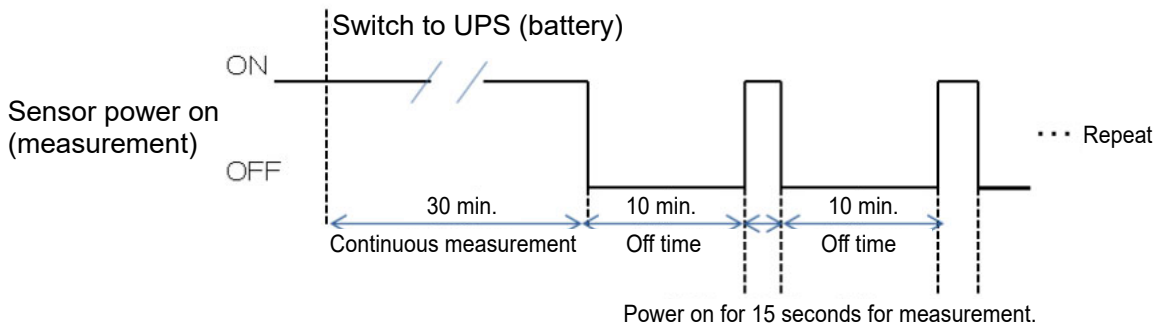

[intr] is displayed for those channels using intermittent measurement (figure on right), and the POWER lamp blinks.

The LCD screen brightness is also reduced to save energy.

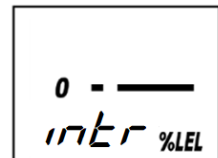

If a gas is detected above the alarm setpoint level (or if a fault is detected), the system will switch to an alarm state, all channels will switch to continuous operation mode, and an alarm will be issued.

With suction type models, the pump operates continuously, so no energy saving benefits are obtained even by setting intermittent measurement. Similarly, flame detectors do not support intermittent measurement.

For a guide to the approximate continuous operation time using intermittent measurement, refer to the appendix.

<2-4.2 Alarm settings>

- ① Select [2-4.2] on the menu screen.
- ② Press the ENTER button.
- ③ Use the ▲ and ▼ buttons to select the alarm value.
(Setting range: 10 - 100)
- ④ Press the ENTER button to store the setting.
The display automatically returns to [2-4.2] after setting.

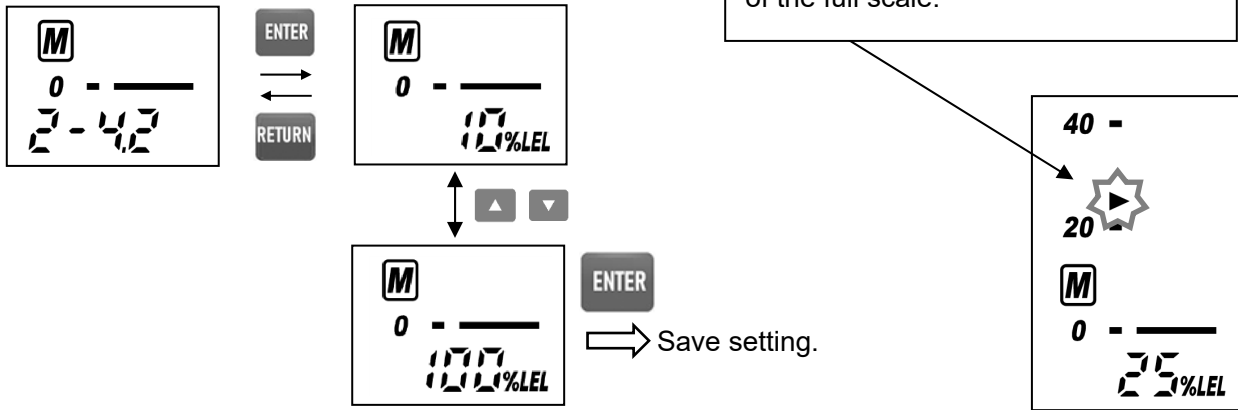

<2-4.4 Alarm pattern>

- ① Select [2-4.4] on the menu screen.
- ② Press the ENTER button.
- ③ Use the ▲ and ▼ buttons to select [L] or [nL]
- ④ Press the ENTER button to store the setting.
The display automatically returns to [2-4.4] after setting.

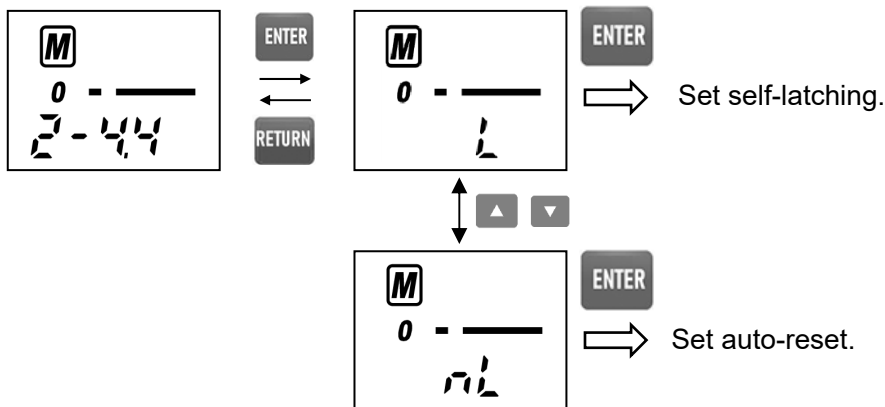

<2-4.8 Alarm contact energized/de-energized setting>

- ① Select [2-4.8] on the menu screen.
- ② Press the ENTER button.
- ③ Use the ▲ and ▼ buttons to select [E-C] (individual alarm contact ①) or [AL-C] (individual alarm contact ②).
- ④ the ▲ and ▼ buttons to select [nd] (de-energized) or [nE] (energized).
- ⑤ Press the ENTER button to store the setting.
The display automatically returns to [2-4.8] after setting.

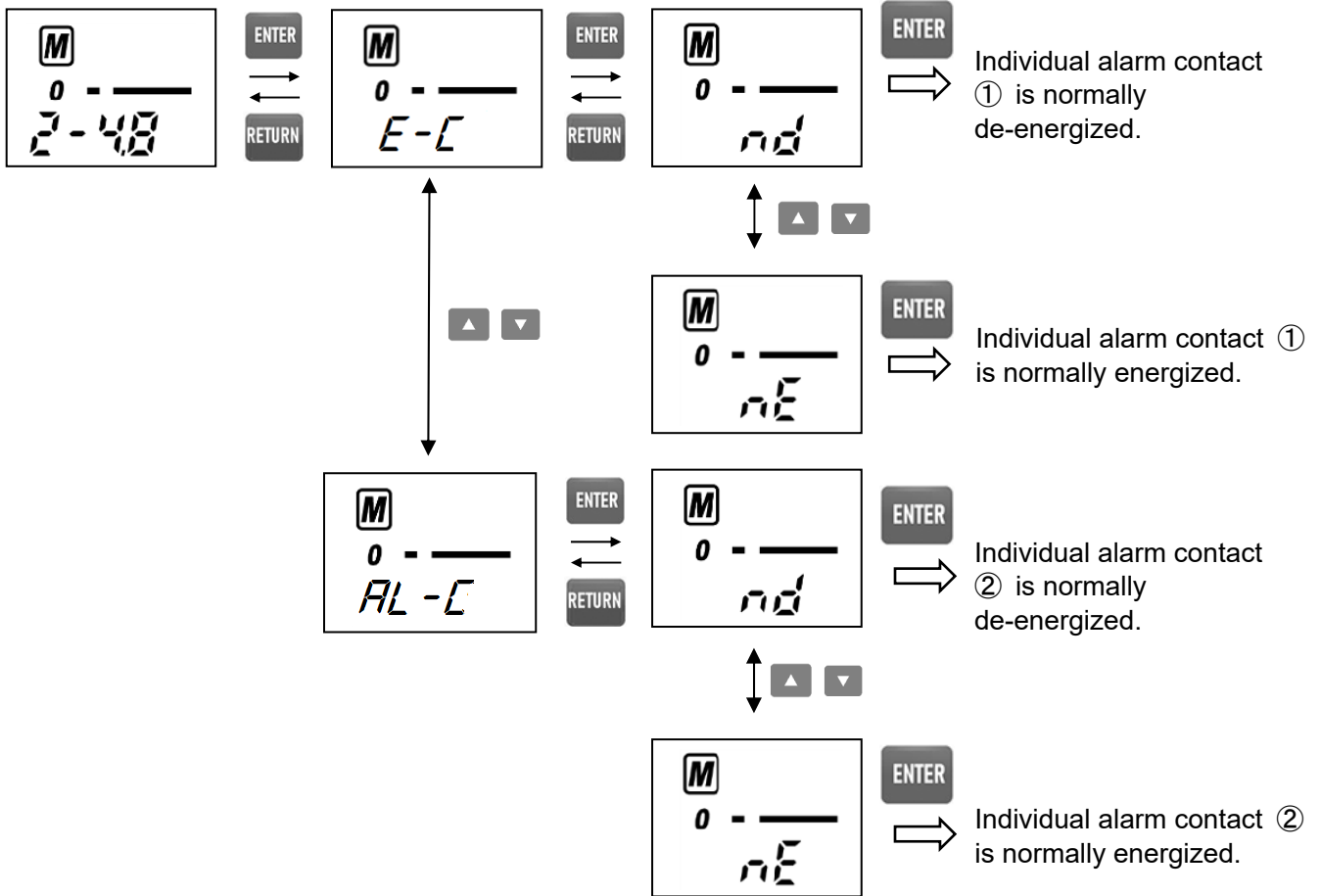

***NOTE**

- Setting to de-energized energizes the relay in the alarm state. (De-energized in normal state)
- When using a contact, the setting is open under normal conditions and closed in the alarm state.
 - This behavior is reversed with b contact.

- Setting to energized energizes the relay in normal state. (De-energized in alarm state)
- When using a contact, the setting is closed in normal conditions and open in the alarm state. It will also open when the power supply is turned off.
 - This behavior is reversed with b contact.

***NOTE**

If you wish to alter the contact specification (a or b contact) settings, contact RIKEN KEIKI.

<Environmental settings 2>

Environmental settings 2 is used to set the various functions. (* We recommend keeping a record of the history when changing settings.)

Environmental settings 2 includes setting menus that are not normally used. Be careful to avoid accidentally changing the settings.

2-5
Press the ENTER button.

2-5.0
Adjusts heater current.

2-5.1
Not used

2-5.2
Selects the detector type and selects the target gas for the gas detector.

2-5.3
Alarm value limiter setting screen.
Do not alter for normal use. (Default setting: ON)

2-5.4
Sets the fault delay time.
Use the ▲ and ▼ buttons to select the required value (in seconds), then press the ENTER button to set.
(Setting range: 0 - 60)

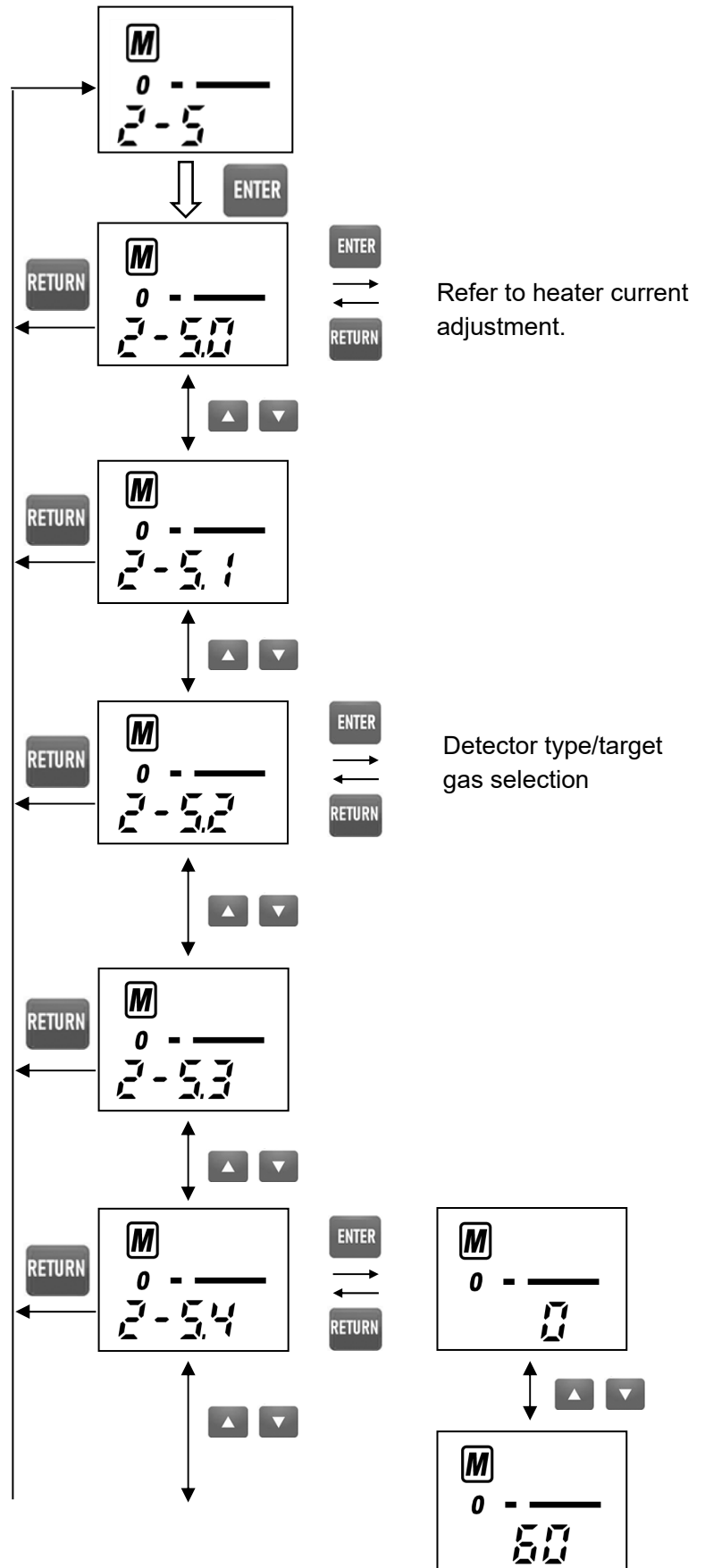

Refer to heater current adjustment.

Detector type/target gas selection

2-5.5

Sets the fault buzzer.

Use the ▲ and ▼ buttons to select [on] or [oFF], then press the ENTER button to set. When [on] is selected, the buzzer sounds when a fault occurs.

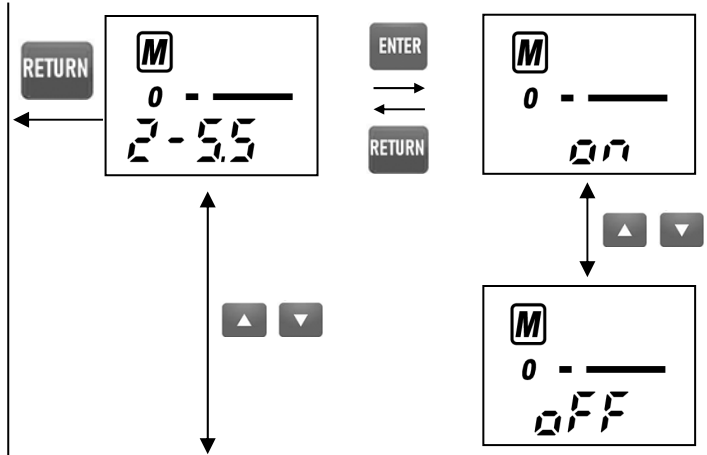

2-5.6

Enables and disables the zero follower function. Setting the time enables the function.

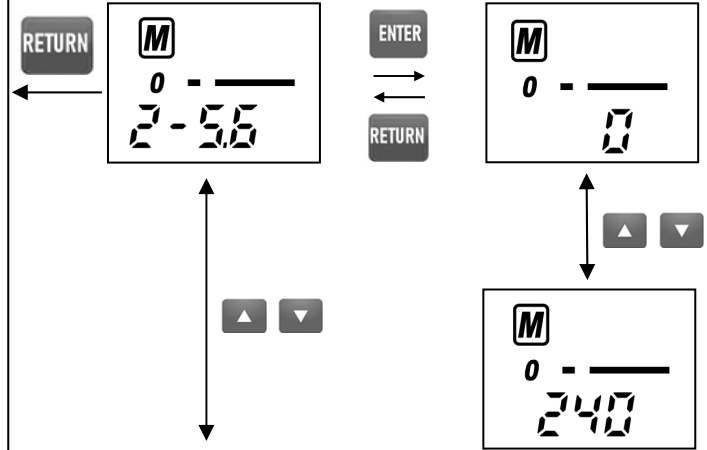

2-5.7

Adjusts the LCD backlight (green) brightness. Use the ▲ and ▼ buttons to select the required value, then press the ENTER button to set.

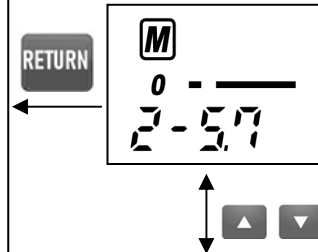

2-5.8

Adjusts the LCD backlight (red) brightness. Use the ▲ and ▼ buttons to select the required value, then press the ENTER button to set.

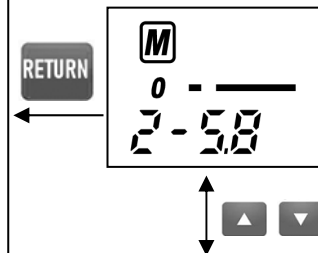

2-5.9

Sets the off time (time for which no measurements are performed) used when intermittent measurement after 30 minutes of continuous measurement has been selected in UPS operation [2-4.0]. Use the ▲ and ▼ buttons to select the required value (in minutes), then press the ENTER button to set.

Increasing this time extends the continuous operating time.

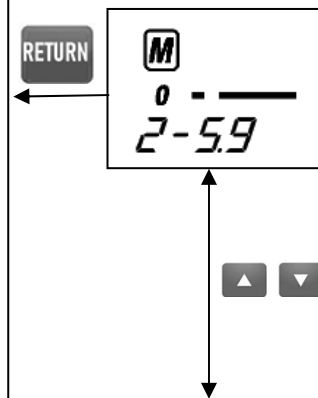

* Preset at the factory and not normally used by the user.

2-5.A

Not used

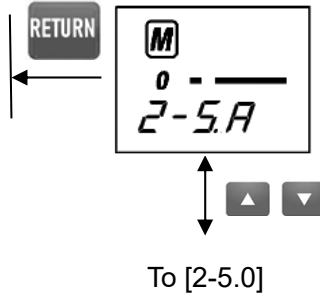

For more information, refer to '[2-4.0]'.

<2-5.0 Heater current adjustment procedure>

CAUTION

- Perform before gas adjustment (zero/span adjustment) after replacing a sensor.
- Be sure to check that the target gas is not present before performing zero adjustment after turning the power back on again and after recovering from a power failure.
- If [E-1] is displayed after initialization, either turn the power off and then back on again, or adjust the heater in maintenance mode [2-5.0].

- ① Select [2-5.0] on the menu screen.
- ② Press the ENTER button.
- ③ The heater current is adjusted automatically.
- ④ Press the ENTER button after adjustment to return to [2-5.0].

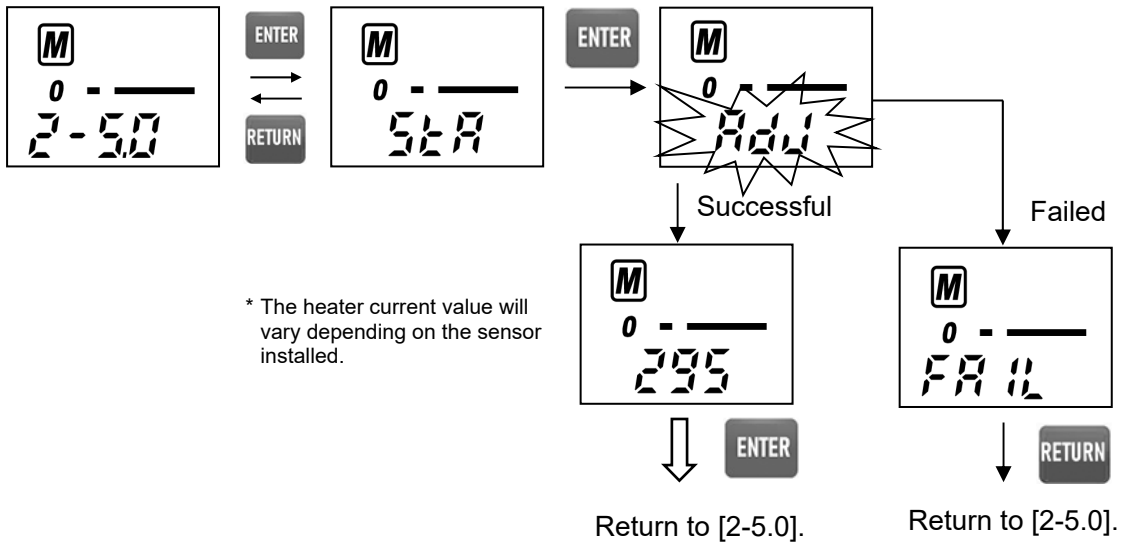

<2-5.2 Detector type/gas number selection>

- ① Select [2-5.2] on the menu screen.
- ② Press the ENTER button.
- ③ Use the ▲ and ▼ buttons to select [GAS] (gas detector) or [FirE] (flame detector).
If [GAS] is selected, use the ▲ and ▼ buttons to select the gas number.
(Setting range: 0 -)
- ④ Press the ENTER button to store the setting.
The display automatically returns to [2-5.2] after setting.

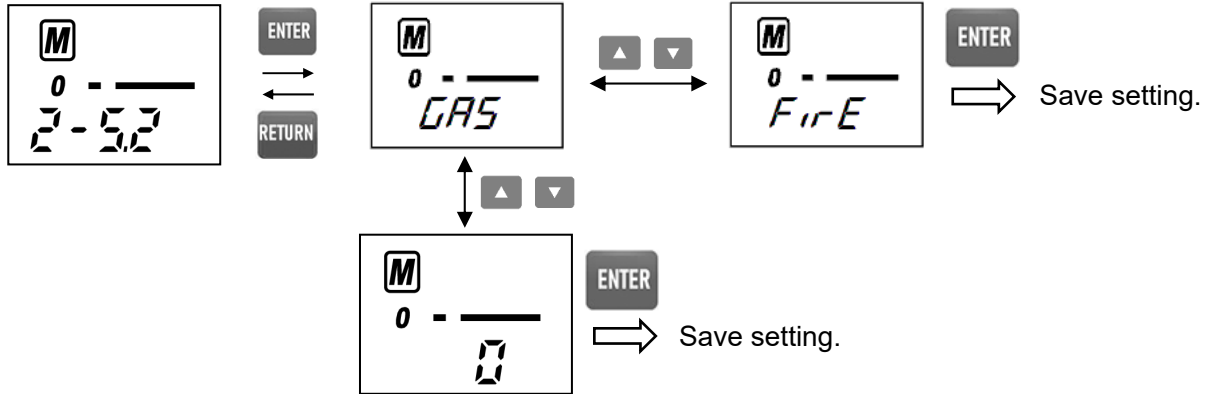

⚠ CAUTION

- Be sure to remove the sensor before changing the gas number. Turn off power after setting before connecting the sensor. This will prevent damage to the sensor.
- If a flame detector is selected, menus related to gas detection settings in the maintenance menu will be disabled (i.e., they cannot be set).
- Jumper settings on the circuit board are needed when using a flame detector. Please contact RIKEN KEIKI for more information.

<Display items>

2-6

Press the ENTER button.

2-6.0

Displays the heater current.
Pressing the ENTER button displays the current heater current.

2-6.1

Displays the fault details in the form of an error code.

2-6.2

When a flame detector is connected, the 0 - 20 mA level is displayed.

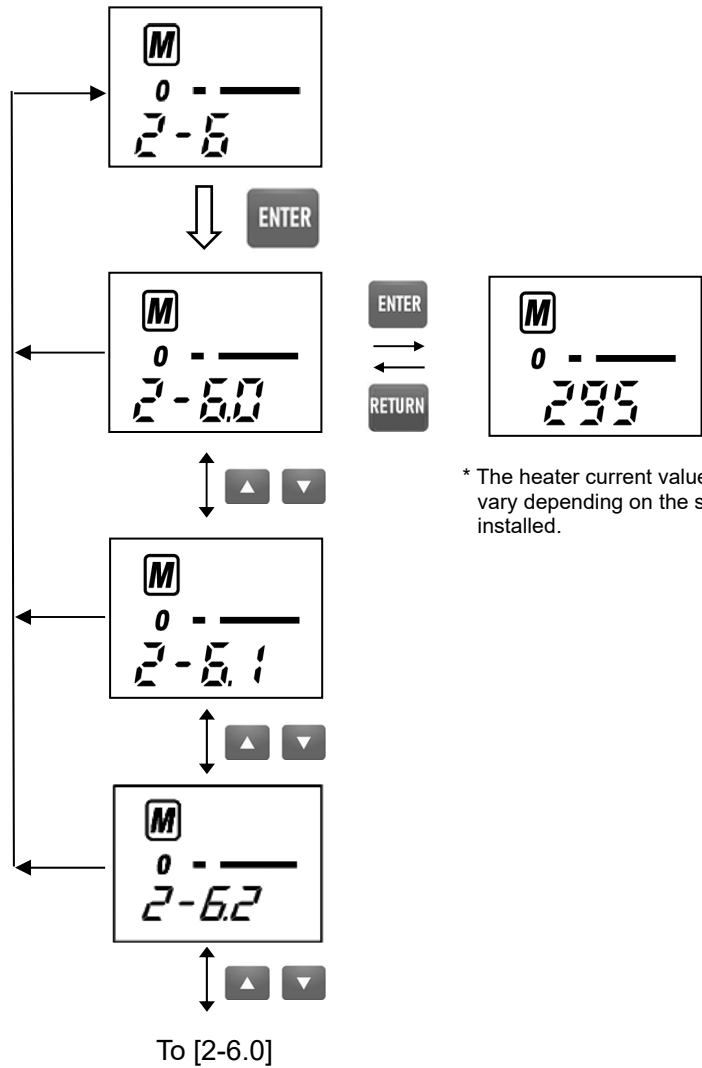

8. Storage, Relocation, and Disposal

8-1. Procedure for storage or for extended periods without use

Store the product under the following conditions:

- At normal temperature and humidity in a location not exposed to direct sunlight
- In a location free of gases, solvents, and vapors
- In a location free of vibration and impact

8-2. Procedures for relocation or reuse

When relocating the product, make sure that the new location conforms to the details described in '4-2. Precautions regarding installation location' and '4-5. Installation procedure'.

Also refer to '4-7. Wiring' for information on wiring installation. Try to minimize the time for which the detector (sensor) and indicator are unpowered when relocating.

CAUTION

Calibration must be performed before reusing a relocated product or a product that was previously stopped and stored. Contact RIKEN KEIKI for readjustments, including calibration.

8-3. Product disposal

Dispose of the product as industrial waste (incombustible) in accordance with local regulations.

9. Troubleshooting

This troubleshooting section does not cover the causes of all problems that may occur with the product. It provides brief explanations to assist in determining the causes of common problems.

If you encounter symptoms not addressed here or if problems persist even after taking corrective action, contact RIKEN KEIKI.

*NOTE

Also refer to the operating manuals for the detectors connected to the product.

- : Lamp lit
- : Lamp unlit

<Product abnormalities>

Symptom/Display	FAULT lamp	Cause	Action
<u>The power cannot be turned on.</u>	—	The power switch is turned off.	Turn on the power switch.
		A fuse has blown.	Investigate the cause of the blown fuse, take preventive action, and replace the fuse.
		The power supply cable is incorrectly connected.	Check the terminal board and reconnect correctly.
		Abnormalities or instantaneous interruptions in the power supply circuit	Supply the rated voltage. Review the uninterruptible power source, power line filter, and insulating transformer, then take additional necessary measures.
		Cable abnormality (disconnection, loose connection, short circuit)	Check the wiring for this product and the related devices in the vicinity.
<u>Abnormal operation</u>	○	Effects of sudden surge noise, etc.	Turn off the power and restart. If this symptom occurs frequently, take appropriate measures to address the noise source.
<u>Span adjustment is not possible.</u>	○	Calibration gas concentration	Prepare appropriate calibration gas.
		The sensor sensitivity has degraded.	Replace the sensor.
<u>Sensor abnormality</u> E-1	●	Sensor disconnection or short circuit inside the detector Heater adjustment abnormality	Connect the cable correctly between the product and the detector (sensor), or replace the sensor. If [E-1] is displayed after initialization, turn the power off and then back on again, or adjust the heater in maintenance mode [2-5.0].
<u>System abnormality</u> E-9	●	Abnormality in memory inside the detector	Contact RIKEN KEIKI.

<Reading abnormalities>

Symptom	Cause	Action
<u>The reading does not return to normal levels after rising (or falling)</u>	Sensor drift	Perform zero adjustment.
	Presence of interference gases	It is difficult to completely eliminate the effects of interference gases such as solvents. Contact RIKEN KEIKI for information on countermeasures, such as interference gas removal filters.
	Slow leakage	Trace amounts of the detection target gas may be leaking (slow leakage). Leaving this unchecked may result in hazards. Take the same action as in the event of a gas alarm.
	Environmental fluctuations	Perform zero adjustment.
<u>A gas alarm is issued despite the absence of a gas leak or other abnormalities at the detection point.</u>	Presence of interference gases	It is difficult to completely eliminate the effects of interference gases such as solvents. Contact RIKEN KEIKI for information on countermeasures, such as interference gas removal filters.
	Effects of noise	Turn off the power and restart. If this symptom occurs frequently, take appropriate measures to address the noise source.
	Sudden environmental changes	If the environment (e.g., temperature) changes suddenly, the product may not respond adequately. In certain cases, a reading alarm may be issued. The product cannot be used if sudden environmental changes occur frequently. Take appropriate action.
<u>Slow response</u>	Clogged dust filter	Replace the suction type detector or calibration gas pump dust filter.
	Bent or blocked inlet or outlet tube	Repair the location affected by the problem (suction type detector or calibration gas pump).
	There is condensation inside the inlet tube.	Repair the location affected by the problem (suction type detector or calibration gas pump).
	The sensor sensitivity has degraded.	Replace with a new sensor.
<u>Span adjustment is not possible.</u>	The calibration gas concentration is inappropriate.	Prepare appropriate calibration gas.
	The sensor sensitivity has degraded.	Replace with a new sensor.

10. Product Specifications

10-1. Specifications

- Construction: Wall-mounted or rack-mounted, non-explosion-proof construction
- Paint color: Lower door: Light gray (Munsell N7.2)
Other parts: Black
- UPS: Yes or no
- External dimensions/weight:
 - 2-point type: Approx. 305 mm (W) × 290 mm (H) × 73 mm (D), approx. 3.8 kg
 - 4-point type: Approx. 395 mm (W) × 290 mm (H) × 73 mm (D), approx. 4.9 kg
 - 6-point type: Approx. 485 mm (W) × 290 mm (H) × 73 mm (D), approx. 5.9 kg
 - 8-point type: Approx. 575 mm (W) × 290 mm (H) × 73 mm (D), approx. 6.4 kg
 - 10-point type: Approx. 665 mm (W) × 290 mm (H) × 73 mm (D), approx. 7.1 kg
 - 12-point type: Approx. 755 mm (W) × 290 mm (H) × 73 mm (D), approx. 7.9 kg
- * Weights include the base unit (buzzer, 2-point type indicator, UPS battery) and indicator/alarm unit.

• Exterior drawings:

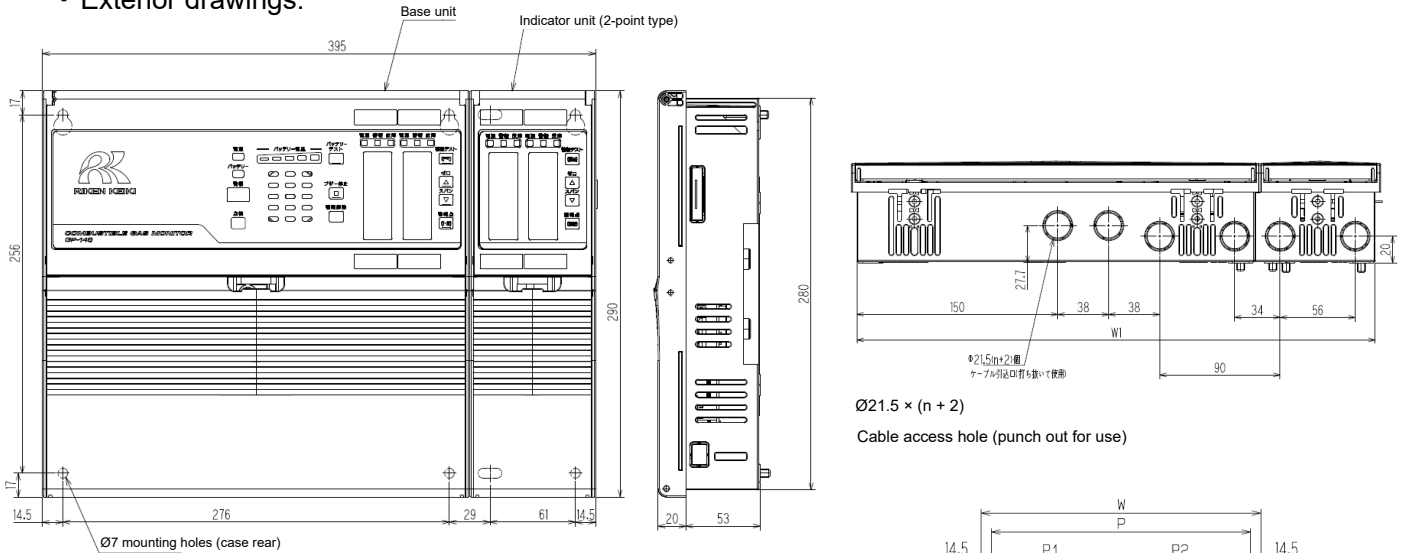

Number of points	W	W1	Mounting dimension		
			P	P 1	P 2
□	2	305	297	276	
□	4	395	387	366	
□	6	485	477	456	
□	8	575	567	546	
□	10	665	657	305	331
□	12	755	747	305	421

Wall mounting dimensions

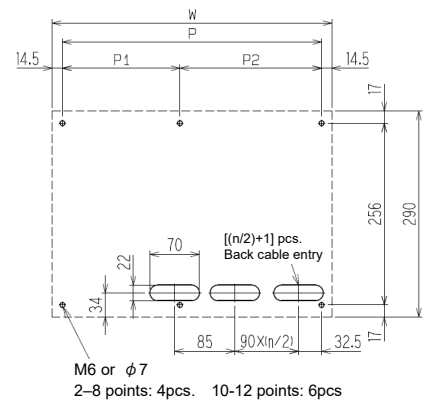

Number of points	Cutout hole dimension A
2	299
4	389
6	479
8	569
10	659
12	749

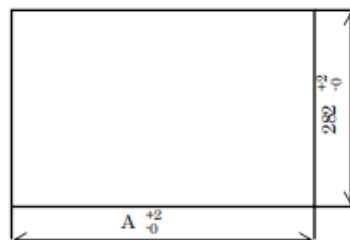

Rack mounting panel cutout dimensions

1. Base unit (including buzzer, 2-point type indicator, UPS battery)

- Construction: Modular type (up to five indicator units can be used together)
- General alarm contact output: No-voltage C contact (Contact capacity: 250 V AC, 2 A, resistance load)
- General alarm voltage output: Voltage for normal operation: 6 V (load current 10 mA or less)
Gas alarm: 12 V (load current 10 mA or less)
Trouble: 0 V
- External buzzer contact output: No voltage a or b contact
(Contact capacity: 250 V AC, 1 A (resistance load))
- External buzzer power supply output: 24 V DC (load current 10 mA or less)
- Display: Character LCD (red/green two-color bar meter display)
Lamps (power lamp (green), battery lamp (orange), alarm lamp (red))
Battery level meter (five LED lamps)
Automatically illuminates when switching from mains power supply to UPS power supply
- Alarm type: Alarm lamps, self-latching, buzzer (optional voice alarm)
- Power supply input: 100 - 120 V AC or
200 - 240 V AC (50/60 Hz)
- Operating temperature/humidity range: -10 - +50 °C (no sudden fluctuations), 10 - 90 %RH (no condensation)
* Operating ambient humidity for the optional voice unit is 85 %RH or less.
- Detection operation using UPS: Continuous detection (continuous power supply), off, intermittent measurement after 30 mins of continuous measurement, or off after 30 mins of continuous measurement
- External connection terminals: 13 pins (one pin not used)

Power input	3 pins
General alarm contact output	3 pins
General alarm voltage output	2 pins
External buzzer contact output	2 pins
External buzzer power supply output	2 pins
Unused terminal	1 pin

2. UPS battery

- Construction: Modular type (up to five indicator units can be used together)
- Batteries: Lead storage batteries: 12 V, 2.3 Ah × 2
- Other functions: Over-discharge protection circuit
- UPS operating time: Depends on detector and settings. Refer to the appendix.

UPS operating time (continuous operation)

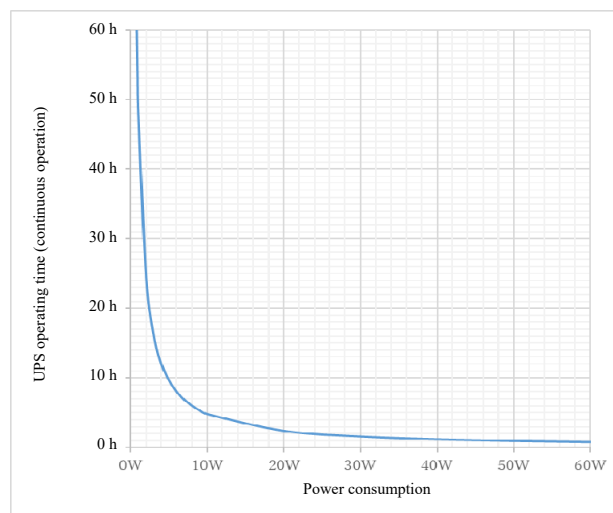

3. Indicator unit

- Construction: 2-point type (individual unit), modular type
- Concentration display type: Character LCD (red/green two-color bar meter display)
- Individual alarm contact output: No voltage a or b contact
(2-point type) (Contact capacity: 250 V AC, 2 A (resistance load))
- External connection terminals: 10 pins
 - Detector input/output 4 pins
 - Pump and flame detector (option) power supply output (24 V DC) 2 pins
 - Individual alarm contact output 1 (Gas alarm) 2 pins
 - Individual alarm contact output 2 (Gas alarm or fault alarm) 2 pins
- Alarm delay: Two seconds or up to 60 seconds in one second increments
- Other functions:
 - <Alarm test> Alarm operation check
 - <Gas concentration peak display>
 - Gas concentration peak value retained on bar meter display when gas concentration exceeds alarm setting.
- Power supply: Supplied from base unit
- Cables between detectors: CVV 4-core or equivalent cable
- Transmission distance between detectors:
 - Max. 300 m using CVV (0.75 mm²) cable
 - Max. 500 m using CVV (1.25 mm²) cable
 - Max. 500 m using CVV (2.0 mm²) cable
 - * For more information on the flame detector (40/40 series) connection, refer to the operating manual.

10-2. Accessory list

- Operating manual: × 1
- Rack mounting fittings: Number included will differ depending on number of units.
(Provided only with rack-mounted type)

2- to 8-point type	× 4
10/12-point type	× 6

11. Terminology

%LEL	The concentration of a combustible gas expressed as a percentage of the lower explosive limit of the combustible gas. The lower explosive limit (LEL) is the minimum concentration of a combustible gas mixed in air at which ignition will result in explosion.
ppm	Indicates gas concentration in units of parts per million by volume.
Calibration	Determining correlation between product readout values, display values, and setting values with actual values using calibration gas.
Maintenance mode	During product maintenance, the alarm contacts are cut off, and the external output signal outputs a signal indicating the product is in maintenance mode. This enables the device to be isolated for maintenance.
Initialization	During the few seconds after turning on the power, the readings are unstable. Alarm contacts are cut off during this time to prevent errors. The external output sends a signal indicating the product is in initialization mode.
Zero suppression	This function makes fluctuations in ambient conditions and interference gas less noticeable.
Alarm delay time	This is the function for temporarily suspending activation to prevent false alarms caused by external noise.
Alarm delay time	The time until an alarm occurs when gas is provided at 1.6 times the alarm setpoint. (This excludes pipe-related delays when connected to external suction piping.) The maximum alarm delay time for the product is 30 seconds.
Inhibit	This temporarily suspends the gas detection function during product maintenance. This is also called "point skip," which has the same function.

* Appendix Power consumption calculation method and UPS operating time quick referral table

The power consumption for the GP-148 can be calculated using the following table as a guide:

(1) Power consumption for commercial power supply to main unit (VA)

	Item	Continuous detection
A	Base unit * Including indicator unit (two channels per unit)	15.3 (VA)
B	Indicator/alarm unit (two channels per unit)	1.3 (VA)
C	Isobutane sensor (HW-6211/NC-6211)	3.8 (VA)
D	Methane sensor (HW-6239/NC-6239)	2.8 (VA)
E	Hydrogen sensor (NC-6244A)	1.8 (VA)
F	Suction type detector (DC model)	33.0 (VA)
G	Flame detector (Sharp Eye 40/40 Series)	34.0 (VA)
H	Charging operation for UPS (battery)-equipped model	17.3 (VA)

(2) Power consumption when using UPS battery (W)

	Item	Continuous detection
A	Base unit * Including indicator unit (two channels per unit)	0.3 (W)
B	Indicator/alarm unit (two channels per unit)	0.2 (W)
C	Isobutane sensor (HW-6211/NC-6211)	1.3 (W)
D	Methane sensor (HW-6239/NC-6239)	1.0 (W)
E	Hydrogen sensor (NC-6244A)	0.7 (W)
F	Suction type detector (DC model)	8.7 (W)
G	Flame detector (Sharp Eye 40/40 Series)	9.6 (W)

[Calculation equation]

GP-148 (-point type)

Base unit and indicator unit

① **A** + **B** × _____ unit(s) (up to 5 units) = _____ (W)

Detector total: _____ units

Isobutane sensor

② **C** × _____ unit(s) = _____ (W)

Methane sensor

③ **D** × _____ unit(s) = _____ (W)

Hydrogen sensor

④ **E** × _____ unit(s) = _____ (W)

Suction type detector (DC model)

⑤ **F** × _____ unit(s) (up to 4 units) = _____ (W)

Flame detector

⑥ **G** × _____ unit(s) (up to 6 units) = _____ (W)

UPS charging (for UPS-equipped models)

⑦ **H**

Power consumption ①+②+③+④+⑤+⑥ = _____ (W)

Operating time using UPS

The table below lists the approximate operating times for continuous operation using the UPS under the following conditions.

Details are provided here for typical sensors. Please contact RIKEN KEIKI for more information.

Detector: HW-6211/NC-6211 (diffusion type)

Cable length: 1.25 sq/100 m

Battery: Fully charged state

Ambient temperature: 25 °C

Operation: No alarm activation

Intermittent measurement setting (15 seconds on/10 minutes off)

No voltage output load connected

HW-6211	Continuous operation	Intermittent measurement
2-point type	Approx. 16 hours	Approx. 136 hours
4-point type	Approx. 8 hours	Approx. 85 hours
6-point type	Approx. 5 hours	Approx. 60 hours
8-point type	Approx. 4 hours	Approx. 46 hours
10-point type	Approx. 3 hours	Approx. 37 hours
12-point type	Approx. 2 hours	Approx. 30 hours

Detector: HW-6239/NC-6239 (diffusion type)

Cable length: 1.25 sq/100 m

Battery: Fully charged state

Ambient temperature: 25 °C

Operation: No alarm activation

Intermittent measurement setting (30 seconds on/10 minutes off)

No voltage output load connected

HW-6239	Continuous operation	Intermittent measurement
2-point type	Approx. 20 hours	Approx. 123 hours
4-point type	Approx. 10 hours	Approx. 75 hours
6-point type	Approx. 6 hours	Approx. 53 hours
8-point type	Approx. 5 hours	Approx. 41 hours
10-point type	Approx. 4 hours	Approx. 33 hours
12-point type	Approx. 3 hours	Approx. 27 hours

Detector: NC-6244A (diffusion type, H₂/F.S. 2,000 ppm)

Cable length: 1.25 sq/100 m

Battery: Fully charged state

Ambient temperature: 25 °C

Operation: No alarm activation

Continuous operation setting

No voltage output load connected

NC-6244A	Continuous operation	Intermittent measurement
2-point type	Approx. 30 hours	—
4-point type	Approx. 15 hours	—
6-point type	Approx. 10 hours	—
8-point type	Approx. 7 hours	—
10-point type	Approx. 6 hours	—
12-point type	Approx. 5 hours	—

Revision History

Issue	Revision	Issue date
0	First issue (PT1-1170)	June 5, 2023
1	Appendix added; other minor corrections (PT1-1171)	December 13, 2023
2	Corrected weight	April 8, 2024
3	Corrected content regarding power supply for pumps	February 4, 2025