

**Portable Gas Detector  
GX-Force  
Operating Manual  
(PT0-210)**

**RIKEN KEIKI Co., Ltd.**

2-7-6 Azusawa, Itabashi-ku, Tokyo, 174-8744, Japan

Phone : +81-3-3966-1113

Fax : +81-3-3558-9110

E-mail : [intdept@rikenkeiki.co.jp](mailto:intdept@rikenkeiki.co.jp)

Web site : <https://www.rikenkeiki.co.jp/english/>

<b>Contents</b>	
1	Product Overview ..... 4
1-1	Introduction ..... 4
1-2	Intended use ..... 5
1-3	Checking the detection target gases and product type ..... 5
1-4	DANGER, WARNING, CAUTION, and NOTE ..... 6
1-5	Checking standards and explosion-proof specifications ..... 7
2	Important Safety Information ..... 8
2-1	Danger information ..... 8
2-2	Warnings ..... 9
2-3	Precautions ..... 10
2-4	Safety information ..... 12
3	Product Configuration ..... 15
3-1	Main unit and accessories ..... 15
3-1-1	Main unit ..... 15
3-1-2	Accessories ..... 16
3-1-3	Optional accessories ..... 16
3-2	Part names and functions ..... 18
3-2-1	Main unit ..... 18
3-2-2	LCD display ..... 20
4	Alarm Activation ..... 21
4-1	Gas alarm types ..... 21
4-2	Gas alarm setpoints ..... 21
4-3	Gas alarm patterns ..... 22
4-4	Fault alarm patterns ..... 24
5	Usage Instructions ..... 25
5-1	Usage note ..... 25
5-2	Preparations for startup ..... 25
5-2-1	Charging the lithium ion battery ..... 26
5-3	Startup procedure ..... 28
5-3-1	Turning on the power ..... 28
5-3-2	Screen transition from powering on to measurement mode ..... 29
5-4	Fresh air adjustment ..... 32
5-5	Gas detection ..... 33
5-5-1	Basic operating flow ..... 34
5-5-2	Measurement mode ..... 35
5-5-3	Snap log recording ..... 37
5-6	Turning off the power ..... 38
6	Setting Procedure ..... 39
6-1	Display mode ..... 39
6-1-1	Switching to display mode ..... 39
6-1-2	Contents displayed in display mode ..... 40
6-2	Display mode settings ..... 42
6-2-1	Light on/off ..... 42
6-2-2	Clearing PEAK value display ..... 42
6-2-3	Combustible gas conversion setting ..... 43
6-2-4	Adjustment data display ..... 46
6-2-5	Bump test data display ..... 47
6-2-6	Snap log data display ..... 48
6-2-7	Alarm setpoint display ..... 49
6-3	User mode ..... 50
6-3-1	Switching to user mode ..... 50
6-3-2	User mode setting items ..... 51
6-4	User mode settings ..... 53
6-4-1	Bump test ..... 53

6-4-2 Gas adjustment.....	53
6-4-3 Adjustment expiration setting .....	53
6-4-4 Bump test setting .....	57
6-4-5 Alarm setpoint setting .....	65
6-4-6 Lunch break on/off.....	68
6-4-7 Confirmation beep setting.....	69
6-4-8 LCD lighting time setting.....	72
6-4-9 Key operation tone on/off .....	72
6-4-10 Display mode item display on/off.....	73
6-4-11 Zero suppression on/off .....	74
6-4-12 Zero follower on/off .....	75
6-4-13 Date and time setting.....	76
6-4-14 Password setting .....	76
6-4-15 ROM/SUM display .....	77
7 Maintenance .....	78
7-1 Maintenance intervals and items.....	78
7-1-1 Maintenance service.....	79
7-2 Gas adjustment .....	80
7-2-1 Preparation for gas adjustment .....	80
7-2-2 Gas adjustment setting.....	82
7-2-3 Fresh air adjustment.....	84
7-2-4 AUTO adjustment .....	85
7-2-5 AUTO adjustment setting.....	88
7-3 Bump test.....	91
7-3-1 Performing bump test .....	91
7-4 Cleaning procedure .....	93
7-5 Parts replacement .....	94
7-5-1 Periodic replacement parts.....	94
7-5-2 Filter replacement.....	95
8 Storage and Disposal .....	97
8-1 Procedures for storage or when not in use for extended periods.....	97
8-2 Procedures for use after storage.....	97
8-3 Product disposal .....	98
9 Troubleshooting .....	99
9-1 Product abnormalities.....	99
9-2 Reading abnormalities.....	102
10 Product Specifications .....	103
10-1 Specifications list.....	103
10-1-1 Common specifications .....	103
10-1-2 Individual sensor specifications.....	105
10-2 Accessory list.....	107
11 Appendix .....	108
11-1 Data logger function.....	108
11-2 Methane gas sensitivity and response when using supplied or optional sampling probes .....	109
11-3 100 %LEL = ppm conversion list .....	110
11-4 Product warranty.....	111
11-5 Sensor warranty.....	111

---

# 1

---

# Product Overview

## 1-1 Introduction

Thank you for your purchase of the GX-Force Portable Gas Monitor (“the product” hereinafter). Before using the product, confirm that this operating manual covers the model you purchased.

The product should be used only by fully-trained personnel.

The maintenance procedures described in this manual should be performed only by fully-trained personnel. Any maintenance procedure not described in this manual must be performed by Riken Keiki or our certified service engineers. Please contact Riken Keiki.

This manual describes how to use the product and provides product specifications. Make sure you have read and fully understood the contents of this manual before using the product. This applies both to first-time users and those who have previously used the product.

Keep this manual in a handy place so that you can refer to it at any time.

Refer to the corresponding optional product manual when using the following optional product:

- SW-GX-Force Data Logger Management Program Software Operating Manual (PT0E-214)

Regardless of the warranty period, Riken Keiki does not accept any liability for accidents or damage resulting from use of the product. Be sure to read the warranty policy set forth on the warranty.

## 1-2 Intended use

The product is a gas detector designed to measure the concentrations of chemicals in the air in working environments.

It measures concentrations of toxic gases, combustible gases, and oxygen in the atmosphere and issues an alarm when preset alarm concentrations are reached, thereby alerting users to the hazards of explosion, gas poisoning, and oxygen deficiency.

The product can be equipped with up to three types of sensors to enable detection of up to four different gas types with a single unit.

## 1-3 Checking the detection target gases and product type

The product comes in several different types, depending on the combinations of detection target gases. Check the specifications before use to confirm the correct gases will be detected in accordance with the intended purpose.

The product type and detection target gas can be checked on the nameplate affixed to the side of the product.

The type is indicated by the suffix to the product model printed on the nameplate.

“H” (gas type is isobutane (HC)) or “M” (gas type is methane (CH<sub>4</sub>)) printed to the left of the QR code.

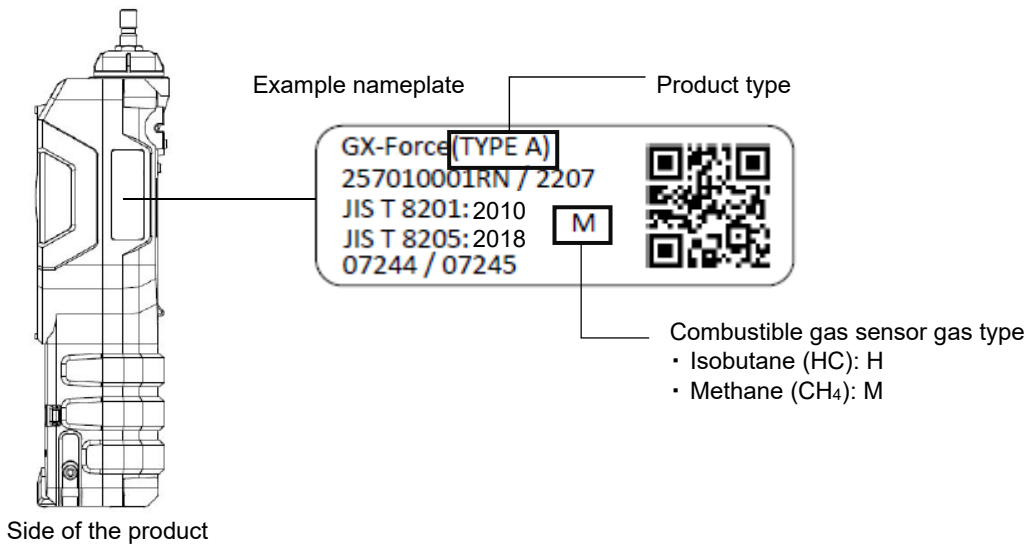



### <List of detection target gases (installed sensor models) by type>

Type	Detection target gases (installed sensor models)					
	Combustible gas HC or CH <sub>4</sub> (NCR-6309)	Oxygen (ESR-X13P)	Carbon monoxide/hydrogen sulfide (ESR-A1DP)	Hydrogen sulfide (ESR-A13i)	Carbon monoxide (ESR-A13P)	Carbon monoxide (ESR-A1CP)*
Type A	○	○	○			
Type B	○	○		○		
Type C	○	○			○	
Type CH	○	○				○
Type D	○	○				

\* The carbon monoxide sensor (ESR-A1CP) includes a correction function to reduce hydrogen interference. This function works for hydrogen concentrations up to 2,000 ppm. (However, if used in an environment exceeding 40°C for more than 15 minutes, it may be affected by hydrogen interference and may indicate a higher carbon monoxide concentration than actual.)

## 1-4 DANGER, WARNING, CAUTION, and NOTE

This operating manual uses the following categories to indicate potential damage/hazards if the user disregards the information provided and uses the product incorrectly:

 <b>DANGER</b>	This indicates situations in which improper handling may result in fatal or serious injury or significant property damage.
 <b>WARNING</b>	This indicates situations in which improper handling may result in serious injury or significant property damage.
 <b>CAUTION</b>	This indicates situations in which improper handling may result in minor injury or minor property damage.

Additionally, usage recommendations are indicated as follows:

<b>NOTE</b>	This indicates items that will be helpful to know when using the product.
-------------	---

## 1-5 Checking standards and explosion-proof specifications

The product specifications will vary depending on the specific standards and explosion-proof certification. Check the actual product specifications before use. For CE marking models, refer to the 'Declaration of Conformity' at the end of this operating manual.

Check the affixed nameplate for product specifications.

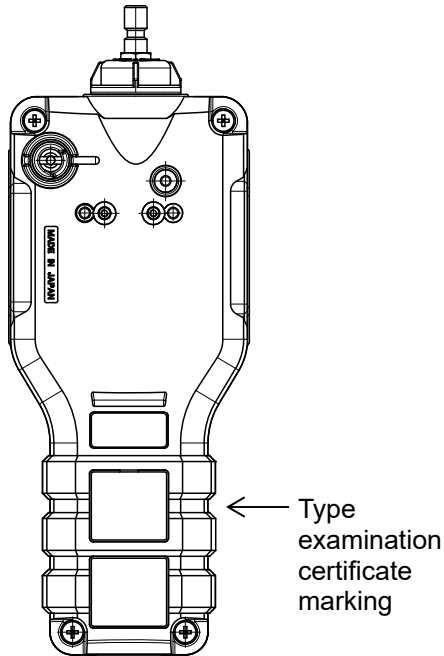

Typical nameplate for Japan EX specifications

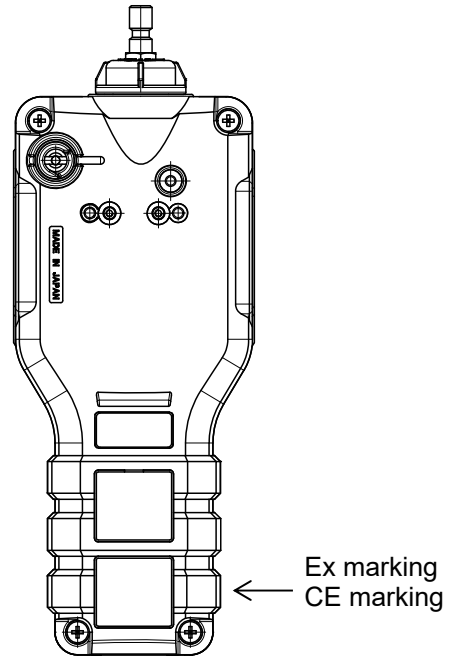

Typical nameplate for ATEX/IECEX specifications

---

## 2

---

# Important Safety Information

To maintain the performance of the product and to ensure safe use, always observe the following DANGER, WARNING, and CAUTION instructions.

## 2-1 Danger information



### Explosion-proofing

- Do not modify or alter the circuits or configuration.
- When measuring oxygen concentrations, measure only mixtures of air and combustible gas or toxic gas.  
Do not use the oxygen sensor to detect leaks of combustible or toxic gases.
- When using the product in hazardous areas, the following precautions must be observed to safeguard against static electricity hazards:
  - ① Wear anti-static clothing and conductive shoes (anti-static work shoes).
  - ② When using the product indoors, stand on a conductive work floor (with a leakage resistance of 10 MΩ or less).

- The ratings are as follows:

Power supply battery pack (BP-Force): 3.6 V DC, 200 mAh

Battery charging contact allowable voltage: 6.0 V DC (with SELV power supply only)

Ambient temperature: -20 °C - +60 °C

(Ambient temperature refers to the temperature range in which the explosion-proof performance can be maintained. It does not refer to the temperature range in which product performance is guaranteed. For information on the operating temperature range, refer to '10-1 Specifications list'.)

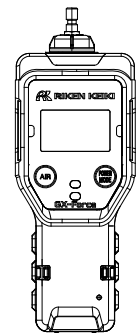

Main unit

### Usage

- If measuring inside manholes or enclosed spaces, never lean over or look into the manhole or enclosed space. There is a danger that oxygen-deficient air or other gases may be discharged from such locations.



## 2-2 Warnings



### WARNING

#### If an abnormality occurs

- Contact Riken Keiki immediately.  
Visit our website for information on the nearest Riken Keiki office.  
Website: <https://www.rikenkeiki.co.jp/>

#### Sensor handling

- Never attempt to disassemble the electrochemical type sensor inside the product. Contact with the electrolyte inside the sensor may result in skin inflammation. Contact with eyes may result in blindness. Contact with clothing may result in discoloration or damage to the fabric.  
If contact occurs, rinse the area immediately with plenty of water.
- Do not use any gas other than nitrogen as the balance gas when adjusting the oxygen sensor.

#### Fresh air adjustment in surrounding atmosphere

- When fresh air adjustment is performed in the atmosphere, check the atmosphere for freshness before starting. The presence of interference gases will make it impossible to adjust the product correctly, resulting in the danger of erroneous detection when actual gas leaks occur.

#### Action when a gas alarm occurs

- A gas alarm indicates an extreme hazard. The user must take appropriate action after taking appropriate steps to ensure safety.

#### Battery level check

- Check battery levels before using the product. The battery may be depleted when the product is used for the first time or after extended periods without use. Charge the battery before use.
- If a low battery voltage alarm occurs, gas cannot be detected. If the alarm is issued during use, turn off the power and promptly charge the battery in a safe place.

#### Miscellaneous

- Do not dispose of the product into fire.
- Do not attempt to wash the product, either in a washing machine or an ultrasonic cleaning machine.
- Do not block the buzzer sound opening. Doing so will muffle or silence the audible warning.
- There is a danger that oxygen-deficient air or other gases may be discharged from enclosed locations. Never lean over or look inside openings.

## 2-3 Precautions



### CAUTION

- Do not use the product in locations where it may be exposed to oil or chemicals, etc.
  - Avoid using the product in locations where it may be splashed with oil, chemicals, or other liquids.
  - Do not place the product in locations where water or dirt accumulates. Placing the product in such locations may cause malfunction due to water or dirt ingress into the gas inlet or buzzer sound opening.
- The gas inlet and outlet are not waterproof. Take care to prevent water such as rainwater from entering these parts. Failure to do so may prevent gas detection.
- If the product has been exposed to water or dirt, remove any remaining water and dirt, and adjust as specified to confirm that it operates correctly.
- Do not use the product in locations outside the operating temperature range.
  - The operating temperature range for the product is as follows. Avoid using the product at temperatures outside the operating range.  
Continuous use environment: -20 °C - +50 °C  
Temporary use environment: -40 °C - +60 °C
  - Fully charge the battery before using the product on the lower temperature side of the temporary use environment temperature range (-40 °C - -20 °C).
  - Avoid using for extended periods in locations exposed to direct sunlight.
  - Avoid storing the product inside parked vehicles in hot weather.
- To prevent condensation within the product, adhere to the operating humidity range and avoid use under conditions in which condensation may form.  
Condensation forming inside the product may cause clogging or gas adsorption, which may prevent accurate gas detection. In addition to the usage environment, carefully monitor the temperature and humidity of the sampling point to prevent condensation forming inside the product.
- Do not use walkie-talkies near the product.
  - Radio waves from walkie-talkies or other radio wave transmitting devices near the product may affect readings. If walkie-talkies or other radio wave transmitting devices are used, these must be used away from the product where they do not affect operation.
  - Avoid using the product close to devices that emit strong electromagnetic radiation (e.g., high frequency or high voltage devices).
- Keep the product away from magnetic fields.
- Magnetic fields may cause the product to fail or malfunction. If the product does not operate correctly, use it away from magnetic fields.
- Verify that the operation status display is blinking before using the product.  
If the operation status display is not blinking, gas cannot be detected properly.

### Sensors

- Note that if combustible gas sensors are used in an environment where silicone compounds, halides, high-concentration sulfides, or high-concentration solvent gases are present, sensor life may be reduced, sensitivity to combustible gases may deteriorate, and accurate readings may not be obtained.  
If use in such environments is unavoidable, use for the shortest possible time and allow the product to suck in fresh air afterward. Confirm that the reading returns to normal and is stabilized.
- The combustible gas sensor (%LEL) in the product may cause readings to rise for gases like argon, carbon dioxide, and nitrogen.
- An oxygen concentration higher than a certain level is required in order for the combustible gas sensor (%LEL) in the product to correctly detect gases and display concentrations.
- Do not expose the product to sudden pressure fluctuations.  
Oxygen readings will vary temporarily, preventing accurate measurement.
- Do not use any gas other than nitrogen as the balance gas when adjusting the oxygen sensor.  
Otherwise, oxygen reading errors will increase, preventing accurate measurement.

**Be sure to perform regular maintenance.**

- The product must be maintained regularly to ensure safety. Continuing to use the product without maintaining it will result in sensor sensitivity variations, preventing accurate gas detection.

**Miscellaneous**

- Pressing buttons unnecessarily may change the settings, preventing alarms from activating correctly. Avoid performing any operations not described in this operating manual.
- Do not drop the product or subject it to impact. Doing so may degrade explosion-proof, waterproof, dustproof, and gas detection performance.
- An abnormality alarm may be triggered if the product is subjected to strong impact. If this occurs, turn the power off and then back on again, then perform a bump test to confirm that the product functions correctly before use.
- The impact resistance of the product is not a guarantee against damage or failure. Dropping the product may affect readings. We recommend performing inspection including gas adjustment if it has been dropped.
- Do not use the product while charging it.
- Do not prod the buzzer sound opening with sharp objects. Doing so may result in ingress of water or foreign matter, resulting in malfunctions or damage to the product.
- Do not block the buzzer sound opening with tape or other objects. This will prevent adjustment of the internal pressure of the product, which may result in malfunctions.
- Do not remove the panel sheet on the LCD display. Doing so will impair waterproof and dustproof performance.

**Usage**

- The operating time will be reduced due to battery performance in cold environments.
- The response of the LCD display may slow at low temperatures.
- Always perform fresh air adjustment under conditions of pressure, temperature, and humidity similar to those in the operating environment and in fresh air.
- Wait for the reading to stabilize before performing fresh air adjustment.
- If there is a temperature difference of 15 °C or more between the storage and usage locations, allow the product to stand and acclimatize for about 10 minutes in an environment similar to the usage location before turning on the power and performing fresh air adjustment in fresh air.
- When wiping the product clean, do not splash water on it or use organic solvents like alcohol and benzene. Doing so may discolor or damage the surfaces of the product.
- Even if you do not intend to use the product for extended periods, turn the power on at least once every six months to check that the pump operates normally and gas is sucked in (by running the product for approximately three minutes). Grease inside the pump motor may solidify and prevent operation if the product is not operated for extended periods.
- After a period of extended storage, be sure to perform gas adjustment before resuming use. For information on readjustment including gas adjustment, please contact Riken Keiki.

## 2-4 Safety information

Observe the following points to ensure performance as an explosion-proof product:

### Product overview

- The GX-Force can be equipped with up to three types of sensors to detect up to four different gas types.
- The GX-Force can be used to detect combustible gases (%LEL), oxygen (O<sub>2</sub>), hydrogen sulfide (H<sub>2</sub>S), and carbon monoxide (CO).
- Measurement results are displayed on the LCD. Gas alarms are indicated by LEDs and the buzzer based on the settings.

### Power source

- The GX-Force is powered by an internal rechargeable lithium ion battery. (The rechargeable battery cannot be replaced by the customer.)
- Charge the battery using the dedicated AC adapter, an IEC 60950 certified SELV power supply, or IEC 62368-1 certified ES1 power supply.
- Make sure that the maximum voltage from the charger does not exceed 6.0 V DC.

### <Japan EX specifications>

Explosion-proof construction:	Intrinsically safe explosion-proof construction, flame-proof enclosure
Explosion-proof class:	Ex da ia IIC Ta Ga
Ambient temperature*:	-20 °C - +60 °C
Ambient temperature (when charging):	+10 °C - +40 °C
Ratings:	Power supply: 3.6 V DC, 200 mA Battery pack (BP-Force) Battery charging contact allowable voltage: 6.0 V DC
Complies with the following guidelines:	JNIOOSH-TR-46-1:2020 JNIOOSH-TR-46-2:2018

\* Ambient temperature refers to the temperature range in which the explosion-proof performance can be maintained. It does not refer to the temperature range in which product performance is guaranteed. For information on the operating temperature range, refer to '10-1 Specifications list'.



## DANGER

- Charge the battery using the provided charger in a safe place.
- Charge the battery at ambient temperatures between +10 °C and +40 °C.



## WARNING

- Do not modify or alter the circuits or configuration.
- Do not disassemble or modify the product.
- In this product, only the NCR-6309 combustible gas sensor has a flame-proof enclosure.
- This product is an explosion-proof product. Do not disassemble or modify any parts other than those specified.  
(This includes the prohibition of repairs to flame-proof joints.)
- This product contains a sensor with a flame-proof enclosure. Explosion-proof performance may be impaired if not assembled as specified. When replacing the filter, use the dedicated components and mount correctly with the correct torque.
- If the housing becomes damaged, stop using the product and have it repaired.
- Do not use with the sensor exposed to ultraviolet light or insufficiently shaded.

- Do not charge in hazardous areas.
- Charge the battery using the dedicated AC adapter, an IEC 60950 certified SELV power supply, or IEC 62368-1 certified ES1 power supply.
- When measuring oxygen concentrations, use the product only to detect leaks of mixtures of air and combustible gas or toxic gas.
- When carrying and using the product in hazardous areas, the following general precautions must be observed to safeguard against static electricity hazards:
  - ① Wear anti-static clothing and conductive shoes (anti-static work shoes).
  - ② When using the product indoors, stand on a conductive work floor (with a leakage resistance of 10 MΩ or less).

### <ATEX/IECEX specifications>

<b>Explosion-proof construction</b>	Intrinsically safe explosion-proof construction, flame-proof enclosure	
<b>Explosion-proof class</b>	Ex da ia IIC T4 Ga	
		II 1 G Ex da ia IIC T4 Ga
<b>Ambient temperature</b>	-20 °C - +60 °C	
<b>Ambient temperature (when charging)</b>	+10 °C - +40 °C	
<b>Electrical specifications</b>	<ul style="list-style-type: none"> <li>• BP-Force is specified for the rechargeable lithium ion battery.</li> <li>• Uses one Panasonic NCR18650GA.</li> <li>• Charge the battery using the dedicated AC adapter, an IEC 60950 certified SELV power supply, or IEC 62368-1 certified ES1 power supply. Make sure that the maximum voltage from the charger does not exceed 6.0 V DC.</li> </ul>	
<b>Certificate numbers</b>	<ul style="list-style-type: none"> <li>• IECEX: IECEX DEK 24.0016X</li> <li>• ATEX: DEKRA 24ATEX0018X</li> </ul>	
<b>Applicable standards</b>	<ul style="list-style-type: none"> <li>• IEC 60079-0:2017</li> <li>• IEC 60079-1:2014-06</li> <li>• IEC 60079-11:2011</li> </ul>	<ul style="list-style-type: none"> <li>• EN IEC 60079-0:2018</li> <li>• EN 60079-1:2014</li> <li>• EN 60079-11:2012</li> </ul>



## WARNING

- Do not disassemble or modify the product.
- Only the NCR-6309 combustible gas sensor has a flame-proof construction in the product.
- The product is an explosion-proof device. Do not disassemble or modify components other than those stipulated.
- The product incorporates a flame-proof construction sensor. Explosion-proof performance may be impaired if it has not been assembled as specified. When replacing the filter, mount the specified parts using the correct torque.
- If the casing is damaged, stop using the product. Have it repaired before resuming use.
- Do not use the product with the sensors inadequately shielded or exposed to ultraviolet light.
- Do not charge in hazardous areas.
- Charge the battery using the dedicated AC adapter, an IEC 60950 certified SELV power supply, or IEC 62368-1 certified ES1 power supply.

**Product code**

INST. No. 00 0 000 0000 00  
                  A    B     C       D       E

A: Year of manufacture (0 - 9)

B: Month of manufacture (1 - 9 for Jan. - Sep.; XYZ for Oct., Nov., Dec.)

C: Manufacturing lot

D: Serial number

E: Factory code

**RIKEN KEIKI Co.,Ltd.**

2-7-6 Azusawa, Itabashi-ku, Tokyo, 174-8744, Japan

Phone: +81-3-3966-1113

Fax: +81-3-3558-9110

E-mail: [intdept@rikenkeiki.co.jp](mailto:intdept@rikenkeiki.co.jp)

Website: <https://www.rikenkeiki.co.jp>

---

**3**

---

# Product Configuration

## 3-1 Main unit and accessories

Open the box and packaging and inspect the product and accessories.  
If anything is missing, contact Riken Keiki.

### 3-1-1 Main unit

For detailed information on the names and functions of product parts and the LCD display, refer to '3-2 Part names and functions'.

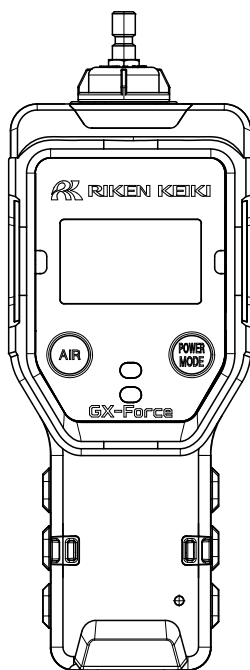

GX-Force main unit

## 3-1-2 Accessories

## &lt;Japan EX specifications&gt;

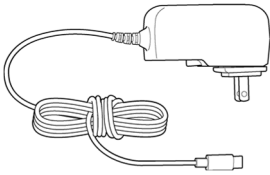
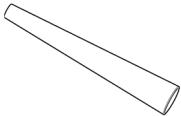
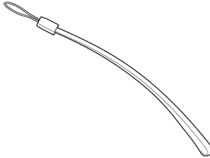
AC adapter ×1		Tapered nozzle ×1		
Hand strap ×1		Product warranty	Warranty	Operating Manual

## &lt; ATEX/IECEx specifications&gt;

Product warranty	Sensor warranty	Operating Manual
------------------	-----------------	------------------

## 3-1-3 Optional accessories

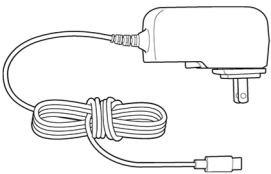
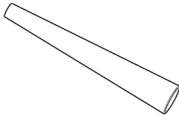
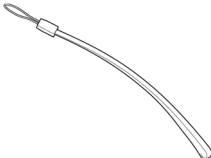
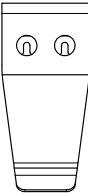
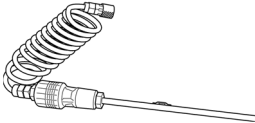
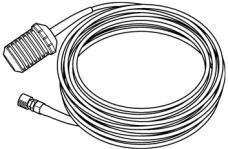
AC adapter ×1		
Tapered nozzle ×1		
Hand strap ×1		
Belt clip ×1		<ul style="list-style-type: none"> <li>Includes two screws for attachment to the rear of the main unit.</li> </ul>
Gas sampling rod Gas sampling tube ×1 each		<ul style="list-style-type: none"> <li>The gas sampling rod and gas sampling tube are used together.</li> </ul>
Float-type gas collector ×1		<ul style="list-style-type: none"> <li>The tube is about 8 m long.</li> </ul>

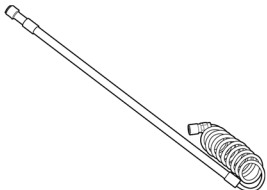
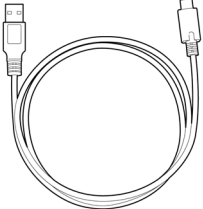
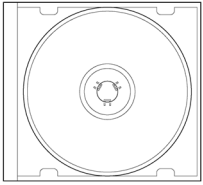

<p>Two-stage gas sampling rod ×1</p>	 A long, thin, cylindrical sampling rod with a coiled section at one end.	<ul style="list-style-type: none"><li>▪ The sampling rod length is as follows: Total length: Approx. 70 cm Reduced length: Approx. 40 cm</li></ul>
<p>USB cable Type-A - Type-C ×1</p>	 A coiled USB cable with a Type-A connector on one end and a Type-C connector on the other.	<ul style="list-style-type: none"><li>▪ For connecting to the PC when using the data logger management program</li><li>▪ The cable is 1 m long.</li></ul>
<p>Data logger management program CD- ROM (SW-GX-Force) ×1</p>	 A standard CD-ROM disc in its jewel case.	
<p>Various filters, etc.</p>		

## 3-2 Part names and functions

This section describes the names and functions of the various parts of the main unit and the LCD display.

### 3-2-1 Main unit

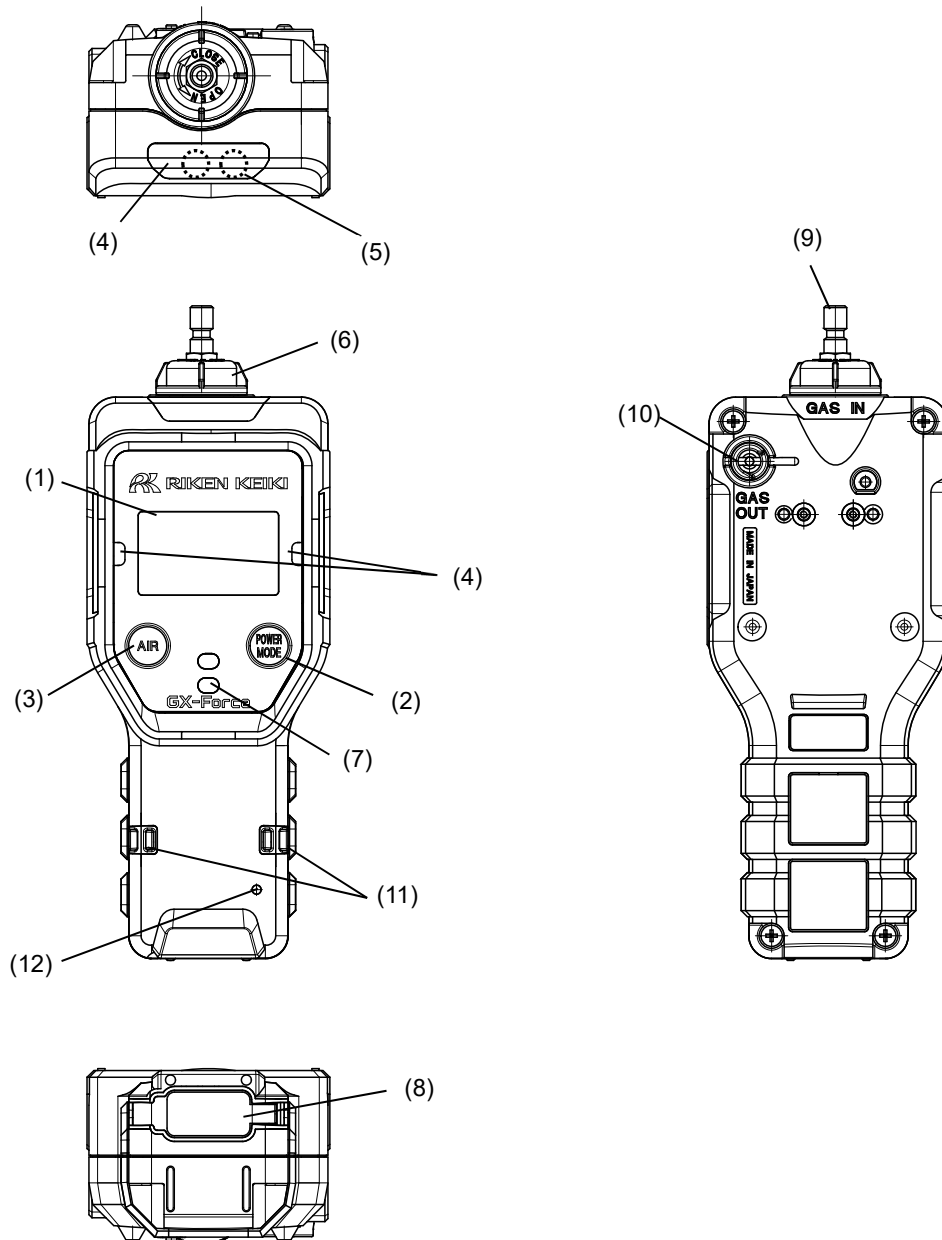

	Name	Main function
(1)	LCD display	Displays the gas concentration and other information.
(2)	POWER/MODE button	Turns the power on and off. Used to confirm settings when in display mode and user mode
(3)	AIR button	Performs fresh air adjustment in measurement mode. Used to select functions when in display mode and user mode

Name	Main function
(4) Alarm LED arrays	Flashes in red when an alarm occurs. The LEDs on the left and right also flash red if measurement is not currently underway.
(5) Light	Lights up when the light is turned on.
(6) Filter case	Contains a dust filter. (Do not open except when inspecting or replacing the filter.)
(7) Buzzer sound opening	Emits operating and alarm sounds. (Do not block.)
(8) USB protective cover	Detach the cover to connect the AC adapter when charging. Connect a USB cable to connect to a PC.
(9) Gas inlet	Connector for attaching tapered nozzle
(10) Gas outlet	Outlet for gas drawn in (Do not block.)
(11) Strap holes (two locations)	Holes for attaching the hand strap. There are two holes on each side (left and right).
(12) Charging indicator lamp	Lights up in green when the charger is connected, and lights up in orange when charging starts. Lights up in green once charging is completed.



## CAUTION

- Do not prod the buzzer sound opening with sharp objects. Doing so may result in ingress of water or foreign matter, resulting in malfunctions or damage to the product.
- Do not remove the panel sheet on the LCD display. Doing so will impair waterproof and dustproof performance.
- Do not block the buzzer sound opening with tape or other objects. This will prevent adjustment of the internal pressure of the product, which may result in malfunctions.
- Do not block the gas outlet or subject it to force.
- Before using the gas sampling rod and various gas sampling tubes, check to confirm that the tubes are free of damage and provide appropriate flow rates.
- Use of the gas sampling rod and various gas sampling tubes will create a response delay of up to three seconds per meter of flow length.

## NOTE

- ▶ In this operating manual, the POWER/MODE button is described as follows:
  - When turning power on/off: POWER button
  - When confirming settings: MODE button

3-2-2 LCD display

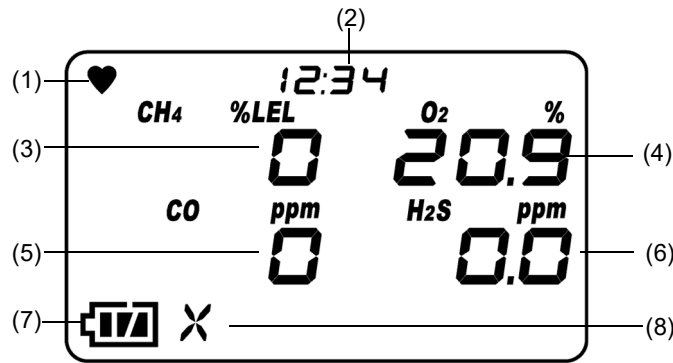

Name	Main function
(1) Operating status icon	Indicates the product operating status. Blinks when normal.
(2) Clock display	Displays the time.
(3) Combustible gas concentration	Displays gas concentrations. The concentration reading is updated every five seconds for combustible gases. The concentration reading is updated every second for gases other than combustible gases.
(4) Oxygen concentration	
(5) Carbon monoxide concentration	
(6) Hydrogen sulfide concentration	
(7) Battery level icon	Indicates battery levels. See NOTE below for a guide to battery level indications.
(8) Pump operating status icon	Indicates suction status. Rotates when normal.

NOTE

- ▶ Approximate battery levels are indicated as follows:
  - ☐: Sufficient
  - ▒: Low
  - ⬜: Needs charging
 The battery level icon will blink if the battery level drops even further.
- ▶ If the bump test expiration display setting is enabled, [✓] is displayed in the upper left of the LCD until the bump test expiration date. For information on the bump test expiration display setting, refer to '6-4-4 Bump test setting'.
- ▶ [M] is displayed in the upper left of the LCD when user mode is selected.

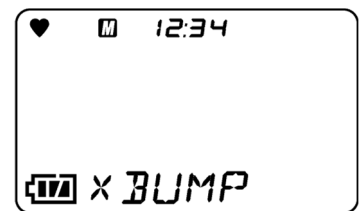
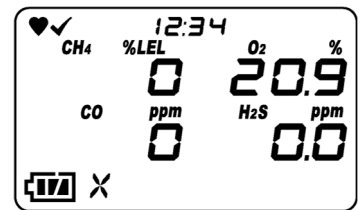

## 4

# Alarm Activation

## 4-1 Gas alarm types

A gas alarm is triggered if the concentration of the detected gas reaches or exceeds the alarm setpoints shown in the following table. (Self-latching)

Gas alarm types include the first alarm (WARNING), second alarm (ALARM), third alarm (ALARM H), TWA alarm, STEL alarm, OVER alarm (over scale), and M OVER alarm (minus sensor failure).

Gas alarms are prioritized as follows:

First alarm < second alarm < third alarm < M OVER alarm < OVER alarm < TWA alarm < STEL alarm

## 4-2 Gas alarm setpoints

The default settings for gas alarm setpoints are as shown in the following table:

<Default settings>

Item	Target gas	Combustible gas	O <sub>2</sub>	CO	H <sub>2</sub> S
		HC or CH <sub>4</sub>			
Display range (Resolution)		0 - 100 %LEL	0.0 - 40.0 %	0 - 2,000 ppm	0.0 - 200.0 ppm
Detection range (Japan EX specifications)		0 - 100 %LEL	0.0 - 25.0 %	0 - 500 ppm	0.0 - 30.0 ppm
Minimum resolution		1 %LEL	0.1 %	1 ppm	0.1 ppm
Alarm setpoints (Japan EX specifications)		1st alarm: 10 %LEL 2nd alarm: 50 %LEL 3rd alarm: 50 %LEL OVER alarm: 100 %LEL MOVER alarm: -10 %LEL	L: 19.5 % LL: 18.0 % H: 25.0 % OVER alarm: 40.0 % MOVER alarm: -1.0 %	1st alarm: 25 ppm 2nd alarm: 50 ppm 3rd alarm: 50 ppm TWA alarm: 25 ppm STEL alarm: 200 ppm OVER alarm: 2,000 ppm MOVER alarm: -50 ppm	1st alarm: 1.0 ppm 2nd alarm: 10.0 ppm 3rd alarm: 10.0 ppm TWA alarm: 1.0 ppm STEL alarm: 5.0 ppm OVER alarm: 200.0 ppm MOVER alarm: -10.0 ppm
Alarm setpoints (ATEX/IECEx specifications)		1st alarm: 10 %LEL 2nd alarm: 25 %LEL 3rd alarm: 50 %LEL OVER alarm: 100 %LEL MOVER alarm: -10 %LEL	L: 19.5 % LL: 18.0 % H: 23.5 % OVER alarm: 40.0 % MOVER alarm: -1.0 %	1st alarm: 25 ppm 2nd alarm: 50 ppm 3rd alarm: 1,200 ppm TWA alarm: 25 ppm STEL alarm: 200 ppm OVER alarm: 2,000 ppm MOVER alarm: -50 ppm	1st alarm: 5.0 ppm 2nd alarm: 30.0 ppm 3rd alarm: 100.0 ppm TWA alarm: 1.0 ppm STEL alarm: 5.0 ppm OVER alarm: 200.0 ppm MOVER alarm: -10.0 ppm

**NOTE**

- ▶ The default settings for gas alarm setpoints are as shown in the table on the previous page.
- ▶ The alarm setpoints indicated for the first alarm (WARNING), second alarm (ALARM), third alarm (ALARM H), TWA and STEL alarm in the table on the previous page can be changed. For information on how to change the alarm setpoints, refer to '6-4-5 Alarm setpoint setting'.
- ▶ The M OVER alarm (negative sensor failure) occurs when the zero point drifts to the negative side.

**4-3 Gas alarm patterns**

**<Gas alarm buzzer sounding and lamp flashing patterns>**

When a gas alarm occurs, the user is notified by the buzzer sounding, the alarm LED array flashing, and vibration.

The individual operations are as follows:

Alarm type	First alarm	Second alarm	Third alarm	TWA alarm	STEL alarm	OVER alarm	M OVER alarm
<b>Buzzer sounding</b>	Repeated alternating loud and soft beeps						Repeated intermittent beeps
	Approx. 1-second interval "Beep, beep"	Approx. 0.5-second interval "Beep, beep, beep, beep"	Approx. 0.5-second interval "Beep, beep, beep, beep"	Approx. 1-second interval "Beep, beep"	Approx. 1-second interval "Beep, beep"	Approx. 0.5-second interval "Beep, beep, beep, beep"	Approx. 1-second interval "Beep, beep"
<b>Alarm LED array flashing</b>	Repeated flashing						
	Approx. 1-second interval	Approx. 0.5-second interval	Approx. 0.5-second interval	Approx. 1-second interval	Approx. 1-second interval	Approx. 0.5-second interval	Approx. 1-second interval
<b>Vibration</b>	Vibration when alarm occurs						None

For gases other than oxygen: Alarm pattern (H-HH-HHH)

For oxygen: Alarm pattern (L-LL-H)

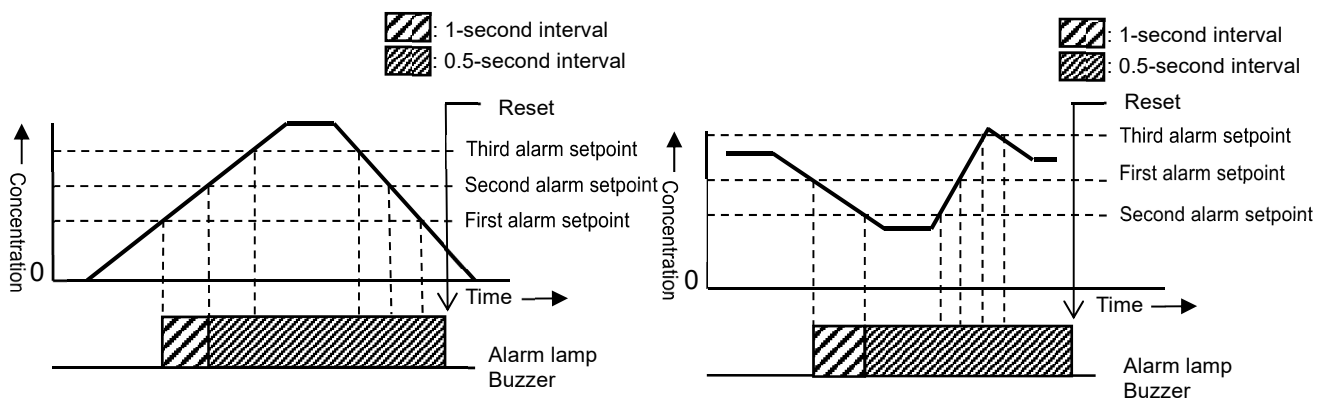

**NOTE**

- ▶ If the alarm silence function is enabled (the default setting), you can stop only the buzzer sound by pressing the MODE button when a gas alarm is triggered. The buzzer will sound once again if a new gas alarm is triggered after you stop the first buzzer. This function can be enabled/disabled in the optional data logger management program (SW-GX-Force).
- ▶ If the alarm silence function is disabled, the buzzer sound will not stop when a gas alarm is triggered.

### <Gas alarm display>

If a gas alarm occurs, the alarm type is indicated at the bottom of the screen and the corresponding gas concentration, gas name, and unit displays blink. If the detection range is exceeded (over scale), [OVER] appears at the bottom of the screen and [∩∩∩] blinks in the gas concentration display area.

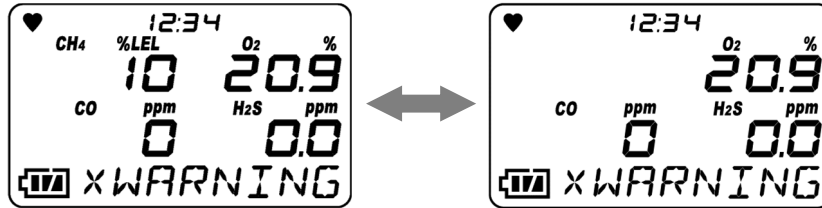

Display example: Methane (CH<sub>4</sub>) concentration: 10 %LEL first alarm triggered

Alarm type	First alarm	Second alarm	Third alarm	TWA alarm	STEL alarm	OVER alarm	M OVER alarm
LCD Display	Gas concentration blinks.	Gas concentration blinks.	Gas concentration blinks.	Gas concentration blinks.	Gas concentration blinks.	[∩∩∩] blinks in gas concentration value display area.	[UUU] blinks in gas concentration value display area.
	Screen display: [WARNING]	Screen display: [ALARM]	Screen display: [ALARM H]	Screen display: [TWA]	Screen display: [STEL]	Screen display: [OVER]	Screen display: [M OVER]

## WARNING

- A gas alarm indicates the presence of extreme danger. The user must take appropriate action after taking appropriate steps to ensure safety.

## NOTE

- ▶ The alarm pattern can be checked using an alarm test in display mode. Note, however, that the gas concentration value will not blink in alarm tests.

## 4-4 Fault alarm patterns

A fault alarm is triggered if an abnormality is detected in the product. (Self-latching)

Fault alarm types include system abnormality, clock abnormality, battery voltage abnormality, sensor abnormality, pump abnormality, and low flow rate abnormality.

If a fault alarm occurs, the user is notified by the buzzer sounding and alarm LED array flashing.

- Buzzer sounding: Repeated intermittent beeps at about 1-second intervals (“Beep-beep, beep-beep”)
- Alarm LED array flashing: Repeated flashing at about 1-second intervals

The following shows typical fault alarm displays:

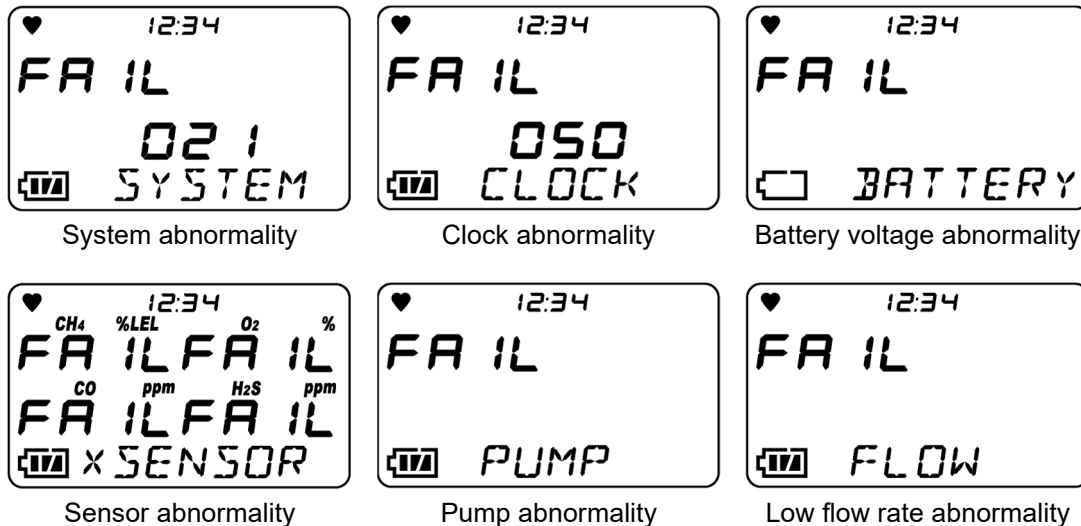

If a fault alarm occurs, determine the cause and take appropriate action.

If the problem lies with the product and the fault occurs repeatedly, contact Riken Keiki immediately.

### NOTE

- For more information on malfunctions (error messages), refer to '9 Troubleshooting'.



---

## 5

---

# Usage Instructions

## 5-1 Usage note

The operating precautions apply to both first-time users and those who have previously used the product. Ignoring these precautions may damage the product and result in inaccurate gas detection.

## 5-2 Preparations for startup

Check the following before starting gas detection:

- The type and specifications of the particular product being used
- Gas alarm setpoints
- Confirm that the filters are present inside the product and are not contaminated or clogged.
- Confirm that the battery level is sufficient.
- Confirm that the pump is operating normally. (Check that a low flow rate alarm occurs when the gas inlet is blocked with a finger.)

---

### NOTE

- ▶ For information on the product type and specifications, refer to '1-3 Checking the detection target gases and product type' and '1-5 Checking standards and explosion-proof specifications'.
- ▶ For information on the product gas alarm setpoint default settings, refer to '4-2 Gas alarm setpoints'.
- ▶ For information on the low flow rate alarm and how to reset it, refer to '4-4 Fault alarm patterns'.
- ▶ If the settings for the product have been altered from an external device, be sure to confirm that the settings have been altered correctly.
- ▶ Protective film is attached to the LCD display on the product to protect it against scratching during shipping.

Be sure to peel off this protective film before using the product. Explosion-proofing cannot be guaranteed if the protective film is left attached.

---

### 5-2-1 Charging the lithium ion battery

Before using the product for the first time or if battery level of the lithium ion battery is low, charge as described below.

#### **DANGER**

- Charge in a location free of hazards.
- Charge the battery using the dedicated AC adapter, an IEC 60950 certified SELV power supply, or IEC 62368-1 certified ES1 power supply.
- Charge the battery at ambient temperatures between +10 °C and +40 °C.

#### **CAUTION**

- Be sure to turn off the power for the product before charging the battery.
- Do not use the product while charging the battery. The measurements obtained will not be correct. Additionally, doing so will degrade the battery more quickly and reduce battery life.
- The charger is neither waterproof nor dustproof. Do not charge the battery while the product is wet.
- The charger is not explosion-proof.
- The main unit may get hot during charging. This does not indicate an abnormality.
- The main unit will grow warmer while charging. Once charging is completed, wait at least 10 minutes before use. Using the product while it is still hot may result in incorrect measurements.
- When fully charged, the battery cannot be charged.
- Always unplug the charger from the outlet when not in use.
- Using a charger other than the dedicated charger may result in slow charging or other charging problems.

#### <Charging the lithium ion battery>

- 1 Open the USB protective cover on the product.
- 2 Insert the charger plug into the USB Type-C connector of the main unit.

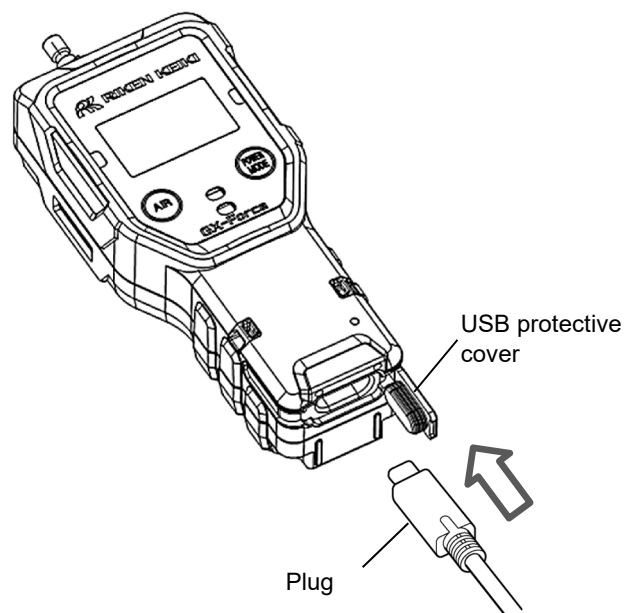

**3 Plug the charger into the outlet.**

When the charger is connected, the charging indicator lamp lights up in green. When charging starts, the lamp lights up in orange. (Full charge requires about 10 hours at maximum.)

Once charging is completed, the charging indicator lamp lights up in green.

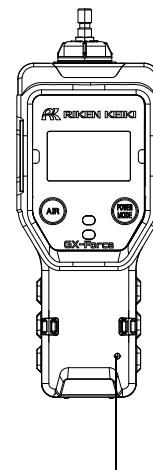
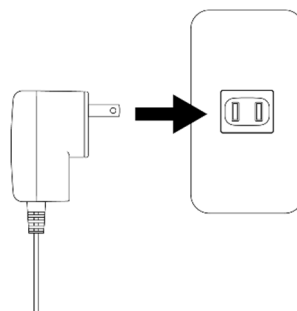

Charging indicator lamp

**4 When charging is complete, unplug the charger from the outlet and close the USB protective cover.**

Press the USB protective cover securely into place.

## 5-3 Startup procedure

When the power is turned on, various settings including the date and time and alarm setpoints are displayed, and then the measurement mode screen is displayed.

### 5-3-1 Turning on the power

- 1 Hold down the **POWER** button (for at least three seconds) until the buzzer blips.

The power turns on.

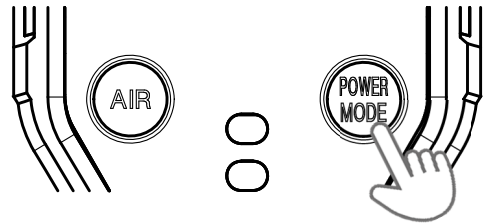

The entire LCD display lights up.

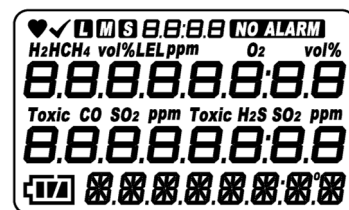

#### NOTE

- ▶ When the power is turned on, the LCD, light, LEDs, and buzzer start to operate, and the product vibrates. Before using the product, check that these operations function correctly.

**5-3-2 Screen transition from powering on to measurement mode**

When the power is turned on, the LCD display changes automatically as shown below, then the product switches to measurement mode.

<Display examples: Default settings> (Approx. 40 seconds)

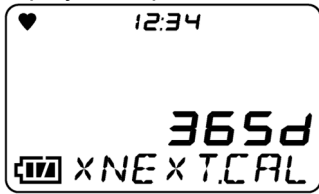

Maintenance notification display screen  
\* Displayed with Japan EX specifications only

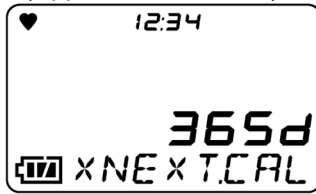

Gas adjustment expiration display screen  
\* Displayed with ATEX/IECEX specifications only

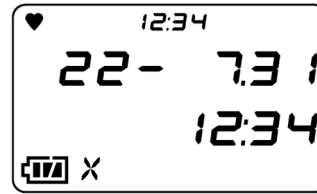

Date and time display

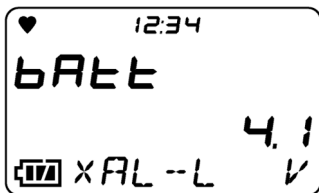

Battery level/alarm pattern display

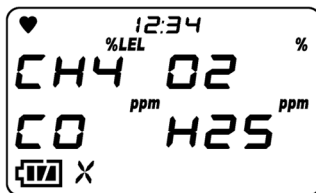

Detection target gas display

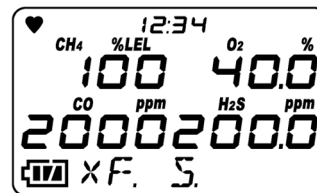

Full scale display

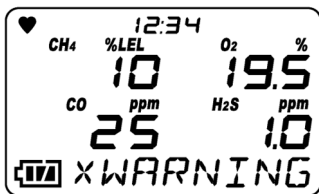

First alarm setpoint display

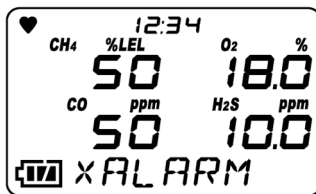

Second alarm setpoint display

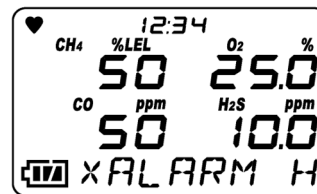

Third alarm setpoint display

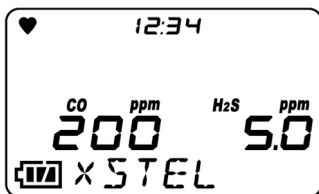

STEL alarm setpoint display

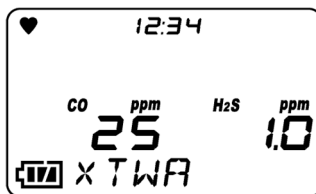

TWA alarm setpoint display

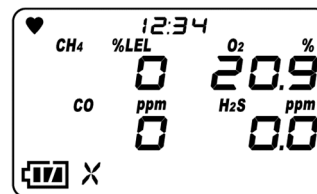

Measurement mode  
The buzzer blips twice and the product switches to measurement mode.

**CAUTION**

- With ATEX/IECEx specifications, notification is given when the power is turned on if the set adjustment expiration date has passed. The behavior differs depending on the settings. For information on the AUTO adjustment cylinder settings, refer to '7-2 Gas adjustment'. If you perform adjustment, perform after waiting at least 45 seconds after the power has been turned on.
  - [CONFIRM]: Triggers a fault alarm. Press the MODE button to proceed to AUTO adjustment cylinder settings.
  - [CANT.USE]: Triggers a fault alarm. Press the MODE button or wait six seconds to automatically proceed to AUTO adjustment cylinder settings.
  - [NONE]: Notifies that adjustment has expired. Press the MODE button to proceed to AUTO adjustment cylinder settings. If no button is pressed for six seconds, the product automatically switches to measurement mode.
- If the set bump test expiration date has passed, notification is given when the power is turned on. The behavior differs depending on the settings. For information on the bump test cylinder settings, refer to '7-3 Bump test'.
  - [CONFIRM]: Triggers a fault alarm. Press the MODE button to proceed to bump test cylinder settings.
  - [CANT.USE]: Triggers a fault alarm. Press the MODE button or wait six seconds to automatically proceed to bump test cylinder settings.
  - [NONE]: Notifies that the bump test has expired. Press the MODE button to proceed to bump test cylinder settings. If no button is pressed for six seconds, the product automatically switches to measurement mode.

- With models that detect combustible gases, the screen shown on the right may be displayed with the buzzer sounding and LED flashing after the battery level and alarm pattern are displayed. If this screen is displayed, some combustible gases cannot be converted using the combustible gas conversion function. For information on the types of gases that cannot be converted, refer to '6-2-3 Combustible gas conversion setting'.

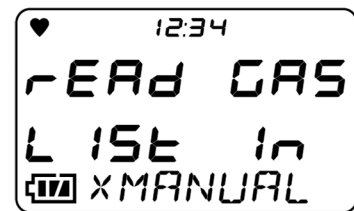

If the screen shown on the right appears, the alarm can be temporarily reset by pressing the MODE button (or after five seconds if no buttons are pressed).

Note that the screen shown on the right appears when the combustible gas sensor is placed under the poisoning effects of silicone compounds or halides. If the screen shown on the right is displayed, the conversion function can be used only for those gas types marked "O" in the "Conversion when conversion is restricted" column. To continue to use the conversion function for gas types marked "x", contact Riken Keiki.

- If a gas that cannot be converted has been set, the setting will automatically return to the calibration gas.
- If any abnormality is detected in the sensor, [FAIL] appears in place of the measured value just before the product switches to measurement mode, and a sensor abnormality alarm is triggered. If this occurs, press the MODE button to temporarily reset the sensor abnormality alarm. However, the alarm cannot be reset if there is an abnormality in all of the sensors. After the alarm is reset, [- - -] appears in the concentration display area of the gas for which the sensor abnormality occurred, and detection will not be possible for that gas type. Contact Riken Keiki immediately.
- After startup, perform fresh air adjustment before starting gas detection. (Refer to '5-4 Fresh air adjustment'.)

---

**NOTE**

- ▶ If an abnormality arises in the built-in clock, a fault alarm ([FAIL CLOCK]) may be triggered. If this occurs, press the MODE button. The fault alarm will be temporarily reset, and measurement will be started with the clock time remaining incorrect.

**Lunch break**

When the lunch break setting is enabled, the screen is displayed with a five-second countdown to allow the user to confirm whether to retain the TWA and PEAK values from the last time the power was turned off and continue measurement or to reset the values when the power is turned on. Pressing the MODE button retains the measurement data. Pressing the AIR button resets the measurement data. If no button is pressed for five seconds, the measurement data is automatically retained.

**Bump test expiration date**

When the bump test expiration display setting is enabled, the number of days remaining after the last bump test date until a specified setting date is displayed when the power is turned on. For information on the bump test expiration setting, refer to '6-4-4 Bump test setting'.

**Maintenance notification display**

<Japan EX specifications>

The number of days up to one year (365 days) remaining after the last adjustment date is displayed. The buzzer sounds if more than one year has elapsed since the last adjustment date. To cancel the buzzer, press the AIR button.

<ATEX/IECEX specifications>

The number of days remaining after the last adjustment date until a specified setting date is displayed. For information on the adjustment expiration setting, refer to '6-4-3 Adjustment expiration setting'.

**Date and time**

Displays the date and time. You can set the date and time following the instructions in '6-4-13 Date and time setting'.

If a USB connection is detected while the time and date is displayed, the product switches to communication mode. The product also switches to communication mode if you press the AIR and MODE buttons at the same time.

**Battery level/alarm pattern**

The battery level (voltage) and alarm pattern setting ([AL-L] (self-latching)) is displayed on the screen.

If a USB connection is detected while the battery level and alarm pattern is displayed, the product switches to communication mode. The product also switches to communication mode if you press the AIR and MODE buttons at the same time.

**Detection target gas name**

Displays the detection target gas. The gas currently being converted is displayed at the bottom of the screen if a combustible gas is being converted.

**Full scale**

Displays the full-scale value of the detection target gas. IEC or ISO is displayed in the full-scale display area if IEC or ISO LEL values are set.

**First alarm setpoint**

Displays the first alarm setpoint for the detection target gas.

**Second alarm setpoint**

Displays the second alarm setpoint for the detection target gas.

**Third alarm setpoint**

Displays the third alarm setpoint for the detection target gas.

**STEL alarm setpoint** ([TWA] and [STEL] are displayed only on models that detect gases other than combustible gases and oxygen.)

Displays the STEL alarm setpoint for the detection target gas. The STEL value refers to the concentration of a toxic substance that does not adversely affect the user's health with 15-minute continuous exposure, provided that daily exposures do not exceed the TWA value.

Not displayed on models where CO and H<sub>2</sub>S are not included in the detection target gases.

**TWA alarm setpoint** ([TWA] and [STEL] are displayed only on models that detect gases other than combustible gases and oxygen.)

Displays the TWA alarm setpoint for the detection target gas. The TWA value refers to the time-weighted average concentration limit of a toxic substance for a normal 8-hour workday and a 40-hour workweek to which almost all users may be repeatedly exposed without adverse health effect.

## 5-4 Fresh air adjustment

Fresh air adjustment refers to zero adjustment required to ensure accurate measurement of gas concentrations.

### WARNING

- When fresh air adjustment is performed in the atmosphere, check the atmosphere for freshness before starting. The presence of interference gases will make it impossible to perform fresh air adjustment correctly and potentially result in hazardous conditions in the event of actual gas leaks.

### CAUTION

- After startup, perform fresh air adjustment before starting gas detection.
- Always perform fresh air adjustment under conditions of pressure, temperature, and humidity similar to those in the operating environment and in fresh air.
- Wait for the reading to stabilize before performing fresh air adjustment.
- If there is a temperature difference of 15 °C or more between the storage and usage locations, allow the product to stand and acclimatize for about 10 minutes in an environment similar to the usage location before turning on the power and performing fresh air adjustment in fresh air.

**1 Hold down the AIR button in measurement mode.**

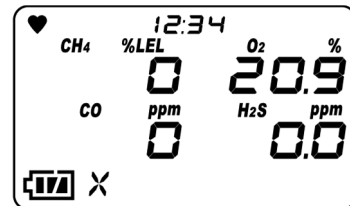

The fresh air adjustment screen is displayed. Keep the AIR button pressed for as long as the screen shown on the right is displayed. Fresh air adjustment will not be performed if you release the button before the screen is displayed or while it is displayed.

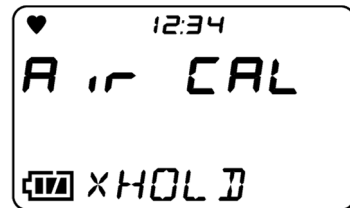

**2 Release the AIR button once the screen shown on the right appears.**



The product automatically returns to measurement mode once fresh air adjustment has been successfully completed.

### NOTE

- ▶ If fresh air adjustment fails, [FAIL] appears in the concentration display area for the corresponding sensor. Press the MODE button to reset the fault alarm (adjustment failure). Resetting the alarm displays the value before adjustment. For more information on resetting this fault, refer to '9 Troubleshooting'.



## 5-5 Gas detection



### **DANGER**

- If measuring inside manholes or enclosed spaces, never lean over or look into the manhole or enclosed space. There is a danger that oxygen-deficient air or other gases may be discharged from such locations.



### **WARNING**

- When fresh air adjustment is performed in the atmosphere, check the atmosphere for freshness before starting. The presence of interference gases will make it impossible to perform adjustment correctly and potentially result in hazardous conditions in the event of actual gas leaks.
- A gas alarm indicates the presence of extreme danger. The user must take appropriate action based on the situation.
- If the battery voltage drops, gas cannot be detected. If a low battery voltage alarm occurs during use, turn off the power and promptly charge the battery in a safe place.
- Do not block the buzzer sound opening. Doing so will muffle or silence the audible warning.



### **CAUTION**

- Check the settings before starting gas detection.
- Readings close to the zero level are subject to processing to minimize fluctuations.

5-5-1 Basic operating flow

Turn on the power to proceed to the measurement mode screen.

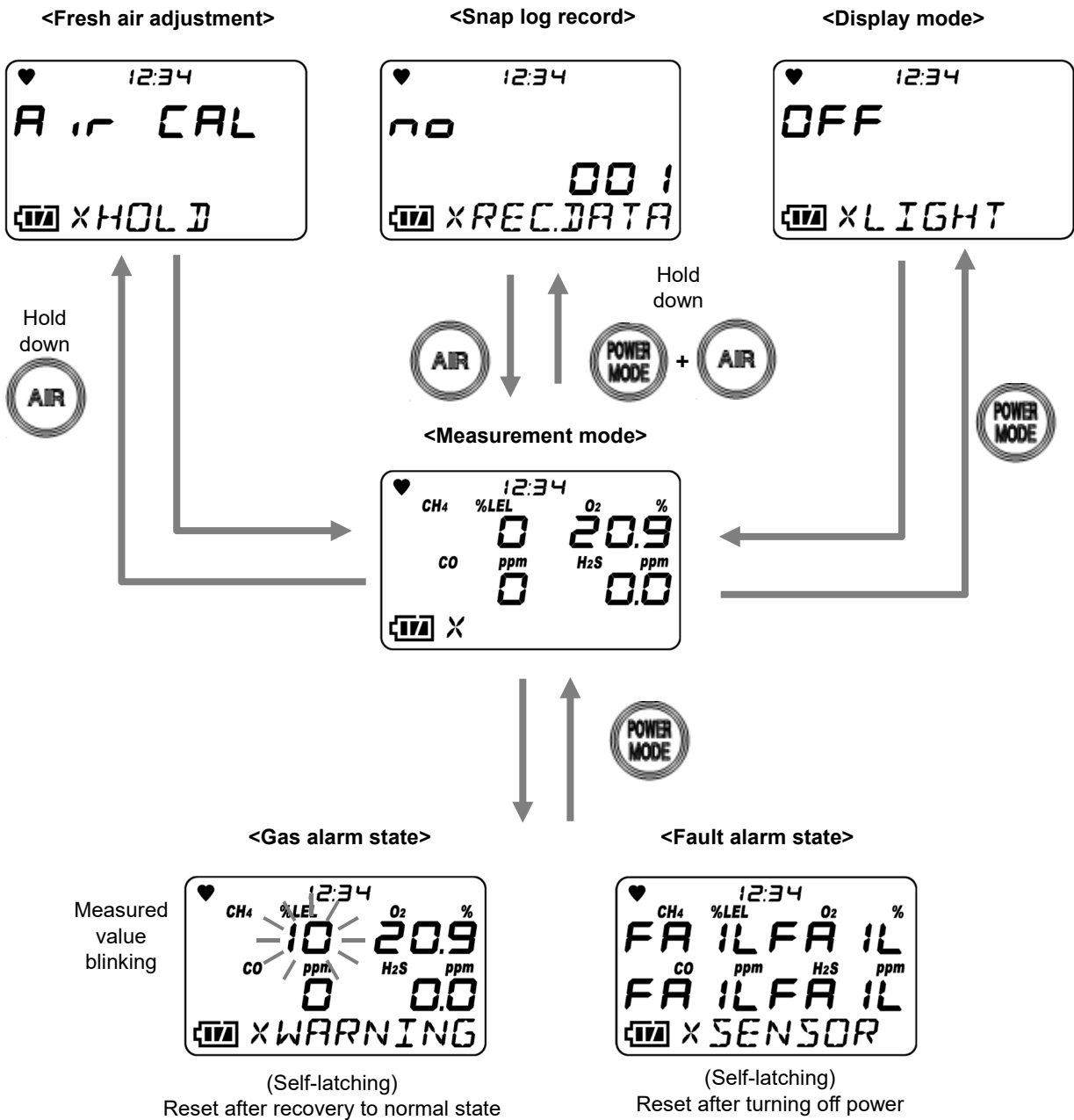

5-5-2 Measurement mode

In measurement mode, read the values on the LCD display.

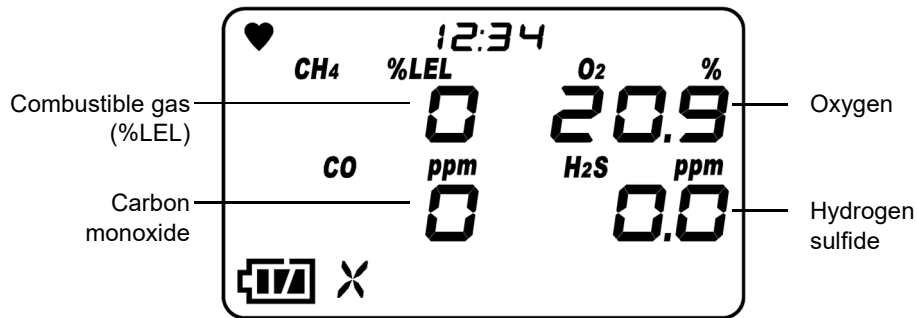

Display example

 CAUTION

- Note that if combustible gas sensors are used in an environment where silicone compounds, halides, high-concentration sulfides, or high-concentration solvent gases are present, sensor life may be reduced, sensitivity to combustible gases may deteriorate, and accurate readings may not be obtained. If use in such environments is unavoidable, use for the shortest possible time. Allow the product to stand in fresh air after use, and confirm that the reading returns to normal and is stabilized.
- An oxygen concentration higher than a certain level is required in order for the combustible gas sensor (%LEL) in the product to correctly detect gases and display concentrations.
- Do not expose the product to sudden pressure fluctuations. Oxygen readings will vary temporarily, preventing accurate measurement.
- Do not use any gas other than nitrogen as the balance gas when adjusting the oxygen sensor. Otherwise, oxygen reading errors will increase, preventing accurate measurement.
- If the product is exposed to highly adsorptive gas, allow the product to suck in fresh air, and confirm that the reading returns to zero before use.
- The hydrogen sulfide (H<sub>2</sub>S) sensor may exhibit temporary fluctuations if exposed to sudden temperature and humidity variations. Allow the product to stand and acclimatize in the ambient atmosphere.
- The carbon monoxide sensor (ESR-A1CP) includes a correction function to reduce interference due to hydrogen. This function works for hydrogen concentrations up to 2,000 ppm. However, if used in an environment exceeding 40°C for more than 15 minutes, it may be affected by hydrogen interference and may indicate a higher carbon monoxide concentration than actual.
- If the carbon monoxide sensor (ESR-A1CP) detects hydrogen at a concentration of 2,000 ppm or higher, [H<sub>2</sub>] and [rich] are displayed alternately in the concentration display area. While measurement can continue, errors will arise with carbon monoxide concentration readings due to the significant effects of hydrogen interference.

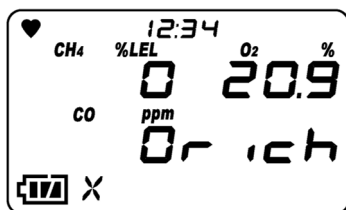

Concentration display: [rich]

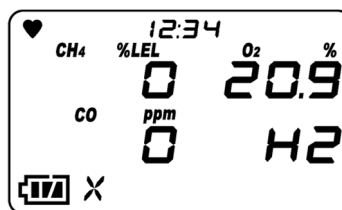

Concentration display: [H<sub>2</sub>]

**NOTE**

- ▶ The gas currently being converted is displayed at the bottom of the screen if a combustible gas is being converted.
- ▶ The operating time will be reduced due to battery performance in cold environments.
- ▶ The response of the LCD display may slow at low temperatures.
- ▶ If the product is exposed to a combustible gas at concentrations of 100 %LEL or above, some adsorbed gas may remain in the filter. After drawing in high-concentration combustible gas, always allow the product to suck in fresh air. Perform air cleaning until the reading returns to around zero to remove any adsorbed gas. Performing fresh air adjustment before a complete cleaning may prevent accurate adjustment, with potential adverse effects on measurement. Locking over will occur if 100 %LEL is detected. This will not be reset until either the oxygen concentration decreases or you press the MODE button.
- ▶ The zero point for carbon monoxide (CO) and hydrogen sulfide (H<sub>2</sub>S) sensors may fluctuate at low or high temperatures. If this occurs, perform fresh air adjustment in the ambient atmosphere.
  
- ▶ Sensitivity may be reduced temporarily if the carbon monoxide sensor comes into contact with gas at concentrations exceeding its measurement range. If the sensor has come into contact with high-concentration gas, be sure to allow it to suck in fresh air and perform air cleaning.
- ▶ Sensitivity may be reduced temporarily if the hydrogen sulfide (H<sub>2</sub>S) sensor comes into contact with gas at concentrations exceeding its measurement range. If the sensor has come into contact with high-concentration gas, be sure to allow it to suck in fresh air and perform air cleaning.
- ▶ A temperature range error will occur if measurement outside the operating temperature range continues for more than 20 minutes. When a temperature range error occurs, either leave the product for five minutes or longer in the operating temperature range, or turn off the power of the main unit.

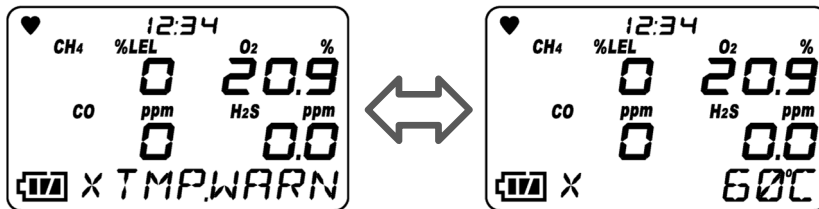

### 5-5-3 Snap log recording

Instantaneous concentration values can be recorded for user-specified gases while measurement is in progress.

Up to 256 items can be recorded in the snap log. When the maximum number of items is reached, the oldest data is overwritten by new data.

**1 Hold down the AIR button and MODE button at the same time in measurement mode.**

The memory number, station ID, date and time, and instantaneous value are displayed in sequence.

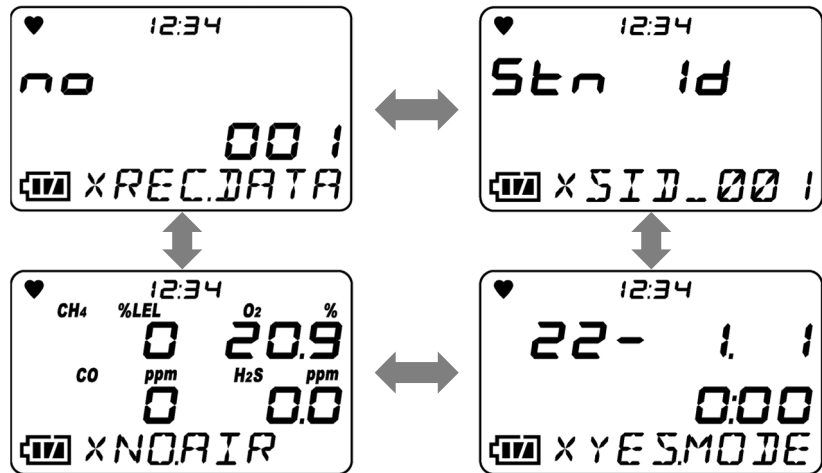

**2 Press the MODE button.**

The instantaneous gas concentration is stored together with the date and time at which the MODE button was pressed.

[SAVED] is displayed and the display returns to the screen in Step 1.

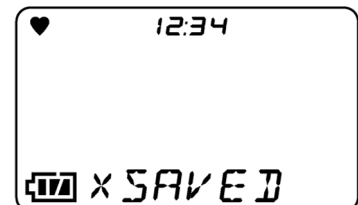

#### NOTE

- ▶ To continue snap log recording, repeat the procedure in Step 2.
- ▶ To stop or exit snap log recording, press the AIR button in Step 2. Pressing the AIR button returns the product to measurement mode.
- ▶ The recorded data can be checked on the REC.DATA screen in display mode. (Refer to '6-2-6 Snap log data display'.)

## 5-6 Turning off the power



### CAUTION

- If the concentration display does not return to zero (or 20.9 % for the oxygen concentration display) after measurement is completed, allow the product to suck in fresh air until the display returns to zero before turning off the power.

#### 1 Hold down the POWER button.

To turn off the power, wait for the display to return to zero (or 20.9% for the oxygen concentration display) in a location free of hazardous gases, then hold down the POWER button.

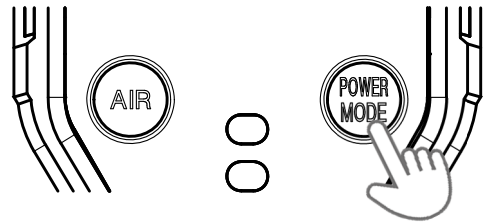

The buzzer blips three times and [TURN OFF] appears on the display before the power turns off.

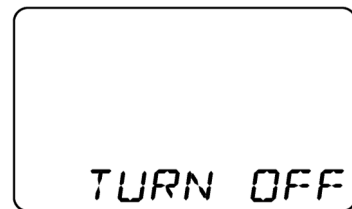

Power-off display

### NOTE

- ▶ When turning off the power, hold down the button until the display turns off.
- ▶ If the display has not returned to zero when you turn off the power, purging will be performed for up to 30 seconds to clean the product interior.  
The screen as shown on the right is displayed while purging is in progress.

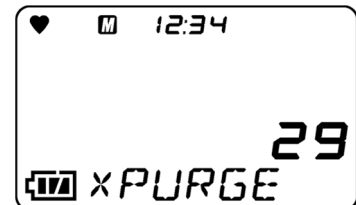

### CAUTION

- If the product has become dirty, wipe it with a rag or cloth soaked in water and firmly wrung out.
- When wiping the product clean, do not use organic solvents like alcohol or benzene or commercially available cleaners.

## 6

# Setting Procedure

## 6-1 Display mode

Display mode lets users review and change various display settings and perform other operations. Changed settings are saved.

### 6-1-1 Switching to display mode

- 1 Press the MODE button in measurement mode.

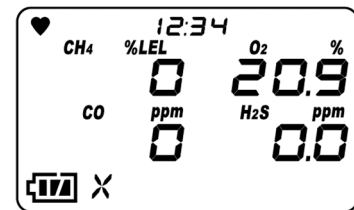

Pressing the MODE button displays the various setting item screens in sequence.

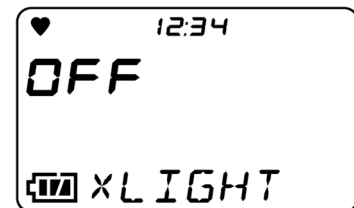



- 2 Once the settings are complete, press the MODE button in display mode several times.

The product returns to measurement mode.

### NOTE

- ▶ If no button is pressed for about 20 seconds, the product will return to measurement mode.
- ▶ To test the alarm, press the AIR button and MODE button at the same time while an alarm setpoint is displayed.
- ▶ Hold down the AIR button and MODE button at the same time in display mode to return to measurement mode.
- ▶ To cancel before finalizing changes to the settings, hold down the AIR button and MODE button at the same time. The product returns to display mode.

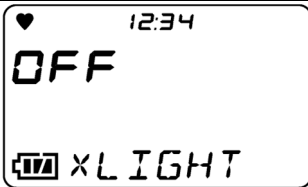
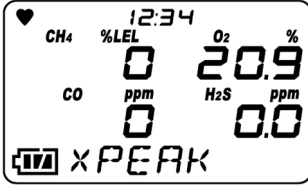
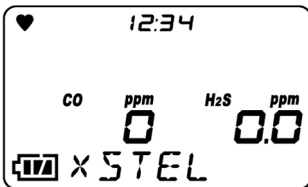
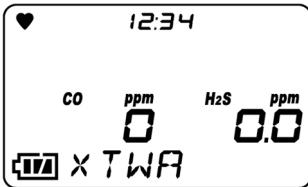
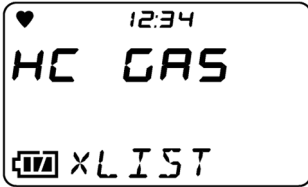
## 6-1-2 Contents displayed in display mode

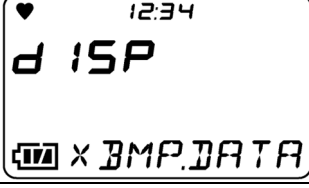
Setting item (Screen notation)	Display contents	LCD display	Reference
Light on/off ([LIGHT])	Turns the light on and off.		'6-2-1 Light on/off'
PEAK value display ([PEAK])	Displays the maximum gas concentration (or minimum oxygen concentration) detected since the power was turned on.		'6-2-2 Clearing PEAK value display'
STEL value display ([STEL]) * Displays only CO and H <sub>2</sub> S.	Displays the STEL value from the present to 15 minutes ago (or when the power was switched on). The STEL value refers to the sum of 15 pieces of average value data for measured values over a period of 60 seconds divided by 15. The value is refreshed every 60 seconds.		----
TWA value display ([TWA]) * Displays only CO and H <sub>2</sub> S.	Displays the TWA value from the present to 8 hours ago (or when the power was switched on). The TWA value refers to the value obtained by calculating the average for measured values over a period of 60 seconds and then dividing the total calculated for a period of 8 hours by 480. The value is refreshed every 60 seconds.		----
Combustible gas conversion setting ([HC GAS]) * Displayed only on models that detect combustible gases	Selects the gas to be converted from the list of gases preregistered in the product.		'6-2-3 Combustible gas conversion setting'
Adjustment data display ([CAL.DATA]) * Displayed with ATEX/IECEX specifications only	Displays the adjusted gas type and adjustment date.		'6-2-4 Adjustment data display'
Bump test data display ([BMP.DATA])	Displays the bump test gas type and the test date.		'6-2-5 Bump test data display'

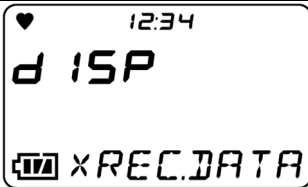
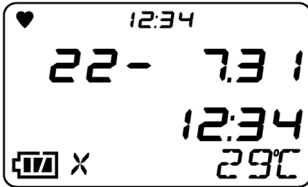
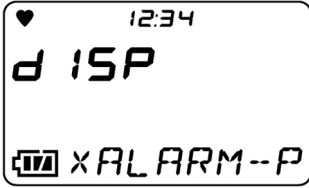

Setting item (Screen notation)	Display contents	LCD display	Reference
Snap log data display ([REC.DATA])	Displays the recorded gas concentration.		'6-2-6 Snap log data display'
Date and time and temperature display ([DATE])	Displays the date, time, and temperature.		----
Alarm setpoint display ([ALARM-P])	Displays various alarm setpoints.		'6-2-7 Alarm setpoint display'

## NOTE

- ▶ The previously measured PEAK and TWA values retained the last time the power was turned off are displayed when the lunch break function is enabled.
- ▶ Combustible gas conversion setting ([HC GAS]) is not displayed for calibration gas types other than CH<sub>4</sub> or i-C<sub>4</sub>H<sub>10</sub>.
- ▶ Bump test data is displayed if the bump test expiration display setting is enabled in user mode.
- ▶ Adjustment data is displayed if the adjustment expiration display setting is enabled in user mode.
- ▶ The temperature displayed in the date and time and temperature display is the internal temperature of the product. This value differs from the actual ambient temperature.

## 6-2 Display mode settings

You can check and change settings by switching from measurement mode to display mode.

### 6-2-1 Light on/off

Turns the light on and off.

The light will go out automatically approximately two minutes after it is turned on.

- 1 Press the **MODE** button in measurement mode to display the **LIGHT** screen.

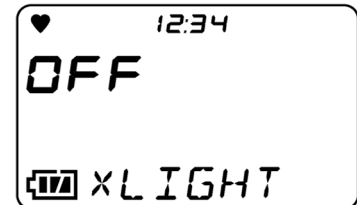

- 2 Press the **AIR** button to turn the light on or off.  
Pressing the AIR button lets you select [On] or [OFF] for the light.  
The default setting is [OFF].

- 3 Press the **MODE** button.  
The light is set on or off and the PEAK screen is displayed.

### 6-2-2 Clearing PEAK value display

This clears the PEAK value (the maximum gas concentration or minimum oxygen concentration measured since the power was turned on).

- 1 Press the **MODE** button several times in measurement mode to display the **PEAK** screen.

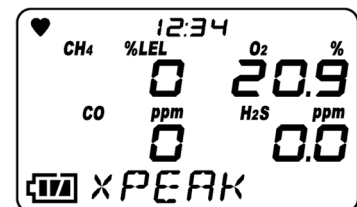

- 2 Hold down the **AIR** button.

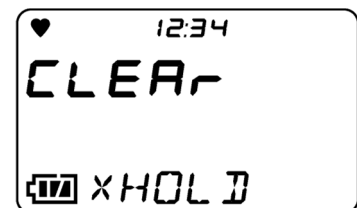

- 3 Release the **AIR** button once [RELEASE] is displayed on the screen.

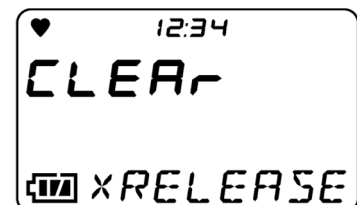

The PEAK value is cleared and the display returns to the screen in Step 1.

### 6-2-3 Combustible gas conversion setting

Combustible gas measurements can be displayed as a concentration of a gas preregistered in the product.

The following combustible gases can be converted:

#### <Combustible gas conversion list>

Gas name	Gas name display	Calibration gas conversion		Conversion when conversion is restricted
		CH <sub>4</sub>	i-C <sub>4</sub> H <sub>10</sub>	
Methane	CH <sub>4</sub>	-	×	○
Isobutane	i-C <sub>4</sub> H <sub>10</sub>	○	-	○
Hydrogen	H <sub>2</sub>	○	○	○
Methanol	CH <sub>3</sub> OH	○	○	×
Acetylene	C <sub>2</sub> H <sub>2</sub>	○	○	○
Ethylene	C <sub>2</sub> H <sub>4</sub>	○	○	○
Ethane	C <sub>2</sub> H <sub>6</sub>	○	×	○
Ethanol	C <sub>2</sub> H <sub>5</sub> OH	○	○	×
Propylene	C <sub>3</sub> H <sub>6</sub>	○	○	○
Acetone	C <sub>3</sub> H <sub>6</sub> O	○	○	×
Propane	C <sub>3</sub> H <sub>8</sub>	○	×	○
Butadiene	C <sub>4</sub> H <sub>6</sub>	○	○	○
Cyclopentane	C <sub>5</sub> H <sub>10</sub>	○	○	○
Benzene	C <sub>6</sub> H <sub>6</sub>	○	○	×
N-hexane	n-C <sub>6</sub> H <sub>14</sub>	○	○	○
Toluene	C <sub>7</sub> H <sub>8</sub>	○	○	×
N-heptane	n-C <sub>7</sub> H <sub>16</sub>	○	○	○
Xylene	C <sub>8</sub> H <sub>10</sub>	○	○	×
N-nonane	n-C <sub>9</sub> H <sub>20</sub>	○	○	×
Ethyl acetate	EtAc	○	○	×
Isopropyl alcohol	IPA	○	○	×
Methyl ethyl ketone	MEK	○	○	×
Methyl methacrylate	MMA	○	○	×
Dimethyl ether	DME	○	○	×
Methyl isobutyl ketone	MIBK	○	○	×
Tetrahydrofuran	THF	○	○	×
Normal pentane	n-C <sub>5</sub> H <sub>12</sub>	○	○	○

## CAUTION

- On models that detect combustible gases, the screen shown on the right may be displayed with the buzzer sounding and LED flashing after the power is turned on or gas adjustment is performed. If this screen is displayed, some combustible gases cannot be converted using the combustible gas conversion function. For information on the types of gases that cannot be converted, refer to '<Combustible gas conversion list>' shown above.

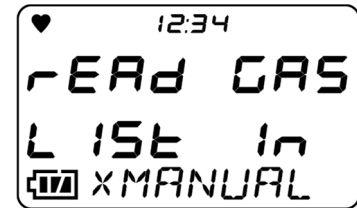

If the screen shown on the right appears, the alarm can be temporarily reset by pressing the MODE button (or after five seconds if no buttons are pressed).

Note that the screen shown on the right appears when the combustible gas sensor is placed under the poisoning effects of silicone compounds or halides. If the screen shown on the right is displayed, the conversion function can be used only for those gas types marked "O" in the "Conversion when conversion is restricted" column. To continue to use the conversion function for gas types marked "x", contact Riken Keiki.

## NOTE

- ▶ Combustible gas conversion selection is displayed for CH<sub>4</sub> and i-C<sub>4</sub>H<sub>10</sub>.
- ▶ This does not appear if display mode item display in user mode is disabled. (Refer to '6-4-10 Display mode item display on/off'.)
- The default settings are as follows:
  - Japan EX specifications: Display mode item display: [OFF]
  - ATEX/IECEX specifications: Display mode item display: [On]
- ▶ To cancel before finalizing changes to the settings, hold down the AIR button and MODE button at the same time. The product returns to display mode.
- ▶ The alarm accuracy and alarm delay time shown in the specifications list apply only to the calibration gas.
- ▶ The concentration display when converted should be treated as approximate. If gas conversion is set, the reading accuracy for the product will not be achieved.
- ▶ For information on the list of gases that can be converted, refer to '<Combustible gas conversion list>'.
- ▶ The product specifications vary depending on the combustible gas detected. Depending on the product specifications, certain gas types may not be converted. Refer to '<Combustible gas conversion list>'.
- ▶ Even if combustible gas conversion is set, readings will be displayed if other combustible gases are present in the usage environment.
- ▶ If hydrogen (H<sub>2</sub>) is set for gas conversion, readings will not be displayed for gases marked "x" in the "Conversion when conversion is restricted" column in '<Combustible gas conversion list>', even if such gases are present in the usage environment.

- 1 Press the MODE button several times in measurement mode to display the LIST screen.

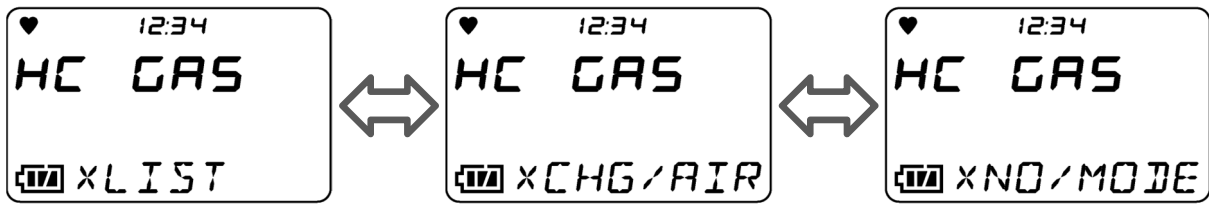

- 2 Press the AIR button to select the combustible gas to be converted.

Pressing the AIR button cycles the display through the list of combustible gases.

The default setting is the calibration gas for the combustible gas sensor.

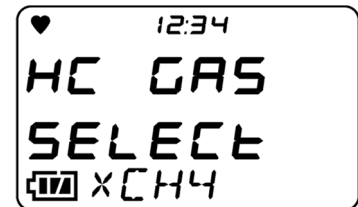

- 3 Press the MODE button.

Combustible gas conversion is set.

[END] appears and the display returns to the screen in Step 1.

### 6-2-4 Adjustment data display

Displays the date on which gas adjustment was performed.

#### NOTE

- ▶ This is displayed with ATEX/IECEX specifications.
- ▶ Adjustment data is not displayed if the adjustment expiration display setting is disabled in user mode. The default setting is [On].

- 1 Press the MODE button several times in measurement mode to display the CAL.DATA screen.

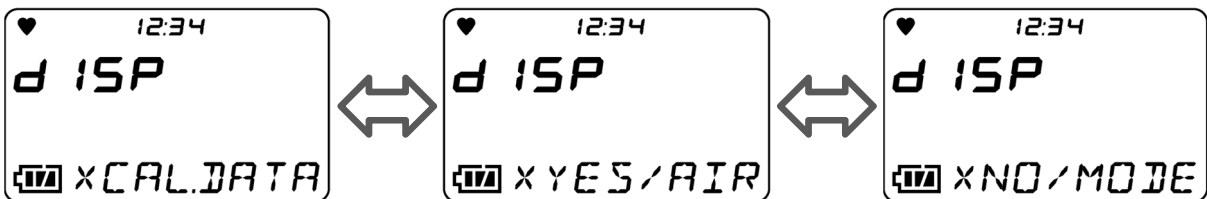

- 2 Press the AIR button.

Pressing the AIR button cycles the display through [CH4 or HC] → [O2] → [H2S] → [CO] → [CH4 or HC] in sequence.

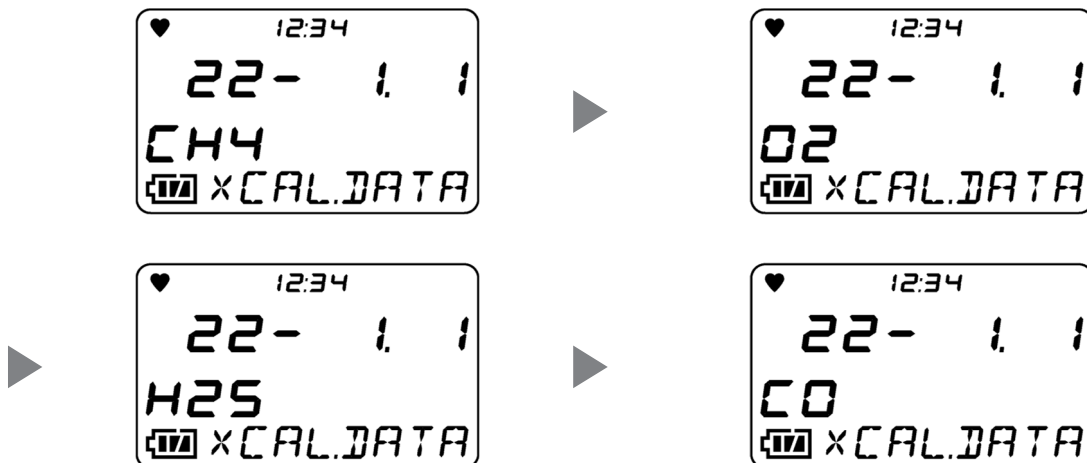

- 3 Press the MODE button.

The display returns to the screen in Step 1.

### 6-2-5 Bump test data display

Displays the date on which the bump test was performed.

#### NOTE

- ▶ Bump test data is not displayed if the bump test expiration display setting is disabled in user mode. The default setting is [OFF].
- ▶ The bump test data is also updated automatically when gas adjustment is performed.

- 1 Press the **MODE** button several times in measurement mode to display the **BMP.DATA** screen.

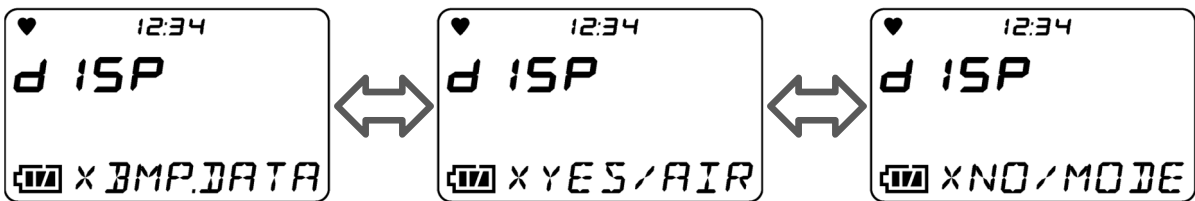

- 2 Press the **AIR** button.

Pressing the AIR button cycles the display through [CH4] → [O2] → [H2S] → [CO] → [CH4] in sequence.



- 3 Press the **MODE** button.

The display returns to the screen in Step 1.

## 6-2-6 Snap log data display

Snap log data is data for gas concentrations recorded during measurement.

Select the recorded date, time, and memory number to display the corresponding gas concentration.

### NOTE

- ▶ For information on how to record snap log data, refer to '5-5-3 Snap log recording'.

- 1 Press the **MODE** button several times in measurement mode to display the REC.DATA screen.

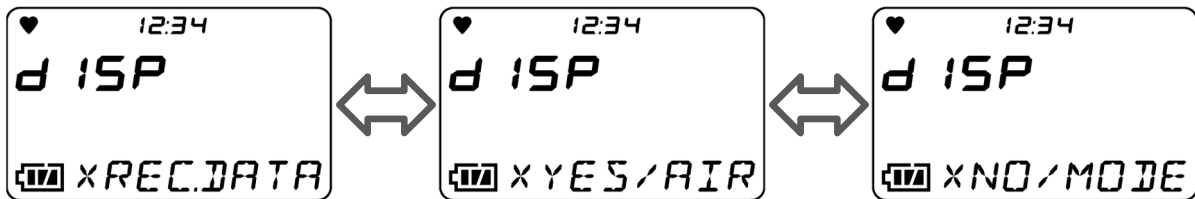

- 2 Press the **AIR** button.

Pressing the AIR button cycles through the log data menu items.

Select the log data to be checked.

The log data menu items displayed are the date, time, and memory number.

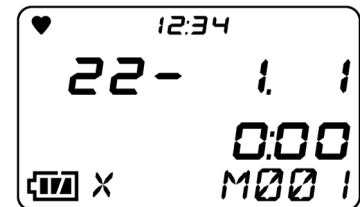

- 3 Press the **MODE** button.

The gas concentration is displayed for the log data selected.

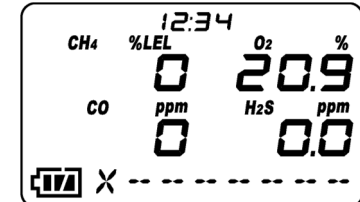

- 4 Press the **MODE** button.

The display returns to the log data menu.

To continue and display other log data, repeat the procedure in Steps 2 - 4.

- 5 Hold down the **AIR** button and **MODE** button at the same time.

The display returns to the screen in Step 1.



**6-2-7 Alarm setpoint display**

This allows alarm setpoints to be displayed and testing of LED, buzzer, and vibrator operations.

**NOTE**

- ▶ [TWA] and [STEL] are displayed only on models that detect gases other than combustible gases and oxygen.
- ▶ Pressing the AIR button and the MODE button at the same time while an alarm setpoint is displayed lets you test the corresponding alarm. Press either button to reset the alarm.

**1 Press the MODE button several times in measurement mode to display the ALARM-P screen.**

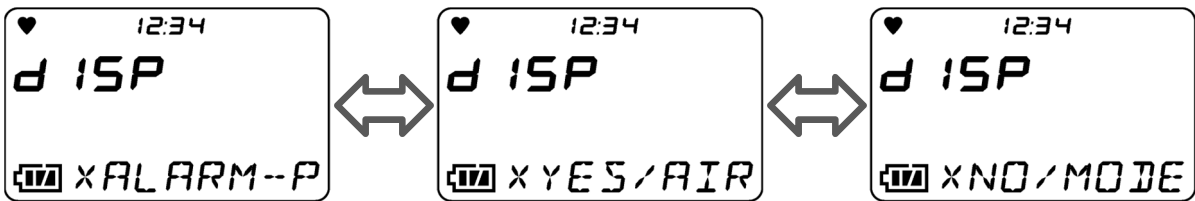

**2 Press the AIR button.**

Pressing the AIR button cycles the display through [F.S.] (FULL SCALE) → [WARNING (1st alarm)] → [ALARM (2nd alarm)] → [ALARM H (3rd alarm)] → [STEL] → [TWA] → [F.S.] (FULL SCALE) in sequence.

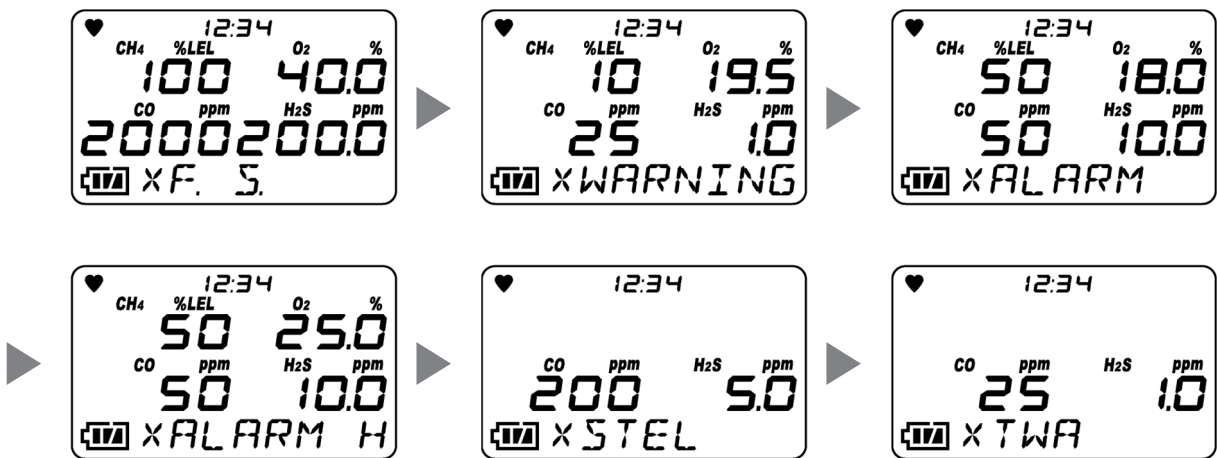

**3 Press the MODE button.**

The display returns to the screen in Step 1.

## 6-3 User mode

User mode lets you set the date and time, alarm setpoints, and other settings.

### 6-3-1 Switching to user mode

- 1 With the power turned off, press the AIR button and POWER button at the same time.

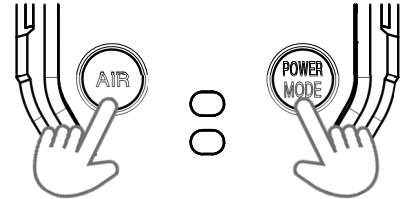

- 2 Release the buttons when the buzzer blips.  
The power turns on, and the user mode menu appears.

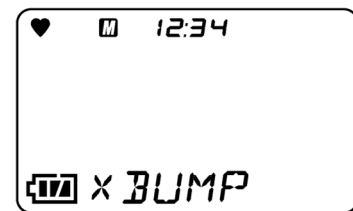

- 3 Press the AIR button to select the required setting item, then press the MODE button.  
The user mode setting screen is displayed.

#### NOTE

- ▶ To return while configuring user mode menu settings, hold down the AIR button and MODE button at the same time.
- ▶ A password input screen is displayed to access user mode if the password setting is enabled. Press the AIR button to select the number for the currently selected digit, then press the MODE button to confirm. The user mode menu is displayed once the (four-digit) password has been correctly entered. For information on setting the password, refer to '6-4-14 Password setting'. The default password settings are as follows:
  - Japan EX specifications: Default: [On], Password: [0000]
  - ATEX/IECEX specifications: Default: [OFF]

#### <Switching from user mode to measurement mode>



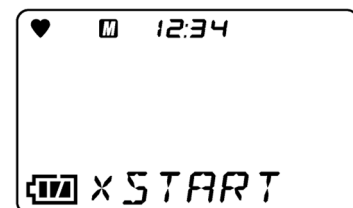

- 1 Press the AIR button on the user mode menu to select [START], then press the MODE button.

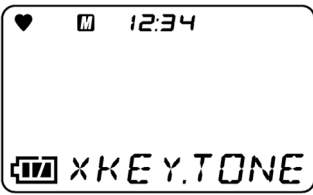
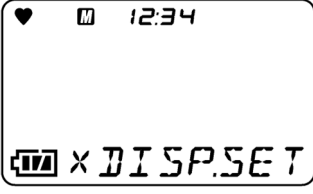
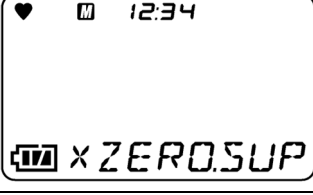
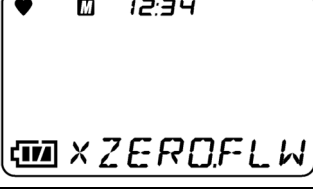

The product operates in the same way as at power-on and switches to measurement mode.

## 6-3-2 User mode setting items

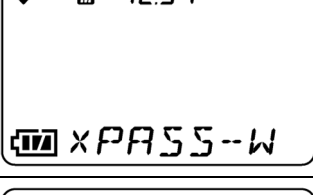
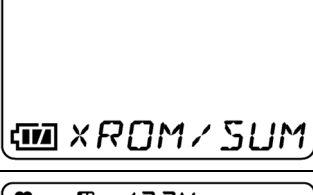
Setting item (Screen notation)	LCD display	Reference
Bump test ([BUMP])		'6-4-1 Bump test'
Gas adjustment ([GAS CAL])		'6-4-2 Gas adjustment'
Adjustment expiration setting ([CAL SET]) * Displayed with ATEX/IECEX specifications only		'6-4-3 Adjustment expiration setting'
Bump test setting ([BUMP.SET])		'6-4-4 Bump test setting'
Alarm setpoint setting ([ALARM-P])		'6-4-5 Alarm setpoint setting'
Lunch break on/off ([LUNCH])		'6-4-6 Lunch break on/off'
Confirmation beep setting ([BEEP])		'6-4-7 Confirmation beep setting'
LCD lighting time setting ([BL TIME])		'6-4-8 LCD lighting time setting'

Setting item (Screen notation)	LCD display	Reference
Key operation tone on/off ([KEY.TONE])		'6-4-9 Key operation tone on/off'
Display mode item display on/off ([DISP.SET])		'6-4-10 Display mode item display on/off'
Zero suppression on/off ([ZERO.SUP])		'6-4-11 Zero suppression on/off'
Zero follower on/off ([ZERO.FLW])		'6-4-12 Zero follower on/off'
Date and time setting ([DATE])		'6-4-13 Date and time setting'
Password setting ([PASS-W])		'6-4-14 Password setting'
ROM/SUM display ([ROM/SUM])		'6-4-15 ROM/SUM display'
Measurement start ([START])		-----

## 6-4 User mode settings

User mode allows settings to be changed to increase usability.

### 6-4-1 Bump test

The product includes a function for performing a bump test (function check). User mode lets you perform bump tests and switch from a bump test to measurement mode.

The product automatically switches to measurement mode following a successful bump test.

\* The product does not automatically switch to measurement mode if multiple cylinders are set.

For information on the bump test procedure, refer to '7-3 Bump test'.

#### NOTE

- ▶ To exit setting, press the AIR button to select [ESCAPE], then press the MODE button. The display returns to the user mode menu.

### 6-4-2 Gas adjustment

The product can be adjusted using AUTO adjustment with preset gas concentrations in addition to fresh air adjustment.

Gas adjustment requires dedicated tools and a calibration gas. Contact Riken Keiki.

The product automatically switches to measurement mode following a successful gas adjustment.

\* The product does not automatically switch to measurement mode if multiple cylinders are set.

For information on the gas adjustment procedure, refer to '7-2 Gas adjustment'.

#### NOTE

- ▶ To exit setting, press the AIR button to select [ESCAPE], then press the MODE button. The display returns to the user mode menu.

### 6-4-3 Adjustment expiration setting

The gas adjustment expiration display can be enabled or disabled, the adjustment expiration interval can be set, and the operation performed after adjustment has expired can be set.

#### NOTE

- ▶ The adjustment expiration setting is a function available with ATEX/IECEX specifications. It is displayed with ATEX/IECEX specifications.

Adjustment expiration setting is configured in [CAL SET] in user mode.  
The following menu displayed in [CAL SET] allows individual items to be set.

### <[CAL SET] menu>

User mode menu

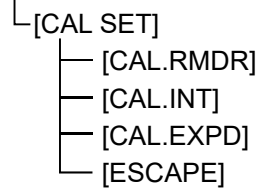

### <[CAL SET] menu selection>

- 1 Press the AIR button on the user mode menu to select [CAL SET], then press the MODE button.

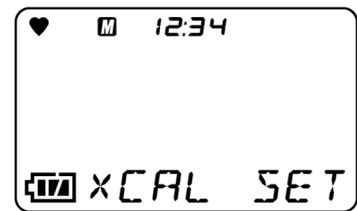

- 2 Press the AIR button to select the required setting item, then press the MODE button.

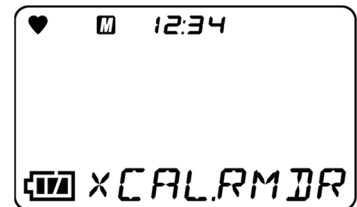

Screen notation	LCD display	Reference
[CAL.RMDR]		'Adjustment expiration display on/off'
[CAL.INT]		'Adjustment expiration interval setting'
[CAL.EXPD]		'Operation setting after adjustment expiration'
[ESCAPE]		----

**NOTE**

- ▶ To exit the [CAL SET] menu, press the AIR button to select [ESCAPE], then press the MODE button. The display returns to the user mode menu.

**<Adjustment expiration display on/off>**

This enables and disables the adjustment expiration display.

- 1 Press the AIR button on the [CAL SET] menu to select [CAL.RMDR], then press the MODE button.**
- 2 Press the AIR button to select on or off for the adjustment expiration display.**  
Pressing the AIR button lets you select [On] or [OFF] for the adjustment expiration display.  
The default setting is [On].
- 3 Press the MODE button.**  
[END] appears and the display returns to the screen in Step 1.

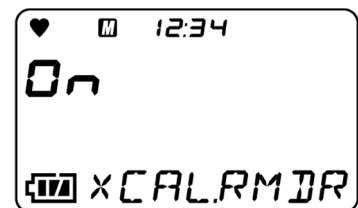
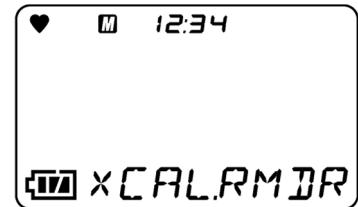
**<Adjustment expiration interval setting>**

This sets the interval until the adjustment expiration notification is given after performing gas adjustment.

- 1 Press the AIR button on the [CAL SET] menu to select [CAL.INT], then press the MODE button.**
- 2 Press the AIR button to select the number of days until adjustment expiration.**  
Pressing the AIR button lets you select the adjustment expiration interval from [1] - [1000] days.  
The default setting is [365] days.
- 3 Press the MODE button.**  
[END] appears and the display returns to the screen in Step 1.

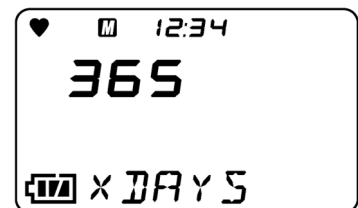
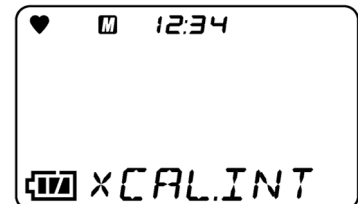

### <Operation setting after adjustment expiration>

This lets you select the operation performed after adjustment has expired.

- 1 Press the AIR button on the [CAL SET] menu to select [CAL.EXPD], then press the MODE button.

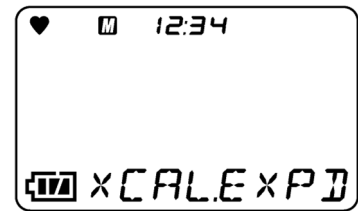

- 2 Press the AIR button to select the operation performed after adjustment has expired.

Pressing the AIR button displays the following operations performed after adjustment expiration:

- [CONFIRM]: The behavior differs depending on the operation. Press the AIR button to proceed to measurement mode. Press the MODE button to proceed to AUTO adjustment cylinder settings.
- [CANT.USE]: Measurement mode is not available. Either press the MODE button or wait six seconds to automatically proceed to AUTO adjustment cylinder settings.
- [NONE]: The behavior differs depending on the operation. When adjustment expiration is indicated, press the MODE button to proceed to AUTO adjustment cylinder settings. If you do nothing, the product will proceed to measurement mode after about six seconds.

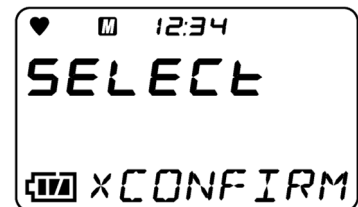

The default setting is [CONFIRM].

- 3 Press the MODE button.

[END] appears and the display returns to the screen in Step 1.



**6-4-4 Bump test setting**

Bump test setting is configured in [BUMP.SET] in user mode.  
 The following menu displayed in [BUMP.SET] allows individual items to be set.

**<[BUMP.SET] menu>**

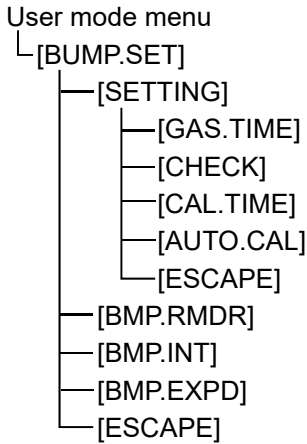

**<[BUMP.SET] menu selection>**

- 1 Press the AIR button on the user mode menu to select [BUMP.SET], then press the MODE button.

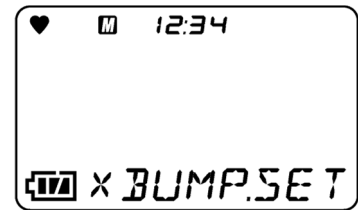

- 2 Press the AIR button to select the required setting item, then press the MODE button.

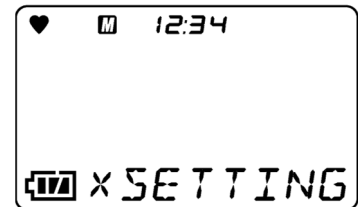

Screen notation	LCD display	Reference
[SETTING]	<p>The LCD display shows a heart icon, a battery icon, and the time '12:34'. At the bottom, it displays 'AIR X SETTING'.</p>	'<Bump time selection> '<Bump tolerance selection> '<Gas adjustment time selection after bump test> '<Gas adjustment after bump test on/off>'
[BMP.RMDR]	<p>The LCD display shows a heart icon, a battery icon, and the time '12:34'. At the bottom, it displays 'AIR X BMP.RMDR'.</p>	'<Bump test expiration display on/off>'

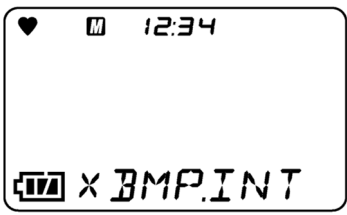
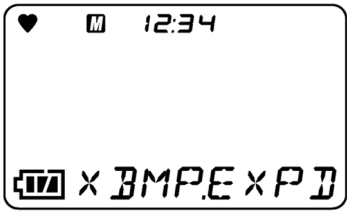
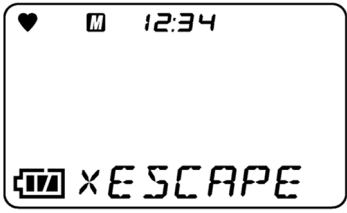
Screen notation	LCD display	Reference
[BMP.INT]	 <p>The LCD display shows a heart icon, a battery level icon, and the time 12:34. Below this, it displays a menu icon followed by 'X BMP.INT'.</p>	'<Bump test expiration interval selection>'
[BMP.EXPD]	 <p>The LCD display shows a heart icon, a battery level icon, and the time 12:34. Below this, it displays a menu icon followed by 'X BMP.EXPD'.</p>	'<Operation setting after bump test expiration>'
[ESCAPE]	 <p>The LCD display shows a heart icon, a battery level icon, and the time 12:34. Below this, it displays a menu icon followed by 'X ESCAPE'.</p>	----

#### NOTE

- ▶ To exit the [BUMP.SET] menu, press the AIR button to select [ESCAPE], then press the MODE button. The display returns to the user mode menu.
- ▶ To exit the [SETTING] menu, press the AIR button to select [ESCAPE], then press the MODE button. The display returns to the [BUMP.SET] menu.

**<Bump time selection>**

This sets the time for introducing the test gas.

- 1 Press the AIR button on the [BUMP.SET] menu to select [SETTING], then press the MODE button.**  
The [SETTING] menu is displayed.
  
- 2 Press the AIR button to select [GAS.TIME], then press the MODE button.**
  
- 3 Press the AIR button to select the bump time.**  
Pressing the AIR button lets you select a bump time from [30], [45], [60], and [90] seconds.  
The default setting is [30] seconds.
  
- 4 Press the MODE button.**  
[END] appears and the display returns to the screen in Step 2.
  
- 5 Press the AIR button to select [ESCAPE], then press the MODE button.**  
The display returns to the screen in Step 1.

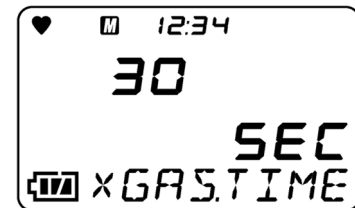
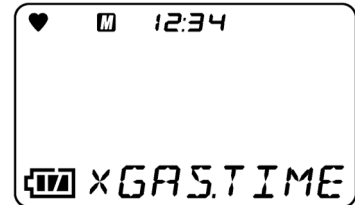
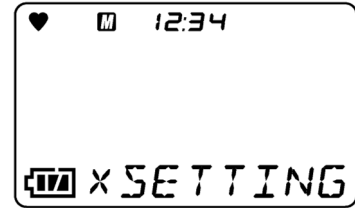

### <Bump tolerance selection>

This sets the threshold for checking the test gas.

Gases other than oxygen: Adjustment concentration  $\pm$  (adjustment concentration  $\times$  bump tolerance)

Oxygen: Adjustment concentration  $\pm$  (difference between adjustment concentration and 20.9 %  $\times$  bump tolerance)

- 1 Press the AIR button on the [BUMP.SET] menu to select [SETTING], then press the MODE button.

The [SETTING] menu is displayed.

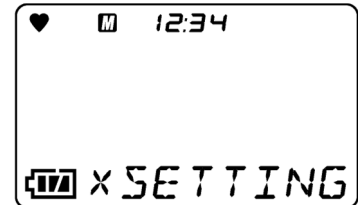

- 2 Press the AIR button to select [CHECK], then press the MODE button.

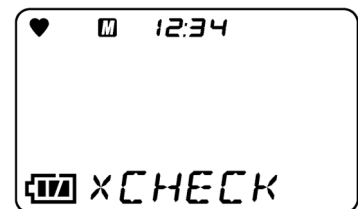

- 3 Press the AIR button to select the bump tolerance.

Pressing the AIR button lets you select a bump tolerance from [10], [20], [30], [40], and [50] %.

The default setting is [50] %.

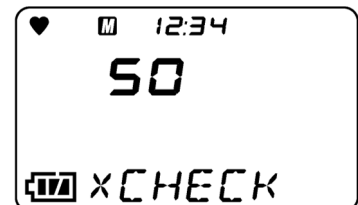

- 4 Press the MODE button.

[END] appears and the display returns to the screen in Step 2.

- 5 Press the AIR button to select [ESCAPE], then press the MODE button.

The display returns to the screen in Step 1.

### <Gas adjustment time selection after bump test>

This selects the time for gas adjustment after a bump test has failed.

- 1 **Press the AIR button on the [BUMP.SET] menu to select [SETTING], then press the MODE button.**  
The [SETTING] menu is displayed.
- 2 **Press the AIR button to select [CAL.TIME], then press the MODE button.**
- 3 **Press the AIR button to select the gas adjustment time after bump test.**  
Pressing the AIR button lets you select [90] or [120] seconds as the gas adjustment time after a bump test.  
The default setting is [90] seconds.
- 4 **Press the MODE button.**  
[END] appears and the display returns to the screen in Step 2.
- 5 **Press the AIR button to select [ESCAPE], then press the MODE button.**  
The display returns to the screen in Step 1.

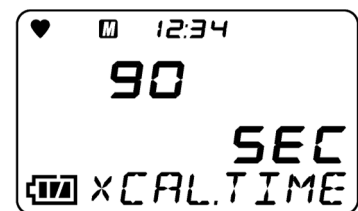
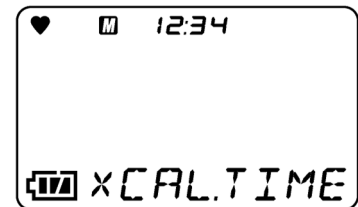
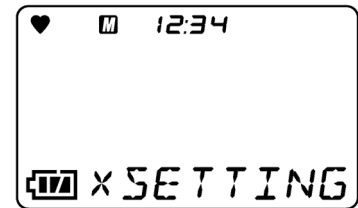

**<Gas adjustment after bump test on/off >**

This enables and disables the function for automatic gas adjustment if a bump test fails.

- 1 Press the AIR button on the [BUMP.SET] menu to select [SETTING], then press the MODE button.**  
The [SETTING] menu is displayed.
- 2 Press the AIR button to select [AUTO.CAL], then press the MODE button.**
- 3 Press the AIR button to enable or disable gas adjustment after a bump test fails.**  
Pressing the AIR button lets you select [On] or [OFF] for gas adjustment after a bump test fails.  
The default setting is [On].
- 4 Press the MODE button.**  
[END] appears and the display returns to the screen in Step 2.
- 5 Press the AIR button to select [ESCAPE], then press the MODE button.**  
The display returns to the screen in Step 1.

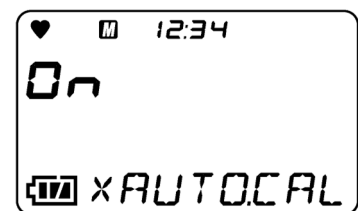
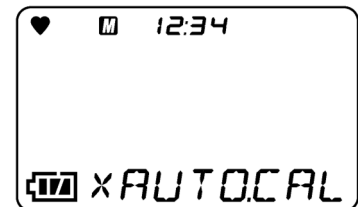
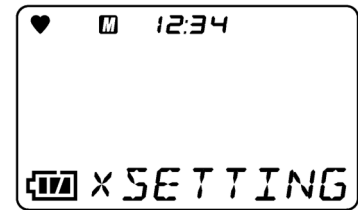

**<Bump test expiration display on/off>**

This enables and disables the bump test expiration display.

- 1 **Press the AIR button on the [BUMP.SET] menu to select [BMP.RMDR], then press the MODE button.**
- 2 **Press the AIR button to enable or disable the bump test expiration display.**  
Pressing the AIR button lets you select [On] or [OFF] for the bump test expiration display.  
The default setting is [OFF].
- 3 **Press the MODE button.**  
[END] appears and the display returns to the screen in Step 1.

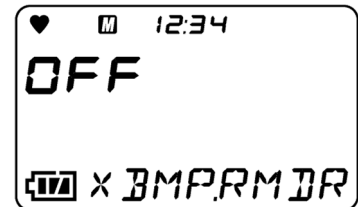
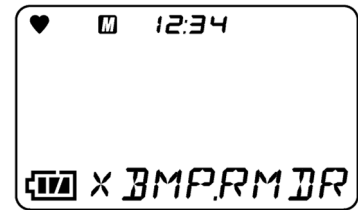
**<Bump test expiration interval selection>**

This sets the number of days until bump test expiration is displayed after a bump test.

- 1 **Press the AIR button on the [BUMP.SET] menu to select [BMP.INT], then press the MODE button.**
- 2 **Press the AIR button to select the number of days until bump test expiration.**  
Pressing the AIR button lets you select the bump test expiration interval from [0] - [365] days.  
The default setting is [30] days.
- 3 **Press the MODE button.**  
[END] appears and the display returns to the screen in Step 1.

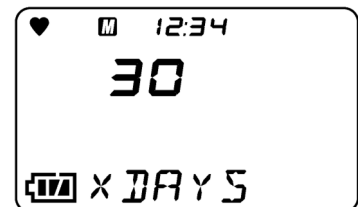
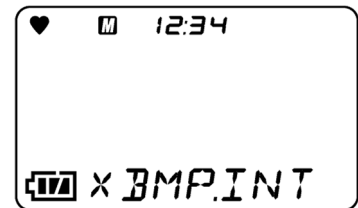

### <Operation setting after bump test expiration>

This selects the operation after the bump test expiration display.

- 1 Press the AIR button on the [BUMP.SET] menu to select [BMP.EXPD], then press the MODE button.

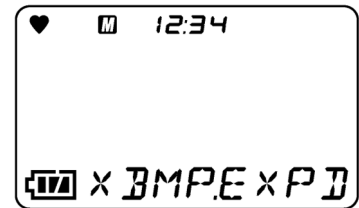

- 2 Press the AIR button to select the operation performed after bump test expiration.

Pressing the AIR button displays the following operations in sequence:

- [CONFIRM]: The behavior differs depending on the operation. Press the AIR button to proceed to measurement mode. Press the MODE button to proceed to bump test cylinder settings.
- [CANT.USE]: Measurement mode is not available. Press the MODE button or wait six seconds to automatically proceed to bump test cylinder settings.
- [NONE]: The behavior differs depending on the operation. When adjustment expiration is indicated, press the MODE button to proceed to bump test cylinder settings. If you do nothing, the product will proceed to measurement mode after about six seconds.

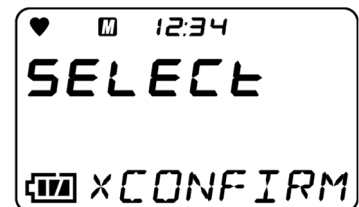

The default setting is [CONFIRM].

- 3 Press the MODE button.

[END] appears and the display returns to the screen in Step 1.



**6-4-5 Alarm setpoint setting**

Sets the first, second, and third alarm setpoints and STEL and TWA alarm setpoints, and also allows the setpoint settings to be reset to their default values.

**<Alarm setpoint setting>**

Alarm setpoints can be set using one-digit units.

Detection target gas	1 digit	Lower limit	Upper limit
Combustible gas (HC/CH <sub>4</sub> )	1 %LEL	1 %LEL (Recommended range: at least 10 %LEL)	60 %LEL
Carbon monoxide (CO)	1 ppm	12 ppm (Recommended range: at least 25 ppm)	2,000 ppm
Hydrogen sulfide (H <sub>2</sub> S)	0.1 ppm	0.5 ppm (Recommended range: at least 1.0 ppm)	200.0 ppm

Detection target gas	1 digit	First/second alarm		Third alarm	
		Lower limit	Upper limit	Lower limit	Upper limit
Oxygen (O <sub>2</sub> )	0.1 %	0.0 %	20.0 %	21.8 %	25.0 %

**NOTE**

- ▶ Set the alarm setpoints as follows: First alarm ≤ second alarm ≤ third alarm (first alarm ≥ second alarm for oxygen)
- ▶ Use the product with the alarms set to within a range compatible with device performance. Alarm setpoints below the recommended range may result in false alarms.

**1 Press the AIR button on the user mode menu to select [ALARM-P], then press the MODE button.**

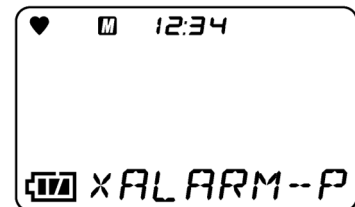

**2 Press the AIR button to select the gas type, then press the MODE button.**  
Pressing the AIR button alternately displays the detection target gas and the alarm setpoint reset screen.

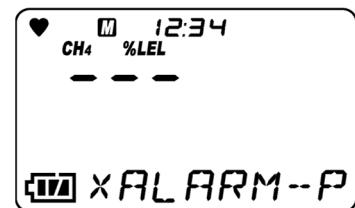

**3 Press the AIR button to select the first alarm setpoint numerical value, then press the MODE button.**

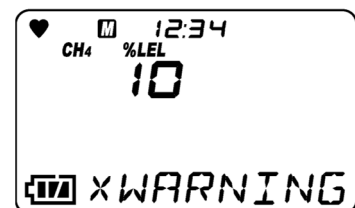

**4 Press the AIR button to select the second alarm setpoint numerical value, then press the MODE button.**

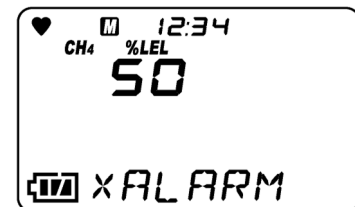

**5 Press the AIR button to select the third alarm setpoint numerical value, then press the MODE button.**

For toxic gases, the setting screens for [STEL] and [TWA] are subsequently displayed. Set these in the same way. [END] appears and the display returns to the screen in Step 2.

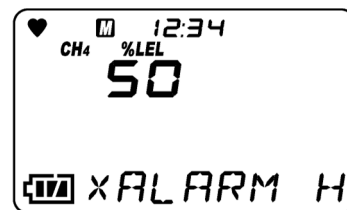

**6 To exit setting, press the AIR button to select [ESCAPE], then press the MODE button.**

The display returns to the user mode menu.

---

## NOTE

- ▶ For more information on how to reset alarm setpoints, refer to '<Resetting alarm setpoints>' on the next page. The alarm setpoint reset ([DEF.ALMP]) screen may not appear if the product is not set correctly. If this occurs, contact Riken Keiki.
  - ▶ For more information on alarm setpoints, refer to '4 Alarm Activation'.
-

### <Resetting alarm setpoints>

This restores alarm setpoints to their default settings.

- 1 Press the AIR button on the user mode menu to select [ALARM-P], then press the MODE button.

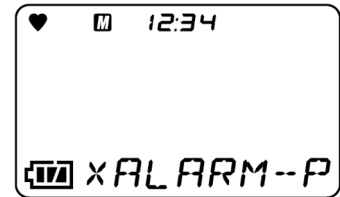

- 2 Press the AIR button several times to select [DEF.ALMP], then press the MODE button.

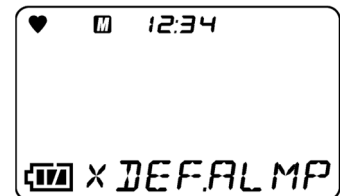

- 3 Press the MODE button.

To cancel the reset, press the AIR button.

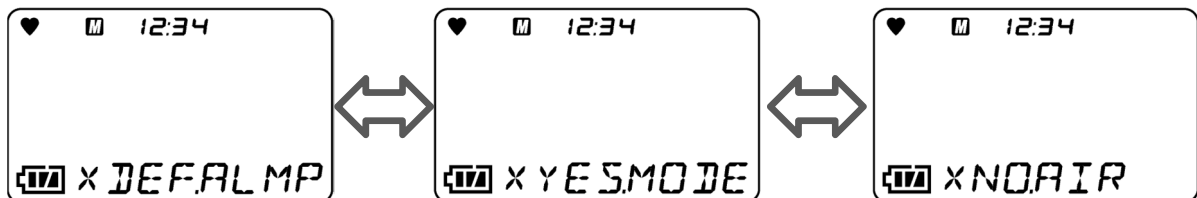

- 4 Press the MODE button.

To cancel alarm setpoint resetting, press the AIR button.

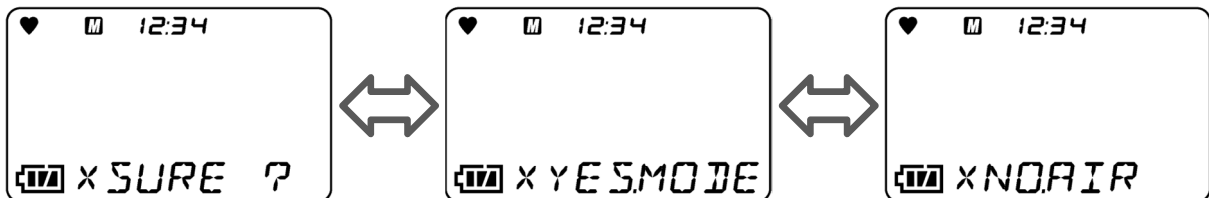

The alarm setpoint is reset.

[END] appears and the display returns to the screen in Step 2.

- 5 Press the AIR button to select [ESCAPE], then press the MODE button.

The display returns to the user mode menu.

### 6-4-6 Lunch break on/off

This lets you enable and disable the lunch break function. The lunch break function retains TWA and PEAK values from the last time the power was turned off and loads them to continue measurement the next time the power is turned on.

- 1 Press the AIR button on the user mode menu to select [LUNCH], then press the MODE button.

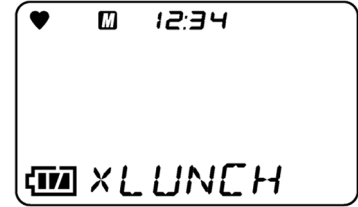

- 2 Press the AIR button to select on or off for the lunch break function.

Pressing the AIR button lets you select [On] or [OFF] for the lunch break function.

The default setting is [OFF].

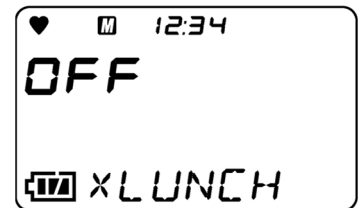

- 3 Press the MODE button.

[END] appears and the display returns to the user mode menu.

#### NOTE

- ▶ When the lunch break setting is enabled, a confirmation screen will appear next time the power is turned on to confirm whether to retain the TWA and PEAK values from the last time the power was turned off and resume measurement or to reset the values from the last time the power was turned off.

### 6-4-7 Confirmation beep setting

This function provides an audible indication of whether the product is operating normally.

The buzzer sounds at preset intervals while measurement is underway. [BMP/CAL], [ALM.ALRT], and [B/C/ALM] can also be set to use the following functions:

#### 1. [BMP/CAL]

- Starts operation when adjustment has expired with the adjustment expiration display enabled or when the bump test has expired with the bump test expiration display enabled.
- Once operation starts, it does not stop until adjustment or bump testing has been performed for all of the gas types supported. (Excludes H<sub>2</sub> canceling.\*)
- The LED lights up for about one second for each interval set.

#### 2. [ALM.ALRT]

- Starts operation when a gas alarm is triggered. (Includes negative sensor failures.)
- Once operation starts, it does not stop until adjustment or bump testing has been performed for all of the gas types supported. (Excludes H<sub>2</sub> canceling.\*)
- The LED lights up for about one second for each interval set.

#### 3. [B/C/ALM]

- Starts operation when adjustment has expired with the adjustment expiration display enabled or when the bump test has expired with the bump test expiration display enabled.
- Once operation starts, it does not stop until adjustment or bump testing has been performed for all of the gas types supported. (Excludes H<sub>2</sub> canceling.\*)
- Starts operation when a gas alarm is triggered. (Includes negative sensor failures.)
- The LED lights up for about one second for each interval set.

\* Hydrogen (H<sub>2</sub>) gas is not included in the stop conditions when using the carbon monoxide sensor (ESR-A1CP) equipped with a hydrogen interference correction function.

Confirmation beep setting is configured in [BEEP] in user mode.  
 The following menu displayed in [BEEP] allows individual items to be set.

**<[BEEP] menu>**

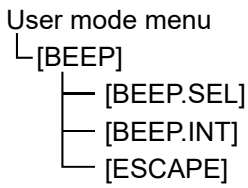

**<[BEEP] menu selection>**

- 1 Press the AIR button on the user mode menu to select [BEEP], then press the MODE button.

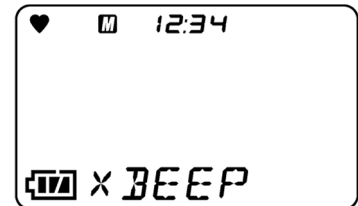

- 2 Press the AIR button to select the required setting item, then press the MODE button.

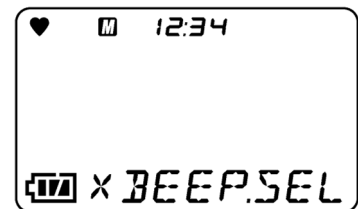

Screen notation	LCD display	Reference
[BEEP.SEL]		'<Beep operation setting>'
[BEEP.INT]		'<Beep interval setting>'
[ESCAPE]		----

**NOTE**

- ▶ To exit the [BEEP] menu, press the AIR button to select [ESCAPE], then press the MODE button. The display returns to the user mode menu.

### <Beep operation setting>

This lets you set the confirmation beep operation.

However, altering the beep operation setting will stop the [BMP/CAL], [ALM.ALRT], and [B/C/ALM] operations.

- 1 Press the AIR button in the [BEEP] menu to select [BEEP.SEL], then press the MODE button.

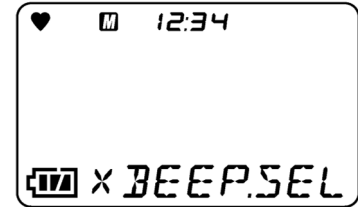

- 2 Press the AIR button to select the confirmation beep operation.

Pressing the AIR button displays the following operations in sequence:

- [OFF]
- [LED] (LED only)
- [BUZZER] (buzzer only)
- [LED+BUZ] (LED and buzzer)
- [BMP/CAL]
- [ALM.ALRT]
- [B/C/ALM]

The default setting is [OFF].

- 3 Press the MODE button.

[END] appears and the display returns to the screen in Step 1.



### <Beep interval setting>

This lets you set the interval between confirmation beeps.

- 1 Press the AIR button on the [BEEP] menu to select [BEEP.INT], then press the MODE button.

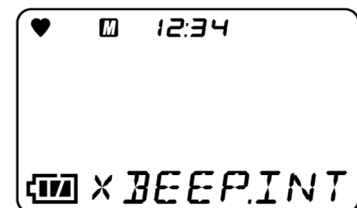

- 2 Press the AIR button to select the beep interval.

Pressing the AIR button lets you select a beep interval of [0.5] or from [1] - [99] minutes.

The default setting is [5] minutes.

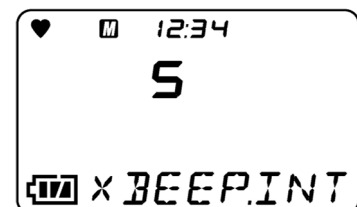

- 3 Press the MODE button.

[END] appears and the display returns to the screen in Step 1.

### 6-4-8 LCD lighting time setting

The duration for which the LCD display backlight remains lit can be set.

- 1 Press the AIR button on the user mode menu to select [BL TIME], then press the MODE button.

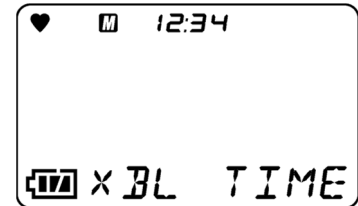

- 2 Press the AIR button to select the backlight lighting time. Pressing the AIR button lets you select a backlight lighting time of [OFF] or from [1] - [255] seconds. The default setting is [30] seconds.

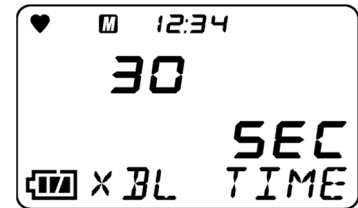

- 3 Press the MODE button. [END] appears and the display returns to the user mode menu.

### 6-4-9 Key operation tone on/off

This enables and disables the key operation tone.

- 1 Press the AIR button on the user mode menu to select [KEY.TONE], then press the MODE button.

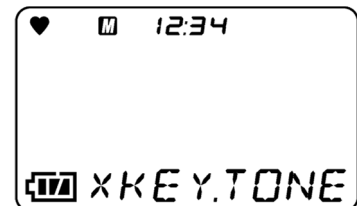

- 2 Press the AIR button to select on or off for the key operation tone. Pressing the AIR button lets you select [On] or [OFF] for the key operation tone. The default setting is [On].

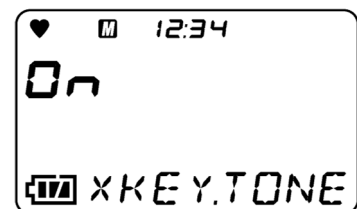

- 3 Press the MODE button. [END] appears and the display returns to the user mode menu.



### 6-4-10 Display mode item display on/off

This lets you set whether display mode items that can be set are displayed or hidden. When disabled, items such as combustible gas conversion setting ([HC GAS]) are not displayed in display mode.

- 1 Press the AIR button on the user mode menu to select [DISP.SET], then press the MODE button.

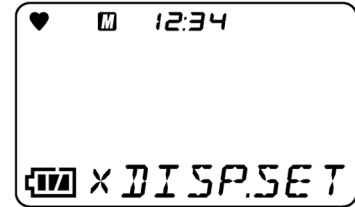

- 2 Press the AIR button to enable or disable the display mode item display.

Pressing the AIR button lets you select [On] or [OFF] for the display mode item display.

Japan EX specifications are set to [OFF]. ATEX/IECEX specifications are set to [On].

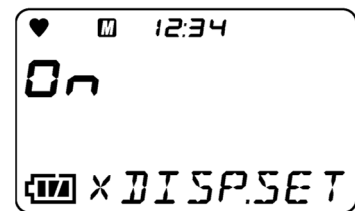

- 3 Press the MODE button.

[END] appears and the display returns to the user mode menu.

## 6-4-11 Zero suppression on/off

This enables and disables zero suppression (or air suppression with an oxygen sensor).

Gas detection sensors are affected by environmental factors such as temperature and humidity characteristics. They are also substantially affected by the interference of the target gas. Environmental and interference effects may cause the product reading to fluctuate around zero.

The zero suppression function is designed to suppress notifications of fluctuations around zero. The function suppresses reading fluctuations below the set value and displays zero instead (or 20.9 % for an oxygen sensor).

### NOTE

- ▶ This is displayed with Japan EX specifications.
- ▶ Even when enabled, the zero suppression function will function only in measurement mode and display mode.
- ▶ All readings in the range from zero to the negative suppression value indicated in the <Zero suppression values> table are suppressed. Values from the negative suppression value to the M OVER value will be displayed, but accurate measurements cannot be achieved in this state. A fresh air adjustment should be performed. For information on M OVER values, refer to '4-2 Gas alarm setpoints'.

### <Zero suppression values>

Target gas	Combustible gas	O <sub>2</sub>	CO	H <sub>2</sub> S
Suppression value	2 - 5 %LEL	20.9 % ± 0.5 % (20.4 - 21.4 %)	2 ppm	0.3 ppm
Suppression type	Smoothing	Cut-air	Cut-off	Cut-off
Negative suppression value	-5 %LEL	-0.5 %	-25 ppm	-5.0 ppm
Negative suppression type	Cut-off	Cut-off	Cut-off	Cut-off

- 1 Press the AIR button on the user mode menu to select [ZERO.SUP], then press the MODE button.
- 2 Press the AIR button to select the sensor, then press the MODE button.  
Pressing the AIR button displays the detection target gases in sequence.
- 3 Press the AIR button to enable or disable zero suppression.  
Pressing the AIR button lets you select [On] or [OFF] for zero suppression.  
The default setting is [On].
- 4 Press the MODE button.  
[END] appears and the display returns to the screen in Step 2.
- 5 To exit setting, press the AIR button to select [ESCAPE], then press the MODE button.  
The display returns to the user mode menu.

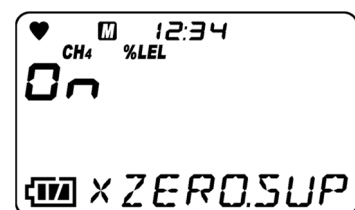
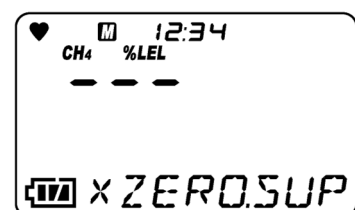
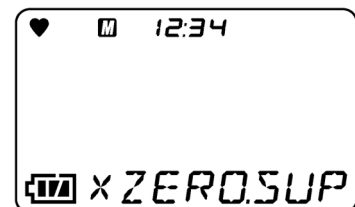

### 6-4-12 Zero follower on/off

This enables and disables the zero follower function.

The sensors used in the product may exhibit sensitivity variations when used for extended periods.

The zero follower function stabilizes the zero point by adjusting reading fluctuations at the zero point that result from extended periods of use.

<b>Combustible gas sensors</b>	The sensor output is tracked to zero the value if output fluctuations occur below the stipulated value when the power is turned on.
<b>Sensors other than combustible gas sensors</b>	The sensor output is tracked to zero the value if the sensor output repeatedly drops below zero when the power is turned on.

\* The zero follower function is enabled when the power is turned on with both combustible gas and other gases.

#### NOTE

- ▶ This is displayed with Japan EX specifications.
- ▶ The zero follower function is not enabled for oxygen sensors.
- ▶ When the zero follower function is enabled, the product will not comply with EN-60079-2-1.
- ▶ When the zero follower function is enabled, the product will not comply with JIS 8206:2020 even if the combustible gas is CH<sub>4</sub>.

- 1 **Press the AIR button on the user mode menu to select [ZERO.FLW], then press the MODE button.**

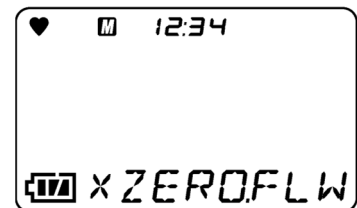

- 2 **Press the AIR button to select the sensor, then press the MODE button.**  
Pressing the AIR button displays the detection target gases other than [O<sub>2</sub>] (oxygen) in sequence.

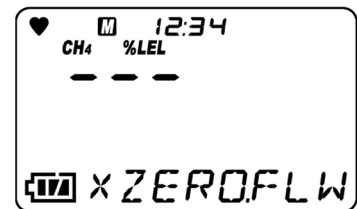

- 3 **Press the AIR button to select zero follower on or off.**  
Pressing the AIR button lets you select zero follower [On] or [OFF]. The default setting is [On] for combustible gas, carbon monoxide, and hydrogen sulfide.

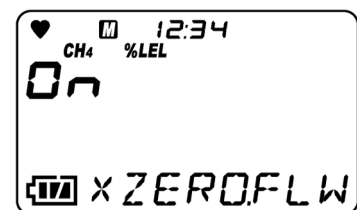

- 4 **Press the MODE button.**  
[END] appears and the display returns to the screen in Step 2.
- 5 **To exit setting, press the AIR button to select [ESCAPE], then press the MODE button.**  
The display returns to the user mode menu.

### 6-4-13 Date and time setting

The internal clock date (year, month, day) and time (hours and minutes) can be set.

- 1 Press the AIR button on the user mode menu to select [DATE], then press the MODE button.

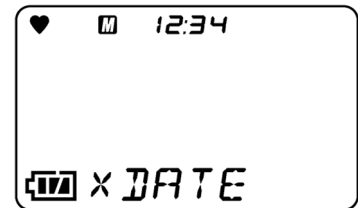

- 2 Press the AIR button to select the required setting item, then press the MODE button.

The item currently blinking can be set.

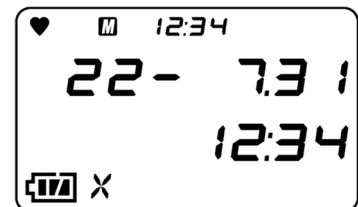

- 3 Repeat Step 2.

Set the date and time in the sequence year → month → day → hour → minute.

Press the MODE button after setting the minutes. [END] appears and the display returns to the user mode menu.

### 6-4-14 Password setting

This lets you protect access to user mode using a password. When the password setting is enabled, a password can be set as a four-digit number in the range from [0000] - [9999].

- 1 Press the AIR button on the user mode menu to select [PASS-W], then press the MODE button.

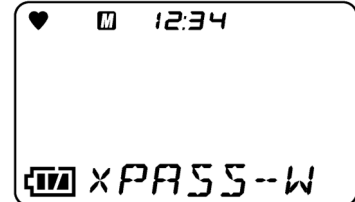

- 2 Press the AIR button to select [On], then press the MODE button.

The password input screen is displayed.

Selecting [OFF] unlocks password protection and exits the setting.

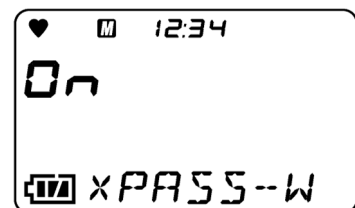

- 3 Press the AIR button to select from [0] - [9], then press the MODE button.

The number is input as the first digit of the password and the second digit blinks.

The default setting is [0000].

The password can be set in the range from [0000] - [9999].

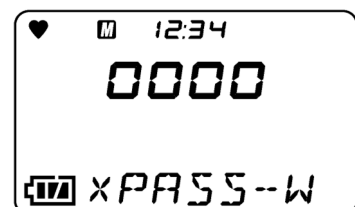

- 4 Repeat Step 3.

After entering the final digit, press the MODE button.

[END] appears and the display returns to the user mode menu.

**<Accessing user mode when password-protected>**

- 1 With the power turned off, press the AIR button and POWER button at the same time.**

Release the buttons when the buzzer blips. The password input screen is displayed.

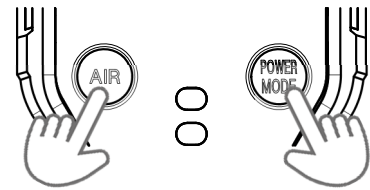

- 2 Press the AIR button to select from [0] - [9], then press the MODE button.**

The number is input as the first digit of the password and the second digit blinks.

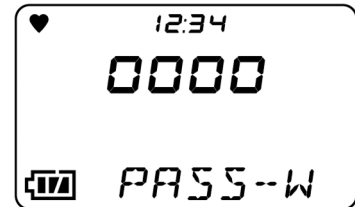

- 3 Repeat Step 2.**

The user mode menu is displayed once the final digit of the password has been entered.

If the password entered is incorrect, an error is displayed. The product switches to measurement mode as described in '5-3-2 Screen transition from powering on to measurement mode'.

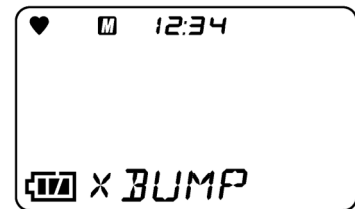

**6-4-15 ROM/SUM display**

This displays the program number and SUM value of the product. This is not normally used by the user.

- 1 Press the AIR button on the user mode menu to select [ROM/SUM], then press the MODE button.**

The following information is displayed alternately:

- [MAIN.ROM]
- [SENS.ROM]

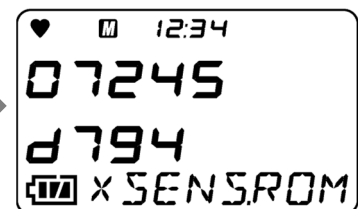
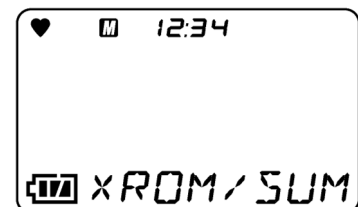
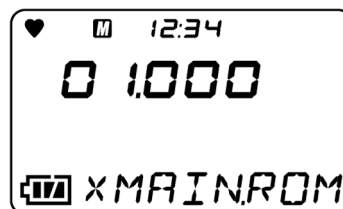

- 2 Press the MODE button.**

[END] appears and the display returns to the user mode menu.

## 7

# Maintenance

The product is an important safety and disaster prevention device. Perform product maintenance at regular intervals to ensure performance and to improve disaster prevention and safety reliability.

## 7-1 Maintenance intervals and items

The following items should be maintained regularly before using the product:

- Daily maintenance: Perform maintenance before commencing work.
- Monthly maintenance: Perform maintenance by testing the alarms once a month.
- Regular maintenance: Perform maintenance at least once a year (ideally, at least once every six months).

Maintenance item	Inspection details	Daily maintenance	Monthly maintenance	Regular maintenance
Battery level	Check to confirm that battery levels are adequate.	○	○	○
Concentration display	Check to confirm that the concentration reading is 0 (or 20.9 % for oxygen meter) by measuring fresh air. If the reading is not 0, check to confirm that no interference gases are present, then perform fresh air adjustment.	○	○	○
Main unit operation	Check the LCD display to confirm the absence of fault indication.	○	○	○
Filter	Check to confirm that the filter is not dirty.	○	○	○
Alarm test	Test the alarm and check to confirm that the alarm LED arrays, buzzer, and vibrator all operate correctly.	—	○	○
Span adjustment	Perform span adjustment using a calibration gas.	—	—	○
Gas alarm check	Check the gas alarm with a calibration gas.	—	—	○



### WARNING

- If you encounter a product abnormality, contact Riken Keiki immediately.

### NOTE

- ▶ Span adjustment requires dedicated tools and preparation of a calibration gas. Always contact Riken Keiki for span adjustment.
- ▶ The built-in sensors have finite service lives and must be replaced regularly.
- ▶ If the sensors cannot be adjusted using span adjustment, the readings are not restored after fresh air adjustment, or the readings fluctuate, the sensors are at the end of their life. Contact Riken Keiki to request checking.

### 7-1-1 Maintenance service

**Riken Keiki provides services related to regular maintenance, including span adjustment, as well as other adjustments and maintenance.**

Preparing calibration gas requires the use of dedicated tools, such as gas cylinders of the specified concentration and gas sampling bags.

Our certified service engineers have expert knowledge of the dedicated tools used for these services, along with expertise in products. Please take advantage of the Riken Keiki maintenance service to maintain safe operation of the product. The major maintenance service items are as follows. Contact Riken Keiki for more information.

#### <Main maintenance service details>

<b>Battery level check</b>	Checks battery levels.
<b>Concentration display check</b>	Checks to confirm that the concentration reading is 0 (or 20.9 % for oxygen meter) using a zero gas. Zero adjustment (air adjustment) if the reading is offset
<b>Filter check</b>	Checks the dust filter for contamination and clogging. The filter is replaced if dirty or clogged.
<b>Alarm test</b>	Tests the alarm to check to confirm that the alarm LEDs, buzzer, and vibration all operate correctly.
<b>Span adjustment</b>	Adjusts sensitivity using a calibration gas.
<b>Gas alarm check</b>	Checks the gas alarm using a calibration gas. <ul style="list-style-type: none"> <li>▪ Check alarms. (Confirm alarm activation when alarm setpoint is reached.)</li> <li>▪ Check delay time. (Check delay time until alarm activation.)</li> <li>▪ Checks the buzzer, LEDs, vibration, and concentration display. (Checks operation for each of the three-step alarms.)</li> </ul>
<b>Product cleaning and repair (visual inspection)</b>	Checks the product exterior for dirt and cleaning/repairing of visible areas Parts are replaced if cracked or damaged.
<b>Product operation check</b>	Operates the buttons to check function operations and parameters.
<b>Degraded part replacement</b>	Replaces degraded components such as sensors and filters.

## 7-2 Gas adjustment

The product can be adjusted using AUTO adjustment with preset gas concentrations in addition to fresh air adjustment.

Span adjustment requires a calibration gas. Contact Riken Keiki.



- Do not use lighter gas to check the sensitivity of the product. Constituents in lighter gas may degrade sensor performance.

### 7-2-1 Preparation for gas adjustment

#### <Required equipment/materials>

- Calibration gas
- Gas sampling bag

#### <Recommended calibration gas concentrations>

Detection target gas	Sensor model	Calibration gas	Calibration gas concentration
Combustible gas (HC)	NCR-6309	Isobutane (i-C <sub>4</sub> H <sub>10</sub> )	50 %LEL (0.9 %)
Combustible gas (CH <sub>4</sub> )	NCR-6309	Methane (CH <sub>4</sub> )	50 %LEL (2.5 %)
Hydrogen sulfide (H <sub>2</sub> S)	ESR-A1DP or ESR-A13i	Hydrogen sulfide (H <sub>2</sub> S)	25.0 ppm
Oxygen (O <sub>2</sub> )	ESR-X13P	Oxygen (O <sub>2</sub> ) nitrogen diluted	12.0 % or nitrogen
Carbon monoxide (CO)	ESR-A1DP or ESR-A13P	Carbon monoxide (CO)	50 ppm
Carbon monoxide (CO)	ESR-A1CP	Carbon monoxide (CO)	50 ppm
		Hydrogen (H <sub>2</sub> ) air diluted	500 ppm

\* Hydrogen must be adjusted in the range of 10 °C - 30 °C.

\* The same applies to bump test gas.

\* We recommend using cylinders of gas at the concentrations specified above for the calibration gas.



### <Gas supply method>

Connect the gas sampling bag as shown in the figure below to introduce gas, and wait 60 seconds after the reading increases before adjusting.

#### <When open to the atmosphere>

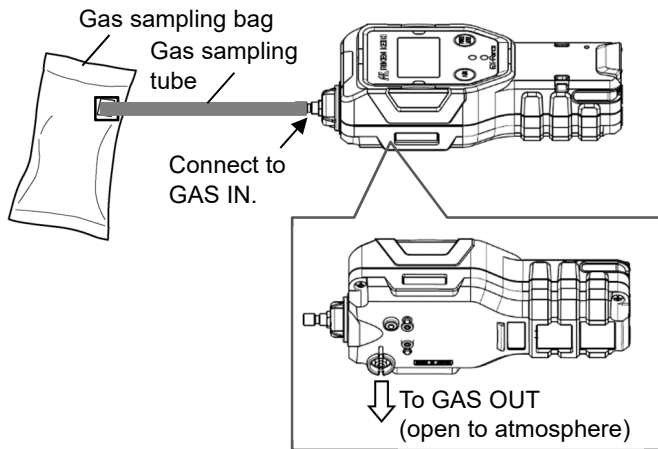

#### <When using gas recovery>

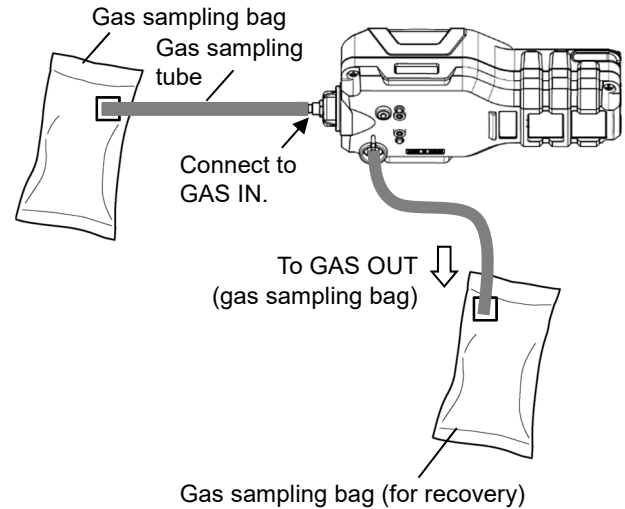

## WARNING

### About the calibration gas

- Do not use lighter gas to check the sensitivity of the product. Constituents in lighter gas may degrade sensor performance.
- The calibration gas is a hazardous gas (e.g., combustible gas, toxic gas, oxygen deficiency). Handle the gas and related jigs and tools with due care.

### Gas sampling bag

- Use different gas sampling bags for each gas type and concentration to ensure accurate adjustment.

### Gas adjustment location

- Do not perform gas adjustment in a confined space.
- Do not perform gas adjustment in locations where gases such as silicone and spray can gases are used.
- Calibrate indoors at normal temperatures with no significant fluctuations (within  $\pm 5$  °C).

### Carbon monoxide sensor (ESR-A1CP) gas adjustment

- The carbon monoxide sensor with hydrogen interference correction function (ESR-A1CP) must be adjusted separately for carbon monoxide and hydrogen.
- The carbon monoxide and hydrogen used for adjustment must each be a single gas. Adjustment can be performed using a gas mixture, but it will result in poor sensitivity adjustment and inaccurate concentration readings.
- If hydrogen sensitivity is not adjusted, carbon monoxide readings may be slightly higher or lower than the actual concentrations when measured in environments where hydrogen is also present.



## WARNING

- When feeding gas, it should either be discharged to a safe location with the GAS OUT outlet open to the atmosphere or collected using a gas sampling bag.
- Hydrogen span adjustment may become impossible if the product is used or stored for extended periods in dry environments. If [FAIL AUTO.CAL] is displayed during hydrogen span adjustment, allow the product to stand overnight in a sufficiently humid environment before repeating the gas adjustment. However, if carbon monoxide span adjustment is no longer possible, contact Riken Keiki to request sensor replacement.

## 7-2-2 Gas adjustment setting

Gas adjustment setting is configured in [GAS CAL] in user mode. The following menu displayed in [GAS CAL] allows fresh air adjustment and AUTO adjustment to be performed, as well as AUTO adjustment setting to be configured.

### <[GAS CAL] menu>

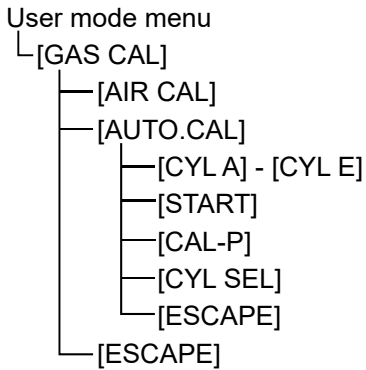

### <[GAS CAL] menu selection>

- 1 Press the AIR button on the user mode menu to select [GAS CAL], then press the MODE button.

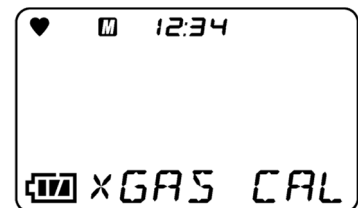

- 2 Press the AIR button to select the required setting item, then press the MODE button.

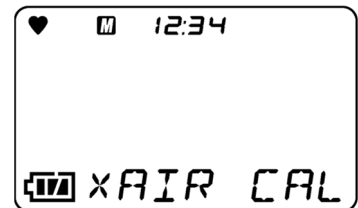

Screen notation	LCD display	Reference
[AIR CAL]		'7-2-3 Fresh air adjustment'
[AUTO.CAL]		'7-2-4 AUTO adjustment' '7-2-5 AUTO adjustment setting'

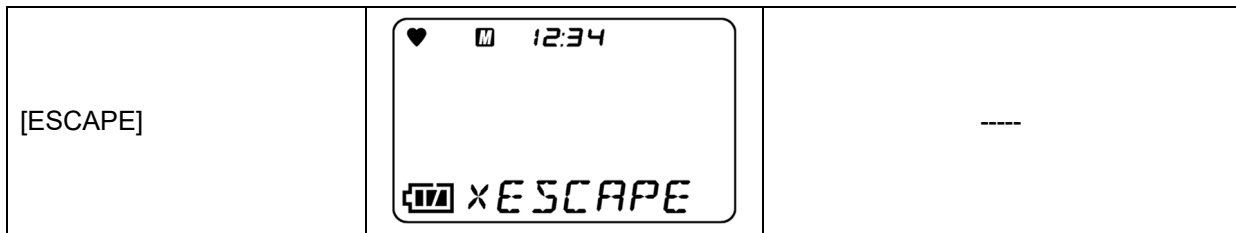

---

**NOTE**

- ▶ To exit the [GAS CAL] menu, press the AIR button to select [ESCAPE], then press the MODE button. The display returns to the user mode menu.
  - ▶ To exit the [AUTO.CAL] menu, press the AIR button to select [ESCAPE], then press the MODE button. The display returns to the [GAS CAL] menu.
  - ▶ It is possible to switch from AUTO adjustment to measurement mode. Press the AIR button on the [AUTO.CAL] menu to select [START], then press the MODE button. The product operates in the same way as at power-on and switches to measurement mode.
-

7-2-3 Fresh air adjustment

**WARNING**

- When fresh air adjustment is performed in the atmosphere, check the atmosphere for freshness before starting. The presence of interference gases will make it impossible to perform zero adjustment correctly and potentially result in hazardous conditions in the event of actual gas leaks.

**CAUTION**

- Always perform fresh air adjustment under conditions of pressure, temperature, and humidity similar to those in the operating environment and in fresh air.
- Wait for the reading to stabilize before performing fresh air adjustment.

1 Press the AIR button on the [GAS CAL] menu to select [AIR CAL], then press the MODE button.

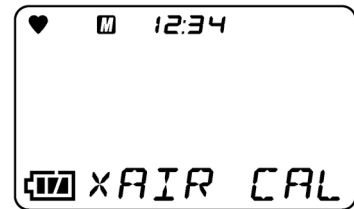

2 Hold down the AIR button.

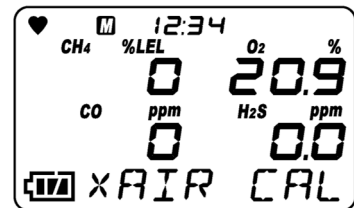

Keep the AIR button pressed for as long as the screen shown on the right is displayed.

Fresh air adjustment will not be performed if you release the button before the screen is displayed or while it is displayed.

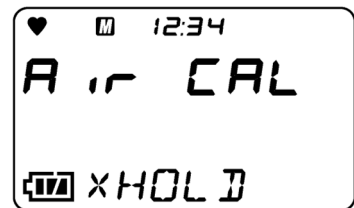

3 Release the AIR button once [RELEASE] is displayed. Fresh air adjustment is performed.



[PASS] is displayed if fresh air adjustment was successful.



The current concentration appears after fresh air adjustment and the display returns to the screen in Step 1.

[FAIL] is displayed if adjustment was unsuccessful.

[END] appears and the display returns to the screen in Step 1.

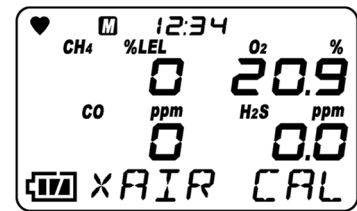

**NOTE**

- ▶ If fresh air adjustment fails, [FAIL] appears next to the measurement for the corresponding sensor together with [AIR CAL]. Press the MODE button to reset the fault alarm (adjustment failure). If a sensor fails fresh air adjustment, fresh air adjustment will not be performed, and the concentration will be calculated using the value before adjustment. For more information on resetting this fault, refer to '9 Troubleshooting'.
- ▶ Fresh air adjustment can also be performed in measurement mode. (Refer to '5-4 Fresh air adjustment'.)

**7-2-4 AUTO adjustment**

This adjusts for each gas at the specified concentration.

**NOTE**

- ▶ Fresh air adjustment must always be performed before performing AUTO adjustment.

**1 Press the AIR button on the [GAS CAL] menu to select [AUTO.CAL], then press the MODE button.**

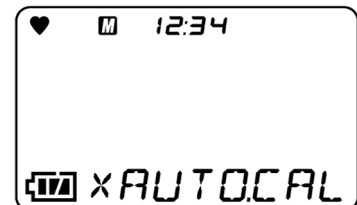

**2 Press the AIR button to select the cylinder for adjustment, then press the MODE button.**

Pressing the AIR button displays the gas type and concentration for cylinders A - E in sequence. Only those cylinders with gas types assigned are displayed. For information on the cylinder settings, refer to '<AUTO adjustment cylinder settings>' in '7-2-5 AUTO adjustment setting'.

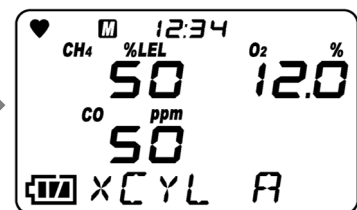
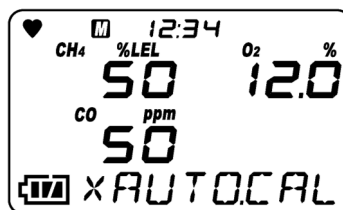

**3 Introduce the calibration gas, wait 60 seconds, then press the MODE button.**

Use a stopwatch or similar to count the time.

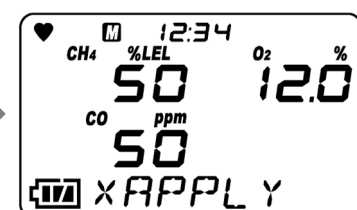
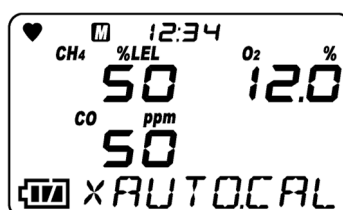

AUTO adjustment is performed.

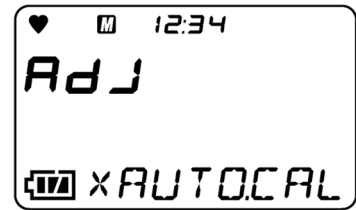

[PASS] is displayed if AUTO adjustment was successful.  
[FAIL] is displayed if adjustment was unsuccessful.

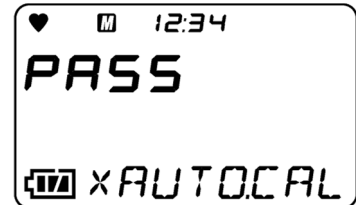

The concentration after AUTO adjustment is displayed.  
With Japan EX specifications, the concentration and sensor reserve value after AUTO adjustment are displayed after AUTO adjustment has been successfully performed.

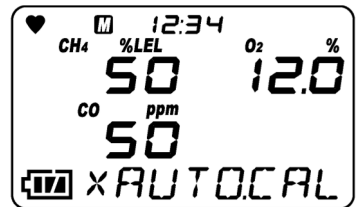

The product switches to measurement mode.

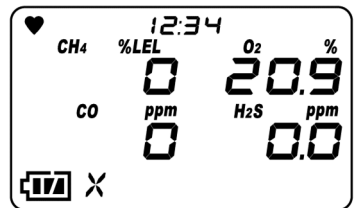

## NOTE

- ▶ The display automatically switches to measurement mode when auto adjustment is successful. The display does not switch to measurement mode, however, if multiple cylinders are set.
- ▶ To switch from auto adjustment to measurement mode, press the AIR button on the [AUTO.CAL] menu to select [START], then press the MODE button. The product operates in the same way as when the power has just been turned on and switches to measurement mode.

**WARNING**

- On models that detect combustible gases, the screen shown on the right may be displayed with the buzzer sounding and LED flashing after AUTO adjustment is performed.

If this screen is displayed, some combustible gases cannot be converted using the combustible gas conversion function. For information on the types of gases that cannot be converted, refer to '6-2-3 Combustible gas conversion setting'.

If the screen shown on the right appears, the alarm can be temporarily reset by pressing the MODE button (or after five seconds if no buttons are pressed).

Note that the screen shown on the right appears when the combustible gas sensor is placed under the poisoning effects of silicone compounds or halides. If the screen shown on the right is displayed, the conversion function can be used only for those gas types marked "O" in the "Conversion when conversion is restricted" column. To continue to use the conversion function for gas types marked "x", contact Riken Keiki.

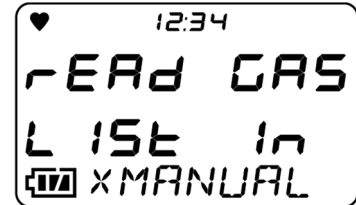

## 7-2-5 AUTO adjustment setting

This sets the AUTO adjustment cylinders and adjustment concentrations.

### <AUTO adjustment cylinder settings>

Set the gas groups (cylinders) for calibration. The cylinders can be set as A - E.

- 1 Press the AIR button on the [GAS CAL] menu to select [AUTO.CAL], then press the MODE button.

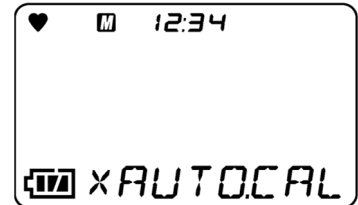

- 2 Press the AIR button to select [CYL SEL], then press the MODE button.

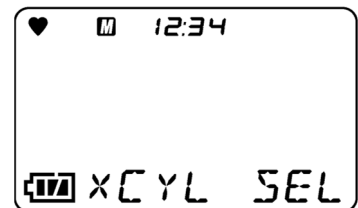

- 3 Press the AIR button to select the sensor, then press the MODE button.

Pressing the AIR button displays the detection target gases in sequence.

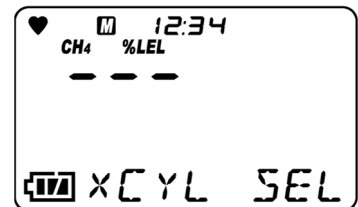

- 4 Press the AIR button to select a cylinder from A - E, then press the MODE button.

[END] appears and the display returns to the screen in Step 3.

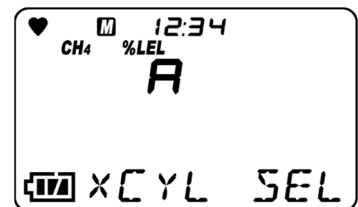

- 5 To exit setting, press the AIR button to select [ESCAPE], then press the MODE button.

The display returns to the screen in Step 2.



### <AUTO adjustment calibration gas concentration selection>

Calibration gas concentrations for AUTO adjustment can be set for each sensor.

The calibration gas concentrations can be set in one-digit units within the setting range.

### <Calibration gas concentration setting ranges>

Detection target gas	Sensor model	Calibration gas	1 digit	Lower limit	Upper limit
Combustible gas (HC)	NCR-6309	Isobutane (i-C <sub>4</sub> H <sub>10</sub> )	1 %LEL	1 %LEL	75 %LEL
Combustible gas (CH <sub>4</sub> )	NCR-6309	Methane (CH <sub>4</sub> )	1 %LEL	1 %LEL	75 %LEL
Hydrogen sulfide (H <sub>2</sub> S)	ESR-A1DP or ESR-A13i	Hydrogen sulfide (H <sub>2</sub> S)	0.1 ppm	0.5 ppm	200.0 ppm
Oxygen (O <sub>2</sub> )	ESR-X13P	Oxygen (O <sub>2</sub> )	0.1 %	0.0 %	18.0 %
Carbon monoxide (CO)	ESR-A1DP or ESR-A13P	Carbon monoxide (CO)	1 ppm	12 ppm	2,000 ppm
Carbon monoxide (CO)	ESR-A1CP	Carbon monoxide (CO)	1 ppm	12 ppm	2,000 ppm
		Hydrogen (H <sub>2</sub> ) air diluted	1 ppm	25 ppm	2,000 ppm

\* CO (-H<sub>2</sub>) adjustment should be performed using a single gas and not as a mixture of CO and H<sub>2</sub>.

\* Hydrogen must be adjusted in the range of 10 °C - 30 °C.

- 1 Press the AIR button on the [GAS CAL] menu to select [AUTO.CAL], then press the MODE button.

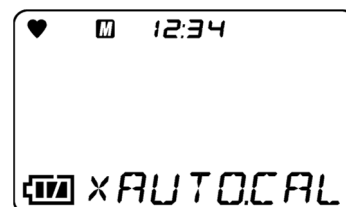

- 2 Press the AIR button to select [CAL-P], then press the MODE button.

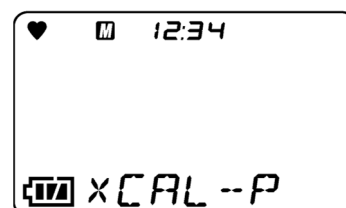

- 3 Press the AIR button to select the sensor, then press the MODE button.

Pressing the AIR button displays the detection target gases in sequence.

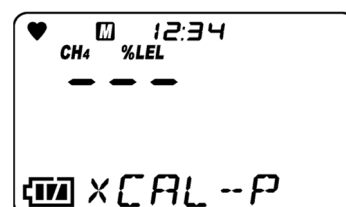

- 4 Press the AIR button to select the adjustment concentration, then press the MODE button.

[END] appears and the display returns to the screen in Step 3.

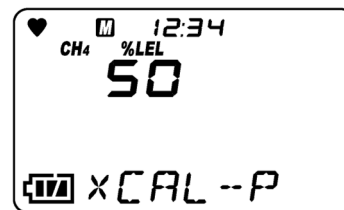

- 5 To exit setting, press the AIR button to select [ESCAPE], then press the MODE button.

The display returns to the screen in Step 2.

---

## NOTE

- ▶ It is possible to switch from AUTO adjustment to measurement mode. Press the AIR button on the [AUTO.CAL] menu to select [START], then press the MODE button. The product operates in the same way as at power-on and switches to measurement mode.
-

# 7-3 Bump test

The product includes a function for performing a bump test (function check).

## 7-3-1 Performing bump test

A bump test can be performed for gas types selected from cylinders A - E. Prepare the bump test gas in the same way as for the calibration gas. (Refer to '7-2-1 Preparation for gas adjustment'.)

- 1 Press the AIR button on the user mode menu to select [BUMP], then press the MODE button.

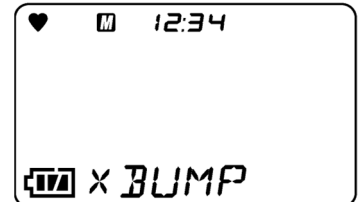

- 2 Press the AIR button to select the cylinder for the bump test, then press the MODE button.

Pressing the AIR button displays the gas type and concentration for cylinders A - E in sequence. Only those cylinders with gas types assigned are displayed. For information on the cylinder settings, refer to '<AUTO adjustment cylinder settings>' in '7-2-5 AUTO adjustment setting'.

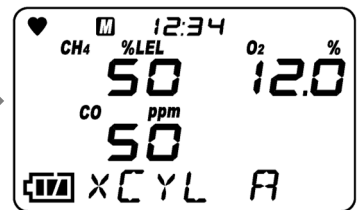
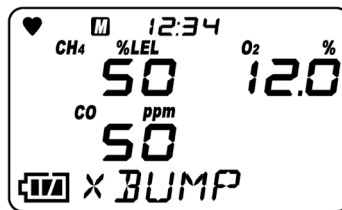

- 3 Introduce the bump test gas, then press the MODE button.

The bump test is performed.

If set to perform gas adjustment after a bump test failure, the product will automatically perform gas adjustment in the event of a bump test failure. (Refer to '6-4-4 Bump test setting'.)

After the bump test and gas adjustment are completed, the bump test results (left) and gas adjustment results (right) are displayed together with the readings at the bump test and after gas adjustment.

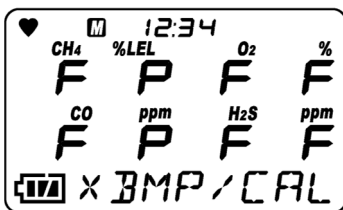

Bump test (gas adjustment) results  
[P]: Passed, [F]: Failed

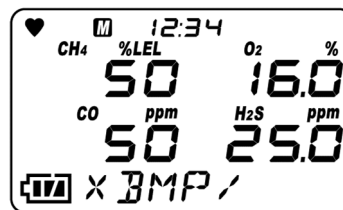

Readings at bump test

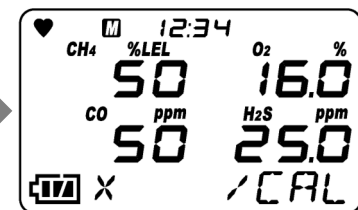

Readings after gas adjustment  
(Displayed only if gas adjustment was performed)

- 4 Press the MODE button.

[END] is displayed, and the product switches to measurement mode.

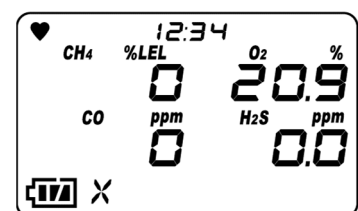

**NOTE**

- ▶ The display automatically switches to measurement mode when the bump test is successful. The display does not switch to measurement mode, however, if multiple cylinders are set.
- ▶ To switch from bump test to measurement mode, press the AIR button on the BUMP screen to select [START], then press the MODE button. The product operates in the same way as when the power has just been turned on and switches to measurement mode.

**CAUTION**

On models that detect combustible gases, the screen shown on the right may be displayed with the buzzer sounding and LED flashing following gas adjustment after a bump test failed.

If this screen is displayed, some combustible gases cannot be converted using the combustible gas conversion function. For information on the types of gases that cannot be converted, refer to '6-2-3 Combustible gas conversion setting'.

If the screen shown on the right appears, the alarm can be temporarily reset by pressing the MODE button (or after five seconds if no buttons are pressed).

Note that the screen shown on the right appears when the combustible gas sensor is placed under the poisoning effects of silicone compounds or halides. If the screen shown on the right is displayed, the conversion function can be used only for those gas types marked "○" in the "Conversion when conversion is restricted" column. To continue to use the conversion function for gas types marked "×", contact Riken Keiki.

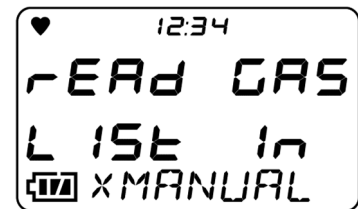

## 7-4 Cleaning procedure

Clean the product if it becomes excessively dirty.

Be sure to turn off the power before cleaning, and wipe clean using a rag or cloth soaked in water and firmly wrung out. Do not clean using water, organic solvents or commercially available cleaners, as these may cause the product to malfunction.



- When wiping the product clean, do not splash water on it or use organic solvents like alcohol and benzene or commercially available cleaners. These may discolor or damage the surface of the product, or cause the sensor to malfunction.

### NOTE

- ▶ Water may remain in the buzzer sound opening or grooves after the product has got wet. Remove any moisture as follows:
  - ① Wipe off any moisture on the product using a dry towel or cloth.
  - ② Hold the product firmly and shake about 10 times with the buzzer sound opening facing downward.
  - ③ Use a towel or cloth to wipe up all moisture drained from the interior.
  - ④ Place the product on a dry towel or cloth and allow to stand at room temperature.

## 7-5 Parts replacement

### 7-5-1 Periodic replacement parts

The consumable parts of the product are listed below. Consumable parts should be replaced using the recommended replacement intervals as a guide.

#### <Recommended replacement parts list>

Name	Recommended check interval	Recommended replacement interval	Quantity	Remarks
Combustible gas sensor (NCR-6309)	6 months	3 years	×1	*
O <sub>2</sub> sensor (ESR-X13P)	6 months	3 years	×1	*
CO/H <sub>2</sub> S sensor (ESR-A1DP)	6 months	3 years	×1	*
CO sensor (ESR-A13P)	6 months	3 years	×1	*
CO sensor (ESR-A1CP)	6 months	3 years	×1	*
H <sub>2</sub> S sensor (ESR-A13i)	6 months	3 years	×1	*
Pump unit (RP-12)	6 months	1 - 2 years	×1	*
Dust filter	Before and after use	6 months or when contaminated	×1	Part No.: 4777 4213 40
Interference gas removal filter	3 months	6 months	×1	For combustible gas sensor (NCR-6309) Part No.: 4777 9315 90 (set of 5)
Interference gas removal filter	3 months	6 months	×1	For CO/H <sub>2</sub> S sensor (ESR-A1DP) Part No.: 4777 9314 10
Interference gas removal filter	3 months	6 months	×1	CO sensor (ESR-A1CP, ESR-A13P) Part No.: 4777 9316 60 (set of 5)
Humidity control filter	3 months	6 months	×1	For H <sub>2</sub> S sensor (ESR-A13i) Part No.: 4777 9317 30 (set of 5)
Rubber seals	-	3 - 6 years	1 set	*
Battery	-	Approx. 500 charging/discharging cycles	×1	*

\* A functional check by a qualified service engineer is required after replacement. To ensure safety and the stable operation of the product, request checking by a qualified service engineer. Contact Riken Keiki to request checking.

#### NOTE

- ▶ The above replacement intervals are guidelines only. Replacement intervals may vary depending on actual operating conditions. These intervals do not constitute warranty periods. Replacement intervals may vary depending on the results of regular maintenance.

## 7-5-2 Filter replacement

The dust filter and interference gas removal filters are consumables. Check the extent of contamination and replace them regularly.

### <Dust filter replacement procedure>

- 1 **Rotate the filter case 90 degrees counterclockwise to remove from the main unit.**

- 2 **Turn the main unit upside down to remove the dust filter.**

The product contains two identical dust filters (primary and secondary filters) sandwiching a metal mesh.

Turn the main unit upside down and allow the two dust filters and metal mesh to drop out onto your hand.

If the dust filters do not readily come out, remove with tweezers.

- 3 **Replace with new dust filters.**

Sandwich the metal mesh between the two new dust filters.

- 4 **Rotate the filter case 90 degrees clockwise to reattach to the main unit.**

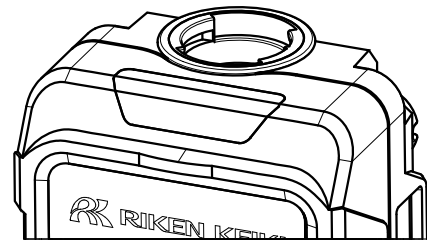
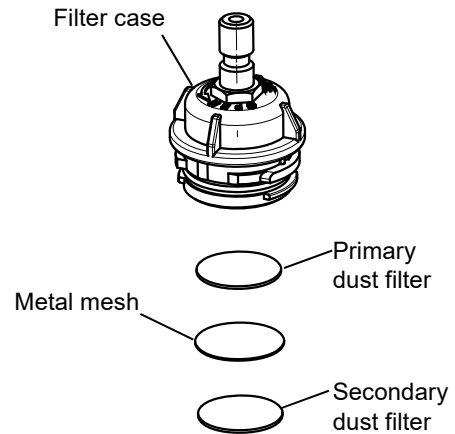

## WARNING

- Install the dust filter correctly. Product performance cannot be guaranteed if it is misaligned.
- Replace the dust filter every six months. Replace the filter whenever it becomes contaminated even if it is less than six months.
- When replacing the dust filter, follow the procedure described above, tighten the filter case securely, and make sure that it is securely attached.  
If the filter case is securely attached, foreign matter may get inside the product. Foreign matter may also get in if even minute particles are caught between the contact surfaces.
- Do not damage the rubber seals.
- To maintain performance, we recommend replacing all rubber seals every 3 - 6 years, regardless of condition.
- Be sure to use only dust filters specifically intended for use with the product (GX-Force). Use of non-approved parts may adversely affect gas detection performance and allow water to get inside the product.

**<Interference gas removal filter replacement procedure>**

- 1 Loosen the four screws on the rear of the main unit.
- 2 Remove the lower case, rubber seals, and interference gas removal filters in that sequence, then replace with new interference gas removal filters.
- 3 Reseat the rubber seals in their original positions.
- 4 Retighten the four screws on the rear of the main unit diagonally.

\* Tightening torque: 25.5 N·cm ± 3 N·cm.

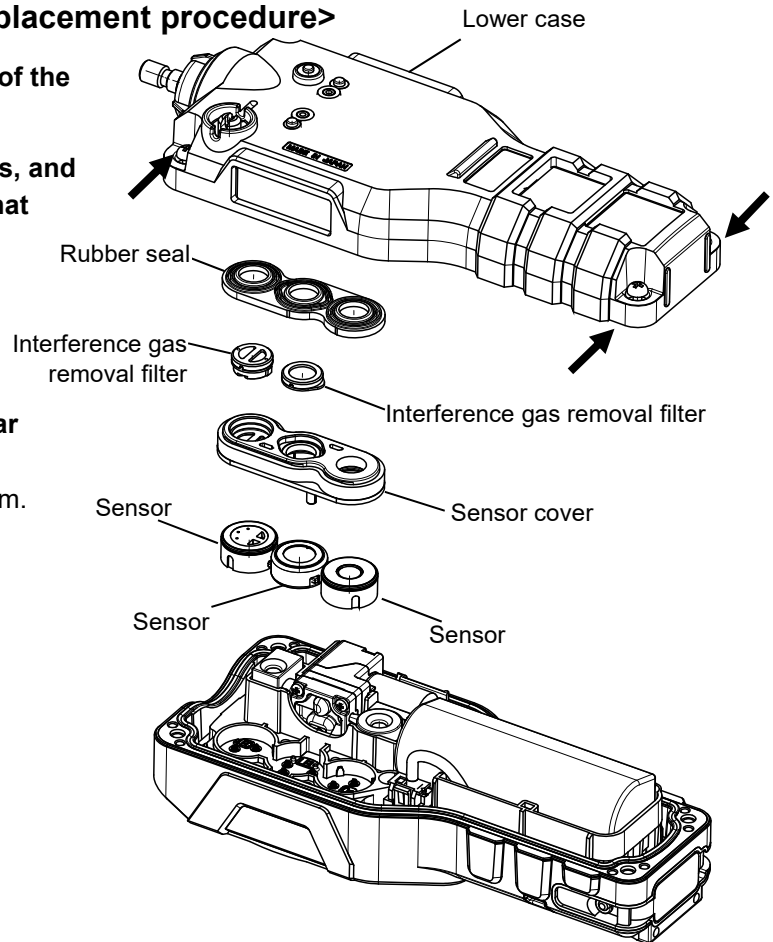

## **WARNING**

- Install the individual interference gas removal filters correctly. If they are misaligned, gas may leak, preventing correct detection.
- Replace the interference gas removal filters every six months. Replace the filter whenever it becomes contaminated even if it is less than six months.
- When replacing individual interference gas removal filters, follow the procedure described above, and tighten the screws securely. If the screws are loose, foreign matter may get inside the product. Foreign matter may also get in if even minute particles are caught between the contact surfaces.
- Do not damage the rubber seals.
- To maintain performance, we recommend replacing all rubber seals every 3 - 6 years, regardless of condition.
- Be sure to use only interference gas removal filters specifically intended for use with the product (GX-Force). Use of non-approved parts may adversely affect gas detection performance and allow water to get inside the product.
- Use only the dedicated interference gas removal filter for each particular sensor. Otherwise gas may not be detected correctly.



---

## 8

---

# Storage and Disposal

## 8-1 Procedures for storage or when not in use for extended periods

The product must be stored in the following environment:

- At normal temperature, humidity, and pressure in a location not exposed to direct sunlight
- In a location free of gases, solvents, and vapors

Store the product in its shipping carton if this has been retained.

If the shipping carton is not available, store away from dust and dirt.

Replacement parts should be used in accordance with the descriptions on the nameplates affixed to the parts.



### CAUTION

- Even if you do not intend to use the product for extended periods, turn the power on at least once every six months to check pump suction (by running the product for approximately three minutes). Grease inside the pump motor may solidify and prevent operation if the product is not operated for extended periods.

---

### NOTE

- ▶ If the product is not to be used for extended periods, we recommend storing after the battery is discharged until the battery level icon shows one bar. Storing while fully charged may reduce battery life and accelerate battery deterioration.

---

## 8-2 Procedures for use after storage

Perform gas adjustment if the product is used again after a period in storage.



### CAUTION

- Contact Riken Keiki to request readjustment and gas adjustment.
  - If there is a temperature difference of 15 °C or more between the storage and usage locations, allow the product to stand and acclimatize for about 10 minutes in an environment similar to the usage location before turning on the power and performing fresh air adjustment in fresh air.
-

## 8-3 Product disposal

Dispose of the product as industrial waste (incombustible) in accordance with local regulations.



### WARNING

- Never attempt to disassemble electrochemical type sensors, as they contain electrolyte. Electrolyte may cause inflammation if it comes into contact with the skin, and may cause blindness if it comes into contact with the eyes. Contact with clothing may result in discoloration or damage to the fabric. If contact occurs, rinse the area immediately with plenty of water.
- Dispose of batteries in accordance with procedures specified by local authorities.

### <Disposal in EU member states>

When disposing of the product in an EU member state, dispose of the battery separately.

The battery removed from the battery compartment must be handled in accordance with waste sorting and collection or recycling systems stipulated by the regulations of EU member states.

### NOTE

#### Crossed-out recycle dustbin mark

- ▶ This pictogram is affixed to products which contain batteries that fall under EU Battery Directive 2006/66/EC. Such batteries need to be disposed of as specified by the latest directive. This pictogram also means batteries must be separated from ordinary waste and disposed of appropriately.



## 9

# Troubleshooting

This troubleshooting chapter does not cover the causes of all possible product malfunctions. It provides brief explanations to assist in determining the causes of common problems.

If you encounter symptoms not addressed here or if problems persist even after taking corrective action, contact Riken Keiki.

## 9-1 Product abnormalities

Symptom Screen display	Cause	Action
The power cannot be turned on.	The battery is depleted.	Charge the battery in a safe location at an ambient temperature between +10 °C and +40 °C.
	The POWER button was pressed for too short or too long a time.	To turn on the power, hold down the POWER button until the buzzer blips, then release the button.
Abnormal operation	Effects of sudden static electricity noise, etc.	Turn off the power, then turn it back on again.
Low battery voltage alarm indication [FAIL BATTERY]	The battery level is low.	Turn off the power, and charge the battery in a safe location at an ambient temperature between +10 °C and +40 °C.
The power turns off immediately when it is turned on. [TURN OFF]	The battery level is low.	Turn off the power, and charge the battery in a safe location at an ambient temperature between +10 °C and +40 °C.
Fresh air adjustment is not possible. [FAIL AIR CAL]	Fresh air is not being supplied to the product.	Provide fresh air.
	The sensor sensitivity has degraded.	Contact Riken Keiki to request sensor replacement.
Bump test is not possible.	The bump test gas concentration setting differs from the concentration of the bump test gas supplied.	Check to confirm that the bump test gas concentration setting matches the concentration of the bump test gas supplied.
	The sensor sensitivity has degraded.	Contact Riken Keiki to request sensor replacement.

Symptom Screen display	Cause	Action
Span adjustment is not possible. [FAIL AUTO.CAL]	The calibration gas concentration setting differs from the concentration of the calibration gas supplied.	Check to confirm that the calibration gas concentration setting matches the concentration of the calibration gas supplied.
	Low reading due to dry conditions. (ESR-A1CP H2 only)	Allow the product to stand overnight in a sufficiently humid environment before repeating the gas adjustment.
	The sensor sensitivity has degraded.	Contact Riken Keiki to request sensor replacement.
A sensor abnormality is indicated in measurement mode. [FAIL SENSOR]	The sensor sensitivity has degraded.	Contact Riken Keiki to request sensor replacement. (If [FAIL] appears in place of a measured value when the power is turned on, press the MODE button to reset the alarm. The gas sensors other than the faulty sensor can still be used.)
System abnormality [FAIL SYSTEM]	A circuit abnormality occurred in the main unit.	Contact Riken Keiki for repair.
Error No. 000	Internal ROM abnormality	
Error No. 010	Internal RAM abnormality	
Error No. 021	Internal FRAM abnormality	
Error No. 031	FLASH abnormality	
Error No. 080	Circuit voltage abnormality	
Error No. 081	PCB abnormality	
Error No. 082	Temperature sensor abnormality	
Clock abnormality [FAIL CLOCK]	Internal clock abnormality	Set the date and time. (Refer to '6-4-13 Date and time setting'.) If this symptom occurs frequently, the internal clock may be faulty and must be replaced. Contact Riken Keiki.
Pump abnormality [FAIL PUMP]	Pump abnormality	The pump must be replaced. Contact Riken Keiki for repair.
Low flow rate abnormality [FAIL FLOW]	Flow passage blockage	Check to confirm that there is no dust or moisture condensation inside the flow paths.
	Clogged dust filter	Replace the dust filter.
Cannot access user mode.	Forgot user mode password.	Contact Riken Keiki.
The charge LED flashes alternately green and orange.	The temperature is outside the allowable charging temperature range.	Charge at an ambient temperature between +10 °C and +40 °C.
Maintenance notification display [M-LIMIT]	Notification that the preset maintenance notification date has passed (Japan EX specifications only)	The AIR button can be pressed to proceed to measurement mode after the maintenance notification display, but contact Riken Keiki to request maintenance. * With standard settings

Symptom Screen display	Cause	Action
Adjustment expiration display [CAL-LMT]	Notification that the set adjustment expiration date has passed (ATEX/IECEX specifications only)	Press the MODE button to proceed to AUTO adjustment after the adjustment expiration display. The AIR button can be pressed to switch to measurement mode, but either perform gas adjustment yourself or contact Riken Keiki to request maintenance. * When the operation setting after adjustment expiration is set to the default setting
Bump test expiration display [BMP-LMT]	Notification that the set bump test expiration date has passed	Press the MODE button to proceed to bump test after the bump test expiration display. The AIR button can be pressed to proceed to measurement mode, but bump test should be performed. * When the operation setting after bump test expiration is set to the default setting

## 9-2 Reading abnormalities

Symptom	Cause	Action
The reading rises (or drops) and remains unchanged.	Sensor drift	Perform fresh air adjustment.
	Presence of interference gases	It is difficult to completely eliminate the effects of interference gases. Contact Riken Keiki for information on countermeasures, such as removal filters.
	Slow leakage	They may be a very small leakage (slow leakage) of the detection target gas. Leaving this unresolved may lead to dangerous situations. Take the same action as for gas alarms.
	Environmental fluctuations	Perform fresh air adjustment.
A gas alarm is triggered even though there is no problem in the measuring environment.	Presence of interference gases	It is difficult to completely eliminate the effects of interference gases. Contact Riken Keiki for information on countermeasures, such as interference gas removal filters.
	Effects of noise	Turn off the power once, and then turn it back on again (restart). If similar symptoms recur frequently, take appropriate measures to address the noise source.
Slow response	Clogged dust filter	Replace the dust filter.
	The sensor sensitivity has degraded.	Contact Riken Keiki to request sensor replacement.

## 10

# Product Specifications

## 10-1 Specifications list

### 10-1-1 Common specifications

<b>Model</b>	GX-Force
<b>Sampling method</b>	Suction type
<b>Suction flow rate</b>	Minimum 0.35 L/min <sup>*1</sup> (open flow rate)
<b>Display</b>	LCD digital (7-segment + 14-segment + icons)
<b>Display items</b>	Clock, battery level icon, operating status icon, pump operating status icon
<b>Volume</b>	Approx. 90 dB (mean value at 30 cm)
<b>Gas alarm pattern</b>	Lamp flashing, continuous modulating buzzer sounding, gas concentration display blinking, vibration
<b>Gas alarm reset operation</b>	Self-latching
<b>Fault alarm/ self-diagnosis</b>	System abnormality, clock abnormality, sensor abnormality, battery voltage drop, adjustment failure, pump abnormality, low flow rate abnormality
<b>Fault alarm pattern</b>	Lamp flashing, intermittent buzzer sounding, detail display
<b>Fault alarm reset operation</b>	Self-latching
<b>Communication specifications (for data logger)</b>	USB 2.0 (Connector: Type-C)
<b>Power source</b>	Lithium ion battery
<b>Continuous operating time</b>	Approx. 30 hours (25 °C, fully charged, no alarm, no lighting)
<b>Maximum power consumption</b>	1.08 W (3.6 V, 300 mA)
<b>Operating temperature range</b>	Temporary use environment (About 15 minutes): -40 °C - +60 °C (no sudden changes) *2 Continuous use environment: -20 °C - +50 °C (no sudden changes)
<b>Operating humidity range</b>	Temporary use environment (About 15 minutes): 0 %RH - 95 %RH (no condensation) Continuous use environment: 10 %RH - 90 %RH (no condensation)
<b>Operating pressure range</b>	80 kPa - 120 kPa (80 kPa - 110 kPa for explosion-proof range)
<b>Construction</b>	Dustproof, waterproof construction equivalent to IP67 <sup>*3</sup> , drop resistant to 3 m
<b>Explosion-proof construction</b>	Intrinsically safe explosion-proof construction, flame-proof enclosure

<b>Explosion-proof class</b>	Explosion-proof electrical equipment type certified (Japan EX): Ex da ia IIC T4 Ga ATEX: II 1 G Ex da ia IIC T4 Ga IECEX: Ex da ia IIC T4 Ga
<b>External dimensions</b>	Approx. 64 mm (W) × 173 mm (H) × 47 mm (D) (excluding projections)
<b>Weight</b>	Approx. 300 g

\*1 Use only the supplied dedicated accessories.

\*2 Explosion-proof performance is maintained within the range of -20 °C - +60 °C.  
Use within this range to ensure explosion-proof performance.

\*3 The IP rating does not guarantee that the product is capable of detecting gas during or after exposure to ingress conditions.

If the product has been exposed to ingress conditions, refer to '5-2 Preparations for startup' and check to confirm that the product can be used normally.



10-1-2 Individual sensor specifications

<b>Item</b>	<b>Detection target gas</b>	Combustible gas
		Methane (CH <sub>4</sub> ) or isobutane (i-C <sub>4</sub> H <sub>10</sub> ) <sup>*1</sup>
<b>Sensor model</b>		NCR-6309
<b>Detection principle</b>		New ceramic type (catalytic type)
<b>Detection range</b>		0 - 100 %LEL
<b>Resolution</b>		1 %LEL
<b>Alarm setpoints (Japan EX spec.)</b>		1st alarm: 10 %LEL 2nd alarm: 50 %LEL 3rd alarm: 50 %LEL OVER alarm: 100 %LEL
<b>Alarm setpoints (ATEX/IECEX spec.)</b>		1st alarm: 10 %LEL 2nd alarm: 25 %LEL 3rd alarm: 50 %LEL OVER alarm: 100 %LEL
<b>Response time (T90)<sup>*2</sup></b>		Methane: Within 30 seconds, Isobutane: Within 40 seconds
<b>Applicable JIS standards</b>		JIS T 8206:2020 <sup>*3</sup>

\*1 CH<sub>4</sub> or i-C<sub>4</sub>H<sub>10</sub> (HC) is set before shipping. (Specify when ordering.)

\*2 Test conditions: Response time with no sampling probe, normal temperature and humidity, and gas introduction at 0 seconds

\*3 Detection target gas: Compliant only for methane (CH<sub>4</sub>)

Item	Detection target gas	Oxygen (O <sub>2</sub> )	Carbon monoxide (CO)	Hydrogen sulfide (H <sub>2</sub> S)
<b>Sensor Model</b>		ESR-X13P	ESR-A1DP	
<b>Detection principle</b>		Electrochemical type		
<b>Display range(Japan EX spec.)</b>		0.0 - 40.0 %	0 - 2,000 ppm	0.0 - 200.0 ppm
<b>Detection range(Japan EX spec.)</b>		0.0 - 25.0 %	0 - 500 ppm	0.0 - 30.0 ppm
<b>Display range (ATEX/IECEX spec.)</b>		0.0 - 40.0 %	0 - 2,000 ppm	0.0 - 200.0 ppm
<b>Detection range (ATEX/IECEX spec.)</b>		0 - 25.0 %	0 - 500 ppm	0 - 100.0 ppm
<b>Resolution</b>		0.1 %	1 ppm	0.1 ppm
<b>Alarm setpoints (Japan EX spec.)</b>		L: 19.5 % LL: 18.0 % H: 25.0 % OVER alarm: 40.0 %	1st alarm: 25 ppm 2nd alarm: 50 ppm 3rd alarm: 50 ppm TWA alarm: 25 ppm STEL alarm: 200 ppm OVER alarm 2,000 ppm	1st alarm: 1.0 ppm 2nd alarm: 10.0 ppm 3rd alarm: 10.0 ppm TWA alarm: 1.0 ppm STEL alarm: 5.0 ppm OVER alarm: 200.0 ppm
<b>Alarm setpoints (ATEX/IECEX spec.)</b>		L: 19.5 % LL: 18.0 % H: 23.5 % OVER alarm: 40.0 %	1st alarm: 25 ppm 2nd alarm 50 ppm 3rd alarm: 1,200 ppm TWA alarm: 25 ppm STEL alarm: 200 ppm OVER alarm: 2,000 ppm	1st alarm: 5.0 ppm 2nd alarm: 30.0 ppm 3rd alarm: 100.0 ppm TWA alarm: 1.0 ppm STEL alarm: 5.0 ppm OVER alarm: 200.0 ppm
<b>Response time (T90)<sup>*4</sup></b>		Within 20 seconds	Within 30 seconds	Within 30 seconds
<b>Applicable JIS standards</b>		JIS T 8201:2010	-	JIS T 8205:2018

\*4 Test conditions: Response time with no sampling probe, normal temperature and humidity, and gas introduction at 0 seconds

Item	Detection target gas	Carbon monoxide (CO)	Carbon monoxide (CO)*5	Hydrogen sulfide (H <sub>2</sub> S)
<b>Sensor Model</b>		ESR-A13P	ESR-A1CP	ESR-A13i
<b>Detection principle</b>		Electrochemical type		
<b>Display range (Japan EX spec.)</b>		0 - 2,000 ppm	0 - 2,000 ppm	0.0 - 200.0 ppm
<b>Detection range (Japan EX spec.)</b>		0 - 500 ppm	0 - 500 ppm	0.0 - 30.0 ppm
<b>Display range (ATEX/IECEx spec.)</b>		0 - 2,000 ppm	0 - 2,000 ppm	0.0 - 200.0 ppm
<b>Detection range (ATEX/IECEx spec.)</b>		0 - 500 ppm	0 - 500 ppm	0 - 100.0 ppm
<b>Resolution</b>		1 ppm	1 ppm	0.1 ppm
<b>Alarm setpoints (Japan EX spec.)</b>		1st alarm: 25 ppm 2nd alarm: 50 ppm 3rd alarm: 50 ppm TWA alarm: 25 ppm STEL alarm: 200 ppm OVER alarm 2,000 ppm	1st alarm: 25 ppm 2nd alarm: 50 ppm 3rd alarm: 50 ppm TWA alarm: 25 ppm STEL alarm: 200 ppm OVER alarm 2,000 ppm	1st alarm: 1.0 ppm 2nd alarm: 10.0 ppm 3rd alarm: 10.0 ppm TWA alarm: 1.0 ppm STEL alarm: 5.0 ppm OVER alarm: 200.0 ppm
<b>Alarm setpoints (ATEX/IECEx spec.)</b>		1st alarm: 25 ppm 2nd alarm 50 ppm 3rd alarm: 1,200 ppm TWA alarm: 25 ppm STEL alarm: 200 ppm OVER alarm: 2,000 ppm	1st alarm: 25 ppm 2nd alarm 50 ppm 3rd alarm: 1,200 ppm TWA alarm: 25 ppm STEL alarm: 200 ppm OVER alarm: 2,000 ppm	1st alarm: 5.0 ppm 2nd alarm: 30.0 ppm 3rd alarm: 100.0 ppm TWA alarm: 1.0 ppm STEL alarm: 5.0 ppm OVER alarm: 200.0 ppm
<b>Response time (T<sub>90</sub>)*4</b>		Within 30 seconds	Within 30 seconds	Within 30 seconds
<b>Applicable JIS standards</b>		-	-	JIS T 8205:2018

\*5 The carbon monoxide sensor (ESR-A1CP) includes a correction function to reduce interference due to hydrogen. This function works for hydrogen concentrations up to 2,000 ppm. (However, if used in an environment exceeding 40°C for more than 15 minutes, it may be affected by hydrogen interference and may indicate a higher carbon monoxide concentration than actual.)

## 10-2 Accessory list

### <Accessories (Japan EX specification)>

Part name	Part No.
AC adapter	2594 1342 30
Tapered nozzle	4126 4948 20
Hand strap	0888 0605 90

\* The above accessories are not included with ATEX/IECEx specifications.

### <Optional accessories>

Part name	Part No.
AC adapter	2594 1342 30
Tapered nozzle	4126 4948 20
Hand strap	0888 0605 90
Belt clip (with attachment screw)	4711 9954 30
Filter unit set (for ESR-A1DP), set of 5	4777 9314 10
Filter unit set (for NCR-6309), set of 5	4777 9315 90
Filter unit set (for ESR-A1CP, ESR-A13P), set of 5	4777 9316 60
Filter unit set (for ESR- A13i), set of 5	4777 9317 30
Protective film, set of 5	4777 9296 50
Leather case	4777 4616 10
Gas sampling rod	0904 0275 00
Gas sampling tube	0914 0100 00
USB cable	2440 2728 90
Two-stage sampling rod	4383 0730 80
Float-type gas collector	4384 0430 60
Filter (Teflon), set of 10	4181 9573 10
Filter (metal mesh), set of 10	4181 9574 90
Data logger management program (Japan EX specifications)	9812 0010 10
Data logger management program (ATEX/IECEx specifications)	9812 0020 10

## 11

# Appendix

## 11-1 Data logger function

The product is equipped with a data logger function that records measurement results and events such as gas alarms, fault alarms, and gas adjustment.

### NOTE

- ▶ The data logger management program (sold separately) is required to check data recorded using the data logger function. Contact Riken Keiki for more information.

The data logger provides the following five functions:

### (1) Interval trend

Records the changes in measured concentration from when the power is turned on until it is turned off. For combustible gases, carbon monoxide, and hydrogen sulfide, the average value, PEAK value, and PEAK value detection time are recorded; for oxygen, the average value, minimum value, minimum value detection time, maximum value, and maximum value detection time are recorded.

The 3,600 most recent data items are recorded.

If the number of items exceeds 3,600, the oldest data will be overwritten by the latest data.

If overwriting is disabled, recording stops when 3,600 is exceeded.

If 3,600 items are recorded for a single measurement, the oldest data will not be overwritten, and recording will stop even if overwriting is enabled.

\* However, if the maximum recording time is exceeded, the oldest data will be deleted before reaching 3,600.

The maximum recording times corresponding to different intervals are as follows:

Interval	10 seconds	20 seconds	30 seconds	1 minute	3 minutes	5 minutes	10 minutes
Maximum recording time	10 hours	20 hours	30 hours	60 hours	180 hours	300 hours	600 hours

\* The default setting for interval is five minutes.

The interval can be set using the data logger management program (sold separately).

### (2) Alarm trend

When an alarm is triggered, this function records the changes in measured concentration for 30 minutes before and after the alarm occurred (one hour in total).

Alarm trend records PEAK values (minimum values for oxygen) over 5-second periods at 5-second intervals.

The eight most recent data items are recorded.

If the number of items exceeds eight, the oldest data will be overwritten by the latest data.

### (3) Alarm event

Records alarm occurrences as events.

This function records the time the alarm was triggered, the measurement target gas, and the type of alarm event.

The 100 most recent events are recorded.

If the number of events exceeds 100, the oldest data will be overwritten by the latest data.

**(4) Trouble event**

Records fault alarm occurrences as events.

This function records the time when the fault alarm was triggered, the measurement target gas, device information, and the type of trouble event.

The 100 most recent events are recorded.

If the number of events exceeds 100, the oldest data will be overwritten by the latest data.

**(5) Adjustment history**

Records data when adjustment is performed.

The adjustment history records adjustment time, concentration values before and after adjustment, and adjustment errors.

The 100 most recent adjustment history data items are recorded.

If the number of calibrations exceeds 100, the oldest data will be overwritten by the latest data.

**NOTE**

- ▶ If a USB connection is detected while the date, battery level, or alarm pattern is displayed after the power is turned on, the display switches to communication mode. Communication mode can also be selected by pressing the AIR and MODE buttons together while the date, battery level, or alarm pattern is displayed during startup.
- ▶ A fault alarm will be triggered if no communication connection can be confirmed for a preset duration in communication mode. If this occurs, either repeat the communication connection or turn off the power for the product.

## 11-2 Methane gas sensitivity and response when using supplied or optional sampling probes

The methane gas sensitivity and response will be as follows when using the supplied or optional sampling probes.

The test conditions for response time are normal temperature and humidity and gas introduction at 0 seconds.

Accessories	Part No.	Reading* <sup>1</sup>	Response time (T90)* <sup>1</sup>
No sampling probe	-	50 %LEL	Within 30 seconds
Tapered nozzle	4126 4948 20	50 %LEL	Within 30 seconds
Gas sampling rod and gas sampling tube	0904 0275 00 0914 0100 00	50 %LEL	Within 30 seconds
Two-stage sampling rod	4383 0730 80	50 %LEL	Within 30 seconds
Float-type gas collector	4384 0430 60	50 %LEL	Within 80 seconds

\*1 Stable value (representative value) with 50 %LEL methane introduced

## 11-3 100 %LEL = ppm conversion list

The following table shows the standard conversion for 100 %LEL and ppm.

The 100 %LEL values are standard values for both Japan EX and ATEX/IECEx specifications.

		Standard	IEC	ISO
Methane	CH <sub>4</sub>	50,000 ppm <sup>*2</sup>	44,000 ppm	44,000 ppm
Isobutane	i-C <sub>4</sub> H <sub>10</sub>	18,000 ppm <sup>*3</sup>	13,000 ppm	15,000 ppm
Hydrogen	H <sub>2</sub>	40,000 ppm <sup>*2</sup>	40,000 ppm	40,000 ppm
Methanol	CH <sub>3</sub> OH	55,000 ppm <sup>*1</sup>	60,000 ppm	60,000 ppm
Acetylene	C <sub>2</sub> H <sub>2</sub>	15,000 ppm <sup>*1</sup>	23,000 ppm	23,000 ppm
Ethylene	C <sub>2</sub> H <sub>4</sub>	27,000 ppm <sup>*2</sup>	23,000 ppm	24,000 ppm
Ethane	C <sub>2</sub> H <sub>6</sub>	30,000 ppm <sup>*2</sup>	24,000 ppm	24,000 ppm
Ethanol	C <sub>2</sub> H <sub>5</sub> OH	33,000 ppm <sup>*2</sup>	31,000 ppm	31,000 ppm
Propylene	C <sub>3</sub> H <sub>6</sub>	20,000 ppm <sup>*2</sup>	20,000 ppm	18,000 ppm
Acetone	C <sub>3</sub> H <sub>6</sub> O	21,500 ppm <sup>*1</sup>	25,000 ppm	25,000 ppm
Propane	C <sub>3</sub> H <sub>8</sub>	20,000 ppm <sup>*1</sup>	17,000 ppm	17,000 ppm
Butadiene	C <sub>4</sub> H <sub>6</sub>	11,000 ppm <sup>*1</sup>	14,000 ppm	14,000 ppm
Cyclopentane	C <sub>5</sub> H <sub>10</sub>	14,000 ppm <sup>*4</sup>	14,000 ppm	14,000 ppm
Benzene	C <sub>6</sub> H <sub>6</sub>	12,000 ppm <sup>*1</sup>	12,000 ppm	12,000 ppm
N-hexane	n-C <sub>6</sub> H <sub>14</sub>	12,000 ppm <sup>*1</sup>	10,000 ppm	10,000 ppm
Toluene	C <sub>7</sub> H <sub>8</sub>	12,000 ppm <sup>*2</sup>	10,000 ppm	10,000 ppm
N-heptane	n-C <sub>7</sub> H <sub>16</sub>	11,000 ppm <sup>*2</sup>	8,500 ppm	8,000 ppm
Xylene	C <sub>8</sub> H <sub>10</sub>	10,000 ppm <sup>*2</sup>	10,000 ppm	10,000 ppm
N-nonane	n-C <sub>9</sub> H <sub>20</sub>	7,000 ppm <sup>*5</sup>	7,000 ppm	7,000 ppm
Ethyl acetate	EtAc	21,000 ppm <sup>*1</sup>	20,000 ppm	20,000 ppm
Isopropyl alcohol	IPA	20,000 ppm <sup>*2</sup>	20,000 ppm	20,000 ppm
Methyl ethyl ketone	MEK	18,000 ppm <sup>*2</sup>	15,000 ppm	15,000 ppm
Methyl methacrylate	MMA	17,000 ppm <sup>*2</sup>	17,000 ppm	17,000 ppm
Dimethyl ether	DME	30,000 ppm <sup>*1</sup>	27,000 ppm	27,000 ppm
Methyl isobutyl ketone	MIBK	12,000 ppm <sup>*3</sup>	12,000 ppm	12,000 ppm
Tetrahydrofuran	THF	20,000 ppm <sup>*2</sup>	15,000 ppm	15,000 ppm
Normal pentane	n-C <sub>5</sub> H <sub>12</sub>	15,000 ppm <sup>*2</sup>	11,000 ppm	11,000 ppm

\*1 Recommended Practices for Explosion-Protected Electrical Installations in General Industries (NIIS/1985)

\*2 Recommended Practices for Explosion-Protected Electrical Installations in General Industries (NIIS/2006)

\*3 Technical recommendations of the Research Institute of Industrial Safety (NIIS/1994)

\*4 Chemical Safety Management Data Book (The Chemical Daily Co., Ltd.)

\*5 Product Safety Data Sheet (Eishin Kagaku Co., Ltd.)

## 11-4 Product warranty

1. In the event of defects, we will repair the product at no cost for three years from the date of purchase as long as the product has been used correctly in accordance with the operating manual, labels affixed to the product, and other such warnings.
2. For information about repairs, maintenance, and after sales servicing, please contact Riken Keiki.
3. When on-site repairs are required at remote locations, we will request that you defray the cost of traveling to the site.
4. Even within the warranty period, a fee will be charged for repairs in the following cases:
  - (a) When the fault or damage is the result of erroneous operation, unwarranted repair, or modification.
  - (b) When faults or damages are due to the item being repaired or modified at service agencies other than Riken Keiki or service agencies designated by Riken Keiki.
  - (c) When the fault or damage is due to the item being incorrectly moved, transported, toppled, dropped, or stored after the product was purchased.
  - (d) When the faults or damages are due to external factors such as; acts of providence such as fire, earthquake, flood, lightning strikes, etc.; pollution; abnormal voltage; use of power sources outside of rated ranges (voltage, frequency); etc.
  - (e) When the cause of the fault is something other than this product.
  - (f) Replacement of consumable parts (e.g., battery and sensors)

## 11-5 Sensor warranty

1. In the event of defects, we will replace at no cost for three years from the date of purchase or the date on which the sensor was replaced for a fee, as long as the product has been used correctly in accordance with the operating manual, labels affixed to the product, and other such warnings. However, a condition of the sensor's warranty shall be maintenance performed at least once annually from the date of purchase or the date on which the sensor was replaced for a fee.
2. For information about repairs, maintenance, and after sales servicing, please contact Riken Keiki.
3. When on-site replacement is required at remote locations, we will request that you defray the cost of traveling to the site.
4. Even within the warranty period, a fee will be charged for replacement in the following cases:
  - (a) When replacement is required due to failure to comply with warnings in the operating manual, labels affixed to the product, and other such warnings.
  - (b) When faults or damages are due to the item being repaired or modified at service agencies other than Riken Keiki or service agencies designated by Riken Keiki.
  - (c) When the fault or damage is due to the item being incorrectly moved, transported, toppled, dropped, or stored after the product was purchased.
  - (d) When the faults or damages are due to external factors such as; acts of providence such as fire, earthquake, flood, lightning strikes, etc.; pollution; abnormal voltage; use of power sources outside of rated ranges (voltage, frequency); etc.
  - (e) When the cause of the fault is something other than this product.

---

## Revision history

Issue	Revision details	Issue date
0	First issue	2022/1/13
1	P.5 / 35 / 106 Note added	2023/3/7
2	ATEX, IECEx explosion-proof certification numbers changed, UKEX deleted, CE declaration revised	2024/5/31

---





# EU-Declaration of Conformity

Document No. 320CE24002



We, RIKEN KEIKI Co., Ltd. 2-7-6, Azusawa, Itabashi-ku, Tokyo, 174-8744, Japan declare under our sole responsibility that the following product conforms to all the relevant provisions.

Product Name Portable gas detector  
Model GX-Force

Council Directives	Applicable Standards
ATEX Directive (2014/34/EU)	EN IEC 60079-0:2018 EN 60079-1:2014 EN 60079-11:2012
EMC Directive (2014/30/EU)	EN 50270:2015/AC:2016-08
BATTERY Regulation ((EU)2023/1542)	-
RoHS Directive (2011/65/EU[1])	EN IEC 63000:2018

<sup>[1]</sup>Including substances added by Commission Delegated Directive (EU) 2015/863

EU-Type examination Certificate No. DEKRA 24ATEX0018X

Notified Body for ATEX DEKRA Certification B.V. (NB 0344)  
Meander 1051, 6825 MJ Arnhem  
P.O. Box 5185, 6802 ED Arnhem  
The Netherlands

Auditing Organization for ATEX DEKRA Certification B.V. (NB 0344)  
Meander 1051, 6825 MJ Arnhem  
P.O. Box 5185, 6802 ED Arnhem  
The Netherlands

The marking of the product shall include the following:

 II 1 G Ex da ia IIC T4 Ga (with catalytic gas sensor) -20°C ≤ Ta ≤ +60°C  
II 1 G Ex ia IIC T4 Ga (without catalytic gas sensor) -20°C ≤ Ta ≤ +60°C

Alternative Marking: -

Place: Tokyo, Japan

Date: May. 24, 2024

  
\_\_\_\_\_  
Takakura Toshiyuki  
General manager  
Quality Control Center