

EXPLOSION-PROOF CALORIMETER OHC-800 COMMON SPECIFICATION

Model	OHC-800
Measuring principle	RIKEN Opt-Sonic calculation through measurement of refractive index and sound speed
Measuring gas	See attached "Product Setup Sheet"
Measuring parameters	Calorific value gross/net, Relative density (specific gravity) Air=1.000, Wobbe index
Measuring range	See attached "Product Setup Sheet"
Measuring method	Constant-flow-rate gas introduction using sampling device
Self-monitoring/ diagnostic function	Status monitoring using four classification categories <ul style="list-style-type: none"> • FAILURE • FUNCTION CHECK • MAINTENANCE REQUIRED • OUT OF SPECIFICATION
Display	Full-dot LCD (with backlight) Lamps Green: Lights up at power on. Orange: Lights up in conjunction with Contact Output 1. Red: Lights up in conjunction with Contact Output 2. Green: Lights up in conjunction with Contact Output 3.
Outputs - Analog	4 - 20 mA DC (isolated, source current type) maximum load resistance of 300 Ω, minimum resolution under 0.01 mA
Outputs - Digital	RS-485 (MODBUS)
Outputs - Optical	Proprietary interface IrDA communication output for maintenance
Contact Output 1	Activated if the FUNCTION CHECK or OUT OF SPECIFICATION condition is met.* [No-voltage contact, contact capacity of 2 A, 30 VDC (resistance load)]
Contact Output 2	Activated if the FAILURE condition is met.* [No-voltage contact, contact capacity of 2 A, 30 VDC (resistance load)]
Contact Output 3	Activated if the MAINTENANCE REQUIRED condition is met.* [SSR contact, contact capacity of 20 W, 240 VAC (resistance load)]
How to operate	Operation using a magnet control key (The calorimeter can be operated while maintaining the explosion-proof performance.)
Power supply	100~240V AC±10% 50/60Hz, max. 18VA or 24 VDC ± 10%, max. 5 W* (The setting can be changed to either the AC or DC specifications.)
Protection class	Equivalent to IP66 or IP67
Operating temperature	Japan Ex :-20 to +57°C (at a constant condition) IECEX / ATEX / China Ex :-20 to +60°C (at a constant condition)
Operating humidity	95%RH or less (Non-condensing)
Measuring gas temperature	Same as ambient temperature (Without condensation)
Dimensions	Approx. 286 (W) x 453 (H) x 150 (D) mm (Excluding protrusions)
Weight	Approx. 23 kg
Explosion-proof structure	Flame-proof enclosures
Explosion-proof class	Japan Ex : Ex d II B+H ₂ T4 IECEX : Ex db II B+H ₂ T4 Gb ATEX : II 2 G Ex db II B+H ₂ T4 Gb China Ex : Ex d II B+H ₂ T4 Gb

* The operating conditions of contacts can be changed.

<Gas measuring unit> (including cable glands)

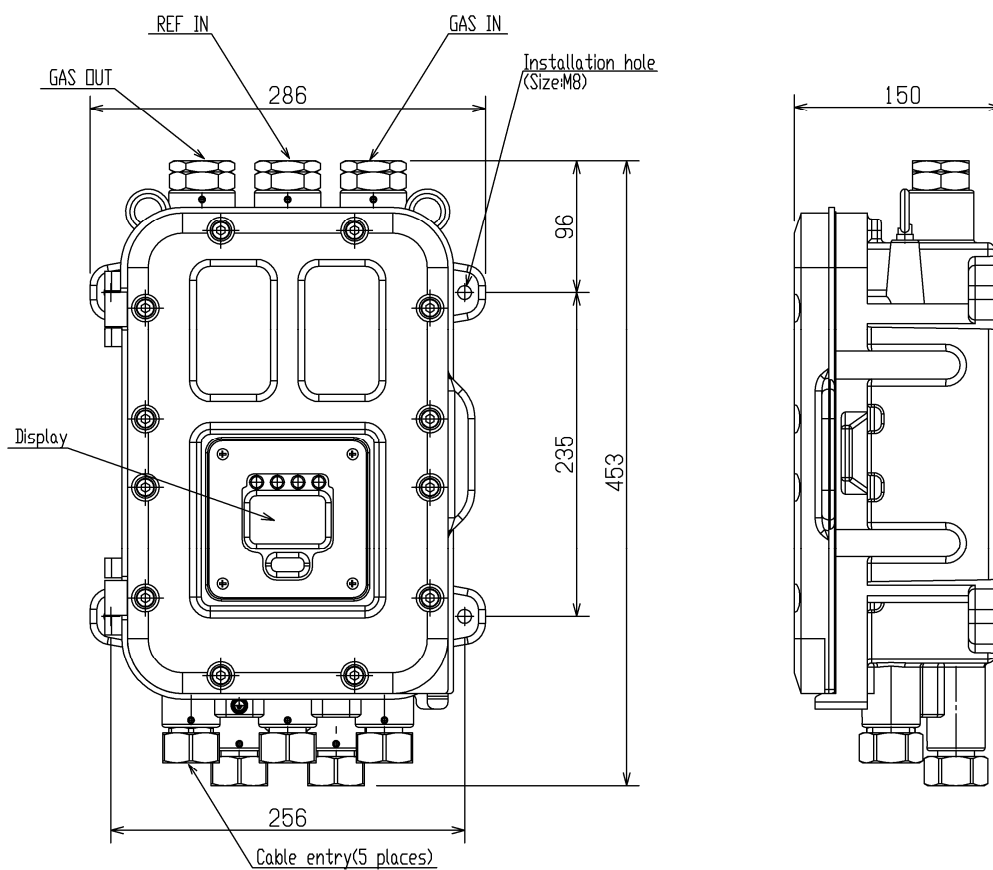

Terminal plate

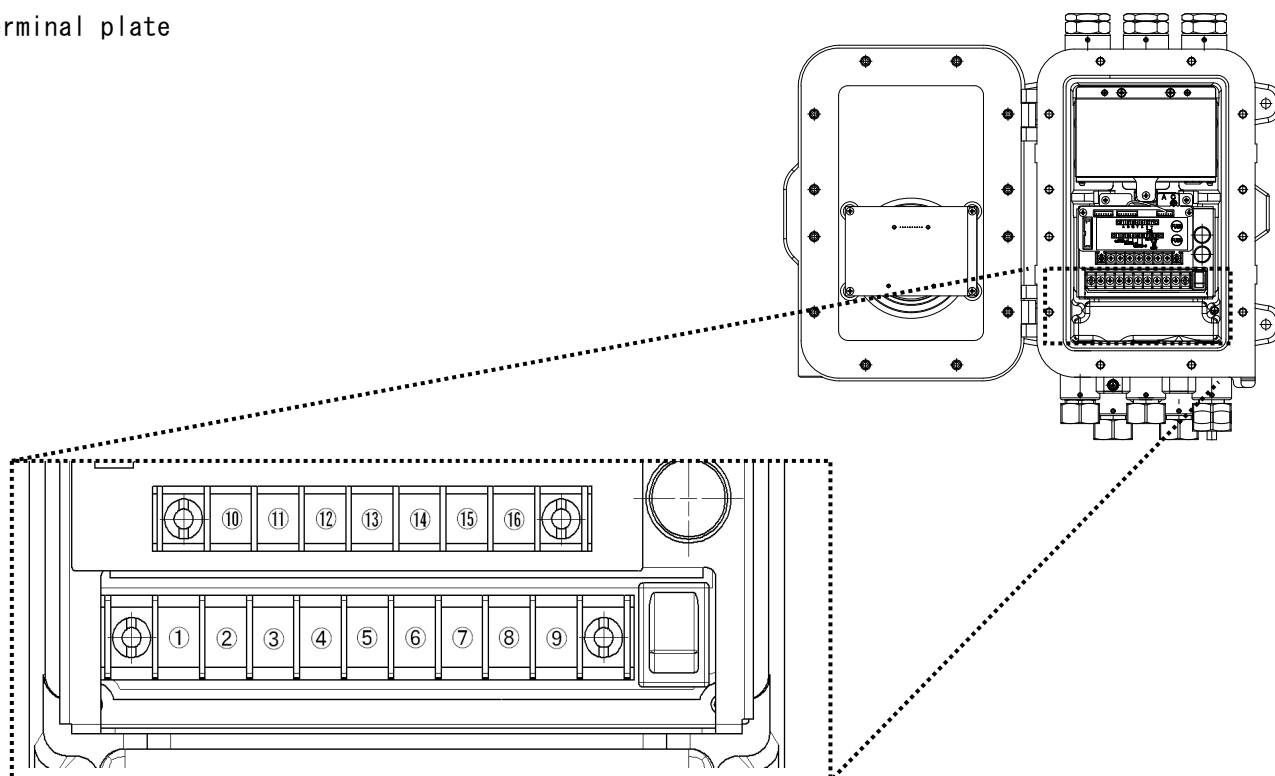

①	Contact output 1	CONTACT 1	Activates if the FUNCTION CHECK condition is met or the OUT OF SPECIFICATION condition is met. [No-voltage contact, contact capacity of 2 A, 30 VDC (resistance load)]
②			
③	Contact output 2	CONTACT 2	Activates if the FAILURE condition is met. [No-voltage contact, contact capacity of 2 A, 30 VDC (resistance load)]
④			
⑤	Contact output 3	CONTACT 3	Activates if the MAINTENANCE REQUIRED condition is met. [SSR contact, contact capacity of 20 W, 240 VAC (resistance load)]
⑥			
⑦	Power supply	FG	Functional Grounding (EARTH)
⑧		L / +	100~240V AC±10% 50/60Hz, max. 18VA or 24 VDC ± 10%, max. 5 W
⑨		N / -	(The setting can be changed to either the AC or DC specifications.)

⑩	Output - Digital	A	Receive Data +
⑪		B	Receive Data -
⑫		G	Signal Ground RS-485 (MODBUS)
⑬		Y	Transmit Data +
⑭		Z	Transmit Data -
⑮	Output - Analog	(+)	4 - 20 mA DC (isolated, source current type) Maximum load resistance of 300 Ω
⑯		(-)	Minimum resolution of 0.01 mA or less

M4 is used as the terminal screws for the terminal plate. Attach an insulated ring terminal for M4 to the tip of a cable for wiring.