



PT9E-01213

Fixed type Explosion-Proof Pump Unit
RP-D58-AC
RP-D58-DC
Operating Manual

RIKEN KEIKI Co., Ltd.

2-7-6 Azusawa, Itabashi-ku, Tokyo, 174-8744, Japan

Phone : +81-3-3966-1113

Fax : +81-3-3558-9110

E-mail : intdept@rikenkeiki.co.jp

Web site : <https://www.rikenkeiki.co.jp/>

<Contents>

1. Outline of the Product.....	1
1-1. Preface.....	1
1-2. Purpose of use.....	1
1-3. Definition of DANGER, WARNING, CAUTION, and NOTE.....	2
1-4. Method of confirmation for Standards and Explosion proof specification.....	2
2. Important Notices on Safety.....	3
2-1. Danger cases.....	3
2-2. Warning cases.....	4
2-3. Precautions.....	5
2-4. Safety Information.....	6
3. Product Components.....	10
3-1. Main unit and standard accessories.....	10
3-2. Names and functions for each part.....	12
3-3. Block diagram.....	15
4. How to Use.....	17
4-1. Before using the pump unit.....	17
4-2. Precautions for installation points.....	17
4-3. Precautions for system designing.....	18
4-4. How to install.....	20
4-5. How to wire.....	22
4-6. How to tube.....	29
5. How to Operate.....	30
5-1. Preparation for start-up.....	30
5-2. Basic operating procedures.....	30
5-3. How to start the pump unit.....	31
5-4. How to exit.....	32
6. Alarm Activation.....	33
7. Maintenance.....	34
7-1. Maintenance intervals and items.....	34
7-2. Parts replacement.....	40
8. Storage, Relocation and Disposal.....	41
8-1. Procedures to store the pump unit or leave it for a long time.....	41
8-2. Procedures to relocate the pump unit or use it again.....	41
8-3. Disposal of products.....	41
9. Troubleshooting.....	42
10. Product Specifications.....	43
10-1. List of specifications.....	43
10-2. Detection principle.....	48

1

Outline of the Product

1-1. Preface

Thank you for choosing our fixed-type explosion-proof pump unit RP-D58 series. Please check that the model number of the product you purchased is included in the specifications on this manual.



This manual explains how to use the pump unit and its specifications. It contains information required for using the pump unit properly. Not only the first-time users but also the users who have already used the product must read and understand the operating manual to enhance the knowledge and experience before using the pump unit.

1-2. Purpose of use

- This pump unit is a suction pump unit for attracting the gas revealed into the atmosphere and sending into a gas detector head.
- This pump unit is used combining the indicator/alarm unit and the gas detector head if needed. The pump unit can be used by itself, in order to function gas detector and gas detector head and low flow rate alarm, please use it pairing a directions alarm part. Read also the operating manual of the indicator/alarm unit.
- Please fully understand the features of the detector head before using it, so that it can be used properly.
- The pump unit draws abnormalities in the air caused by presence of gases or other reasons (leak) with the built-in pump.
- The pump unit has a built-in low flow rate detection function and can trigger a fault alarm when the flow rate inside the tubing drops below a fixed rate.
- The pump unit has two types of power supply specifications.

RP-D58-AC	AC power specification	100 - 110 VAC
RP-D58-DC	DC power specification	24 VDC

1-3. Definition of DANGER, WARNING, CAUTION, and NOTE

 DANGER	This message indicates that improper handling may cause death or serious damage on health or assets.
 WARNING	This message indicates that improper handling may cause serious damage on health or assets.
 CAUTION	This message indicates that improper handling may cause minor damage on health or assets.
NOTE	This message indicates advice on handling.

1-4. Method of confirmation for Standards and Explosion proof specification

This instrument has some specification depends on standard and explosion proof certificate. Please confirm the detector specification before using. Please refer Declaration of Conformity that is at the end of this manual if you have CE/UKCA marking type. You can confirm instrument specification to see name plate as follows.



ATEX/ CE/UKCA marking type name plate
(DC power specification only)

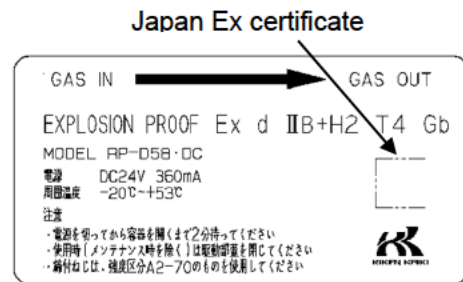

Japan Ex type name plate
(AC/DC power specification)

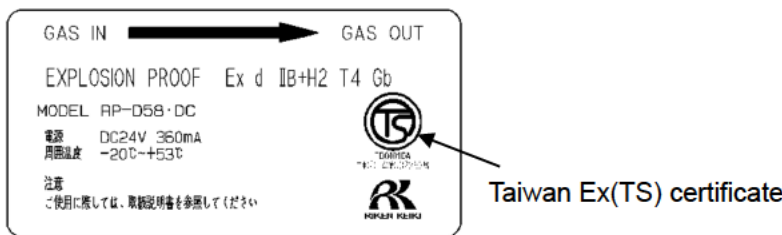

Taiwan Ex(TS) type name plate
(AC/DC power specification)

2

Important Notices on Safety

2-1. Danger cases

**DANGER**

<About explosion-proof>

- The window plate material is a polycarbonate resin. Do not use organic solvents and alkali types (liquid or vapor). It may cause the color and shape of the window plate to be changed.
- The flameproof joints are not intended to be repaired.
- Do not open the lid when applying current. The lid may be opened after five minutes or more after power off.
- Do not attempt to repair the pump unit by the user.
- For the lid, use hexagon socket head bolts specified by RIKEN KEIKI.
- The drive lid must be closed during use (except during maintenance).
- The pump unit is replaced once every two years.

2-2. Warning cases



WARNING

Power supply

Before turning on the pump unit, always check that the voltage is properly applied. Do not use an unstable power supply because it may cause malfunctions.

Need of grounding circuit

Do not cut the grounding circuit or disconnect the wire from the grounding terminal.

Defects in protective functions

Before starting the pump unit, check the protective functions for defects. When seeming defects are found in the protective functions, such as protective grounding, do not start the pump unit.

External connection

Before connecting the pump unit to the external control circuit, securely connect it to a protective grounding circuit.

Do not use the pump unit in the presence of silicone or sulfides.

The flow sensor is made of metal porous sintered alloy permeated with an oxidation catalyst. If silicon or sulfide compounds are accumulated on the surface of porous sintered alloy, the area of the gas sensing part becomes smaller, which may result in serious deterioration of its sensitivity.

2-3. Precautions



CAUTION

Do not use a transceiver or other equipment near the pump unit.

Radio wave from a transceiver near the pump unit or its cables may disturb operations. If a transceiver is used, it must be used in a place where it disturbs nothing.

To restart the pump unit, wait for five seconds or more before doing it.

Restarting the pump unit in less than five seconds may cause errors.

Do not disassemble/modify the pump unit, or change the settings if not necessary.

Disassembling/modifying the pump unit will invalidate the warranty of the performance. Changing the settings without understanding the specifications may cause alarm malfunctions. Please use the pump unit properly in accordance with the operating manual.

Avoid applying organic solvents and others to the window plate for a long time.

The window plate material is a polycarbonate resin. When organic solvents (liquid or highly-concentrated vapor) and others are applied to the plate for a long time, its color and shape may be changed.

Never fail to perform a regular maintenance.

A regular maintenance must be performed to ensure safety. Continuing to use the pump unit without performing maintenance will deteriorate the sensitivity of the sensor, thus resulting in inaccurate gas detection.

Do not use the pump unit under an inert gas atmosphere.

The flow rate cannot be measured correctly under an inert gas atmosphere such as He.

2-4. Safety Information

Necessary information for explosion proof construction of Model RP-D58·AC/ RP-D58·DC.

This product is an explosion-proof pump which is basically installing fixed place.

There is one point of contact and works by trouble.

<ATEX/UKEX Specifications>

Technical Data

(Protection Method)	Flameproof enclosure “d”
(Certificate numbers)	DNV 21 ATEX 63457X DNV 22 UKEX 25926X
(Group)	II
(Category)	2G
(Type of Protection and Marking code)	Ex db h II B+H2 T4
(Equipment Protection Level)	Gb
(Ambient Temperature)	-20°C to +53°C
(Electrical Data)	
Supply voltage :	24 Vdc(Typ.)
Relay : Contact output	DC30V or AC250V 0.5A
Sensor power supply : Flow sensor	DC2.0V 170mA
(Applicable Standard)	EN IEC 60079-0 : 2018, EN 60079-1: 2014 BS EN IEC60079-0:2018, BS EN 60079-1:2014

Specific conditions of “X”-mark:

Fasteners used for enclosure are from stainless steel property class A2-70.

Cable gland may not provide sufficient clamping. User shall provide additional clamping of the cable to ensure that pulling and twisting is not transmitted to the terminations.

Regarding ATEX specification, the measuring function according to Annex II paragraph 1.5.5 of the Directive is not covered by this EU-type examination.

It shall comply with the requirements from the relevant European harmonized standards which provide guidance on the performance of gas detection equipment and safety devices.

The measuring function according to schedule 1, paragraph 24 of the Regulation is not covered in this UK-type examination. It shall comply with the requirements from the relevant UK Designated Standards which provide guidance on the performance of gas detection equipment.

The flameproof joints not intended to be repaired.

Enclosure made of Aluminum – Avoid impact or Friction in the equipment.

Installation

【RP-D58·DC】

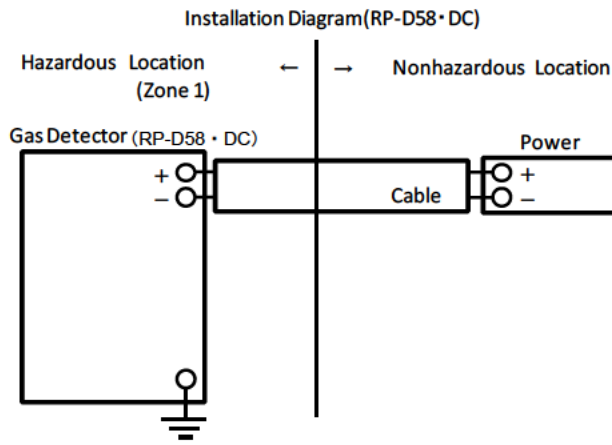

<Taiwan Ex(TS) Specifications>

Technical Data

(Protection Method)	Flameproof enclosure
(Explosion-proof class)	Ex d II B+H2 T4 Gb
(Ambient Temperature)	Type AC: -20°C to 50°C Type DC: -20°C to 53°C
(Electrical Data)	
Supply voltage :	Type AC: AC100~110V 50/60Hz 120mA Type DC: DC24V 360mA
Contact output :	AC250V 0.5A(Load resistance) DC30V 0.5A(Load resistance)
(Applicable Standard)	JNIOSH-TR-NO. 43(2008)

Installation

[RP-D58·AC]

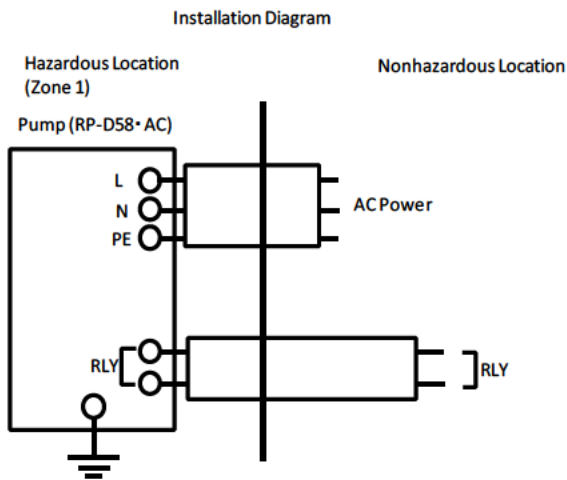

[RP-D58·DC]

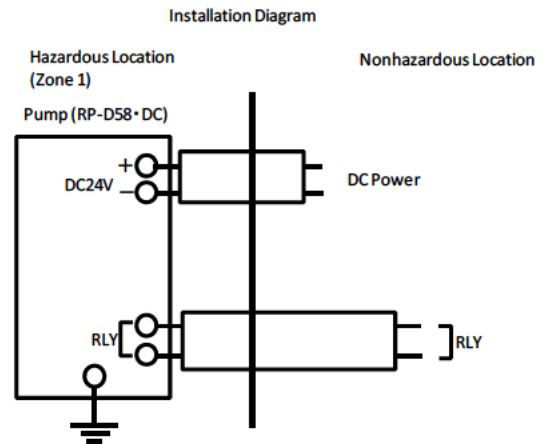

<Japan Ex Specifications>

Technical Data

(Protection Method)	Flameproof enclosure
(Explosion-proof class)	Ex d II B+H2 T4
(Ambient Temperature)	Type AC: -20°C to 50°C Type DC: -20°C to 53°C
(Electrical Data)	
Supply voltage :	Type AC: AC100~110V 50/60Hz 120mA Type DC: DC24V 360mA
Contact output :	AC250V 0.5A(Load resistance) DC30V 0.5A(Load resistance)
(Applicable Standard)	JNIOSH-TR-NO. 43(2008)

Installation

【RP-D58·AC】

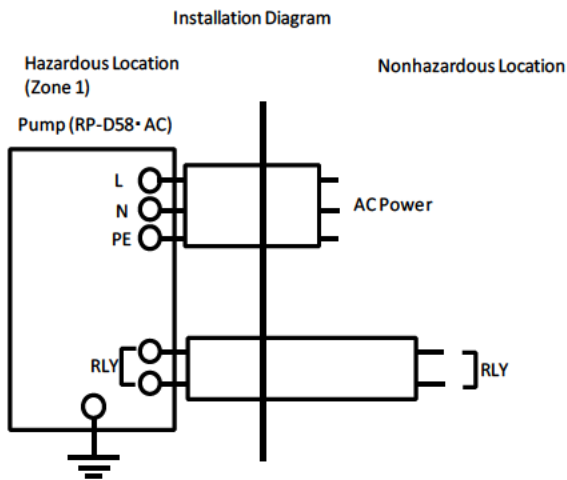

【RP-D58·DC】

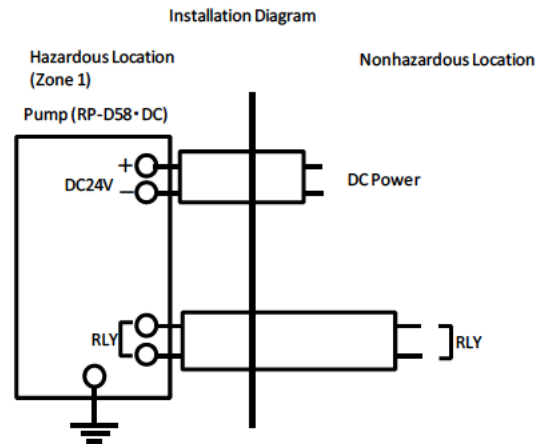

3

Product Components

3-1. Main unit and standard accessories

<Main Unit> (including cable glands)

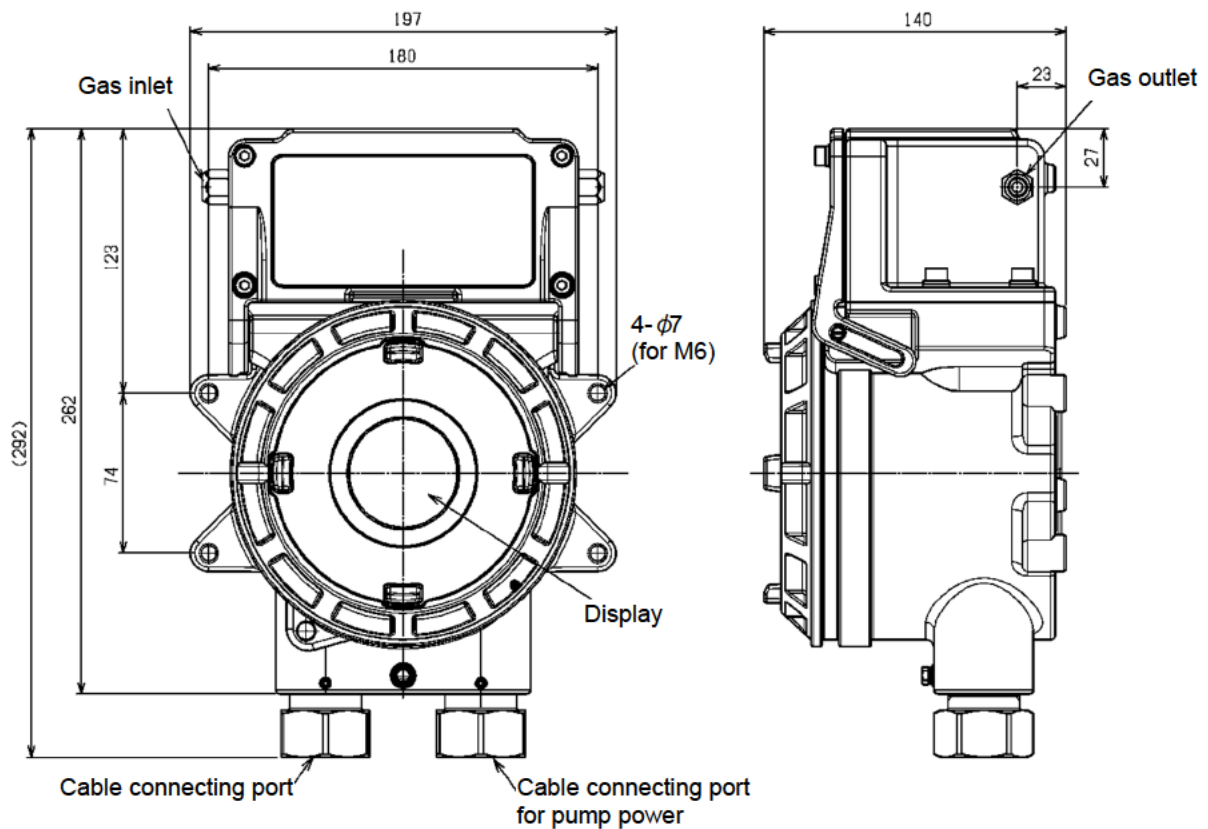

Unit: mm

<Standard Accessories>

- Operating manual
- Dedicated handling lever 1 lever
- Dedicated control key The control key quantity depends on the number of pump unit to be delivered.

1 - 10 units	1 key
11 - 20 units	2 keys
21 - 50 units	3 keys
Over 51 units	4 keys

- Hex key wrench Same number of wrenches as with the test certificates will be provided.
- Dust removal filter with flow monitor 1 filter



CAUTION

- Use the supplied dedicated control key to operate the pump unit. If products other than these accessories are used, key operations cannot be accepted properly.
- The control key is made of an extremely strong magnet. Keep it away from a credit card, ID card, or other magnetic product because stored data may be destroyed.

NOTE

The dedicated control key is for maintenance. It is not used for detection mode. Keep it handy for use.

3-2. Names and functions for each part

<Display>

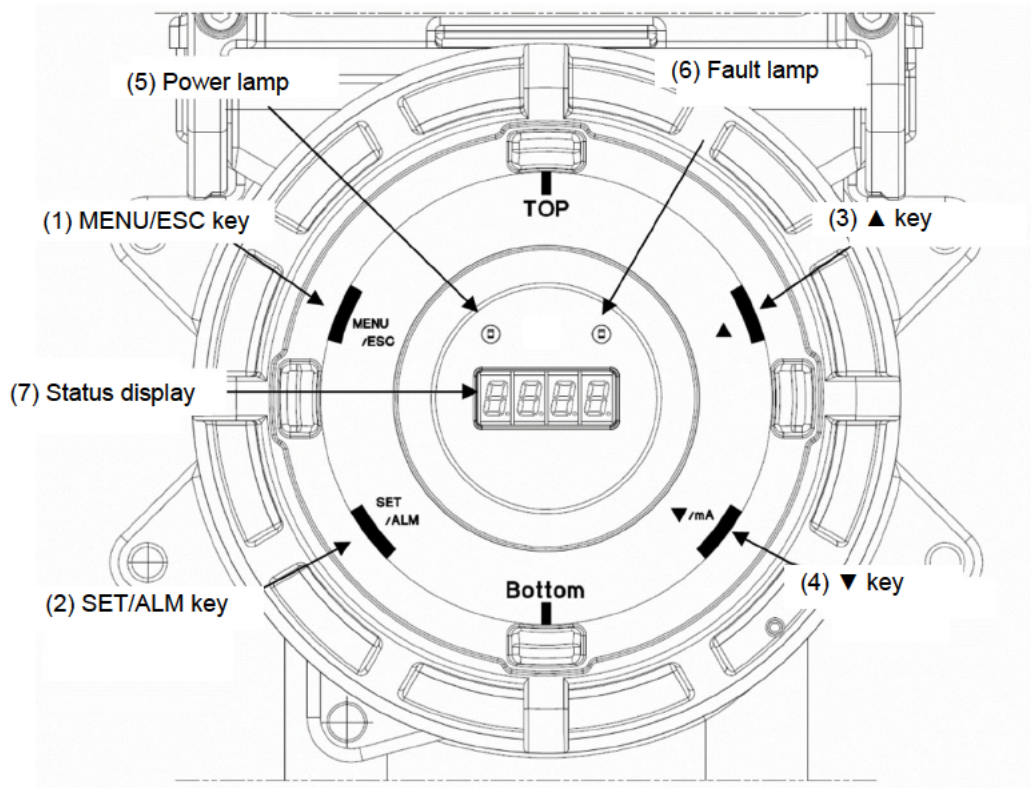

(1)	MENU/ESC key *	Used to enter the maintenance mode. It is also used to cancel in a specific mode.
(2)	SET/ALM key *	It is used for value confirmation and so on in a specific mode.
(3)	▲ key *	Used to switch menus or change a value (UP).
(4)	▼ key *	Used to switch menus or change a value (DOWN).
(5)	Power lamp	Power lamp. Detection mode: It lights up in green. Maintenance mode: It blinks in green.
(6)	Fault lamp	Fault lamp. It lights up in yellow when an abnormality is detected in the pump unit.
(7)	Status display	Displays the operating status.

* This is not typically used by the user.

NOTE

The nameplate on the front side of the pump unit shows the precautions to be taken for explosion-proof performances. Read these precautions as well as "2. Important Notices on Safety."

<Inside of the main unit> (Electric circuit section)

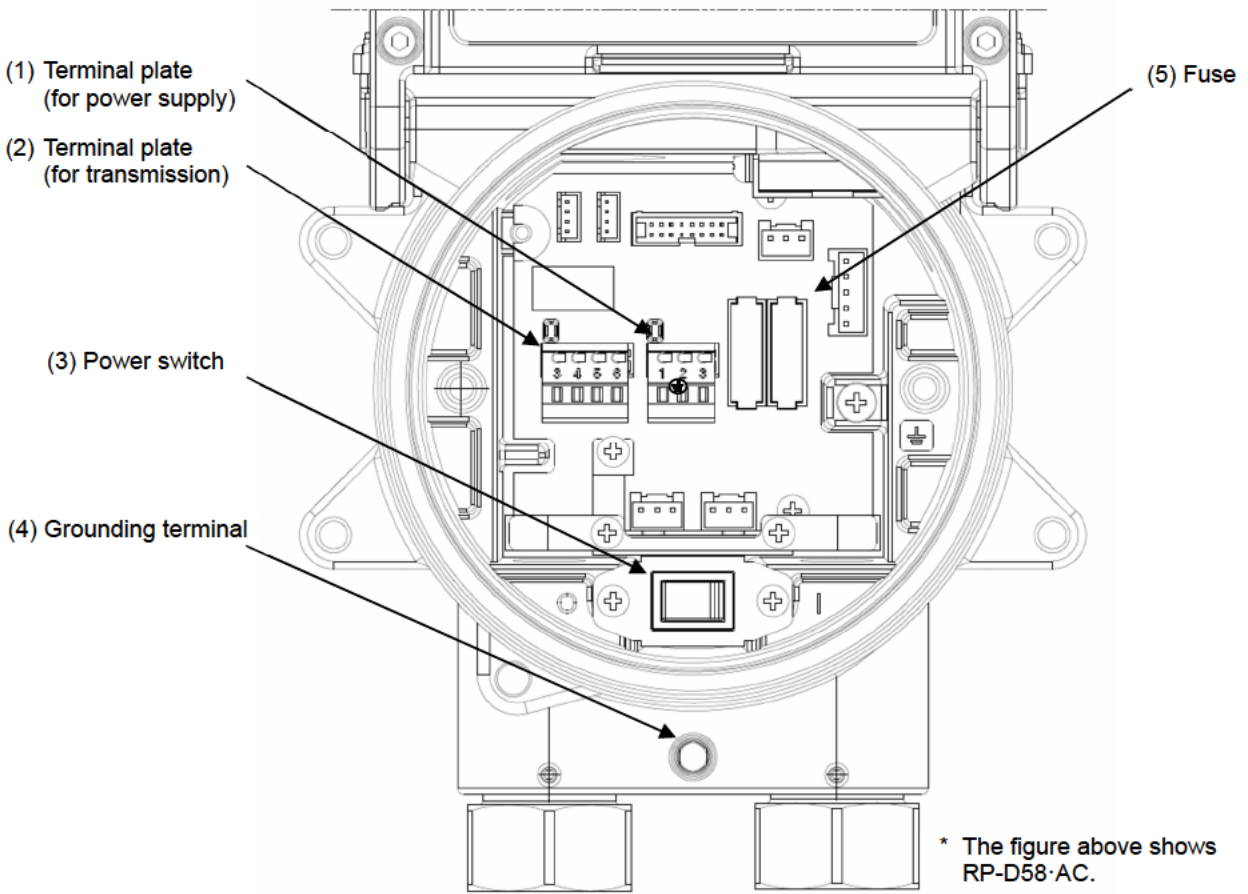

* The figure above shows RP-D58·AC.

(1)	Terminal plate (for power supply)	Power input terminal plate (RP-D58·AC: 3-pole, RP-D58·DC: 2-pole).
(2)	Terminal plate (for transmission)	Terminal plate for transmission.
(3)	Power switch	Power switch of the pump unit (RP-D58·AC only).
(4)	Grounding terminal	Terminal for grounding (M4 x 6).
(5)	Fuse	Main power fuse (RP-D58·AC only).

NOTE

- Open the electric circuit lid.
Remove the electric circuit lid and display unit to find behind them the electric circuit section shown in the figure above.

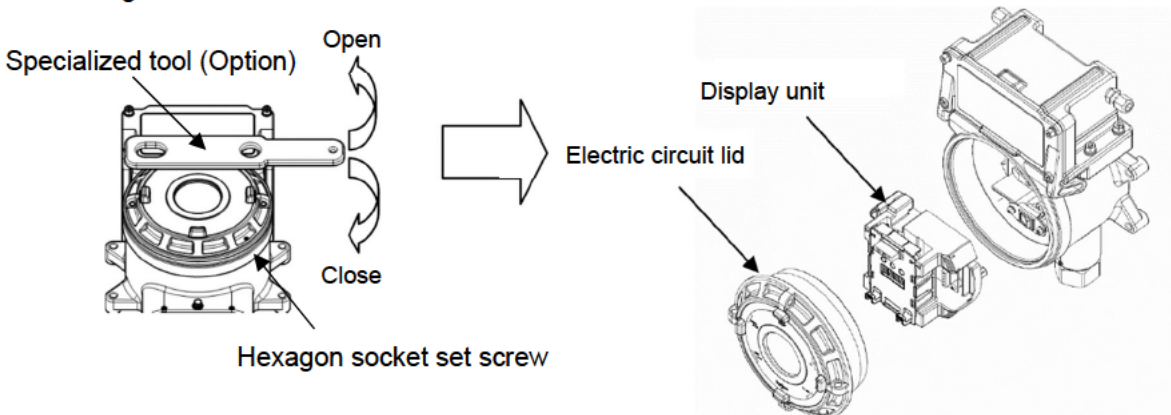

- Power input terminal plates are RP-D58·AC: 3-pole and RP-D58·DC: 2-pole.
After use, closely tighten the lid until the thread is no longer seen (clockwise 8 rotations +1/4 rotation or more) and the "TOP" marking faces upward. Tighten the hexagon socket set screw with a tightening torque of 107.8±12.7 N·cm.

<Inside of the main unit> (Drive section)

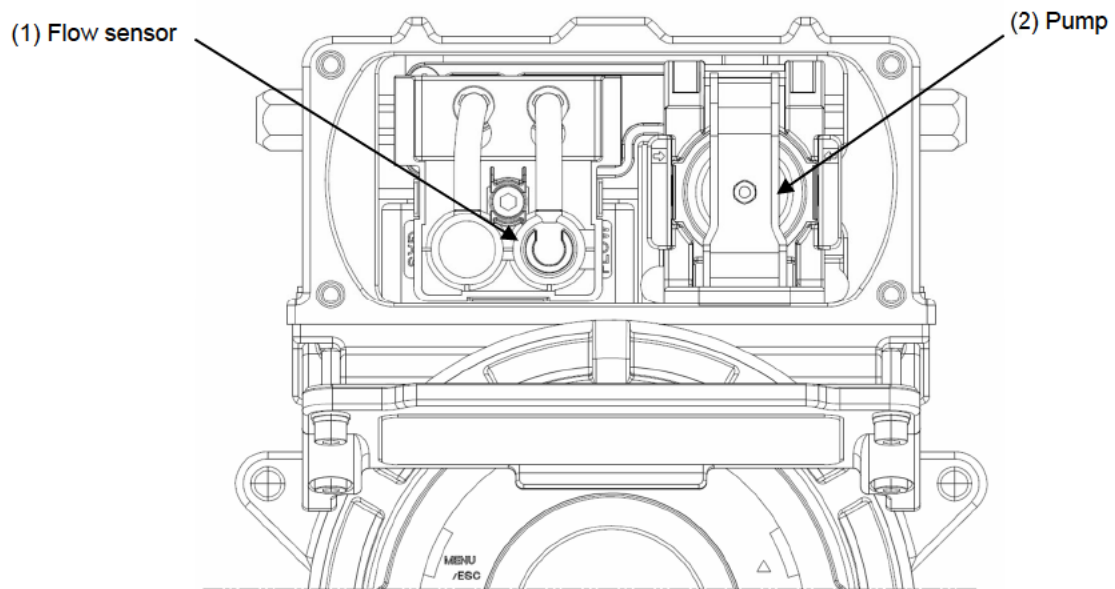

(1)	Flow sensor	Sensor for detection of low flow rate.
(2)	Pump	Sample draw pump.

NOTE

Loosen the drive lid and the hexagon socket head bolts on the four corners.

Remove the drive lid to find the drive section shown in the figure above.

The bolt with the hexagon socket must use the stainless steel material of property class "A2-70".

- Grease specified by RIKEN KEIKI : BARRIERTA JFE 552 (manufactured by NOK KLUBER)
If you can not prepare the specified grease, use one that meets the following requirements.

1. Material does not harden due to deterioration
2. Volatile solvent-free
3. Material does not cause corrosion at the surface
4. Silicon-free
5. Validation of suitability depends on the specifications of grease manufacturer

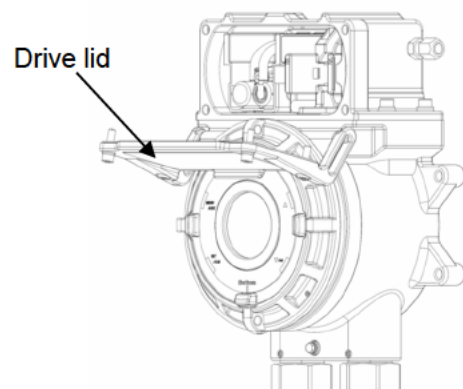

3-3. Block diagram

<Electric Diagram>

RP-D58-AC

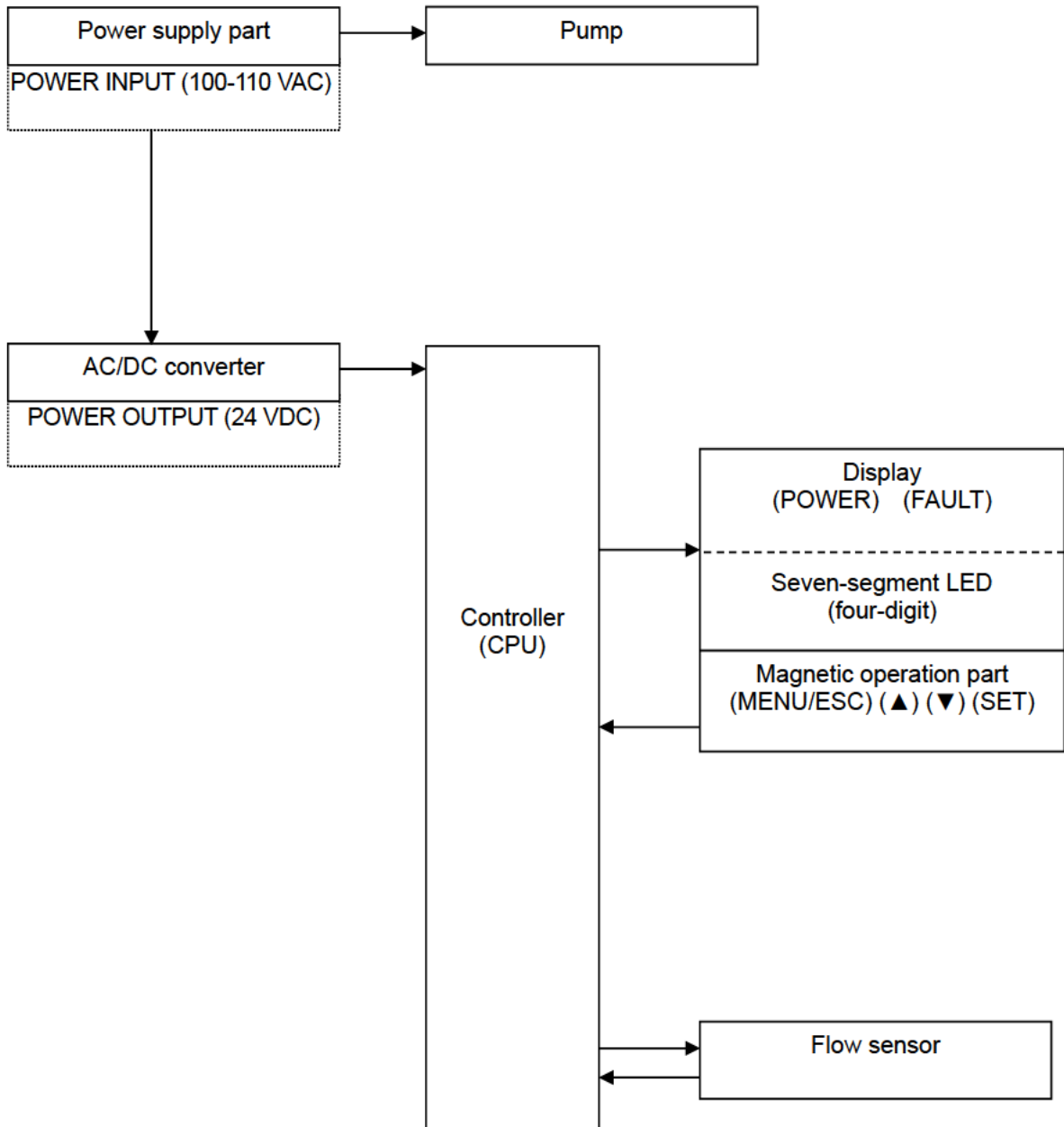

<Electric Diagram>

RP-D58·DC

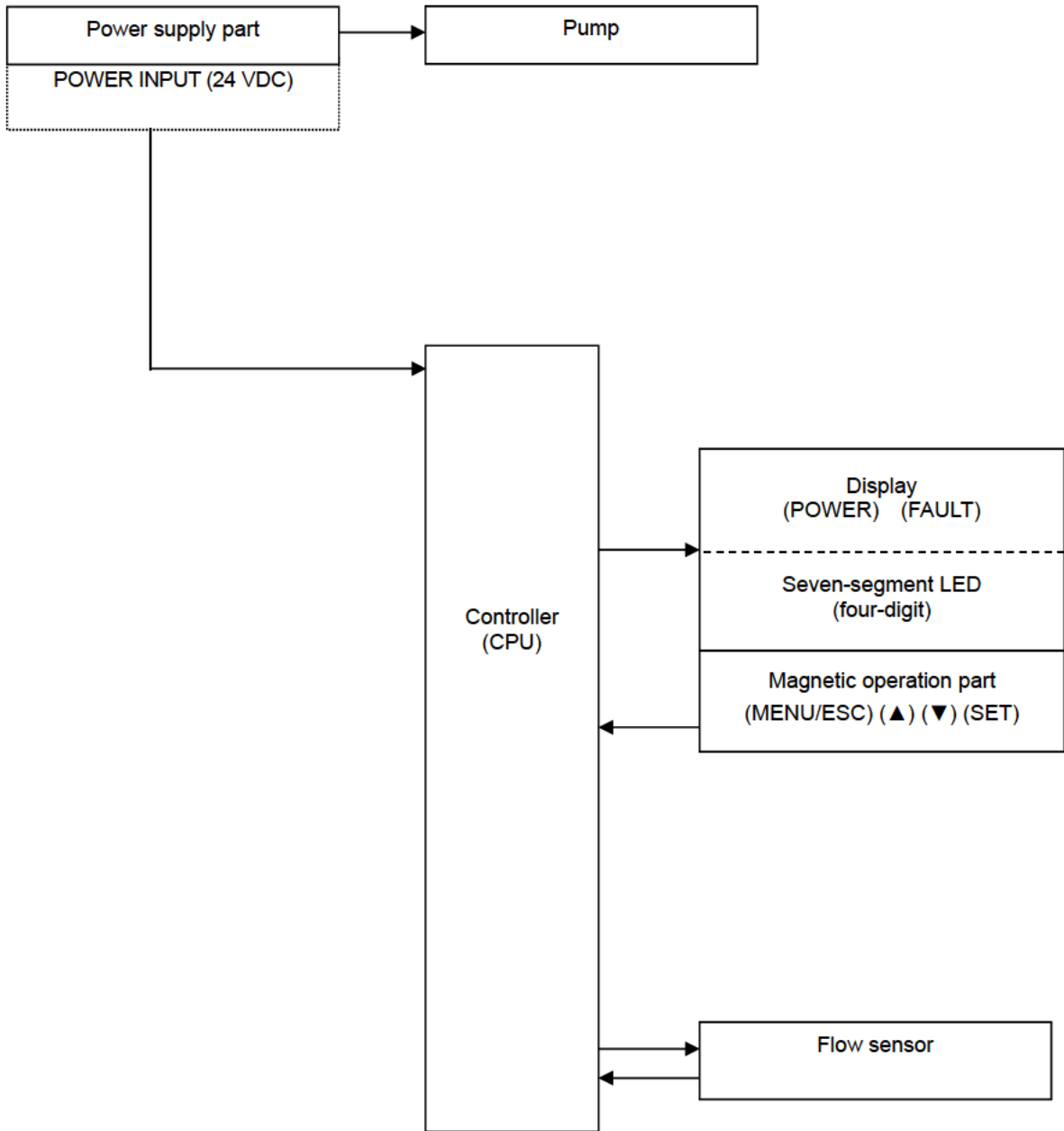

4

How to Use

4-1. Before using the pump unit

Not only the first-time users but also the users who have already used the product must follow the operating precautions.

Ignoring the precautions may damage the pump unit, resulting in inaccurate gas detection.

4-2. Precautions for installation points



CAUTION

- This pump unit is a precision device. Because the pump unit may not provide the specified performance in some places (environments), check the environment in the installation point, and then take appropriate actions if necessary.

Do not install the pump unit in a place with vibrations or shocks.

The pump unit consists of sensitive electronic parts. The pump unit must be installed in a stable place without vibrations or shocks and it cannot drop.

Do not install the pump unit in a place exposed to water, oil or chemicals.

When selecting installation points, avoid a place where the pump unit is exposed to water, oil or chemicals.

Do not install the pump unit in a place where the range of operating temperatures is exceeded.

The pump unit must be installed in a stable place where the operating temperature is maintained and do not change suddenly.

<ATEX/UKEX Specifications> RP-D58 • DC : -20°C~+53°C

<Taiwan Ex(TS) Specifications> RP-D58 • AC : -20°C~+50°C / RP-D58 • DC : -20°C~+53°C

<Japan Ex Specifications> RP-D58 • AC : -20°C~+50°C / RP-D58 • DC : -20°C~+53°C

Do not install the pump unit in a place exposed to direct sunlight or sudden changes in the temperature.

When selecting installation points, avoid a place where it is exposed to direct sunlight or radiant heat (infrared rays emitted from a high-temperature object), and where the temperature changes suddenly. Condensation may be formed inside the pump unit, or the detector head cannot adjust to sudden changes in the temperature.

Keep the pump unit (and its cables) away from noise source devices.

When selecting installation points, avoid a place where high-frequency/high-voltage devices exist.

Do not install the pump unit in a place where maintenance of the detector head cannot be performed or where handling the pump unit involves dangers.

Regular maintenance of the pump unit must be performed.

Do not install the pump unit in a place where the machinery must be stopped when maintenance is performed in its inside, where parts of the machinery must be removed to perform maintenance, or where the pump unit cannot be removed because tubes or racks prevent access to it. Do not install the pump unit in a place where maintenance involves dangers, for example, near a high-voltage cable.

Do not install the pump unit in machinery which is not properly grounded.

Before installing the pump unit in machinery, the machinery must be grounded properly.

Do not install the pump unit in a place where other gases exist around it.

The pump unit must not be installed in a place where other gases exist around it.

4-3. Precautions for system designing



CAUTION

An unstable power supply and noise may cause malfunctions or false alarms.

The descriptions in this section must be reflected on the designing of a system using the pump unit.

Using a stable power supply

The external output and alarm contact of the pump unit may be activated when the power is turned on, when momentary blackout occurs, or while the system is being stabilized. In such cases, use a UPS (uninterrupted power supply), or take appropriate actions on the receiving side of output signals.

The pump unit must be provided with the following power supply.

Power supply voltage	RP-D58-AC: 100 - 110 VAC \pm 10%, 50/60Hz: Terminal voltage of the pump unit RP-D58-DC: 24 VDC \pm 10%: Terminal voltage of the pump unit	
Allowed time of momentary blackout	RP-D58-AC: Less than approx. 200 msec (To recover from the momentary blackout for 200 milliseconds or more, restart the pump unit.) RP-D58-DC: Less than approx. 10 msec (To recover from the momentary blackout for 10 milliseconds or more, restart the pump unit.)	Example of actions To ensure continuous operation and activation, install an UPS outside the pump unit.
Others	Do not use it with a power supply of large power load or high-frequency noise.	Example of actions Use a line filter to avoid the noise source if necessary.

Introducing protective measures against lightning

If cables are installed outside the factory/plant, or if internal cables are installed in the same duct as the cables coming from outside the factory/plant, "lightning" will cause problems. Because lightning acts as a large emission source while cables act as a receiving antenna, devices connected to the cables may be damaged.

Lightning cannot be prevented. Cables installed in a metal conduit or under the ground cannot be completely protected from inductive lightning surge caused by lightning. Although complete elimination of disasters caused by lightning is impossible, the following protective measures can be taken.

Protection against lightning	<p><u>Take appropriate measures in accordance with the importance of the facilities and the environment.</u></p> <ul style="list-style-type: none"> • Provide protection by a lightning arrester (cable arrester). (Although inductive lightning surge can be transmitted through the cable, it is prevented by installing a lightning arrester before the field devices and central processing equipment. For information on how to use a lightning arrester, please contact the manufacturer.)
Grounding	<p>In addition to lightning, there are more sources of surge noise. To protect units from these noise sources, the units must be grounded.</p>

* The lightning arrester has a circuit to remove a surge voltage which damages field devices, so that signals may be attenuated. Before installing a lightning arrester, verify that it works properly.

4-4. How to install

<Installation Dimensions and Maintenance Space>

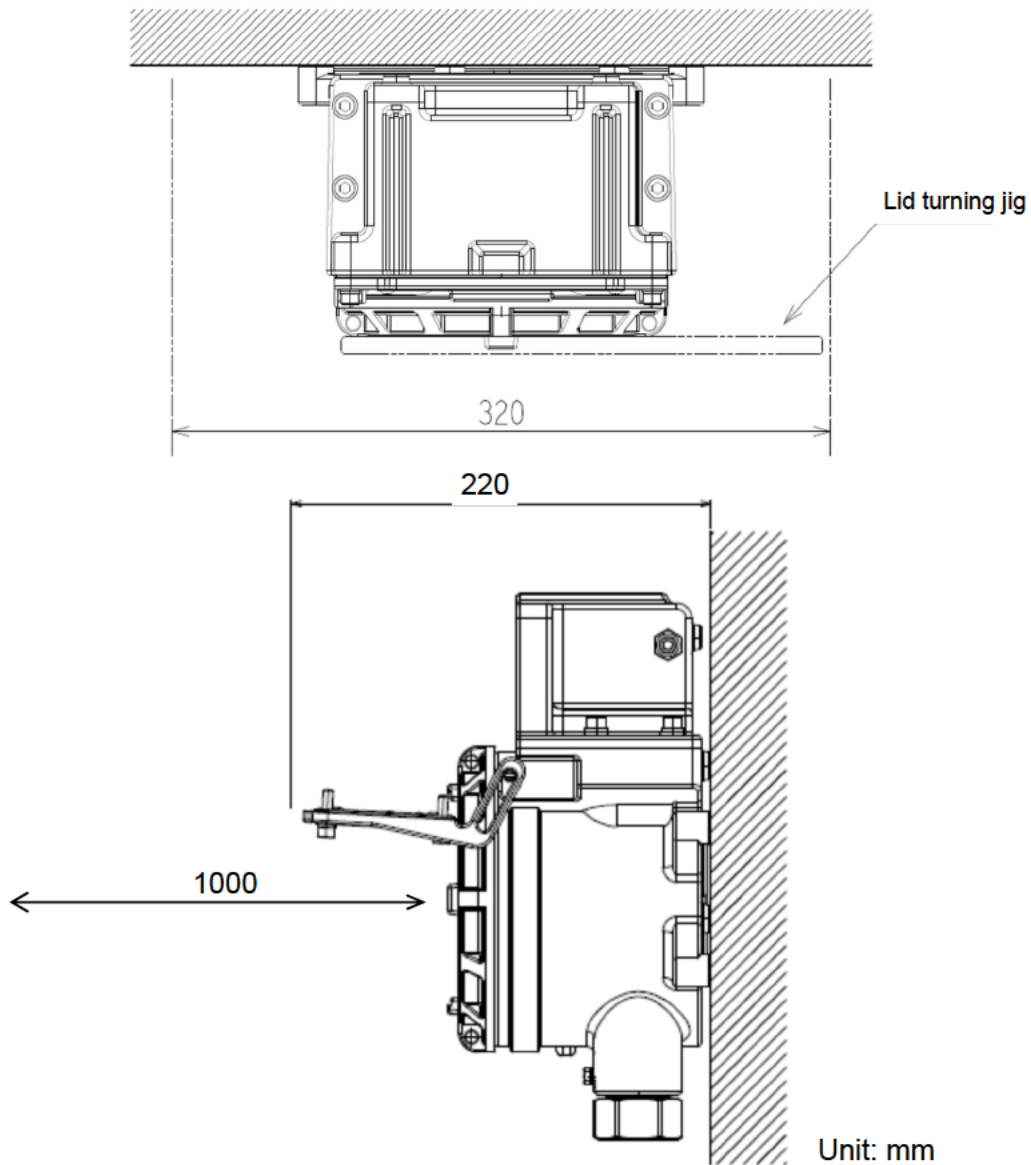

The following installation requirements must be met to install the pump unit.

- Attach the pump unit on the wall or elsewhere, using four M6 screws.
- Tighten the hexagon socket head cap bolt fixing the lid and the main body with a tightening torque of $215.6 \pm 24.5 \text{ N} \cdot \text{cm}$.
- When closing the lid of the detector, make sure that there is no dust on screw, surfaces of the main body and lid. Then apply grease as specified by RIKEN KEIKI.

**CAUTION**

Do not install the pump unit in a place where maintenance of the pump unit cannot be performed or where handling the pump unit involves dangers.

Regular maintenance of the pump unit must be performed.

Do not install the pump unit in a place where the machinery must be stopped when maintenance is performed in its inside, where parts of the machinery must be removed to perform maintenance, or where the pump unit cannot be removed because tubes or racks prevent access to it. Do not install the pump unit in a place where maintenance involves dangers, for example, near a high-voltage cable.

**CAUTION**

•Grease specified by RIKEN KEIKI : BARRIERTA JFE 552 (manufactured by NOK KLUBER)

If you can not prepare the specified grease, use one that meets the following requirements.

1. Material does not harden due to deterioration
2. Volatile solvent-free
3. Material does not cause corrosion at the surface
4. Silicon-free
5. Validation of suitability depends on the specifications of grease manufacturer

4-5. How to wire



WARNING

- When installing the electric circuit lid, do not let any foreign substance such as metal get into the terminal box.
This can cause a failure of the device or loss of explosion-proof performance.
- The lead-in wire to the pump unit must be installed in a way not to damage the explosion-proof performance of the pump unit.



CAUTION

- Be careful not to damage the internal electronic circuit when wiring. In addition, be careful not to apply stresses on the pump unit when (overweight) cables are installed.
- The power cables and signal cables must not be installed together with the motor power cables, etc. When these cables must be installed together for unavoidable reasons, put the power cables and signal cables in a metal conduit. The conduit must be connected to a grounding circuit.
- When stranded wires are used, prevent wires from contacting each other.
- Use the dedicated handling lever to wire.
- Use appropriate cables to wire.

<Recommended Cables>

RP-D58·AC

Power cable	CVV, etc. (1.25 mm ² or 2 mm ²) - 2-core or 3-core* ¹
Contact cable	CVVS, etc. (1.25 mm ² or 2 mm ²) - 2-core

RP-D58·DC

Power·contact cable	CVVS, etc. (1.25 mm ² or 2 mm ²) - 2-core<When the contact is not used.> CVVS, etc. (1.25 mm ² or 2 mm ²) - 4-core<When the contact is used.>
---------------------	--

*1 When internal grounding terminal poles are used.

<Parts. Length table of outside conductor lead-in>

<ATEX/UKEX Specifications> <Taiwan Ex(TS) Specifications>

Cable outer diameter (mm)	Rubber seal inner diameter (mm)	Washer inner diameter (mm)	Eccentric washer inner diameter (mm)
φ9.0 -φ9.6	φ10	φ10	φ9.8
φ9.6 -φ11.0	φ11	φ14	φ11.8
φ11.0 -φ12.0	φ12	φ14	φ12.8
φ12.0 -φ12.5	φ12.5	φ14	φ12.8
φ12.5 -φ13.5	φ13.5	φ14	φ13.8
φ13.5 -φ14.5	φ14.5	φ17	φ14.8
φ14.5 -φ15.5	φ15.5	φ17	φ15.8
φ15.5 -φ16.0	φ16.5	φ17	φ16.2
No cable	- (Plug)		

<Japan Ex Specifications>

Cable outer diameter (mm)	Rubber seal inner diameter (mm)	Washer inner diameter (mm)	Eccentric washer inner diameter (mm)
φ9.0 (allowable range:φ9.0 - φ9.6)	φ10	φ14	φ9.8
φ9.6 (allowable range:φ9.0 - φ9.8)	φ11	φ14	φ9.8
φ10.5 (allowable range:φ10.5 - φ11.0)	φ11	φ14	φ11.8
φ11.0 (allowable range:φ11.0 - φ11.5)	φ12	φ14	φ12.8
φ11.5 (allowable range:φ11.5 - φ12.0)	φ12	φ14	φ12.8
φ12.0 (allowable range:φ12.0 - φ12.5)	φ12.5	φ14	φ12.8
φ13.0 (allowable range:φ13.0 - φ13.5)	φ13.5	φ14	φ13.8
φ16.0 (allowable range:φ16.0 - φ16.2)	φ16.5	φ17	φ16.2
No cable	- (Plug)		

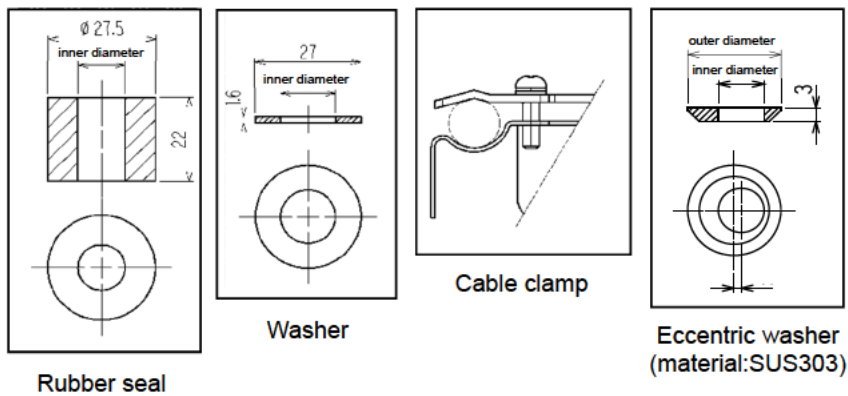

NOTE

- The following table shows an example of the outer diameters of the cables. Use them for reference. The outer diameters must be checked because they somewhat vary between manufacturers.

Number of core	CVV 1.25mm ²	CVV 2mm ²	CVVS 1.25mm ²	CVVS 2mm ²
2	φ 9.2	φ 10.5	φ 9.6	φ 10.5
3	φ 9.7	φ 11.0	φ 10.5	φ 11.0
4	φ 10.5	φ 11.5	φ 11.0	φ 12.0
5	φ 11.5	φ 12.5	φ 12.0	φ 13.0
6	φ 12.5	φ 13.5	φ 13.0	φ 14.0

<Figure of Terminal Plate>

RP-D58-AC

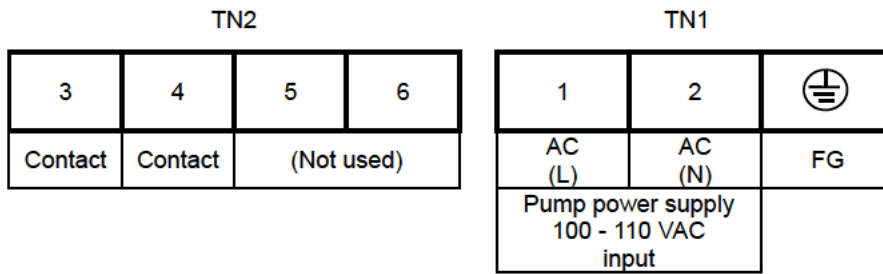

RP-D58-DC

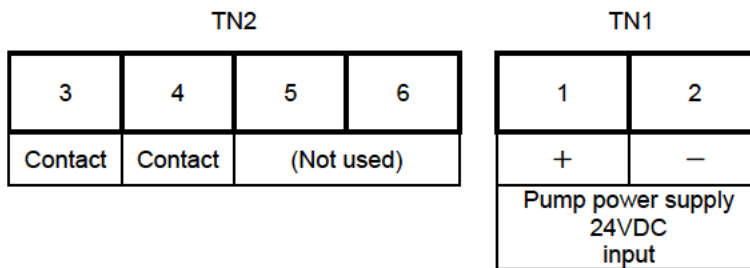

NOTE

- Open the electric circuit lid.
Remove the electric circuit lid and display unit to find behind them the terminal plate shown in the figure above.

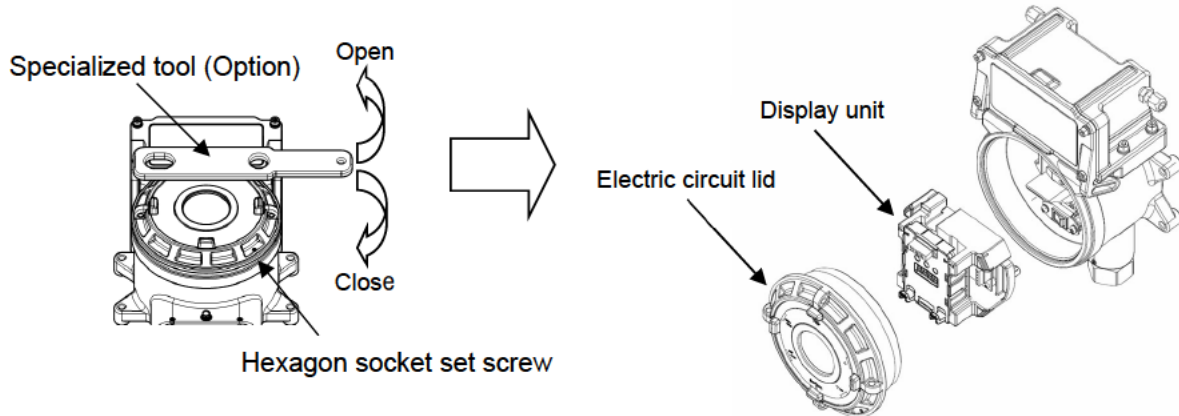

- Power input terminal plates are RP-D58-AC: 3-pole and RP-D58-DC: 2-pole.
- After use, closely tighten the lid until the thread is no longer seen (clockwise 8 rotations +1/4 rotation or more) and the "TOP" marking faces upward. Tighten the hexagon socket set screw with a tightening torque of 107.8±12.7 N·cm.

<Specifications of Terminal Plate>

Specifications of terminal plate

- Rated voltage: 250 VAC
 - Rated current: 12 A
- However, it depends on the cables to be used.

Connection conditions

- Cables: 0.25 - 2.5 mm²
- Bare wire length: 8 - 9 mm
- Connecting tool: Dedicated handling lever (accessory) or driver (edge 3.5 x 0.5 mm)



CAUTION

The specified bare wire length must be observed when the wire insulation is peeled off.

- Improper clamping of the wire due to a shorter bare wire length may cause defective electric conduction or heating.
- Catching the wire insulation due to a shorter bare wire length may cause defective electric conduction or heating.
- Exposing the wire due to a longer bare wire length may cause defective insulation or a short circuit.
- Be careful not to break up the wire. If the wire is broken up when inserted to the terminal, this may cause defective insulation or heating.

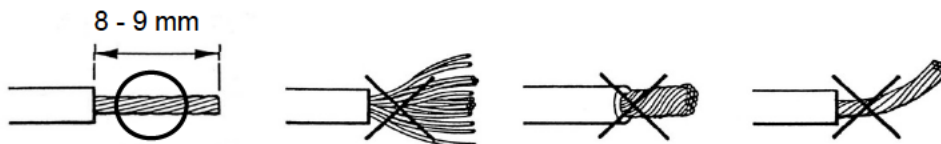

Compatible bar terminal

For a bar terminal, the following items are available.

- Bar terminal (ferrule): Model 216 Series (manufactured by WAGO)
- Crimping tool: Model VarioCrimp 4 (206-204) (manufactured by WAGO)



CAUTION

A bar terminal of the specified model must be used. Using other bar terminals invalidates the warranty of the performance.

<How to Connect to Terminal Plate>

When cables are connected to the connectors, use the dedicated lever or a flathead screwdriver to do it as shown below.



CAUTION

- The appropriate tools must be used.
- In principle, one wire can be connected to one wiring hole.
- When the wire is inserted into the driver slot by mistake, it does not contact the conductive part. This may cause defective electric conduction or heating. When the wire is inserted under the spring by mistake, it does not contact the conductive part. This may cause defective electric conduction or heating.

NOTE

<How to Use the Dedicated Handling Lever>

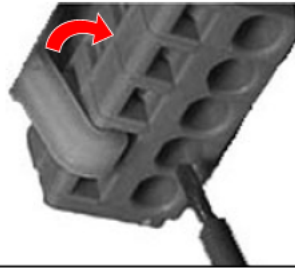

Push the lever with your finger to lower the spring in its inside.

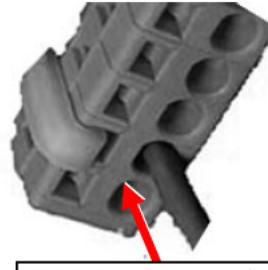

While holding down the lever, insert the wire into the (round) wiring hole until it reaches the deepest point. Once the lever is released, the wire is secured.

To check whether the wire is connected securely, pull the wire gently. (Do not pull the wire strongly.)

<Attaching External Cable>

As shown on the figure below, attach the parts in the following order: cable gland, eccentric washer, washer, and rubber seal to the cable, then connect the cable into the main unit, then screw the cable gland to tighten the rubber seal. When installing the cable gland, wipe the cable gland mounting part, the hexagon socket set screw, the grounding screw, and the cable gland and wipe the specified grease.

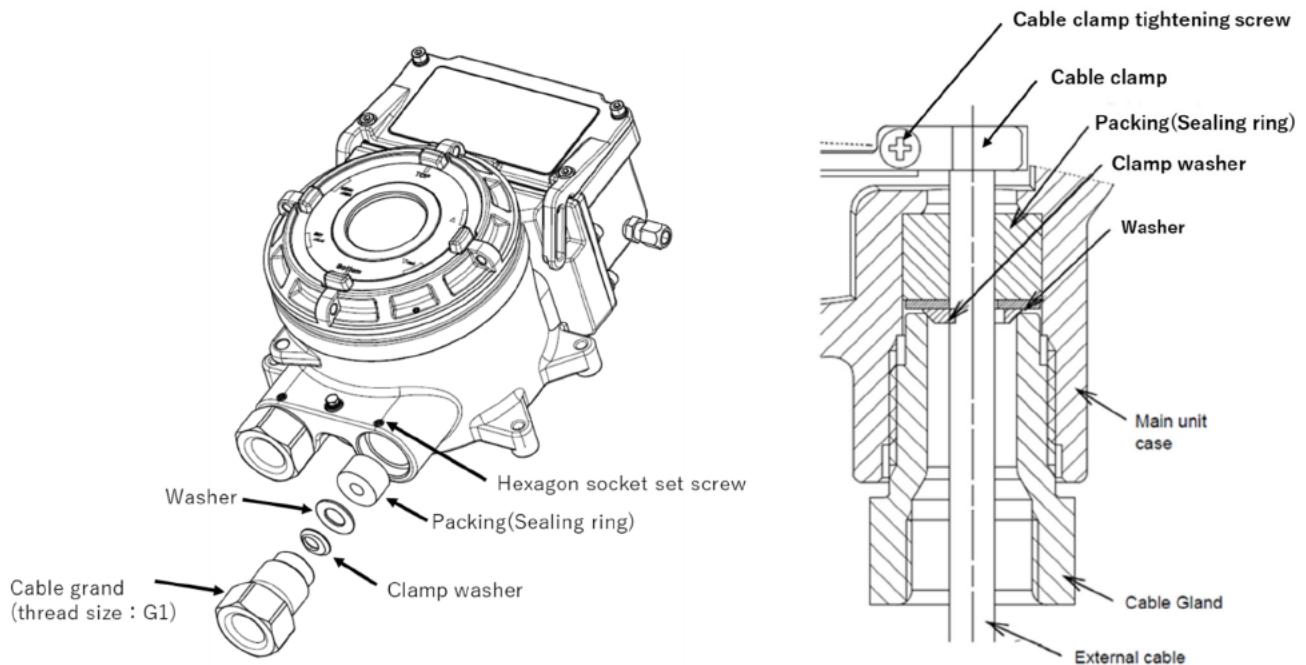

CAUTION

- Cable gland must be tightened with $40\text{N} \cdot \text{m}$ or more of torque.
- Maximum surface roughness of the enclosure face for sealing is $\text{Ra}6.3\mu\text{m}$.
- When installing the plug instead of the cable gland, tighten the plug to $40\text{N} \cdot \text{m}$.
- Tighten a cable gland with a tool until a clearance between the cable gland and a main unit case is below 2.0mm .
- Tighten the hexagon socket head cap screws fixing the cable gland with a tightening torque of $107.8 \pm 12.7\text{N} \cdot \text{m}$.



CAUTION

- Grease specified by RIKEN KEIKI : BARRIERTA JFE 552 (manufactured by NOK KLUBER)
If you can not prepare the specified grease, use one that meets the following requirements.
 1. Material does not harden due to deterioration
 2. Volatile solvent-free
 3. Material does not cause corrosion at the surface
 4. Silicon-free
 5. Validation of suitability depends on the specifications of grease manufacturer

<Grounding>

Connect the detector head  to your grounding terminal with the external grounding terminal.



WARNING

- Before turning on the pump unit, do not forget to connect it to a grounding terminal.
- For stable operation of the pump unit and safety, it must be connected to a grounding terminal. Do not connect the grounding wire to a gas pipe.
- The grounding must be made as D type grounding (below 100 Ω of grounding resistance).
- For the grounding wire, use cable lugs to safely connect it to a grounding terminal without looseness or twist.
- To connect the grounding wire to the internal grounding terminal of the unit, use a crimped terminal to which a wire with a cross-section area of 4 mm² or more can be attached.

<Wiring Example>

Connecting to the indicator/alarm unit

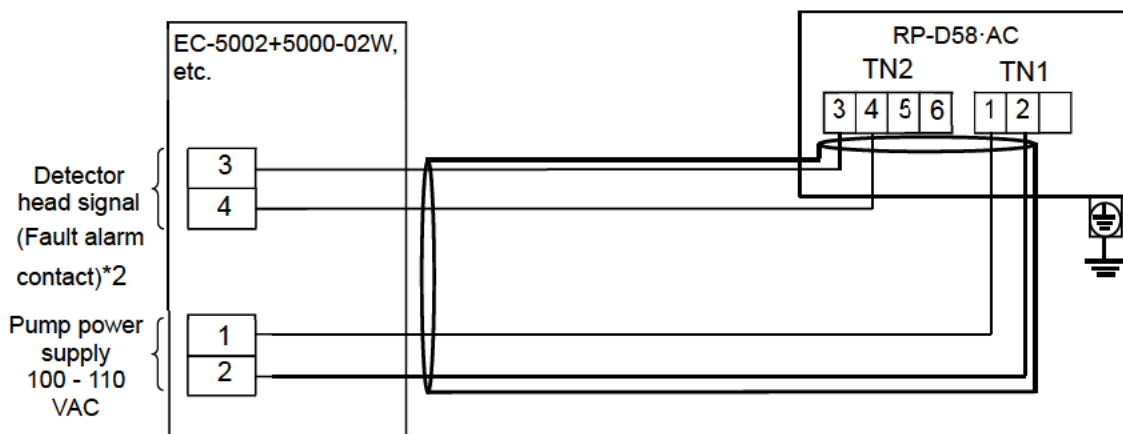
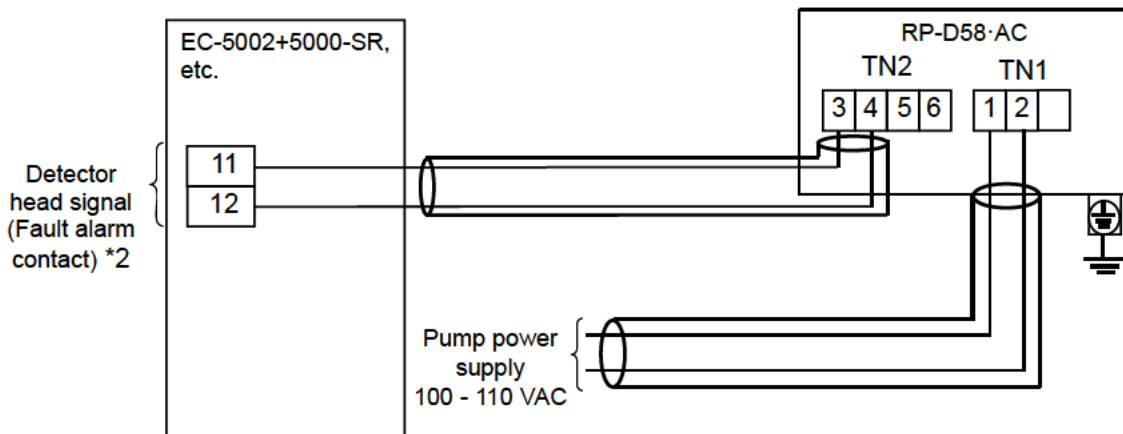

*1 The terminal plate number depends on the indicator/alarm unit. For details, see the operating manual of the indicator/alarm unit.

*2 When use indicator for fault alarm contact from RP-D58, please use these terminal plate.(Low flow rate contact is optional of EC-5002,OX-5002,RM-5002,and RM-5001.)

4-6. How to tube

The pump unit has an Rc1/8 thread inside of the sampling inlet/outlet (GAS IN, GAS OUT), to which BS unions are attached as standard. Because their material varies depending on the gas to be detected, please specify the material.

The compatible tube is a copper tube of $\Phi 8$ (OD) - $\Phi 6$ (ID). The tube must be installed with the supplied sleeves attached to prevent a leak.

When the tube is cut, its cut point may have a smaller inner diameter. Use a file etc. to expand the inner diameter of the cut point. To remove cut-dust remaining inside of the tube, blow compressed air etc. into the tube before connecting it to the pump unit.

Some sample gases have highly adsorptive or corrosive properties. Select the tube material taking into account these precautions.



WARNING

- The pump unit is designed to draw gases under the atmospheric pressure. If excessive pressure is applied to the sampling inlet and outlet (GAS IN, GAS OUT) of the pump unit, detected gases may be leaked from its inside, thus leading to dangers. Avoid applying excessive pressure to the pump unit while in use.
- Gases must be exhausted from the gas exhausting outlet (GAS OUT) to which an exhaust tube is connected, to a point regarded as a safe place.
- Do not use the pump unit in the presence of silicone or sulfides. The flow sensor is made of metal porous sintered alloy permeated with an oxidation catalyst. If silicon or sulfide compounds are accumulated on the surface of porous sintered alloy, the area of the gas sensing part becomes smaller, which may result in serious deterioration of its sensitivity.
- Do not use the pump unit under an inert gas atmosphere. The flow cannot be measured correctly under an inert gas atmosphere such as He.



CAUTION

- The longer the tube of the GAS IN is, the longer it takes for a sample gas to reach the pump unit. The length of the GAS IN tube must be minimized, since some gases have a highly adsorptive property which results in slower responses, and possibly a lower reading than the actual value.
- When the humidity in the sampling point is high, condensation may be formed inside of the tube. (Make sure to avoid condensation when using a gas such as a strong acid gas, which is dissolved into water and corrodes contacted materials, because it may result in undetectable condition and furthermore may corrode internal parts.) Also avoid an excessive U-shaped or V-shaped tube.
- Determine the inlet for the sample gas, considering the air flow of the sample gas line and the gas generating process.
- To remove dust, never fail to attach the supplied dust filter in the middle of the tube.
- It is needed to decide the length and material of the tube. Please contact RIKEN KEIKI for more information.
- Do not use the pump unit under an inert gas atmosphere. The flow rate cannot be detected correctly under an inert gas atmosphere such as He.
- During tubing work, do not bend tubes at a right angle but install them as straight as possible. Applying too much load on a tube may put too much strain on the pump of the pump unit and shorten the pump life. If bending of a tube is unavoidable, bend it with an appropriate radius to minimize strain.

5

How to Operate

5-1. Preparation for start-up

Before supplying power, read and understand the following precautions. Ignoring these precautions may cause an electric shock or damage the pump unit.

- Check that the pump unit is installed properly.
- Check that the pump unit is connected to a grounding circuit.
- Check that the wiring is connected to external device properly.
- Check that the tubes are installed properly.
- Check that the power supply voltage is compliant with the power supply specification and does not exceed the rating.

5-2. Basic operating procedures

Normally, the detection mode is activated after the power is turned on.

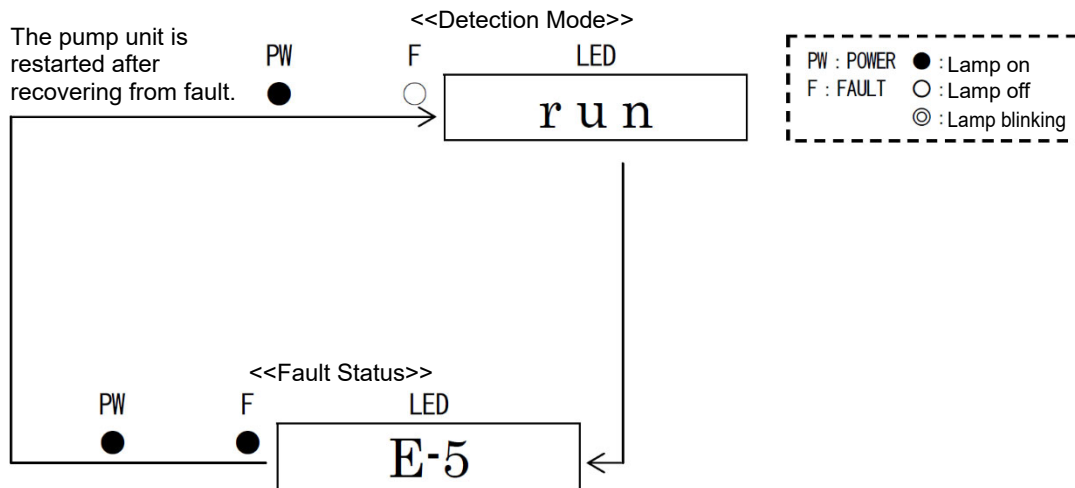

* Example of display: E-5 Low Flow Rate Alarm

5-3. How to start the pump unit

- Before supplying power to the pump unit, check that the preparation for start-up is completed.
 - Open the electric circuit lid.*
 - Turn ON the power switch.*
 - Close the electric circuit lid.*
 - Supply power to the pump unit.
 - After the pump unit completes the start-up, it enters the detection mode swiftly.
- * Only RP-D58-AC has a power switch. Since RP-D58-DC does not have any power switch, there is no need to open or close the electric circuit lid.

DANGER

Do not turn off the pump unit during the initial clear. The pump unit is reading the internal memory during the initial clear.

NOTE

- <<Start-up Operation Procedures>> (approximately 25 seconds for system check of the pump unit and alarm deactivation)
Power on -> Initial clear (approximately 25 seconds) -> Detection mode
- The gas detection is not yet started just after the pump unit is started up. Refer to see the operating manual of the indicator/alarm unit and gas detector head.

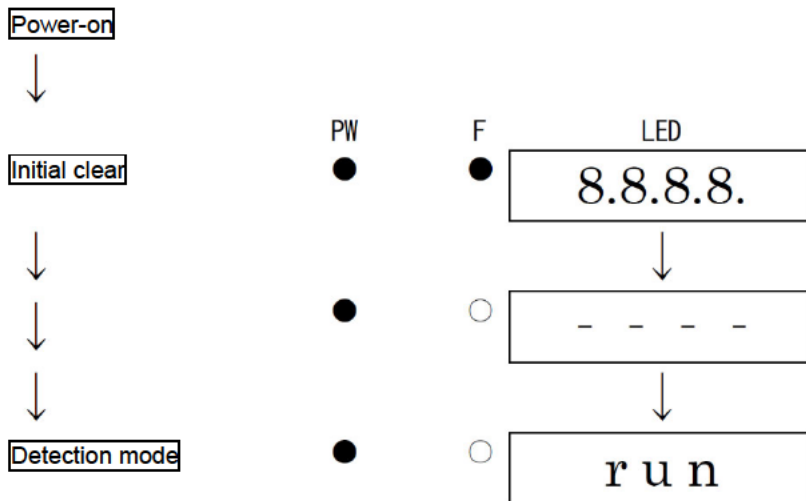

5-4. How to exit

- Turn OFF the power switch of the indicator/alarm unit.*1
- Turn off the power supply to the pump unit.
- Open the electric circuit lid.*2
- Turn OFF the power switch of the pump unit.*2
- Close the electric circuit lid.*2

*1 In case of used in combination with indicator/alarm unit.

*2 Only RP-D58·AC has a power switch. Since RP-D58·DC does not have any power switch, there is no need to open or close the electric circuit lid.



WARNING

- When the pump unit is turned off, an alarm may be triggered on the upper (central) system.
- Before turning off the pump unit, INHIBIT (point skip) on the upper (central) system must be activated. Decide whether the power can be turned off by checking the operation of the devices connected to the external output or external contact output terminal of the pump unit.

6

Alarm Activation

A fault alarm is triggered when the pump unit detects abnormalities. After a fault alarm is triggered, the fault lamp (yellow) lights up and an error message is displayed on the LED. Determine the causes and take appropriate actions.

After the pump unit is successfully returned from the fault, it restarts with the process normally performed right after it is turned on (initial clear).

If the pump unit has problems and is repeatedly malfunctioning, contact RIKEN KEIKI immediately.

<Low Flow Rate Abnormal Operations>

This alarm is triggered when the output value of the low flow sensor drops below the alarm setpoint. The alarm is auto-reset when the flow rate exceeds a certain level.

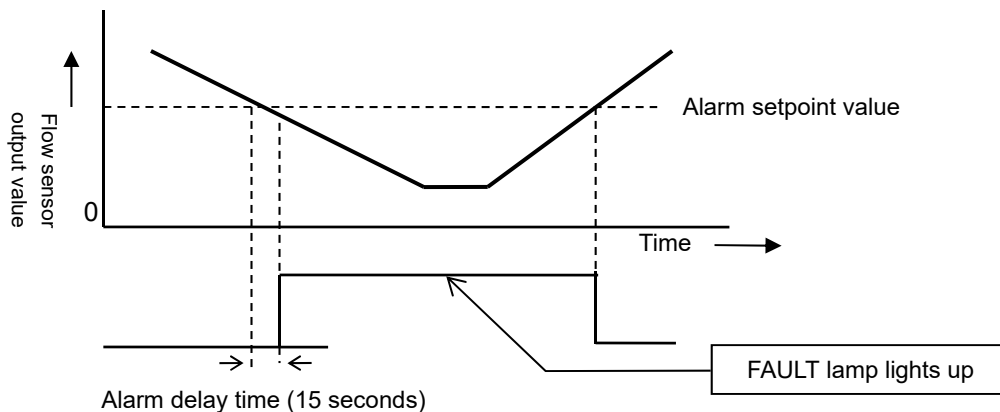

NOTE

- A low flow rate abnormality can be a cause of fault alarm.
For information on malfunctions (error messages), see "9. Troubleshooting".
- When a fault alarm is triggered, the indicator/alarm unit reports a sensor abnormality or fault alarm*.
 - * In case of used in combination with indicator/alarm unit.
 - * The display of an alarm depends on the indicator/alarm unit. For details, see the operating manual of the indicator/alarm unit.

7

Maintenance

The pump unit is an important instrument for the purpose of safety.

To maintain the performance of the pump unit and improve the reliability of safety, perform a regular maintenance.

Continuing to use the pump unit without performing a maintenance will compromise the sensitivity of the gas sensor, thus resulting in inaccurate detection.

7-1. Maintenance intervals and items

- Daily maintenance: Perform maintenance before beginning to work.
- Regular maintenance: Perform maintenance once or more every six months to maintain the performance as a safety unit.

Maintenance item	Maintenance content	Daily maintenance	Regular maintenance
Power lamp check	Check that the power lamp lights up.	○	○
Status display check	Check that the status display is "run" and that the fault lamp is off.	○	○
Flow rate check	Check that the float of the dust removal filter with flow monitor is visible.	○	○
Flow sensor check	Check the flow sensor by using the test pump.	-	○

7-2. Maintenance mode (Regular maintenance)

WARNING

After the adjustment is completed, never fail to press MENU/ESC key to return to the detection mode.
(If the detector head remains in the maintenance mode, it automatically returns to the detection mode in ten hours.)

Mode	Item	LED display	Details
Maintenance mode (Regular maintenance)	Test mode	2-0	Performs various tests. 2-0.2 Fault test 2-0.3 LED test 2-0.4 Memory test
	Environmental setting	2-4	Used for various environmental settings. 2-4.8 Energized/de-energized contact setting 2-4.E Password setting 2-4.F Sensor fault alarm pattern setting
	Electrical setting display	2-5	Displays various electrical settings. This is not typically used by the user.
	Flow sensor setting	2-6	2-6.0 Flow sensor heater voltage adjustment 2-6.1 Flow rate zero point setting 2-6.2 Low flow rate threshold value setting 2-6.3 Flow sensor zero point check 2-6.4 Flow sensor output check 2-6.5 Pump output check 2-6.7 Flow sensor operation start setting 2-6.8 Low flow rate alarm delay time setting 2-6.9 Flow sensor function ON/OFF setting
	Flow sensor various setting display	2-7	Displays various settings of the flow sensor. This is not typically used by the user.
	Switches to factory mode	2-8	Not used.
	Switches to user mode	2-9	Returns to the user mode.

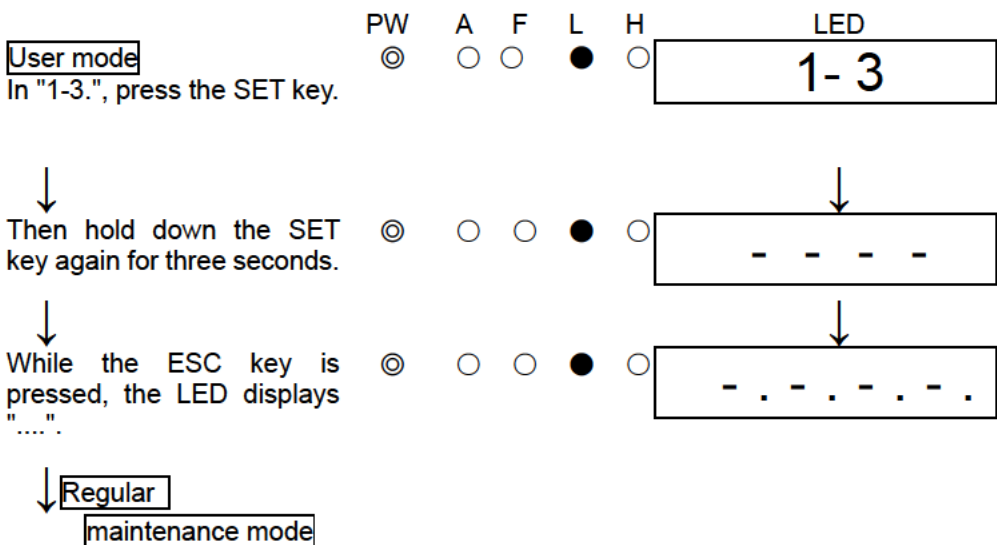

7-3. Flow sensor setting

<Flow Sensor Setting "2-6">

Flow rate zero adjustment "2-6.1"

This is used to perform the zero adjustment on the flow sensor.



CAUTION

- Before starting the zero adjustment of the flow sensor, remove the pump and wait until the flow sensor output is stabilized.

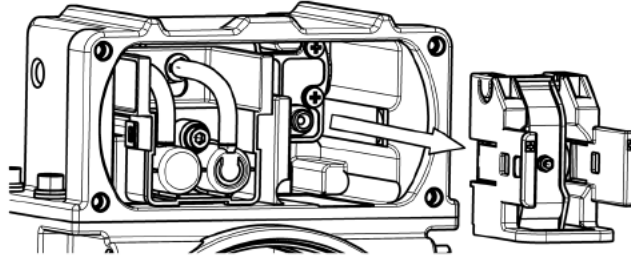

2-6.1

Press the SET key.



Current flow sensor output display

Press the SET key to perform the zero adjustment.



Under zero adjustment (CAL. is displayed)

Wait for a while until the adjustment is completed.



Zero adjustment completed

It automatically returns to 2-6.1 after PASS is displayed.

PW	A	F	LED
◎	○	○	2- 6.1



◎	○	○	1300
---	---	---	------



◎	○	○	CAL.
---	---	---	------



◎	○	○	PASS
---	---	---	------



Return to **2-6.1**.

* If the zero adjustment failed, it automatically returns to 2-6.1 after FAIL is displayed.

◎	○	○	FAIL
---	---	---	------



Return to **2-6.1**.

<Low Flow Rate Threshold Setting “2-6.2”>

This is used to set the threshold value for low flow rate.



CAUTION

Set the threshold value for low flow rate to one of the symbols ("a" to "e") printed on the flow sensor. If any other setting is used, the low flow rate function may not operate correctly.

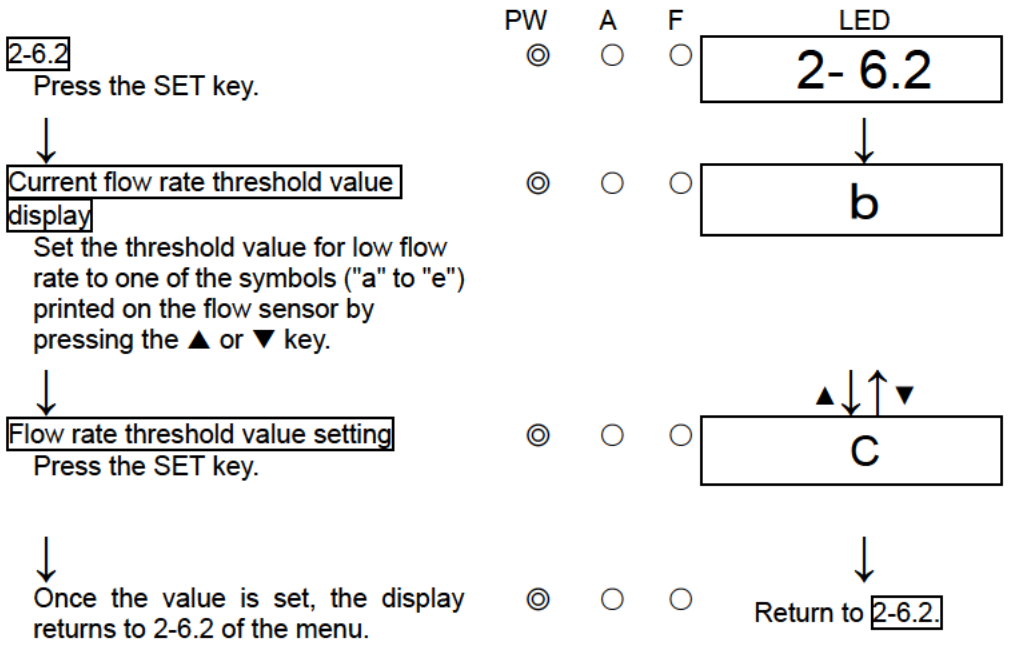

<Flow Sensor Operation Start Setting “2-6.7”>

This is used to set the flow sensor operation start.



CAUTION

- Make this setting only once at the operation start of the flow sensor.
- Make this setting after conducting the flow rate zero adjustment and setting the threshold value.

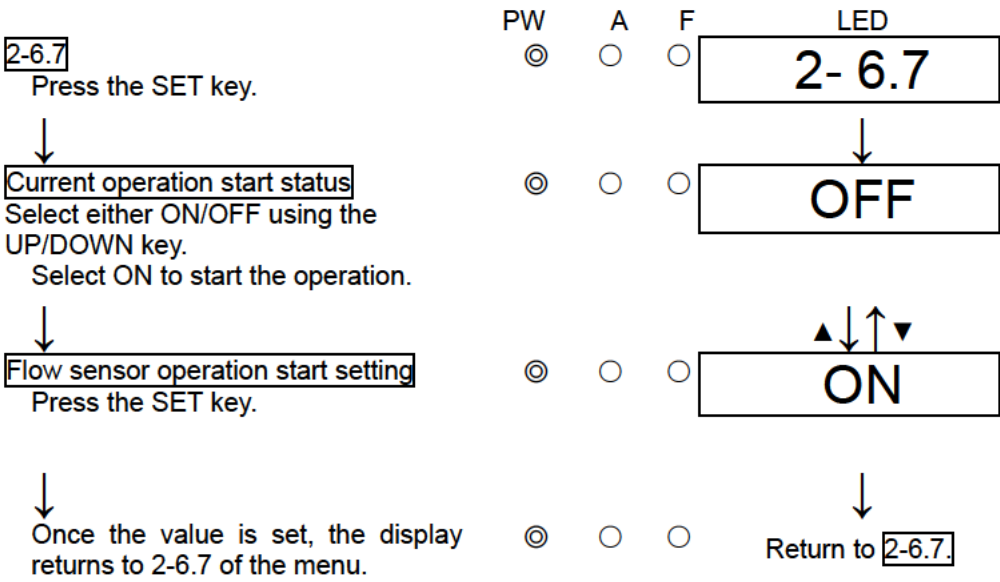

7-4. How to maintain flow sensor

Remove the pump.



2-6.3 Flow sensor zero point check
Press the SET key.



Flow sensor zero point check completed

It automatically returns to 2-6.3 after PASS is displayed.

* If the zero point check of the flow sensor fails, it automatically returns to 2-6.3 after FAIL is displayed.



Install the test pump.



2-6.4 Flow sensor output check
Check the flow sensor output during the pump operation.



Flow sensor output check completed

It automatically returns to 2-6.4 after PASS is displayed.

* If the output check of the flow sensor failed, it automatically returns to 2-6.4 after FAIL is displayed.

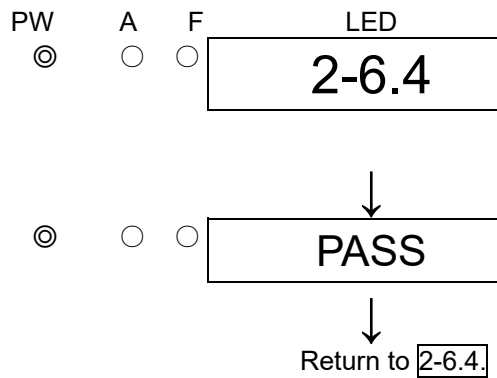
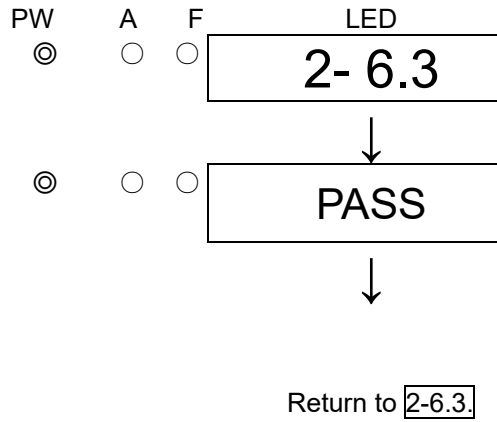

7-5. Parts replacement

<Flow Sensor Replacement>

To replace the flow sensor, use the following procedure.

1. Turn off the power supply.
2. Open the cover of the drive unit and remove the sensor cap. (Use a hexagonal wrench (nominal 4).

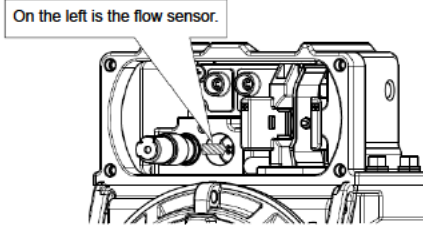

3. Remove the sensor and insert the new sensor. Insert the sensor with the longest pin facing right. Record the symbols (A, b, c, d, and E) printed on the sensor to be replaced.

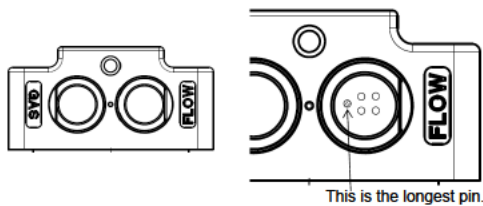

4. After installing the sensor, attach the sensor cap and tighten the hexagon socket bolt.

NOTE

Adjustment is required after the flow sensor or pump is replaced. Please contact RIKEN KEIKI. As a guide, replace the sensors of the pump unit with new ones every one to three years.

<Replacement of Regular Replacement Parts>

List of recommended regular replacement parts

Name	Maintenance intervals	Replacement intervals (year)	Quantity (pieces/unit)	Remarks
AC/DC converter	6 months	3 - 6 years	1	※
Flow sensor	6 months	2 years	1	※
Tubes	6 months	3 - 8 years	1	※
Pump unit	6 months	1 - 2 years	1	※
Chamber assembly	6 months	3 - 8 years	1	※
Sensor cap assembly	6 months	3 - 8 years	1	※

※After the part is replaced, the operation must be checked by a qualified service engineer.

For the stable operation of the detector and safety, ask a qualified service engineer to take care of replacement of the parts whose operation must be checked. Please contact our sales department.

NOTE

The above replacement intervals are recommendation only. The intervals may change depending on the conditions such as the operating environment. These intervals do not mean the warranty periods either. The result of the regular maintenance may determine when to replace the parts.

8

Storage, Relocation and Disposal

8-1. Procedures to store the pump unit or leave it for a long time

The pump unit or must be stored under the following environmental conditions.

- In a dark place under the normal temperature and humidity away from direct sunlight
- In a place where gases, solvents or vapors are not present

8-2. Procedures to relocate the pump unit or use it again

When the pump unit is relocated, select a new place in accordance with "4-2. Precautions for installation points" and "4-4. How to install".

For information on wiring, see "4-5. How to wire". The unpowered time must be minimized when the pump unit is relocated.



CAUTION

When using a relocated or stopped/stored pump unit again, do not forget to perform a check.
For information on check, please contact RIKEN KEIKI.

8-3. Disposal of products

When the pump unit is disposed of, it must be treated properly as an industrial waste in accordance with the local regulations.

9

Troubleshooting

The Troubleshooting does not explain the causes of all the malfunctions which occur on the pump unit. This simply helps to find the causes of malfunctions which frequently occur. If the pump unit shows a symptom which is not explained in this manual, or still has malfunctions even though remedial actions are taken, please contact RIKEN KEIKI.

<Abnormalities on Unit>

Symptom/Display	FAULT	Causes	Actions
<u>The power cannot be turned on.</u>	—	The wiring is not correct.	Connect the wiring properly.
		The terminal plate is removed.	Connect the terminal plate properly.
		Abnormalities/momentary blackout of power supply system	Provide the rated voltage. Take measures such as checking or adding the UPS, power supply line filter and insulation transformer.
		Cable abnormalities (open circuit/not connected/short circuit)	Check the wiring of pump unit and related devices around it.
<u>Abnormal operations</u>	—	Disturbances by sudden surge noise, etc.	Turn off and restart the pump unit. If such a symptom is observed frequently, take appropriate measures to eliminate the noise.
<u>Low flow rate abnormality</u> E-5	●	The flow rate is low.	The possible causes are deterioration or clogging of the pump or clogging of the tube. Check the flow rate.
		Faults of the flow sensor	Replace the sensor with a new one.
<u>System abnormalities</u> E-9	●	Abnormalities of ROM, RAM, or EEPROM inside of the pump unit	Please contact RIKEN KEIKI.

10

Product Specifications

10-1. List of specifications

[RP-D58•DC] <ATEX/UKEX Specifications >

Model	RP-D58 · DC
Display	Seven-segment LED(four-digit)
Flow rate	1.0 L/min or more (at maximum suction pressure of 5.0 kPa <gauge pressure>)
Power display	POWER lamp on (green)
External output	Fault alarm contact
Fault alarm/self diagnosis	System abnormality/low flow rate
Fault alarm display	FAULT lamp on (yellow)/detail display
Fault alarm pattern	Non latching (Auto-reset)
Fault alarm contact	No-voltage contact 1a, de-energized (energized in response to an alarm) or energized (de-energized in response to an alarm)
Contact capacity	30 VDC - 0.5A (resistant load)
Power/contact cable	CVVS, etc. (1.25mm ² or 2.0mm ²) – 2-core or 4-core
Transmission distance	Less than 375m in case of CVV 1.25mm ² Less than 550m in case of CVV 2.0mm ²
Initial clear	Approx.25sec
Power supply	24VDC±10%
Power consumption	Maximum 8.6W
Cable connecting port	Pressure proof packing gland<G3/4> (Compatible cables φ9.0 - φ16.0mm in outer diameter)
Tube connecting port	Rc1/8 (O.Dφ8-1t half-union for Cu tube <Bs> supplied or half-union for SUS tube <SUS>)
Operating temperature	-20 - +53°C (non-rapidly-vary)
Operating humidity	Below 95% RH (Non-condensing)
Structure	Wall mounting type (2B<50A> pipe installation supported)
Explosion-proof structure	Flame-proof enclosures
Explosion-proof class	II 2G Ex db h II B+H2 T4 Gb
IP rating	Equivalent to IP67
Dimension	Approx. 197 (W) x 292 (H) x 140 (D) mm (projection portions excluded)
Weight	Approx. 5.8 kg
Outer color	Munsell 7.5BG5/2

* Specifications subject to changes without notice.

[RP-D58•AC]<Taiwan Ex(TS) Specifications >

Model	RP-D58 · AC
Display	Seven-segment LED(four-digit)
Flow rate	1.5 L/min or more (at maximum suction pressure of 5.3 kPa <gauge pressure>)
Power display	POWER lamp on (green)
External output	Fault alarm contact
Fault alarm/self diagnosis	System abnormality/low flow rate
Fault alarm display	FAULT lamp on (yellow)/detail display
Fault alarm pattern	Non latching (Auto-reset)
Fault alarm contact	No-voltage contact 1a, de-energized (energized in response to an alarm) or energized (de-energized in response to an alarm)
Contact capacity	250 VAC - 0.5 A/30 VDC - 0.5A (resistant load)
Power cable	CVV, etc. (1.25mm ² or 2.0mm ²) – 2-core or 3-core
Transmission distance	Less than 1.25km in case of Cable 1.25mm ² Less than 2.0km in case of Cable 2.0mm ²
Contact cable	CVVS, etc. (1.25mm ² or 2.0mm ²) · 2-core
Initial clear	Approx. 25sec
Power supply	100 - 110 VAC ±10%, 50/60 Hz
Power consumption	Maximum 13 VA
Cable connecting port	Pressure proof packing gland<G3/4>(Compatible cables φ9.0 - φ16.0mm in outer diameter)
Tube connecting port	Rc1/8 (O.Dφ8-1t half-union for Cu tube <Bs> supplied or half-union for SUS tube <SUS>)
Operating temperature	-20 - +50°C (non-rapidly-vary)
Operating humidity	Below 95% RH (Non-condensing)
Structure	Wall mounting type (2B<50A> pipe installation supported)
Explosion-proof structure	Flame-proof enclosures
Explosion-proof class	Ex d II B+H2 T4 Gb
IP rating	Equivalent to IP67
Dimension	Approx. 197 (W) x 292 (H) x 140 (D) mm (projection portions excluded)
Weight	Approx. 5.8 kg
Outer color	Munsell 7.5BG5/2

* Specifications subject to changes without notice.

[RP-D58•DC]<Taiwan Ex(TS) Specifications>

Model	RP-D58 · DC
Display	Seven-segment LED(four-digit)
Flow rate	1.0 L/min or more (at maximum suction pressure of 5.0 kPa <gauge pressure>)
Power display	POWER lamp on (green)
External output	Fault alarm contact
Fault alarm/self diagnosis	System abnormality/low flow rate
Fault alarm display	FAULT lamp on (yellow)/detail display
Fault alarm pattern	Non latching (Auto-reset)
Fault alarm contact	No-voltage contact 1a, de-energized (energized in response to an alarm) or energized (de-energized in response to an alarm)
Contact capacity	250 VAC - 0.5 A/30 VDC - 0.5A (resistant load)
Power/contact cable	CVVS, etc. (1.25mm ² or 2.0mm ²) – 2-core or 4-core
Transmission distance	Less than 375m in case of CVV 1.25mm ² Less than 550m in case of CVV 2.0mm ²
Initial clear	Approx.25sec
Power supply	24VDC±10%
Power consumption	Maximum 8.6W
Cable connecting port	Pressure proof packing gland<G3/4>(Compatible cables φ9.0 - φ16.0mm in outer diameter)
Tube connecting port	Rc1/8 (O.Dφ8-1t half-union for Cu tube <Bs> supplied or half-union for SUS tube <SUS>)
Operating temperature	-20 - +53°C (non-rapidly-vary)
Operating humidity	Below 95% RH (Non-condensing)
Structure	Wall mounting type (2B<50A> pipe installation supported)
Explosion-proof structure	Flame-proof enclosures
Explosion-proof class	Ex d II B+H2 T4 Gb
IP rating	Equivalent to IP67
Dimension	Approx. 197 (W) x 292 (H) x 140 (D) mm (projection portions excluded)
Weight	Approx. 5.8 kg
Outer color	Munsell 7.5BG5/2

* Specifications subject to changes without notice.

[RP-D58•AC]<Japan Ex Specifications>

Model	RP-D58 · AC
Display	Seven-segment LED(four-digit)
Flow rate	1.5 L/min or more (at maximum suction pressure of 5.3 kPa <gauge pressure>)
Power display	POWER lamp on (green)
External output	Fault alarm contact
Fault alarm/self diagnosis	System abnormality/low flow rate
Fault alarm display	FAULT lamp on (yellow)/detail display
Fault alarm pattern	Non latching (Auto-reset)
Fault alarm contact	No-voltage contact 1a, de-energized (energized in response to an alarm) or energized (de-energized in response to an alarm)
Contact capacity	250 VAC - 0.5 A/30 VDC - 0.5A (resistant load)
Power cable	CVV, etc. (1.25mm ² or 2.0mm ²) – 2-core or 3-core
Transmission distance	Less than 1.25km in case of Cable 1.25mm ² Less than 2.0km in case of Cable 2.0mm ²
Contact cable	CVVS, etc. (1.25mm ² or 2.0mm ²) · 2-core
Initial clear	Approx. 25sec
Power supply	100 - 110 VAC ±10%, 50/60 Hz
Power consumption	Maximum 13 VA
Cable connecting port	Pressure proof packing gland<G3/4>(Compatible cables φ9.0mm - in outer diameter)
Tube connecting port	Rc1/8 (O.Dφ8-1t half-union for Cu tube <Bs> supplied or half-union for SUS tube <SUS>)
Operating temperature	-20 - +50°C (non-rapidly-vary)
Operating humidity	Below 95% RH (Non-condensing)
Structure	Wall mounting type (2B<50A> pipe installation supported)
Explosion-proof structure	Flame-proof enclosures
Explosion-proof class	Ex d II B+H2 T4
IP rating	Equivalent to IP67
Dimension	Approx. 197 (W) x 292 (H) x 140 (D) mm (projection portions excluded)
Weight	Approx. 5.8 kg
Outer color	Munsell 7.5BG5/2

* Specifications subject to changes without notice.

[RP-D58•DC]<Japan Ex Specifications>

Model	RP-D58 · DC
Display	Seven-segment LED(four-digit)
Flow rate	1.0 L/min or more (at maximum suction pressure of 5.0 kPa <gauge pressure>)
Power display	POWER lamp on (green)
External output	Fault alarm contact
Fault alarm/self diagnosis	System abnormality/low flow rate
Fault alarm display	FAULT lamp on (yellow)/detail display
Fault alarm pattern	Non latching (Auto-reset)
Fault alarm contact	No-voltage contact 1a, de-energized (energized in response to an alarm) or energized (de-energized in response to an alarm)
Contact capacity	250 VAC - 0.5 A/30 VDC - 0.5A (resistant load)
Power/contact cable	CVVS, etc. (1.25mm ² or 2.0mm ²) – 2-core or 4-core
Transmission distance	Less than 375m in case of CVV 1.25mm ² Less than 550m in case of CVV 2.0mm ²
Initial clear	Approx.25sec
Power supply	24VDC±10%
Power consumption	Maximum 8.6W
Cable connecting port	Pressure proof packing gland<G3/4>(Compatible cables φ9.0mm - in outer diameter)
Tube connecting port	Rc1/8 (O.Dφ8-1t half-union for Cu tube <Bs> supplied or half-union for SUS tube <SUS>)
Operating temperature	-20 - +53°C (non-rapidly-vary)
Operating humidity	Below 95% RH (Non-condensing)
Structure	Wall mounting type (2B<50A> pipe installation supported)
Explosion-proof structure	Flame-proof enclosures
Explosion-proof class	Ex d II B+H2 T4
IP rating	Equivalent to IP67
Dimension	Approx. 197 (W) x 292 (H) x 140 (D) mm (projection portions excluded)
Weight	Approx. 5.8 kg
Outer color	Munsell 7.5BG5/2

* Specifications subject to changes without notice.

10-2. Detection principle

[Flow Sensor]

The flow sensor has a circuit that can output a contact signal when the flow rate drops below the preset level.

The flow sensor is a hot-wire type with a Wheatstone bridge consisting of a detecting element, compensating element, and fixed resistance. Contained in a flame arrester container allows it to be flame-proof.

When the drawn air or gas comes into contact with the heated detecting element, the detecting element temperature changes due to the heat dissipation, and the electrical resistance of the element changes according to the temperature changes. Since the resistance changes are in proportion to the gas flow rates, the Wheatstone bridge circuit can identify the changes as the flow rate.

Structure Diagram

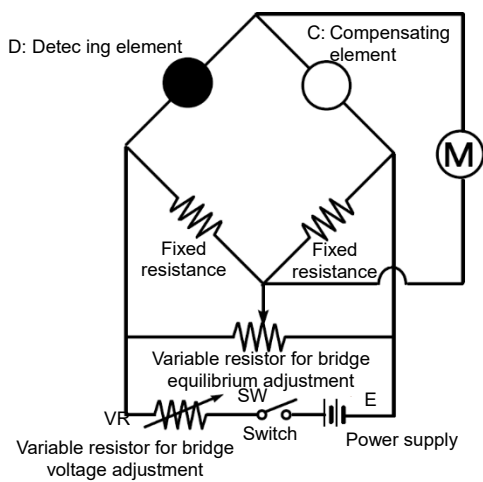

Basic Circuit

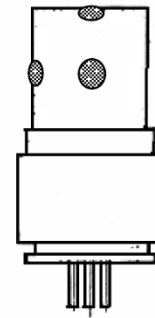

Flow Sensor Appearance



EU-Declaration of Conformity

Document No.: 320CE22079



We, RIKEN KEIKI Co., Ltd. 2-7-6, Azusawa, Itabashi-ku, Tokyo, 174-8744 Japan declare under our sole responsibility that the following product conforms to all the relevant provisions.

Product Name	Model
Combustible Gas Detector Head	GD-D58·DC, GD-D58·DC·GH
Smart Transmitter / Gas Detector Head	SD-D58·DC, SD-D58·DC·GH
Fixed type Explosion-Proof Pump Unit	RP-D58·DC

Council Directives		Applicable Standards
2014/34/EU	ATEX Directive	EN IEC 60079-0:2018, EN 60079-1:2014, EN ISO 80079-36:2016, EN ISO 80079-37:2016
2014/30/EU	EMC Directive	EN 50270:2015
2011/65/EU ^[1]	RoHS Directive	EN IEC 63000:2018

^[1]Including substances added by Commission Delegated Directive (EU) 2015/863

EU-Type examination Certificate No.: DNV 21 ATEX 63457X

Notified Body for ATEX DNV Product Assurance AS (NB 2460)
Veritasveien 1
1363 Høvik
Norway

Auditing Organization for ATEX DNV Product Assurance AS (NB 2460)
Veritasveien 1
1363 Høvik
Norway

The marking of the product shall include the following:

 II 2 G Ex db h IIB+H2 T4 Gb

Place: Tokyo, Japan

Date: Jun. 29, 2022

Takakura Toshiyuki
General manager
Quality Control Center



UK-Declaration of Conformity

Document No.: 320UK22044



We, RIKEN KEIKI Co., Ltd. 2-7-6, Azusawa, Itabashi-ku, Tokyo, 174-8744, Japan declare under our sole responsibility that the following product conforms to all the relevant provisions.

Product Name	Model
Combustible Gas Detector Head	GD-D58·DC, GD-D58·DC·GH
Smart Transmitter / Gas Detector Head	SD-D58·DC, SD-D58·DC·GH
Fixed type Explosion-Proof Pump Unit	RP-D58·DC

Regulations	UK designated Standards
Electromagnetic Compatibility Regulations 2016 (S.I. 2016/1091)	BS EN 50270:2015
The Equipment and Protective Systems Intended for Use in Potentially Explosive Atmospheres Regulations 2016 (S.I. 2016/1107) (UKEX)	BS EN IEC 60079-0:2018 BS EN 60079-1:2014 BS EN ISO 80079-36:2016 BS EN ISO 80079-37:2016
The Restriction of the Use of Certain Hazardous Substances in Electrical and Electronic Equipment Regulations 2012 (S.I. 2012/3032)	BS EN IEC 63000:2018

UK-Type examination Certificate No.

DNV 22 UKEX 25926X

Approved Body for UKEX

DNV Business Assurance UK Ltd (AB8501)
4th Floor Vivo Building, 30 Stamford Street,
London SE1 9LQ, United Kingdom

Auditing Organization for UKEX

DNV Business Assurance UK Ltd (AB8501)
4th Floor Vivo Building, 30 Stamford Street,
London SE1 9LQ, United Kingdom

The marking of the product shall include the following:

 II 2 G Ex db h IIB+H2 T4 Gb -20°C≤Ta≤+53°C

Place: Tokyo, Japan

Date: Nov. 18, 2022

Takakura Toshiyuki
General manager
Quality Control Center