



PT9E-0075

# **Pyrolyzer Unit**

**(for GD-70D Series)**

## **PLU-70**

**Operating Manual**

**RIKEN KEIKI Co., Ltd.**

2-7-6 Azusawa, Itabashi-ku, Tokyo, 174-8744, Japan

Phone : +81-3-3966-1113

Fax : +81-3-3558-9110

E-mail : [intdept@rikenkeiki.co.jp](mailto:intdept@rikenkeiki.co.jp)

Web site : <https://www.rikenkeiki.co.jp/>

## Preface

Thank you for choosing the pyrolyzer unit PLU-70 designed for dedicated use with our gas detector head GD-70D series. Please check that the model number of the product you purchased is included in the specifications on this manual.

This pyrolyzer unit is designed for dedicated use with the gas detector head GD-70D series and must be used in combination with the GD-70D series as the base unit.

This operating manual explains how to use the pyrolyzer unit PLU-70 installed on the gas detector head. The basic operating procedures conform to those of the base unit, GD-70D series. This operating manual is intended as a complement to the GD-70D series operating manual.



For proper use of the pyrolyzer unit, please read and thoroughly understand both this operating manual and the GD-70D series operating manual before use.

## <Contents>

	Preface .....	2
	Important Notices on Safety .....	4
	Method of confirmation for CE marking type .....	5
1.	Overview .....	6
1-1.	Product components.....	6
1-2.	Product specifications.....	7
1-3.	List of accessories.....	7
1-4.	Names and functions for each part.....	8
1-5.	Block diagram.....	10
2.	Installation .....	11
2-1.	Requirements .....	11
2-2.	Installation of pyrolyzer unit.....	12
2-3.	How to wire.....	16
2-4.	How to tube .....	18
2-5.	Relocate .....	19
2-6.	Disposal.....	19
3.	How to Operate .....	20
3-1.	Preparation for start-up.....	20
3-2.	How to start the pyrolyzer unit.....	20
3-3.	How to exit.....	21
4.	Regular Maintenance Mode .....	22
5.	Maintenance.....	24
5-1.	Gas calibration method.....	24
5-2.	Other adjustments/Cleaning method .....	25
5-3.	How to replace parts.....	25
5-4.	Procedures to store the pyrolyzer unit or leave it for a long time.....	25
6.	Troubleshooting.....	26

# Important Notices on Safety

## <Definition of DANGER, WARNING, CAUTION, and NOTE>

 <b>DANGER</b>	Indicates an imminently hazardous situation which, if not avoided, will result in death or serious injury or serious damage to the product. The use of this symbol is to be limited to the most extreme situation.
 <b>WARNING</b>	Indicates a potentially hazardous situation which, if not avoided, could result in death or serious injury on the human body or object.
 <b>CAUTION</b>	Indicates a potentially hazardous situation which, if not avoided, may result in minor or moderate injury or some damage on the human body or objects. It may also be used to alert against unsafe practices.
<b>NOTE</b>	This means "ADVICE" at operation.

## <Danger Cases>

 <b>DANGER</b>
This is not an explosion-proof unit. You must not use it to detect gases exceeding the lower explosive limit (LEL).

## <Warning Cases>

 <b>WARNING</b>
<p><b>Power Supply</b> Before turning on the pyrolyzer unit, always check that the voltage is properly applied. Do not use an unstable power supply because it may cause malfunctions.</p> <p><b>Need of grounding circuit</b> Do not cut the grounding circuit inside or outside the pyrolyzer unit or disconnect the wire from the grounding terminal.</p> <p><b>Tubing</b> The pyrolyzer unit and the base unit, gas detector head, are designed to draw gases around them under the atmospheric pressure. If excessive pressure is applied to the sampling inlet and outlet (GAS IN, GAS OUT), detected gases may be leaked from its inside, thus leading to dangers. Be sure that excessive pressure is not applied to the pyrolyzer unit and the gas detector head while used. Detected gases must be exhausted from the detected gas exhausting outlet (GAS OUT) on the bottom of the gas detector head to which an exhaust tube is connected, to a point regarded as a safe place.</p> <p><b>Operation in a gas</b> Do not operate the pyrolyzer unit in a place where combustible gases or vapors are present. Operating the pyrolyzer unit in such an environment will lead to extreme dangers.</p> <p><b>Pyrolyzer heater (pyrolyzer)</b> The pyrolyzer heater becomes hot. Do not touch the pyrolyzer heater because your hands may be burnt. Do not touch the pyrolyzer heater just after power-off because it is still hot.</p>

## <Precautions>



### CAUTION

**Do not use a transceiver (walkie-talkie) near the pyrolyzer unit.**

Radio wave from a transceiver near the pyrolyzer unit or its cables may affect reading. When using a transceiver, it must be used in a place where it disturbs nothing.

**To restart the pyrolyzer unit, you must wait five seconds more before doing it.**

Restarting the pyrolyzer unit within five seconds may cause errors.

**Attach the dust filter before using the pyrolyzer unit.**

Before using the pyrolyzer unit, attach the specified filter to prevent disturbances by possible gas adsorption or air dust.

A dust filter to be used varies depending on the gas to be detected. For more information on dust filters, please contact our sales department.

**Observe the operating restrictions to prevent condensation inside the tube.**

Condensation formed inside the tube causes clogging or gas adsorption, which may disturb accurate gas detection. Thus, condensation must be avoided. In addition to the installation environment, carefully monitor the temperature/humidity of the sampling point to prevent condensation inside the tube. In particular, when detecting a gas which is dissolved into water and corrodes contacted materials, such as a strong acid gas, the gas is undetectable and furthermore may corrode internal parts. Please observe the operating restrictions.

**Do not disassemble/modify the pyrolyzer unit, or change the settings if not necessary.**

Disassembling/Modifying the pyrolyzer unit will invalidate the warranty of the performance. Changing the settings without understanding the specifications may cause alarm malfunctions. Please use the pyrolyzer unit properly in accordance with the operating manual.

**Do not forget to perform a regular maintenance.**

Since this is a safety unit, a regular maintenance must be performed to ensure its safety. Continuing to use the pyrolyzer unit without performing a maintenance will compromise the sensitivity of the sensor, thus resulting in inaccurate gas detection.

## Method of confirmation for CE marking type

The CE marking is labeled on the detector in case of comply with CE marking. Please confirm the instrument specification before using. Please refer Declaration of Conformity that is at the end of this manual if you have CE marking type.

You can confirm instrument specification to see the CE marking as follows.

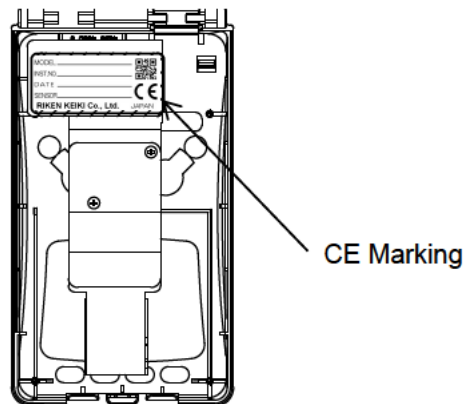

CE marking label (Back of front cover)

---

# 1

---

## Overview

### 1-1. Product components

<Pyrolyzer Unit (PLU-70)>

<Standard Accessories>

- Operating manual
- Protective rubber cap (to be removed when using the pyrolyzer unit)
- Dedicated handling lever (for wiring)
- Dedicated U-tube



<Gas Detector Head GD-70D Series (Base Unit: Option)>

\* This pyrolyzer unit is designed for dedicated use with the gas detector head GD-70D series. Use the pyrolyzer only after installation on the base unit, GD-70D series.

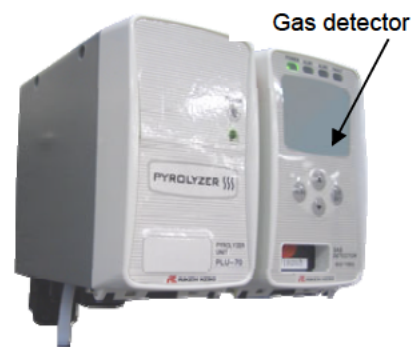

## 1-2. Product specifications

Power Display	POWER lamp on (green)
Recommended Power Cable	Cable of CVV, etc.(1.25sq) - 2-core
Power Supply	24VDC $\pm$ 10%
Power consumption	Max. 25 W
Tube Connecting Hole	Rc1/4 (O.D $\Phi$ 6-1t half-union for Teflon tube<PP>supplied)
Operating temperature	0-40°C (at a constant condition)
Operating humidity	30-80%RH (Non-condensing)
Structure	Box type/Wall mounted type
External Dimensions	Approx. 70(W)x120(H)x145(D) mm (projection portions excluded)
Weight	Approx. 0.9 kg
Outer Color	PLU main unit: grey Front door: white

## 1-3. List of accessories

- Operating manual
- Protective rubber cap
- Dedicated handling lever
- Dedicated U-tube

# 1-4. Names and functions for each part

## <Appearance>

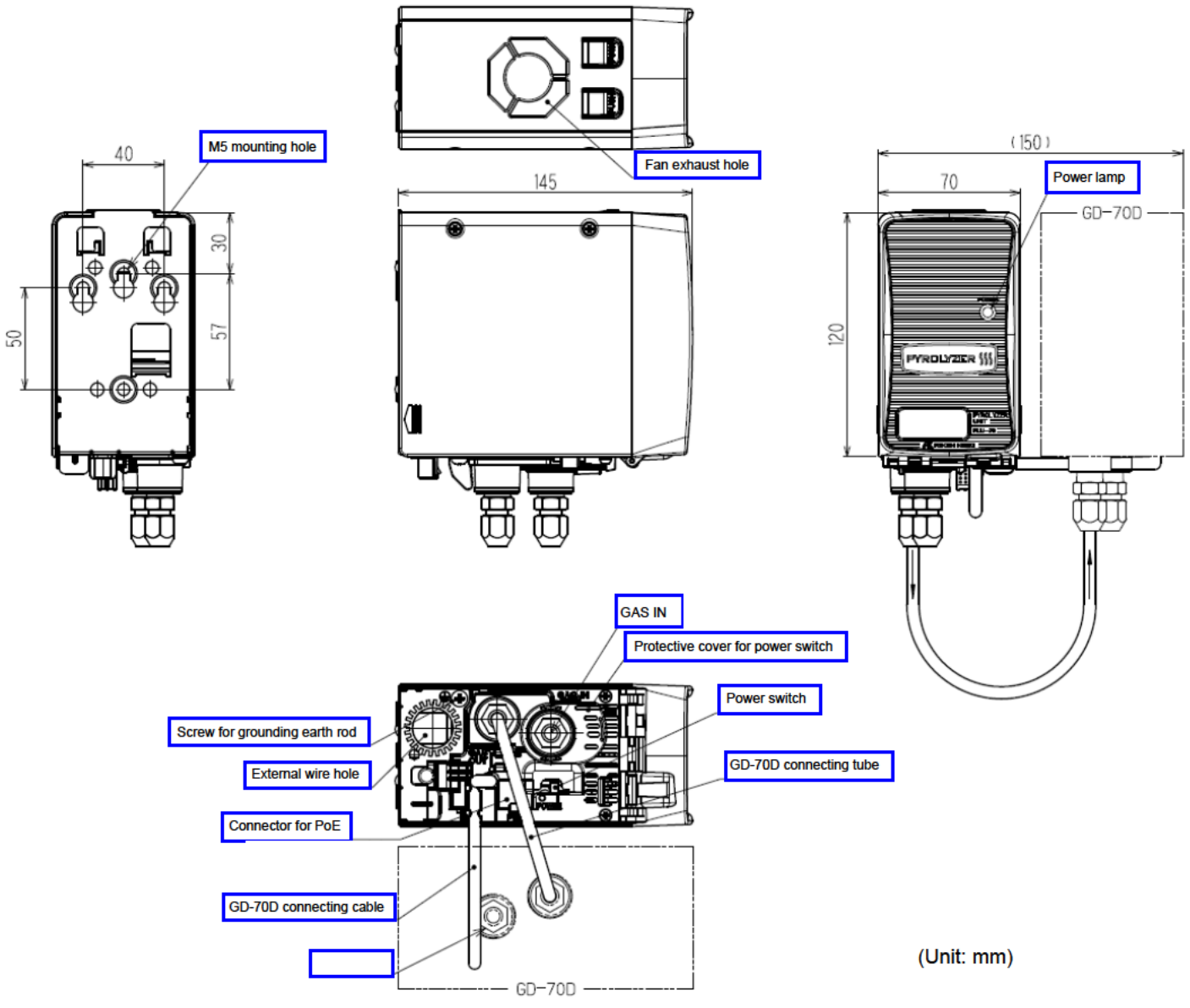

(Unit: mm)



## <Components of the Pyrolyzer Unit>

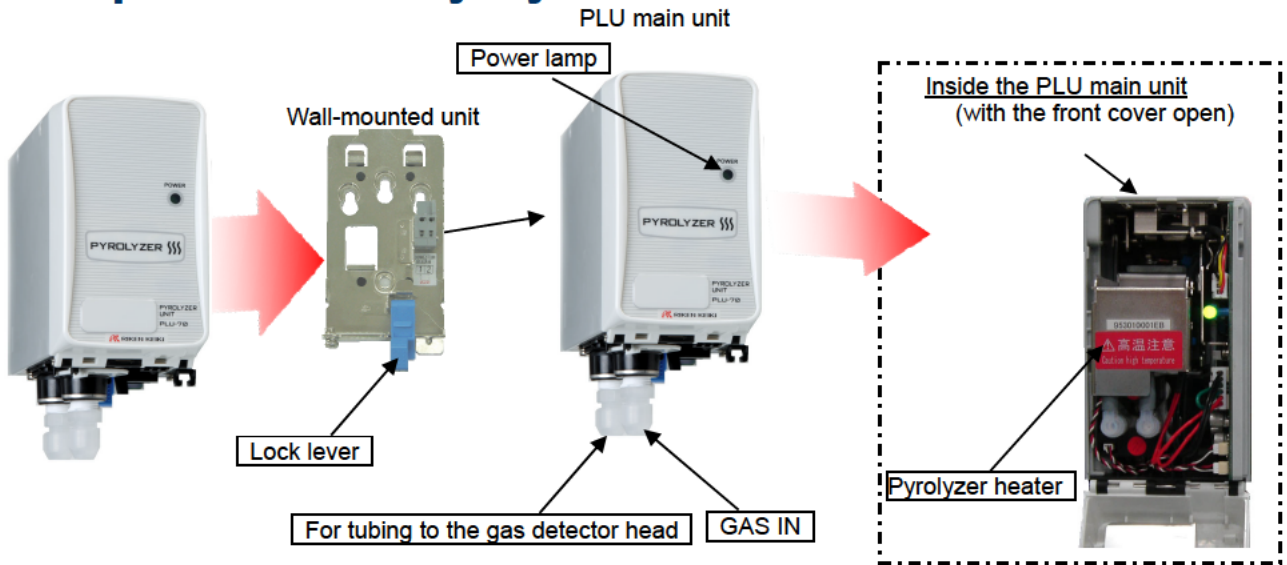

### CAUTION

- Each unit consists of precision parts. When a unit is detached, be careful not to drop it. Dropping the unit compromises its original performance or causes malfunctions.

## <Wall-mounted Unit>

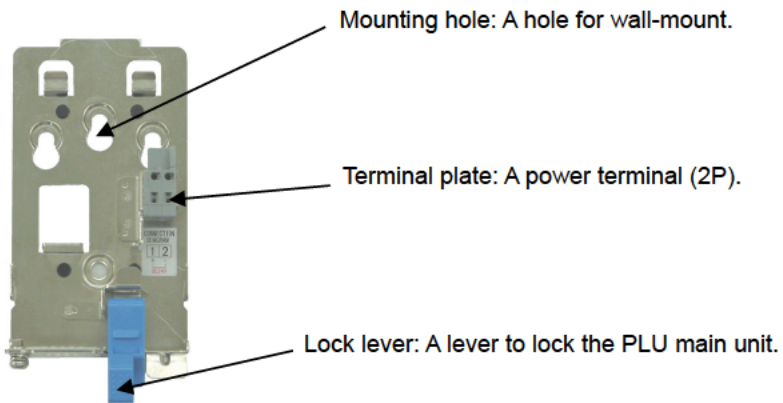

# 1-5. Block diagram

## <Electric Diagram>

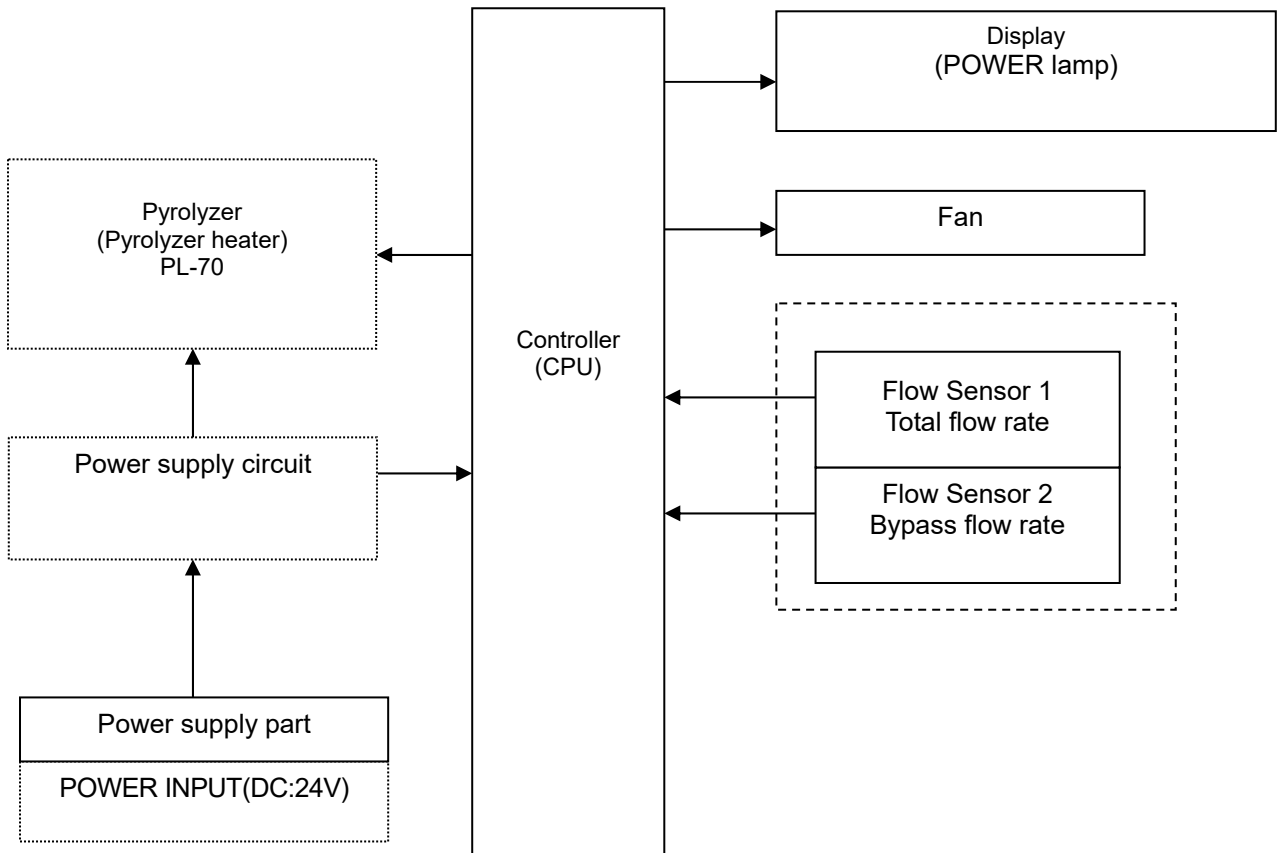

## <Tubing Diagram>

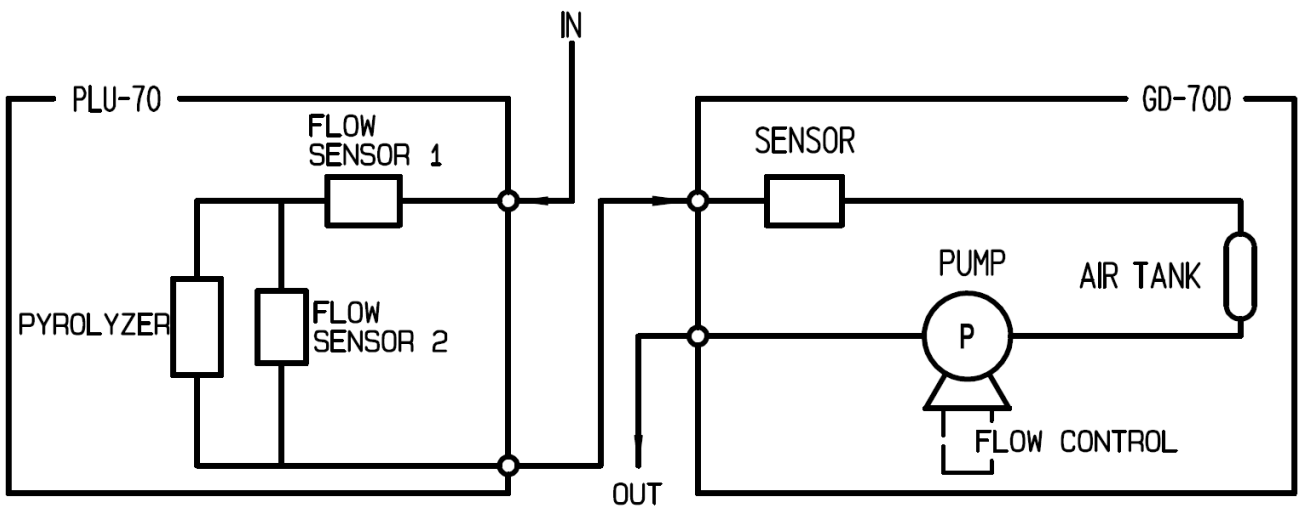

---

## 2

---

# Installation

## 2-1. Requirements

Not only the first-time users but also the users who have already used the product must follow the operating precautions.

Ignoring the precautions may damage the pyrolyzer unit, resulting in inaccurate gas detection.



### CAUTION

- After you receive the pyrolyzer unit, start using the pyrolyzer immediately.

### <Precautions for Installation Sites>



- Install the pyrolyzer unit near the base unit, gas detector head GD-70D series. Since the pyrolyzer unit is a precision device like the gas detector head, the precautions for installation sites shall conform to those of the gas detector head. (See the operating manual for the GD-70D series.)

### < Precautions for System Designing >



- An unstable power supply and noise may cause malfunctions or false alarms.
- The designing of a system using the pyrolyzer unit must reflect the contents of the operating manual of the base unit, gas detector head GD-70D series, and the descriptions in this section.

### Using a stable power supply

The pyrolyzer unit must be provided with the following power supply.

Power supply voltage	24 VDC $\pm$ 10% (the terminal voltage of the pyrolyzer unit)
Allowed time of momentary blackout	Up to 10 millisecond (To recover from the momentary blackout for 10 milliseconds or more, restart the pyrolyzer unit.) To ensure continuous operation and activation, install a UPS outside the pyrolyzer unit.
Others	Do not use it with a power supply of large power load or high-frequency noise. Use a line filter to avoid the noise source if necessary.

### Heat radiation designing

- Do not block the ventilation holes when you install the pyrolyzer unit on or under the gas detector head. It is recommended that installation points of the sets should be away from each other for 10 mm or more. Intervals between installation points must be at least 5 mm.
- When it is installed in the closed instrumentation board, attach ventilation fans above and below the board.



#### CAUTION

- When the internal temperature of the pyrolyzer unit reaches about 60°C, a trouble alarm is issued by the gas detector head, resulting in a halt of the pyrolyzer heater. Since the internal temperature rises to ten-odd degrees higher than the ambient temperature, take care not to let the ambient temperature exceed 40°C. Provide a clearance of 30 mm or more above the pyrolyzer unit to prevent a rise in the internal temperature.

## 2-2. Installation of pyrolyzer unit



#### CAUTION

- Install the pyrolyzer unit near the base unit, gas detector head GD-70D series. See the descriptions in this section and the gas detector head GD-70D series operating manual before carrying out installation.
- Before installing the pyrolyzer unit, remove the protective rubber caps from GAS IN and GAS OUT. If the pyrolyzer unit turned on with the rubber caps remaining while the installation, applied overload may damage the pump and sensor. Do not forget to remove the caps.

## <Install Dimension and Maintenance Space>

Leave the diagonal line area so that the installation space is reserved.

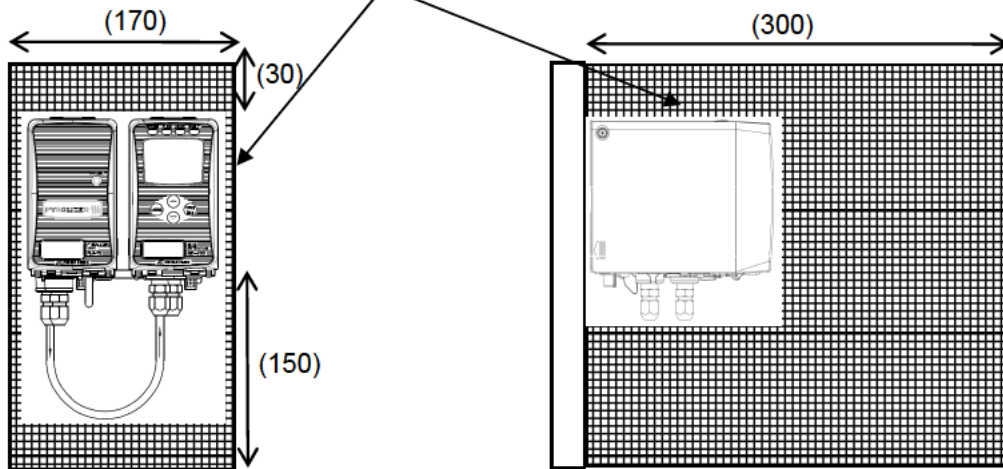

When installing by using 2 screws

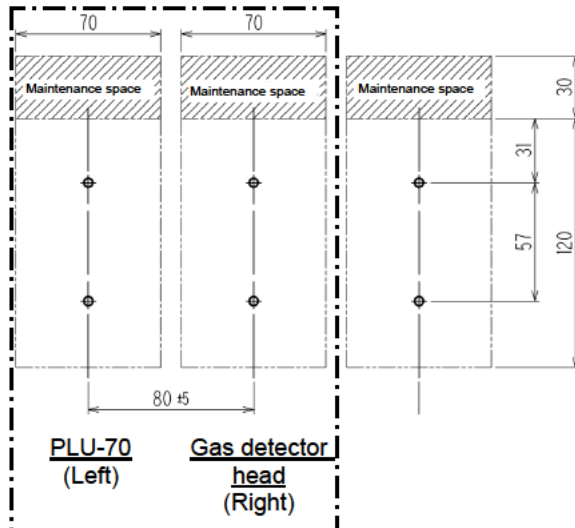

talling by using 3 screws

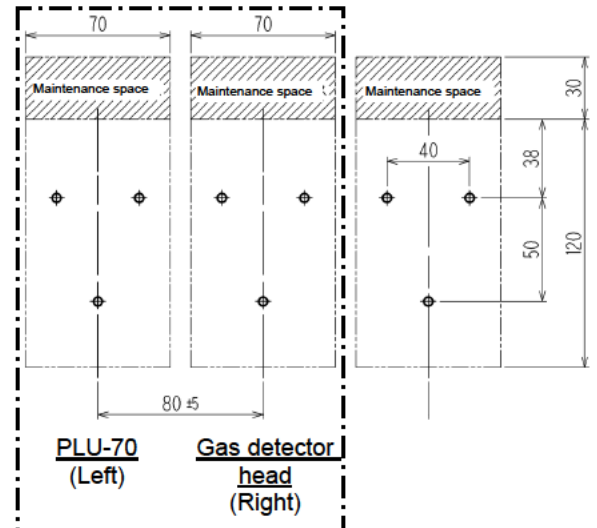

(Unit: mm)



### CAUTION

- The installation points of the pyrolyzer unit PLU-70 and the gas detector head GD-70D series should be away from each other for  $80 \pm 5$  mm (with a clearance of 5 to 15 mm). It is recommended that installation points of the sets should be away from each other for 10 mm or more. Intervals between installation points must be at least 5 mm.
- The PLU-70 must be installed on the LEFT of the gas detector head GD-70D series.

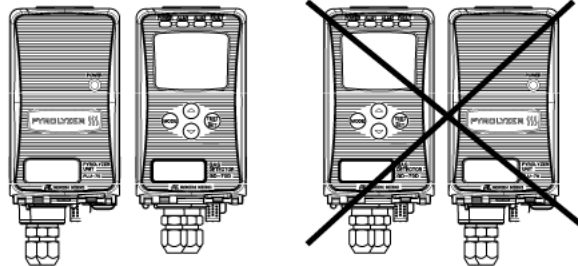

## <Installation of Wall-mounted Unit>

Attach the wall-mounted unit in the installation surface using two or three M5 screws.

Recommended mounting screw  
Length of 8 mm or more  
Flat washer of  $\Phi 10$  mm or less (small round)

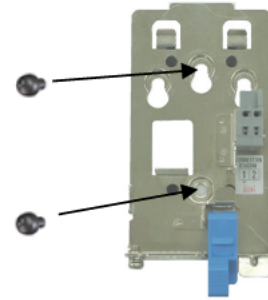

After the wall-mounted unit is attached to the wall, install the PLU main unit on the wall-mounted unit.



### CAUTION

- Install the unit so that its surface is in intimate contact with the wall-mounted unit. A space between the unit and the wall-mounted unit may invite unnecessary vibrations and noises.

## <Detaching and Attaching PLU Main Unit>

### Attaching PLU Main Unit

At the position of 10 mm above the wall-mounted unit, press the PLU main unit onto the wall-mounted unit. Be sure to fit both side hooks of the wall-mounted unit in the grooves of the PLU main unit.

Then press down the PLU main unit to fix it. The lock at the bottom of the PLU main unit clicks to fix it properly. Make sure that the top center of the wall-mounted unit is above the PLU main unit as viewed from front.

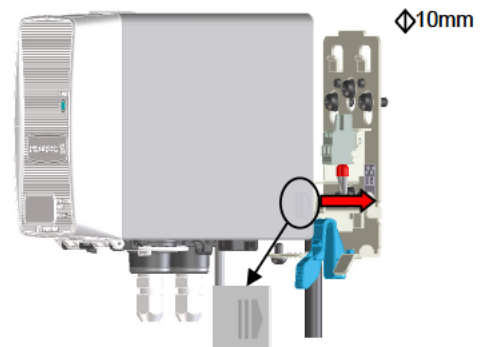

When pressing the PLU main unit, align the side mark with the hook of the wall-mounted unit for smooth installation.

Make sure that the top of the wall-mounted unit is above the PLU main unit.

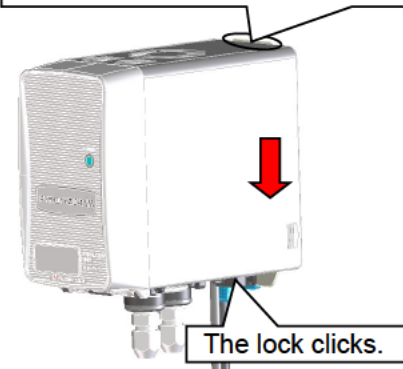

### Detaching PLU Main Unit

While pushing the sky blue lever toward the wall-mounted unit, hold up the PLU main unit.

If you cannot move the PLU main unit, insert a larger flathead screwdriver while pushing the lever, and you can easily detach it as shown below. Do not rotate or move up and down the flathead screwdriver. Simply insert it into the wall-mounted unit.



#### CAUTION

- Be careful not to drop the PLU main unit when detaching it. Also, check the secure installation of the PLU main unit after attaching it to the wall-mounted unit. If the PLU main unit is not securely installed, it might fall, causing an unexpected injury or a damage of the unit.
- Turn the power off before detaching or attaching the PLU main unit.

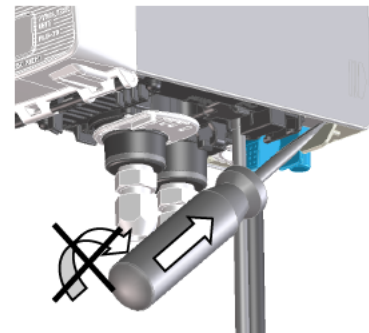
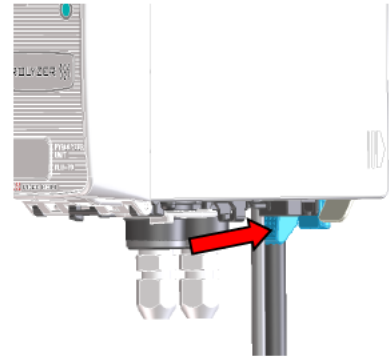

## 2-3. How to wire



### CAUTION

- Be careful not to mistake the wall-mounted unit of the pyrolyzer unit with that of the gas detector head GD-70D series because they have different numbers of terminals (2P for the PLU-70 and 10P for the gas detector head).
- Install wiring for the pyrolyzer unit in the same way as for the gas detector head. For "Specifications of Terminal Plate," "How to Connect to Terminal Plate," "How to Clamp Cables," and "Grounding," see the operating manual of the gas detector head GD-70D series and install wiring accordingly.

### <Figure of Terminal Plate>

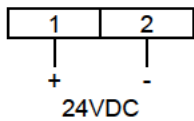

Use the dedicated handling lever.

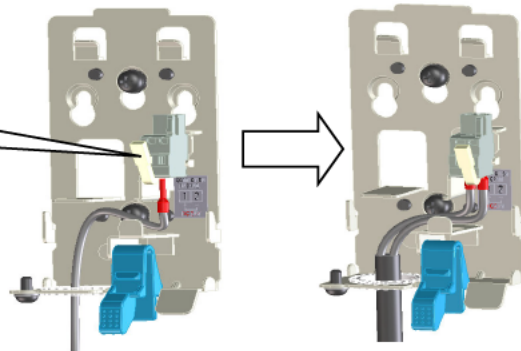

### <Connecting to the Gas Detector Head>

Connect the PLU-70 and the gas detector head using a dedicated communication cable extending from the PLU-70.

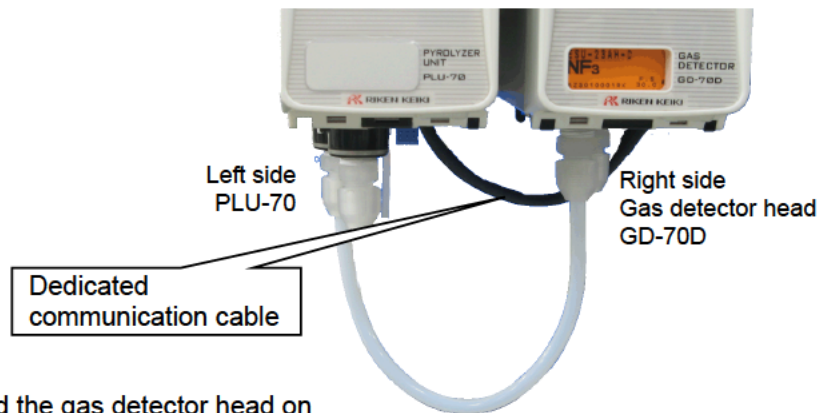

- Install the PLU-70 on the left and the gas detector head on the right when viewed from the front.
- Before making the connection, ensure that the PLU communication connector on the gas detector head is ready for use.
- The dedicated communication connector is a lock type. Check that the connector is firmly locked when you attach it. Unlock the connector before you detach it.

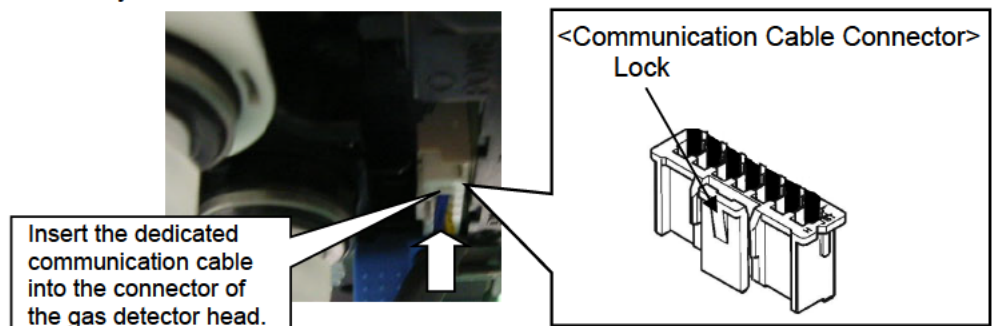





## CAUTION

- Do not hang the communication cable.
- The communication cable connector has a lock feature. Unlock the connector before you detach it. Pulling out a locked connector may result in a trouble such as breaking of the wire.

## NOTE

<Use of the PLU Communication Connector on the Gas Detector Head GD-70D Series>

- Insert a small flathead screwdriver into a gap where the lug of the communication connector cover is protruding, and pull it up in the direction of an arrow in the figure to remove it. Be careful not to damage the connector pins inside by pushing in the flathead driver.
- The communication connector cover is a one-piece component of covers for a dedicated communication cable for the PLU and a LAN cable. Since the cover can be easily split, use it in a way that suits your needs. Keep the cover attached to the connector while it is not connected.
- When you attach the cover, first fit the lug to the gas detector head base unit and then push in the cover.

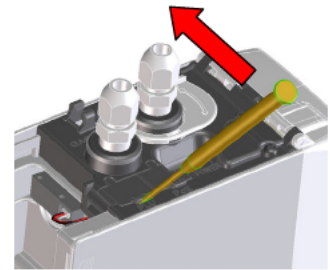

## 2-4. How to tube



- Install tubes between the pyrolyzer unit and the gas detector head GD-70D series, putting the pyrolyzer unit in front of the gas detector head.
- Like the gas detector head, the pyrolyzer unit has a Rc1/4 thread inside of the sampling inlet/outlet (GAS IN, GAS OUT), to which polypropylene unions are normally attached. Connect the tubes basically in the same way as for the gas detector head. (See the operating manual for the GD-70D series.)

### <Connecting to the Gas Detector Head>

To use the gas detector head GD-70D series and the pyrolyzer unit PLU-70 in combination, install tubes to realize a flow in the following direction:

GAS IN -> [PLU-70] -> [Gas detector head GD-70D series] -> GAS OUT

. Please use the dedicated U-tube supplied with the pyrolyzer to connect between the PLU-70 and the gas detector head (between the PLU-70 OUT and the gas detector head IN).

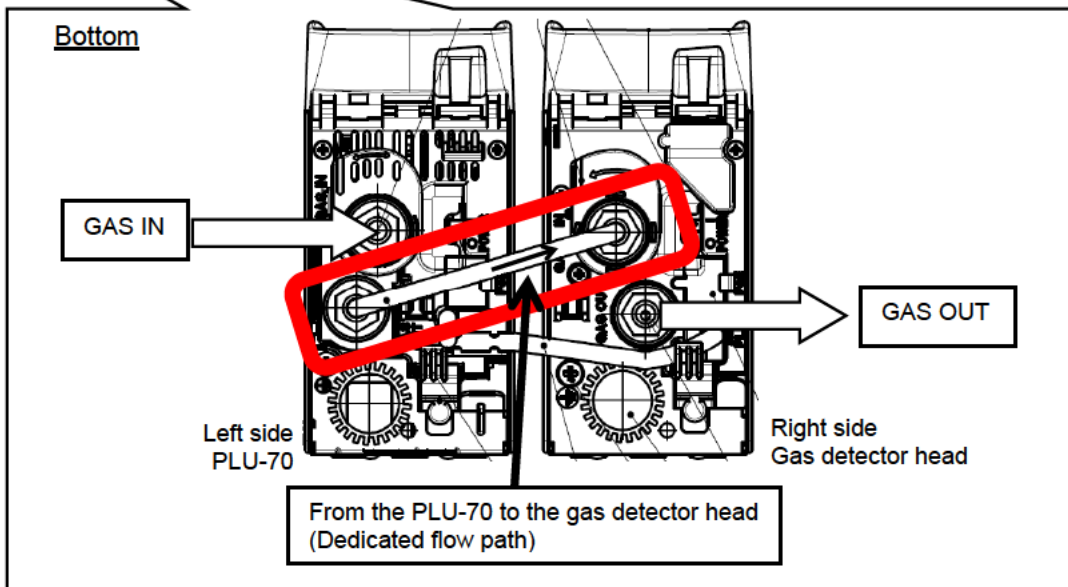
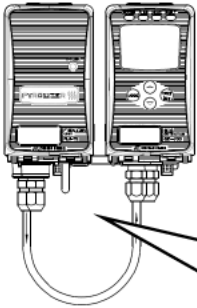

### CAUTION

- Making incorrect tube connections may result in inaccurate gas detection. Double-check the tube connections for errors. No error message is displayed in particular even if the dedicated U-tube is connected incorrectly (i.e., from the gas detector head to the PLU-70).
- Use the dedicated U-tube supplied with the pyrolyzer unit to connect between the PLU-70 and the gas detector head. Using other components invalidates the warranty of the performance.

## 2-5. Relocate

When the pyrolyzer unit is relocated, select a new place in accordance with "Precautions for installation site" and "2-2. Installation of pyrolyzer unit".

For information on wiring and tubing, see "2-3. How to wire" and "2-4. How to tube". The unpowered time must be minimized when the pyrolyzer unit is relocated.



### CAUTION

- When you use a relocated or stopped/stored detector again, do not forget to perform a gas calibration. For information on readjustment including gas calibration, please contact our sales department.

## 2-6. Disposal

When the pyrolyzer unit is disposed of, it must be treated properly as an industrial waste in accordance with the local regulations.

# 3

## How to Operate

### 3-1. Preparation for start-up

Before connecting a power supply, read and understand the following precautions. Ignoring these precautions may cause an electric shock or damage the pyrolyzer unit.

- Check that the pyrolyzer unit and the base unit, gas detector head GD-70D, are connected properly (using dedicated cables and tubes).
- Connect the pyrolyzer unit to a grounding circuit.
- Check that the wiring (power supply wiring) is connected to external power source properly.
- Check that the power supply voltage is compliant with the specifications.
- Check that the dust filter is attached properly.

### 3-2. How to start the pyrolyzer unit

- Before turning on the power switch, check that the pyrolyzer unit is installed properly.
- The power switch is protected by a cover to prevent access to it in a normal time. To turn ON/OFF the power switch, rotate the switch cover. (Return the switch cover to the original position after the switching is completed.)
- Turn ON the power switch.  
The power lamp blinks (and starts to stay lit in an hour).



When the switch cover is closed

When the switch cover is open

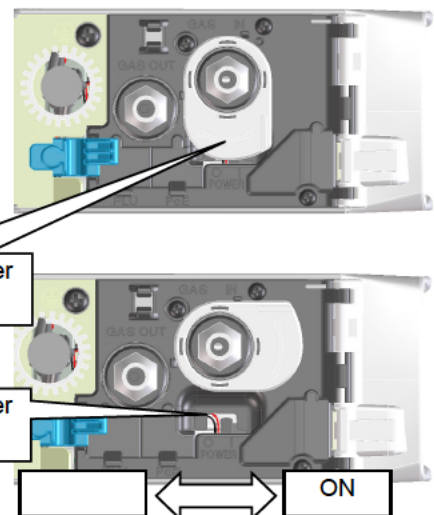

Pyrolyzer unit connection indicator

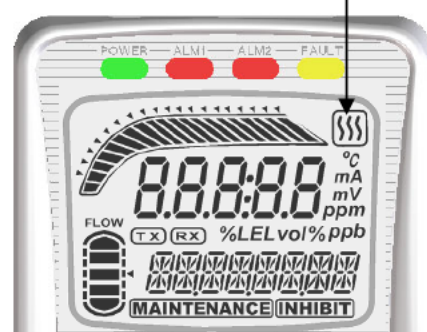

- First turn on the power switch of the pyrolyzer unit PLU-70, and then turn on the power of the base unit, gas detector head GD-70D series. Check that the gas detector head enters the initial clear status and has been started.
- During the start-up procedure, check that the pyrolyzer unit connection indicator appears on the LCD display of the gas detector head.

## <Start-up Procedures (Gas Detector Head)>

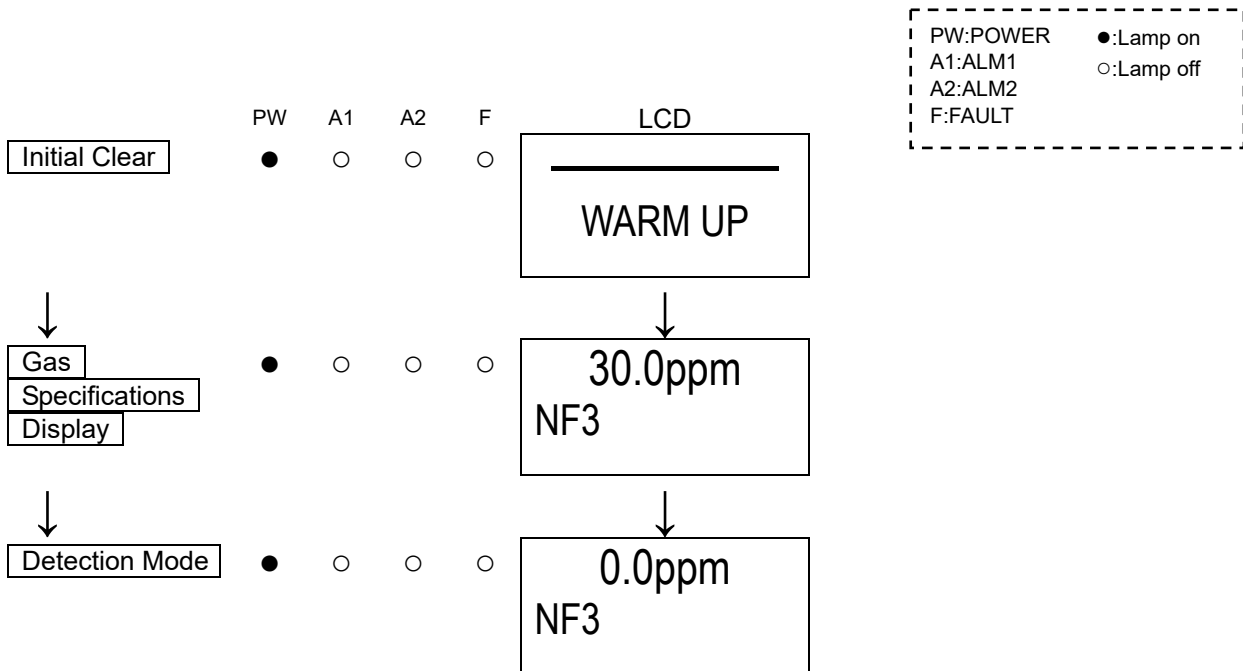

### NOTE

Conduct the operation procedures after start-up using the base unit, gas detector head. For specific operation procedures, see the operating manual of the gas detector head GD-70D series.



### CAUTION

- The pyrolyzer unit must be warmed up until the pyrolyzer reaches a specified temperature and is stabilized.  
Warm up the pyrolyzer unit for about one hour when you use it for the first time or have not used it for a long period (The power lamp on the pyrolyzer unit blinks for one hour after power-on).
- Additionally, the gas detector head (sensor unit) also must be warmed up. Warm up the gas detector head at the same time as the pyrolyzer unit.  
(See the operating manual for the GD-70D series.)

## 3-3. How to exit

To turn off the pyrolyzer unit, open the switch cover on the bottom of the PLU main unit, and turn "OFF" the power switch. Then, turn off the power supply (24 VDC) to the pyrolyzer unit.



- To turn off the pyrolyzer unit, first turn off the power of the base unit, gas detector head GD-70D series, in a reverse procedure to turning on the pyrolyzer unit. (See the operating manual for the GD-70D series.)
- If you turn off the pyrolyzer unit before the gas detector head, a trouble alarm (pyrolyzer abnormalities) is issued.

# 4

## Regular Maintenance Mode

You can check the data (parameters) of the pyrolyzer unit using the menu in the maintenance mode of the gas detector head. The data is displayed on the LCD of the gas detector head.

### <Pyrolyzer Heater Data Display "2-11">

#### Maintenance Mode (Operation on the Gas Detector Head)

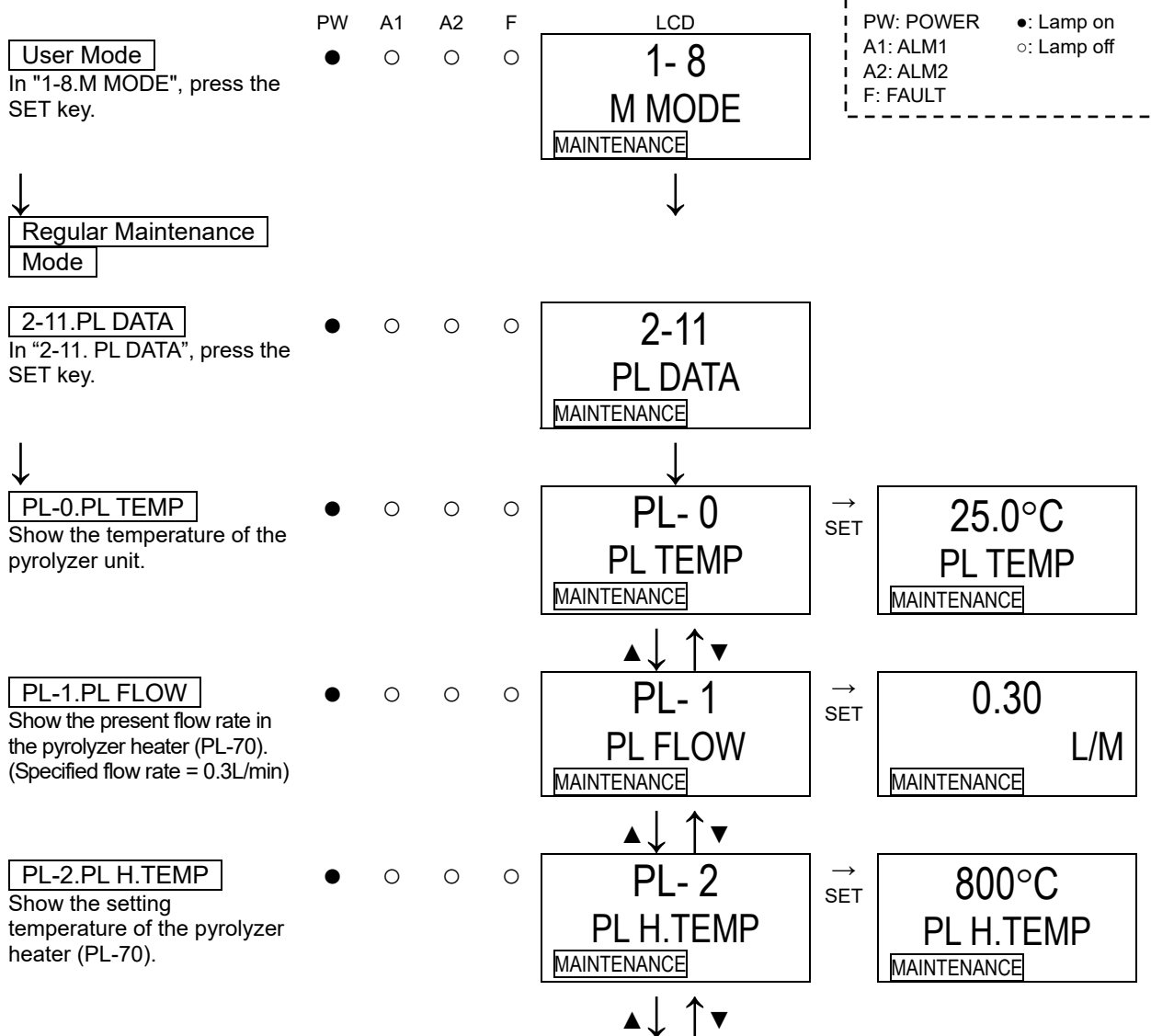

**PL-3.PL POW**

Show the present electric power of the pyrolyzer heater (PL-70).

● ○ ○ ○

▲ ↓ ↑ ▼

PL- 3  
PL POW

MAINTENANCE

→ SET

14725  
PL POW

MAINTENANCE

**PL-4.PL VOLT**

Show the present voltage of the pyrolyzer heater (PL-70).

● ○ ○ ○

▲ ↓ ↑ ▼

PL- 4  
PL VOLT

MAINTENANCE

→ SET

9500mV  
PL VOLT

MAINTENANCE

**PL-5.PL CUR**

Show the present current of the pyrolyzer heater (PL-70).

● ○ ○ ○

▲ ↓ ↑ ▼

PL- 5  
PL CUR

MAINTENANCE

→ SET

1550mA  
PL CUR

MAINTENANCE

**PL-6.PL 3.3V**

This is internal information of the pyrolyzer unit. Used for diagnosis of abnormalities, etc.

● ○ ○ ○

▲ ↓ ↑ ▼

PL- 6  
PL 3.3V

MAINTENANCE

**PL-7.PL 5.0V**

This is internal information of the pyrolyzer unit. Used for diagnosis of abnormalities, etc.

● ○ ○ ○

▲ ↓ ↑ ▼

PL- 7  
PL 5.0V

MAINTENANCE

**PL-8.PL VER**

Show the program version of the pyrolyzer unit.

● ○ ○ ○

▲ ↓ ↑ ▼

PL- 8  
PL VER

MAINTENANCE

→ SET

01234

56AB

MAINTENANCE

**PL-9.PL F AD1**

This is internal information of the pyrolyzer unit. Used for diagnosis of abnormalities, etc.

● ○ ○ ○

▲ ↓ ↑ ▼

PL- 9  
PL F AD1

MAINTENANCE

**PL-10. PL F AD2**

This is internal information of the pyrolyzer unit. Used for diagnosis of abnormalities, etc.

● ○ ○ ○

▲ ↓ ↑ ▼

PL-10  
PL F AD2

MAINTENANCE

To PL-0.PL TEMP

---

## 5

---

# Maintenance

The pyrolyzer unit should be used in combination with the base unit, gas detector head GD-70D series. The pyrolyzer unit is an important instrument for the purpose of safety as the gas detector head. To maintain the performance of the pyrolyzer unit and improve the reliability of safety, perform a regular maintenance on it as well as the gas detector head. For maintenance procedures, see the operating manual of the gas detector head GD-70D series.

### 5-1. Gas calibration method

Perform a gas calibration in the maintenance mode (zero adjustment mode and span adjustment mode) of the gas detector head using the calibration gas.

- Zero adjustment gas (collected in a gas sampling bag)
- Span adjustment gas (collected in a gas sampling bag)
- Gas sampling bags

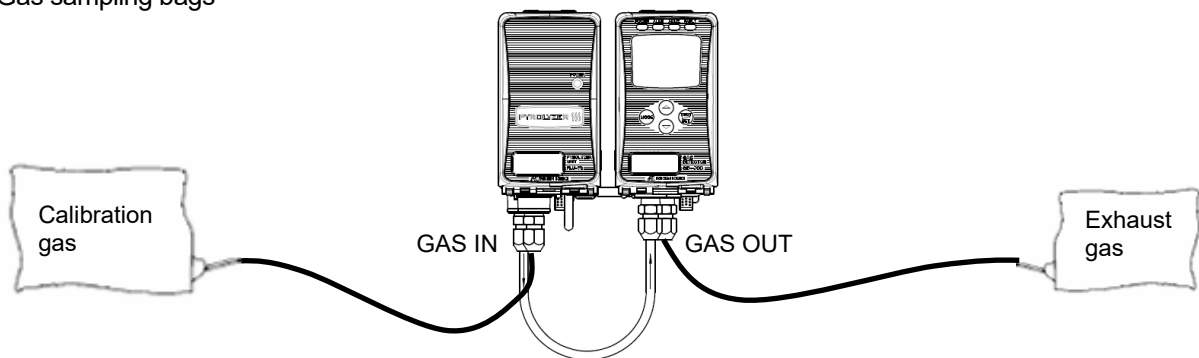

#### NOTE

For specific operation procedures in the zero adjustment mode and the span adjustment mode, see the operating manual of the gas detector head GD-70D series.

---



## 5-2. Other adjustments/Cleaning method

### <Cleaning of Detector>

Clean the pyrolyzer unit if it becomes extremely dirty. The pyrolyzer unit must be turned off while cleaning it. Use a waste cloth to remove dust. Do not use water or organic solvent for cleaning because they may cause malfunctions.

Because an extremely large amount of dust inside the tube may disturb the gas detection, it must be cleaned with dry AIR, etc.

## 5-3. How to replace parts

### <Replacement of Regular Replacement Parts>

List of recommended regular replacement parts

No.	Item	Maintenance intervals	Replacement intervals	Quantity (pieces/unit)
1	Flow sensor	1 year	5 year	2
2	Fan	0.5 years	2 - 4 years	1
3	Pyrolyzer heater	-	2 - 4 years	1

#### NOTE

- The above replacement intervals are recommendation only. The intervals may change depending on the operating conditions. These intervals do not mean the warranty periods either. The result of the regular maintenance may determine when to replace the parts.
- Replace the elbow at the same time as replacing the pyrolyzer heater.

### Replacement of Flow Sensor, Fan, and Pyrolyzer Heater

After the flow sensor, fan, or pyrolyzer heater is replaced, the operation must be checked by a qualified service engineer.

For the stable operation of the pyrolyzer unit and safety, ask a qualified service engineer to take care of replacement of the parts that operation must be checked. Please contact our sales department.

## 5-4. Procedures to store the pyrolyzer unit or leave it for a long time

The pyrolyzer unit must be stored under the following environmental conditions.

- In a dark place under the normal temperature and humidity away from direct sunlight
- In a place where gases, solvents or vapors are not present



#### CAUTION

When you use a relocated or stopped/stored detector again, do not forget to perform a gas calibration. For information on readjustment including gas calibration, please contact our sales department.

## 6

# Troubleshooting

The troubleshooting does not explain the causes of all the malfunctions which occur on the pyrolyzer unit. This simply helps to find the causes of malfunctions which frequently occur. If the pyrolyzer unit shows a symptom which is not explained in this manual, or still has malfunctions even though remedial actions are taken, please contact our sales department.



### **CAUTION**

This section describes troubleshooting on the pyrolyzer unit PLU-70. For information on general troubleshooting on the base unit, gas detector head, see the operating manual of the gas detector head GD-70D series.

### <Pyrolyzer Unit Abnormalities>

Symptom	Causes	Actions
<u>Impossible Power ON</u>	The power switch is turned off.	Turn ON the power switch.
	Abnormalities/momentary blackout of power supply system	Provide the rated voltage. Check the UPS, power supply line filter and insulation transformer, and then take additional measures.
	Improper installation of the PLU main unit	Check that the PLU main unit is properly attached to the wall-mounted unit.
	Cable abnormalities (open circuit/not connected/short circuit)	Check the wiring of detector and related devices around it.
<u>Abnormal Operations</u>	Disturbances by sudden surge noise, etc.	Turn off and restart the pyrolyzer unit. If such a symptom is observed frequently, take appropriate measures to eliminate the noise.
<u>Pyrolyzer Abnormalities</u>  <<On the Gas Detector Head>> - <span style="border: 1px solid black; padding: 2px;">E-7 PL UNIT</span> displayed - FAULT lamp on	PLU-70 power is not turned on.	Turn ON the power switch.
	The dedicated communication cable to the gas detector head is not connected or improperly connected.	Check that the dedicated communication cable is connected and the cable connector is securely fastened.
	Abnormalities inside the pyrolyzer heater such as abnormal overheating of the pyrolyzer heater or stop of the fan (Rapid blinking of the pyrolyzer unit power lamp).	Check that nothing is hanging on the pyrolyzer fan and that no foreign matter has got stuck in the fan. If it gets hot inside a closed panel, install a fan on the panel itself or take other necessary measure for heat dissipation. In the case of a pyrolyzer heater or fan failure, please contact our sales department because parts replacement is required.
	The dedicated communication cable has been connected by mistake to a gas detector head that does not need the PLU-70 as per its specifications.	Reconnect the cable to a gas detector head that needs the PLU as per its specifications (such as NF3).

<b>Symptom</b>	<b>Causes</b>	<b>Actions</b>
	A sensor unit that does not need the PLU-70 as per its specifications has been installed by mistake.	Replace the sensor unit installed on the gas detector head with a sensor unit that needs the PLU (such as NF3).



## EU-Declaration of Conformity

Document No.: 320CE21027



We, RIKEN KEIKI Co., Ltd. 2-7-6, Azusawa, Itabashi-ku, Tokyo, 174-8744 Japan declare under our sole responsibility that the following product conforms to all the relevant provisions.

Product Name: Pyrolyzer Unit (for GD-70D Series)  
Model: PLU-70

Council Directives		Applicable Standards
2014/30/EU	EMC Directive	EN 61326-1:2013
2011/65/EU	RoHS Directive	EN IEC 63000:2018

Place: Tokyo, Japan

Date: Sep. 22, 2021

Takakura Toshiyuki  
General manager  
Quality Control Center