

OPERATING INSTRUCTION MANUAL

FOR

INDICATOR/ALARM UNIT OX-592

FOR USERS

RIKEN KEIKI Co., Ltd.

2-7-6 Azusawa, Itabashi-ku, Tokyo, 174-8744, Japan

Phone : +81-3-3966-1113

Fax : +81-3-3558-9110

E-mail : intdept@rikenkeiki.co.jp

Web site : <https://www.rikenkeiki.co.jp/>

CONTENTS

1. PRODUCT OUTLINE

1-1 In the beginning	3
1-2 Application for use	3
1-3 Identification of each caution marks	3
1-4 Method of confirmation for CE marking type	4

2. IMPORTANT INSTRUCTION FOR THE SAFETY

2-1 Danger items	5
2-2 System composition	5
2-3 Caution items	6

3. PRODUCT FUNCTION

3-1 External drawing(with single case)	7
3-2 Appearance(with single case)	7
3-3 Panel cut-out dimensions	8
3-4 Name of each part and function	9
3-5 Block diagram	10

4. HOW TO USE

4-1 Before operation	11
4-2 Mounting/dismounting procedures	11
4-3 Installation place	12
4-4 Caution in the system engineering	13
4-5 Grounding	15
4-6 Wiring	16

5. OPERATION METHOD

5-1 Preparation for Start up	17
5-2 Basic performance flow	17
5-3 Start-up method	18
5-3-1 Power on	18
5-4 Explanation of performance (Detection mode)	19
5-4-1 Display action	19
5-4-2 External output action	20
5-5 Maintenance and adjustment	21
5-5-1 Maintenance mode	21
5-5-2 Adjustments	22
5-5-2-1 Span adjustment(For prevention of oxygen deficiency)	22
5-5-2-2 Zero adjustment(For general detection)	23
5-5-3 Confirmation of alarm level	24
5-5-4 Change of alarm level	24
5-5-5 Confirmation of peak hold level	25
5-5-6 Alarm test	26
5-6 How to finish operation	26

6. KIND OF ALARM AND ITS FUNCTION	
6-1 Kind of alarm	27
6-2 Gas alarm	27
6-2-1 Gas alarm action	27
6-2-2 Counteraction at gas alarm	28
6-2-3 Gas alarm possibility except the case of gas detection	28
7. MAINTENANCE AND CHECK	
7-1 Frequency of maintenance and check items	29
7-1-1 Daily check	29
7-1-2 Regular maintenance check	29
7-2 Maintenance contract for regular check	29
7-3 Replacement of sensor parts	30
7-4 Treatment when operation is stopped or its installation place is moved	30
7-4-1 Stop at normal operation	30
7-4-2 Installation when move its place	30
7-5 Storage and treatment when not use for a long time	30
8. SCRAP OF PRODUCT AND SENSOR	30
9. MEASURES AT ABNORMAL CASE	
9-1 Trouble alarm	31
9-2 Counteraction at trouble alarm	31
9-3 Before it is thought to be trouble	31
9-4 Trouble shooting	31
10. DEFINITION OF TERMS	33
11. PRODUCT SPECIFICATIONS	
11-1 Specifications	34
11-2 Product composition	34

1. PRODUCT OUTLINE

1 — 1. In the beginning

First of all, we wish to express our heartfelt thanks for your purchase of our indicator/alarm unit OX-592. This instruction manual is just a guide book to operate indicator/alarm unit OX-592 of RM-590 series. Your kind reading of this manual is requested not only for first user but for already experienced staff.

1 — 2. Application for use

- This is an exclusive indicator/alarm unit to be used in combination with our oxygen detector head to indicate oxygen concentration for the control of oxygen deficiency prevention, etc.
- Oxygen is detected with a galvanic cell type oxygen detector head which is connected with this indicator/alarm unit. Detection results are displayed with 4-digit LED indicator.

Application \ Spec.	Detection range	Action	1st alarm	2nd Alarm
Prevention of oxygen deficiency	0 ~ 25vol%	Lo-LoLo alarm	Lo	Lo
General detection (Including oxygen leakage)	0 ~ 5vol%	Hi-HiHi alarm	Hi	Hi
	0 ~ 10vol%	Lo-Hi alarm	Lo	Hi
	0 ~ 50vol%	Lo-LoLo alarm	Lo	Lo

Take care that an alarm action and a relay output are different from application for use. This operating instruction manual describes on the application for prevention of oxygen deficiency.

1 — 3. Identification of each caution marks



Indicates an imminently hazardous situation which, if not avoided, will result in death or serious injury. This signal word is to be limited to the most extreme situation.



Indicates a potentially hazardous situation which, if not avoided, could result in death or serious injury.



Indicates a potentially hazardous situation which, if not avoided, may result in minor or moderate injury. It may also be used to alert against unsafe practices.

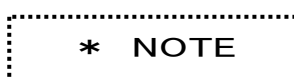

This means "ADVICE" at operation.

1 — 4. Method of confirmation for CE marking type

The CE marking is labeled on the detector in case of comply with CE marking. Please confirm the instrument specification before using. Please refer Declaration of Conformity that is at the end of this manual if you have CE marking type.

You can confirm instrument specification to see the CE marking as follows.

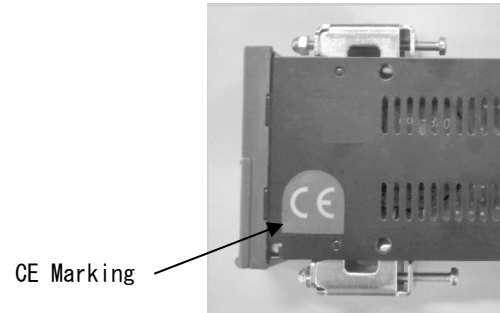

CE marking label (Right side of instrument)

2. IMPORTANT INSTRUCTION FOR THE SAFETY

2-1. Danger items

DANGER

This is not an explosion proof unit. Do not use it in a hazardous area. It is dangerous to use this unit in such an environment.

2-2. Warning items

WARNING

- **Detector head**
Do not connect another detector head than the designated oxygen detector head.
If connected, you cannot detect gas. Furthermore, this unit or other connected unit may be broken.
- **Power source**
Before supplying the power, confirm that the power source is a designated voltage.
- **Necessity of protective grounding**
Do not cut inside or outside wire for earth, nor disconnect the wire from the earth terminal.
In any case, the unit becomes in dangerous conditions.
- **Defect of protective function**
Do not operate the unit if protective functions such as protective grounding or fuse seem to be defective.
Also, before operating the unit, confirm that there is no defect for protective functions.
- **Fuse**
Use the designated rating (current, voltage, type) fuse to prevent fire.
Replacement of fuse shall be done after putting off the initial power source and putting off the power switch of this unit.
Do not use another fuse than the designated one, nor make a short circuit for the fuse holder.
- **External connections**
After making protective grounding firmly, connect to the external control circuit or detection objective.
- **Counteraction at gas alarm (Prevention of oxygen deficiency)**
When detecting low concentration gas than the preset alarm level, it is very dangerous.
It is required to take appropriate measures by the customer's decision.
- **Mounting/dismounting**
Locking mechanism may be broken if the unit is mounted into the case with the disengagement lever up position. Make correct procedure for mounting/dismounting.

2—3. Caution items

 CAUTION

- Do not use walky-talky, mobile phone, etc. near this unit.
When this unit receives the electric waves by walky-talky etc near from the cable, this will effect the reading. When use the walky-talky, operate it at the place where there is no influence of electric wave emission.
- When make power on again, make it after an interval of over 5 seconds.
When make power on within 5 seconds, there may be no normal operation.
- When operate it not to follow this manual, repair it by other rating parts or modify it on his own, the safety and quality of products cannot be secured. Then, when an accident take place by it, we cannot assure our responsibility on them.
Take enough consideration for instrumentation to keep safety even if disconnection of power and signal lines, defect of operation or trouble would be happen due to unexpected reason.
This is an electrical applied instrument.
Be care it may be effected by power noise, electrostatic and electromagnetic noise.
When use under such conditions, make protective treatment for use.

3. PRODUCT FUNCTION

3-1. External drawing (with single case)

*Refer to the operating instruction manual for multi-unit case when multi-unit case is used.

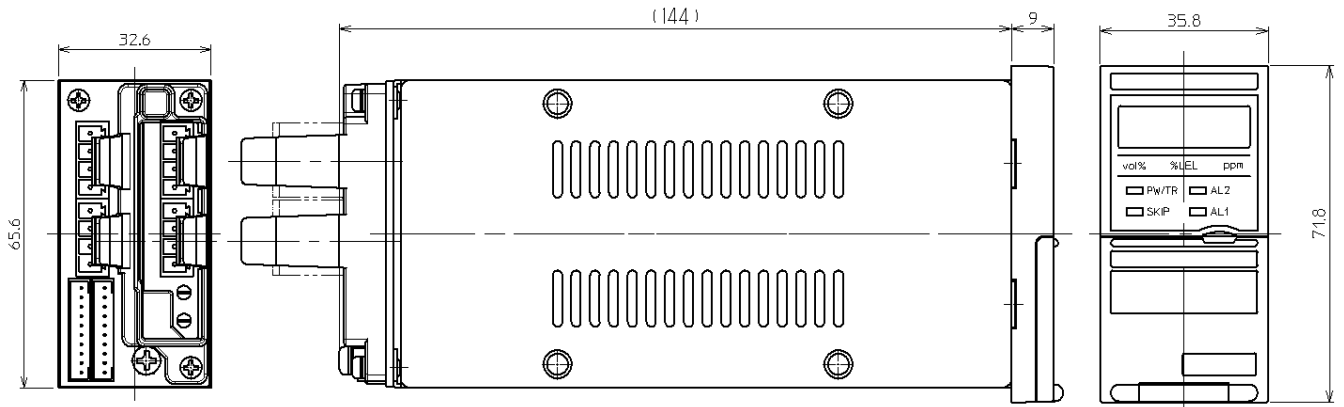

3-2. Appearance (with single case)

*Refer to the operating instruction manual for multi-unit case when multi-unit case is used.

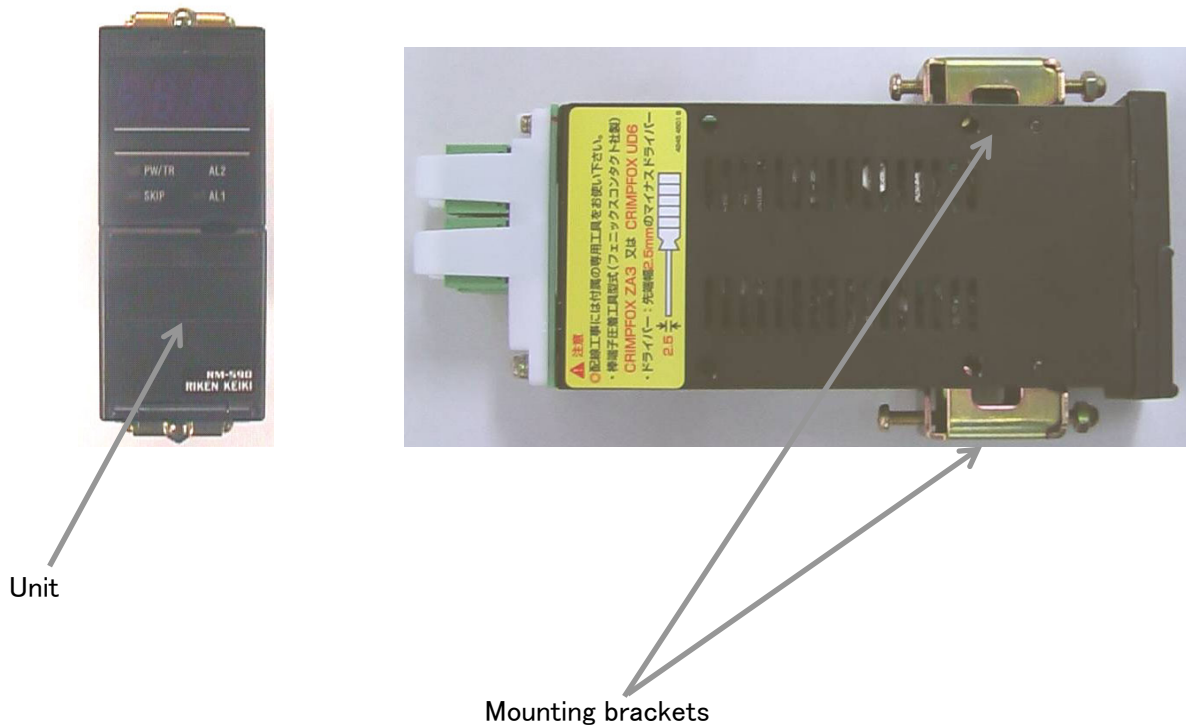

3-3. Panel cut-out dimensions

Refer to the instruction manual for multi-unit case if installed the unit to multi-unit case.

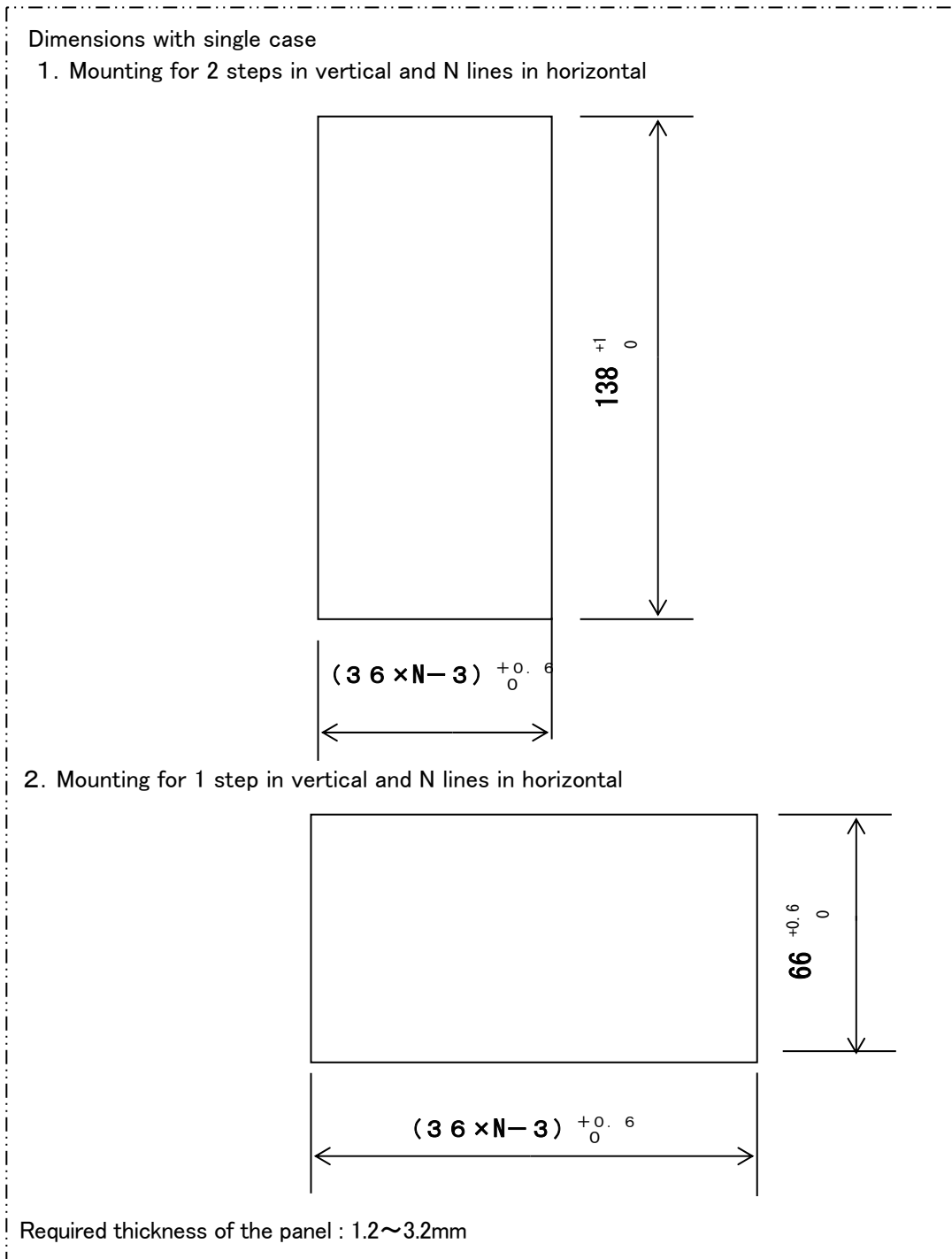

CAUTION

Please consult us or with our agent for installation method or installation quantity to avoid trouble caused by radiating heat.

3 — 4. Name of each part and function

*The below pictures show indicator/alarm unit with single case.

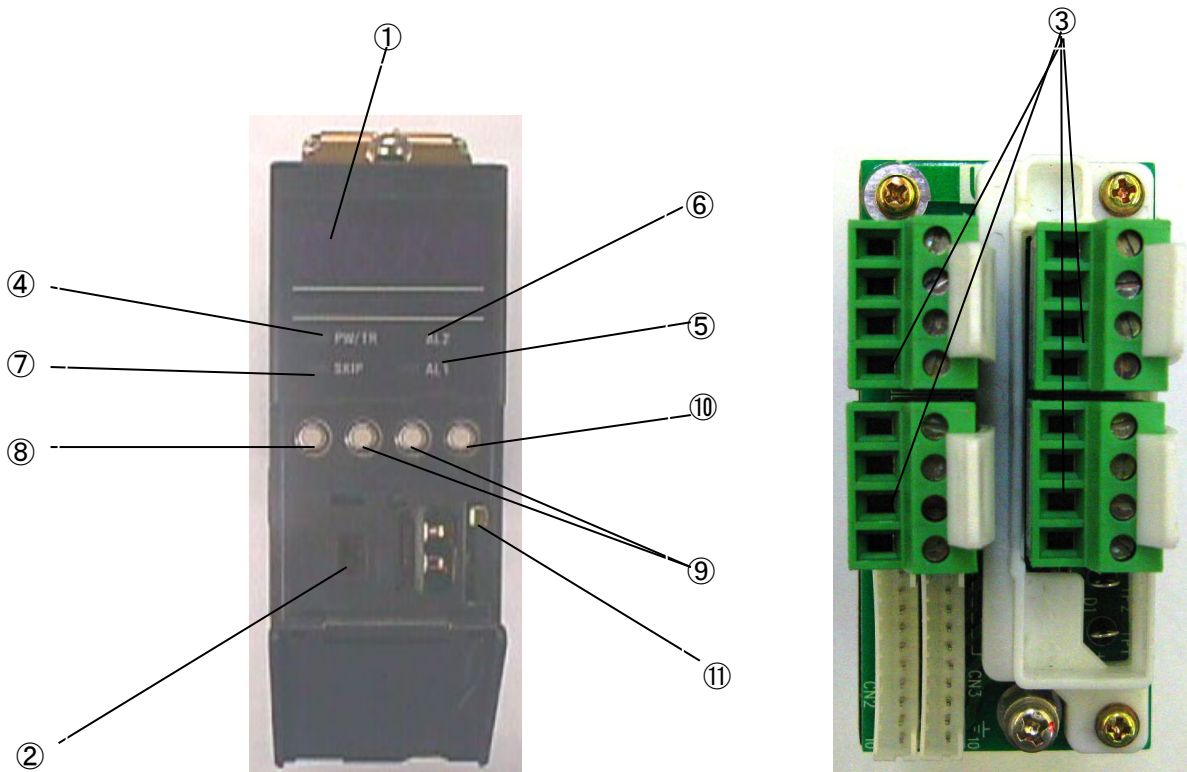

- ① LED display..... Indicates gas concentration.
- ② POWER switch..... ON/OFF switch
- ③ Terminal plates..... Connects cables from outside.
For multi-unit case refer to instruction manual for multi-unit case.
- ④ PW/TR light..... Combination light for power and trouble indication.
Steady light : Power ON, normal operation
Flashing : Trouble
- ⑤ AL1 light..... Flashes at gas alarm (1st alarm)
- ⑥ AL2 light..... Flashes at gas alarm (2nd alarm)
- ⑦ SKIP light..... Flashes during maintenance mode.
- ⑧ MODE switch..... Uses at maintenance work.
- ⑨ UP/DOWN switch..... Uses to select items at maintenance mode, increase or decrease reading at zero and span adjustments, and to increase or decrease reading at alarm test.
- ⑩ SET switch..... Uses to change for alarm test mode.
- ⑪ Disengagement lever..... Locks the indicator/alarm unit.

3 — 5. Block diagram

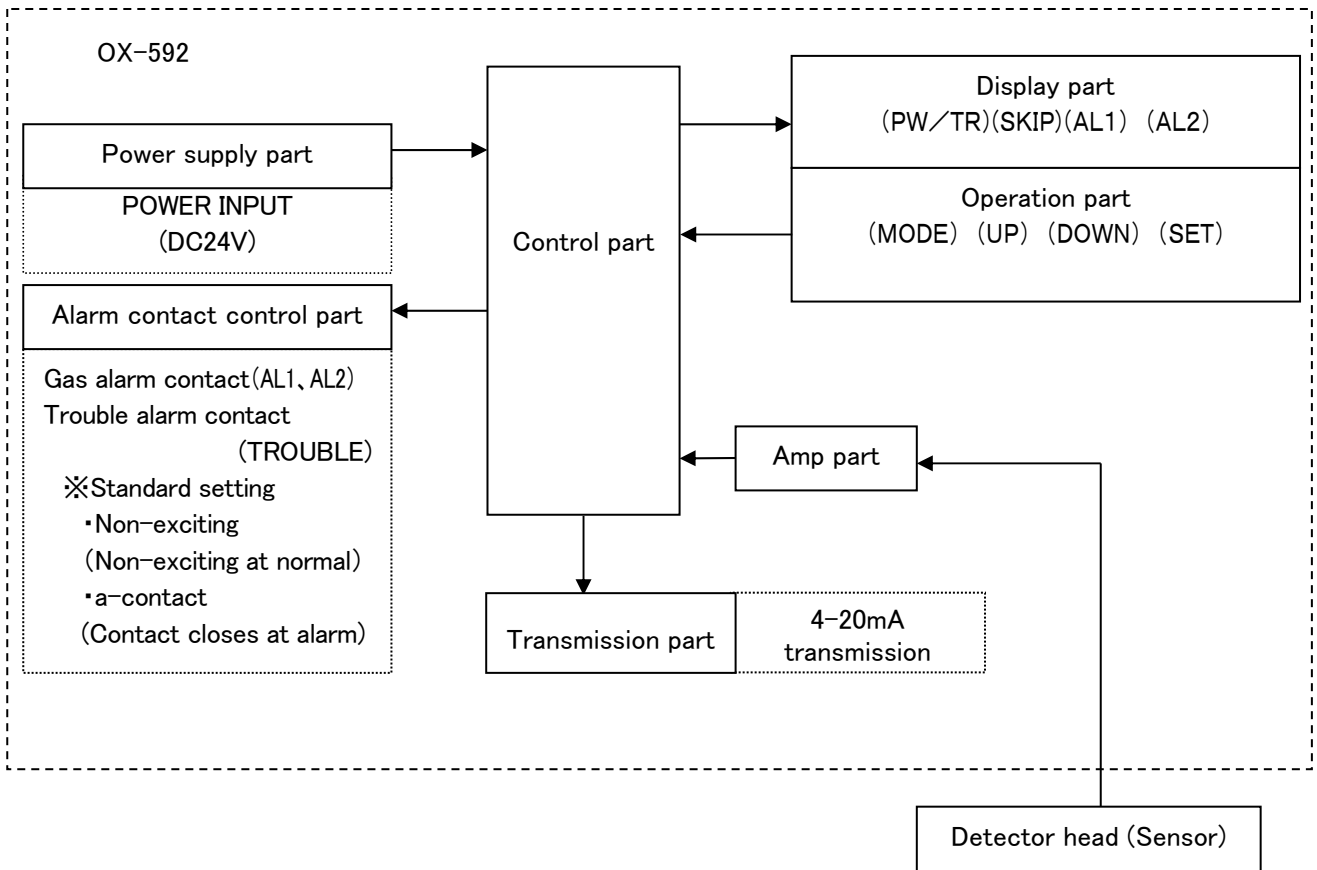

4. HOW TO USE

4 — 1. Before operation

Be sure to keep caution items of use not only for first user but for already experienced staff.
If not keep these caution items, the unit may be defective and correct gas detection may not be performed.

4 — 2. Mounting/dismounting procedures

Indicator/alarm unit for RM-590 series shall be used after housing it in either exclusive single case or multi-unit case.

(1) Mounting method

- Open the front cover of this unit.
- Confirm that the power switch is at OFF.
- With the disengagement lever at down position, mount into the case.
(Confirm that the edge connector is put in firmly)
- Confirm that the disengagement lever is turned upward when indicator/alarm unit is mounted into the case firmly.
- After confirmation of lever position, put ON the power switch, and then, close the cover.

(2) Removal of the unit

- Open the front cover of this unit.
- Confirm that the power switch is at OFF.
- Push disengagement lever down to release the lock.
- Pull out the unit from the case.
- Turn the lever upward and close the cover.

CAUTION

Mounting/dismounting of indicator/alarm unit shall be done according to the above procedures. If not, stopping metal of the unit may be transformed and the cover can not be closed.

4 — 3. Installation place

CAUTION

Do not install at places where direct sun drought or where the temperature is drastically changed.

Keep away the system from direct sun drought or where the temperature of the system is drastically changed. If installed, inside the unit will be built up condensation and does not follow the drastic temperature change.

Do not install it where vibration or shocks may take place.

The system consists of fine electronics parts.
Install them where to be stable not to crush or fall down.

Keep the system from the equipment which may generate the noise (Unit & cable).

Keep the system from the equipment which may give a high frequency in the surroundings and install it.

- Do not put the system jointly each.
- Do not wire the cable in parallel nor take access.

Do not install it where the detection gas is deposited around.

Do not install and make gas detection at the place where the sample gas is deposited.

Do not install at the place where it is danger for maintenance service such as high voltage cable, etc.

This unit is required to make maintenance regularly.
Then, do not install at the place where there is danger at maintenance time.

Do not install it where it is unable to make maintenance.

When required to stop the system at maintenance time, unable to maintain if not remove a part of system or unable to detach the case due to the pipe or rack etc. do not install such place.

Equipment housing that grounding construction is not enough.

Be sure to ground when installing to the equipment.

4 — 4. Caution in the system engineering

CAUTION

Unstable power and noise may cause error of performance and alarm.
 For the system to use this unit, it is required to make design based on this manual descriptions.

(1) Stable power used

While the system gets stable at power failure, the external output and alarm contact may be on and the care for it must be taken. In such case, use the standby battery or take an appropriate action in the receiver side. Supply the following power to this unit.

Power voltage	DC24V±10%
Power failure tolerance time	Approx 50msec. (For power failure of 50msec, it re-starts) To warrant the continuous operation, install the UPS (Uninterrupted Power Supply) or standby battery outside.
Others	Do not share the power involving with high power load and high frequency noise. According to requirement, use line filter and separate it from noise source.

(2) Designing to consider radiation

When install the closed self-standing control panel, mount the fans in the upper and lower part.

(3) Lightning measures

Lightning surge	There is the problem “Lightning”. When make outdoor wiring of cable at factory or plants etc or when make a parallel wiring in the same duct with the cable in from outdoor even at the indoor wiring. If the lightning is a huge generation source, the cable is a reception antenna and there is the case that cable connecting instrument is broken. It is impossible to prevent the generation of lightning. If the cable should put in metal tube or laid in the underground, it is impossible to prevent the inductive lightning surge generating from the thunder.
Lightning measures	There is not the complete countermeasure for it but the following method can be considered. Make the suitable treatment accordingly. a) The transmission signal route is arranged for connection by the optical fiber cable etc. b) Countermeasure by the lightning arrester (Cable safety retainer). There is the way to install the lightning arrester just before the field apparatus and the central control station. The position of the lightning arrester installation is at each point of cable laid out from the outdoor to the indoor. The lightning arrester builds in the circuit to remove the surge voltage to be the source for the damage of field apparatus (Protection resistor, zero diode etc.) and is designed to protect the apparatus. But as the signal may be attenuated due to the lightning arrester, check the action and it is required to use.
Grounding	Surge noise shall be generated from the thunder lightning or except it. To protect detector from these cause, be sure to make grounding.

*In the lightning rod, there is the circuit to remove the surge voltage to be a cause of damage from field instruments.

By installing the lightning rod, the signal may be attenuated. When install the lightning rod, it is required to check the performance in advance.

(4) Alarm contact

- Alarm contacts shall be used only for external buzzer and alarm light, and do not use it for the controlling use (such as solenoid valve control etc).

When control the external load, the bad influence may be given to the system according to the load characteristics. In such case, the following countermeasure shall be taken to stabilize the action and protect the contents.

- Relayed by the low voltage relay and operate by connecting CR circuit (Spark Killer: SK) (Diode etc for DC) suited for relay coil directly to relay.
- Add CR circuit to the load side of relay on the request.

⚠ CAUTION (FOR USE OF NORMALLY-CLOSED CONTACT)

Normally-closed contact (Break contact) at non-existing condition may change to open contact in a moment due to physical shock.

Whenever alarm signals from gas detectors are used with normally-closed contact, please put delayed-circuit (for about one second) to receiver side of normally-closed contact to avoid such phenomenon.

Reference : By the condition of load, CR circuit may be better to install in the contact side but it is required to put in by checking the action of load.

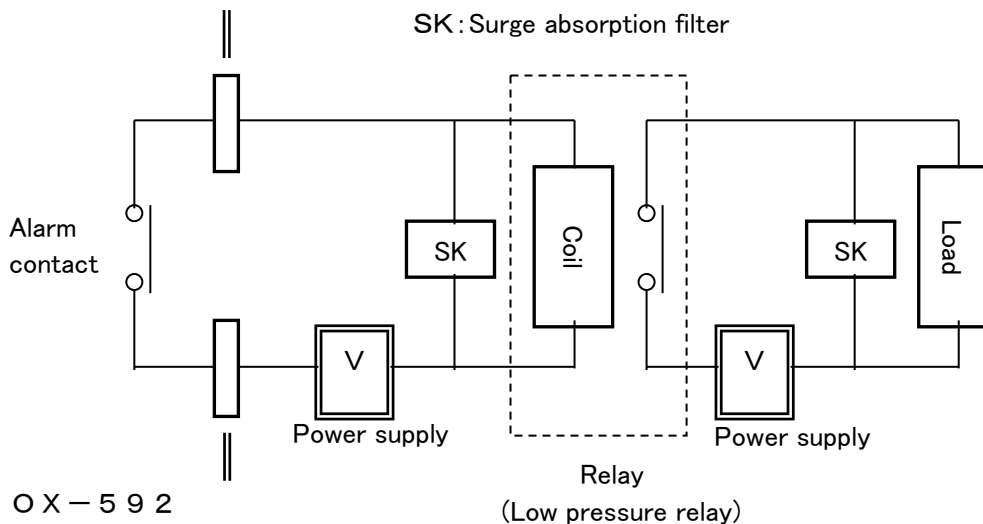

—How to think alarm contacts against inductive load—

The spec for alarm contact of OX-592 is described by the conditions of resistive load.

When use the inductive load for alarm contacts, the very high reverse electromotive voltage may be generated and the following trouble tends to be produced.

- Contact part of relay is melted adhesively and the contacts can no work.
 - High voltage is put inside of indicator/alarm unit and then, electrical parts may be damaged.
 - As it is big noise, the trouble action may be taken by the reckless drive of CPU.
 - Irrespective of inductive load, there is the possibility of unforeseeable noise instruction for contact.
- Above trouble may be generated.

⚠ CAUTION

- The inductive load shall not be used in principle (Do not use fluorescent lamp).
- When use the inductive load, make the contact amplification outside, but the outside relay coil belong, use the relay driven by the low voltage (within AC100V) and it is protected by an appropriate surge killer.

※ As the inductive load, there are following samples.

- Revolving light * External relay * Buzzer *Siren *Fan *Fluorescent lamp * Motor etc.

4—5. Grounding

Make grounding with terminal \perp .

⚠ WARNING

Be sure to make grounding before putting power ON.

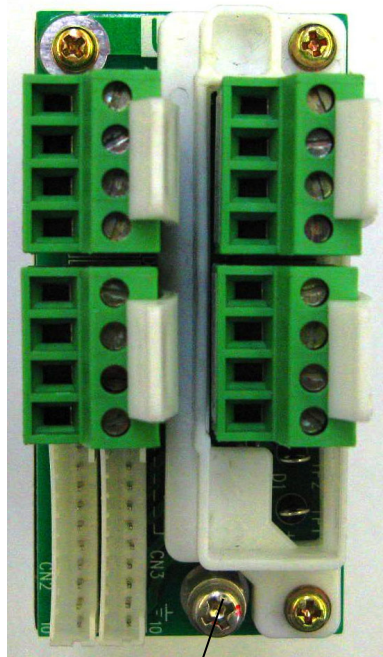

Terminal \perp

Be sure to make grounding for safety purpose and to keep stable operation of this unit.
Do not connect earth wire with gas pipe. Make grounding corresponding to D-class grounding (Grounding resistance : below 100ohms).

4 — 6. Wiring

(In case of single case)

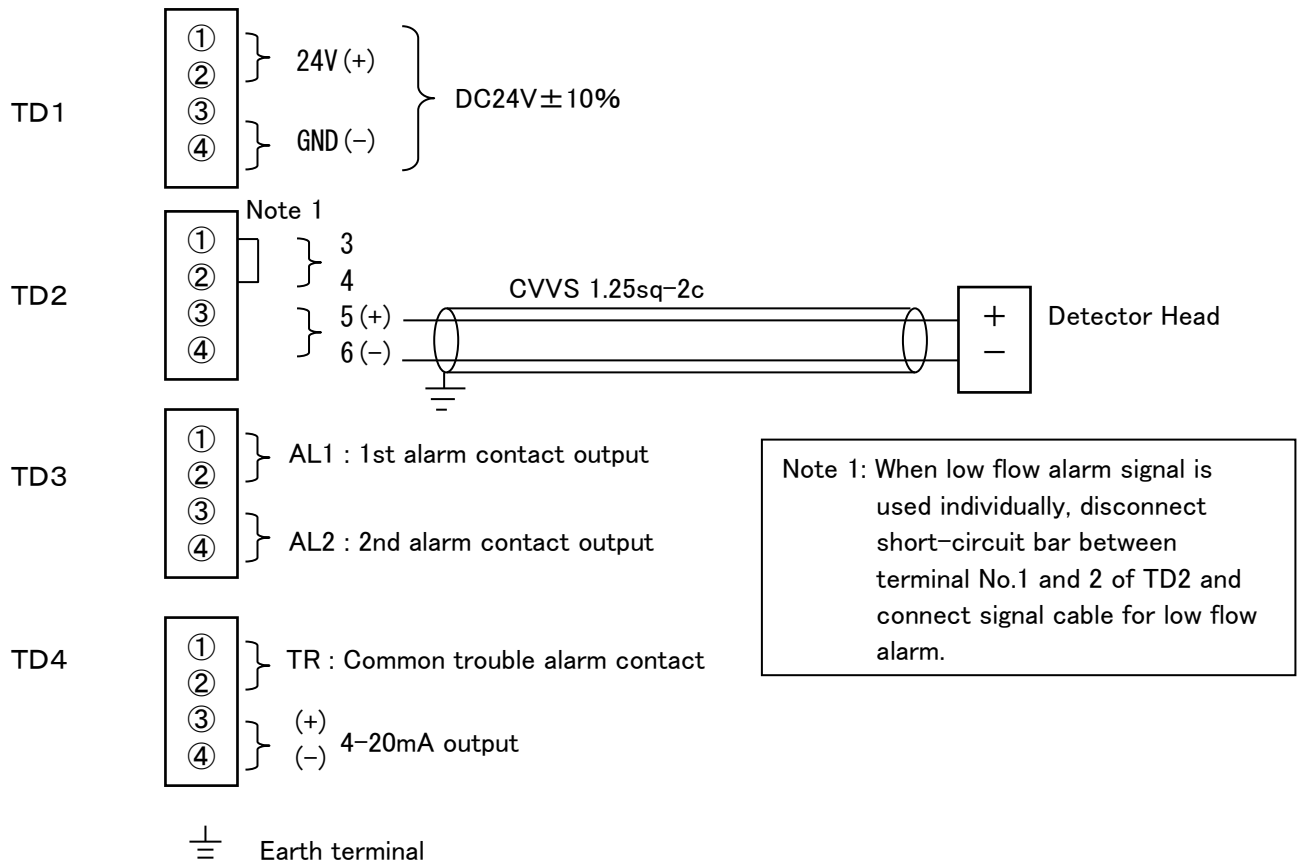

Maximum cable length: 1.25km

For multi-unit case, refer to operating instruction for multi-unit case.

⚠ CAUTION

- Use CVVS 1.25sq cable for the connection of detector head.
- Do not distribute power cable and signal cable together with power line for motor, etc.
- This unit applies a connector type terminal plate for easy wiring. Be care not to give a high load to the connector.
- We can not warrant the performance of this unit if undesignated cable is used.

5. OPERATION METHOD

5-1. Preparation for start-up

● Before putting power ON.....

Before putting power ON, keep following caution items. If not, danger for electric shock or damage to the unit will be happen.

- (1) Make grounding.
- (2) Check that wirings with outer units are made correctly.
- (3) Check that the supply voltage is within a rating.
- (4) Relay contact for outer alarm may work during adjustments. Even relay contact works, treat that any influence will not be given to the outer.
- (5) To prevent fire, check that the designated fuse is used.

5-2. Basic performance flow

In normal operation, it is used on detection mode.

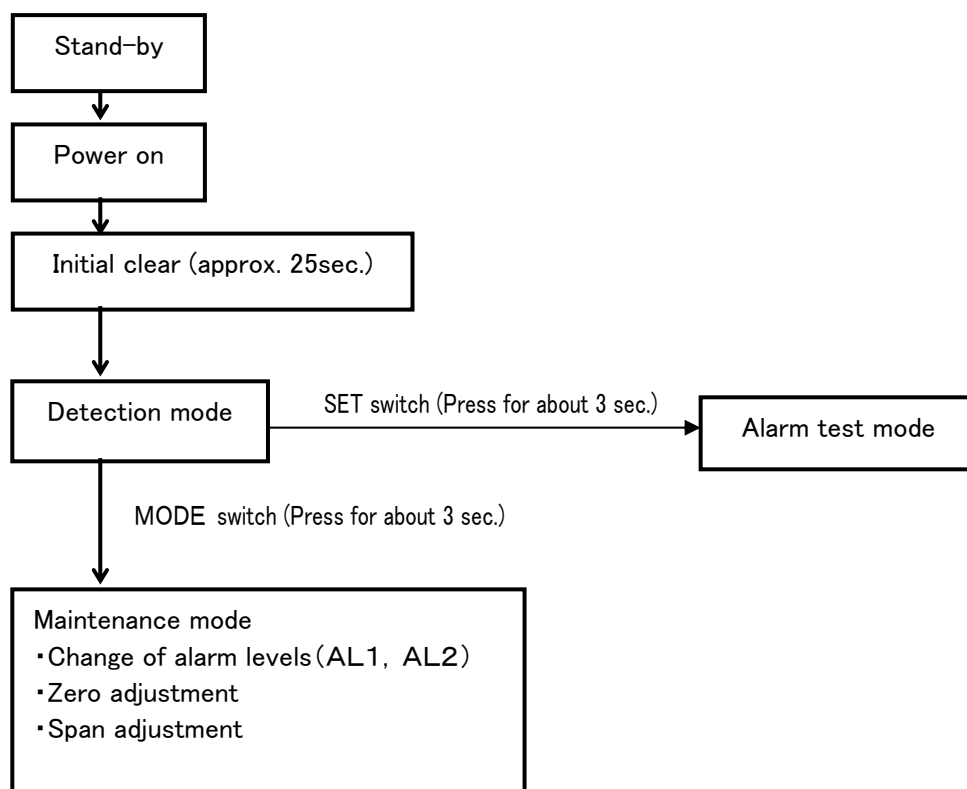

CAUTION

Maintenance mode shall be performed by the specialized service man. Do not operate it without permission.

5—3. Start-up method

5—3—1. Power on

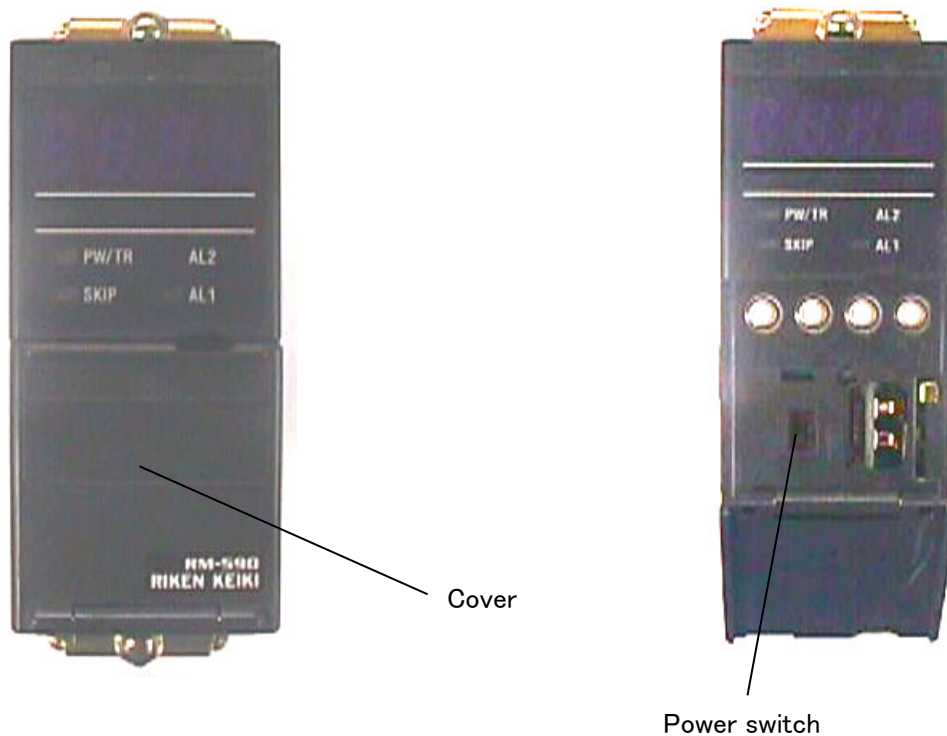

- 1) Before making power on, check that the unit is connected correctly.
- 2) The power switch can be seen when the front cover is opened.
- 3) Put the power switch upward to ON and downward to OFF.
- 4) Put the power switch on, and power light illuminates.
- 5) Status of initial clear (about 25 sec.) is displayed as “- - - -”.
 - Checking of the system (Self-diagnosis)
 - Output signal : Approx 17.4mA(In case of 0-25% range for oxygen deficiency detection)
 - Gas alarm, trouble alarm (light, contact) shut-off.

5-4. Explanation of performance (Detection mode)

5-4-1. Display action

There are following two kinds of displays.

- (1) LED display : Shows gas concentrations.
- (2) LED light : Shows power/trouble (PW/TR), 1st gas alarm(AL1), 2nd gas alarm(AL2) and maintenance (SKIP) condition.

※ Contents of indications by LED display and LED light are different from the condition of the unit.

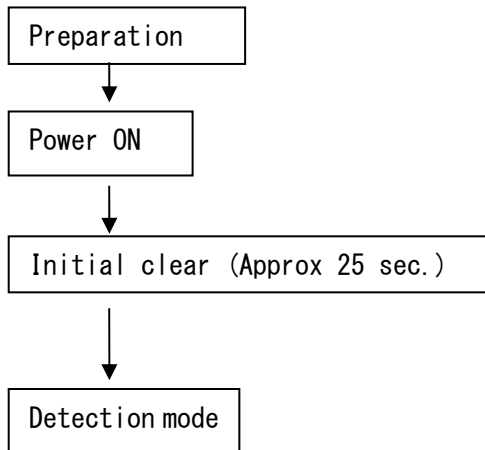

Only PW/TR light illuminates at detection mode and LED display show detected gas concentration.

Action of LED light

□:Light off ■:Light on ⊙:Flashing

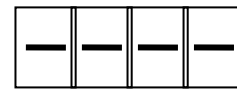

PW/TR	AL2
■	□
SKIP	AL1
□	□



PW/TR	AL2
■	□
SKIP	AL1
□	□

Gas alarm condition

When gas concentration reaches 1st alarm level and 2nd alarm level, alarm lights AL1 and AL2 flash respectively. Also, LED display shows gas concentration.



PW/TR	AL2
■	⊙
SKIP	AL1
□	⊙

Trouble condition

When any of trouble arise on gas detection, PW/TR light flashes and content of trouble is shown on LED display.

(LED display) (Content of trouble)

- E-00 System trouble
- E-01 Sensor/detector head disconnection or not yet connected.



PW/TR	AL2
⊙	□
SKIP	AL1
□	□

5-4-2. External output action

- (1) Signal transmission method : Electric current transmission (Non isolation)
- (2) Transmission path : CVVS
- (3) Transmission distance : Below 1 Km
- (4) Resistive load for connection : Below 300 Ω
- (5) Status signal level

«0~25vol% for prevention of oxygen deficiency»

- ①Detection mode : 4-20mA(Depends on gas concentration)
- ②Gas alarm : 4-20mA(Depends on gas concentration)
- ③Initial clear : 17.4mA(Fixed)
- ④Maintenance mode : 17.4mA(Fixed)
- ⑤Alarm test : 4-20mA(Depends on gas concentration)
- ⑥Trouble alarm : 0.5mA(Fixed)
- ⑦Point skip : 17.4mA(Fixed)

«For general detection»

- ①Detection mode : 4-20mA(Depends on gas concentration)
- ②Gas alarm : 4-20mA(Depends on gas concentration)
- ③Initial clear : 2.5mA(Fixed)
- ④Maintenance mode : 2.5mA(Fixed)
- ⑤Alarm test : 4-20mA(Depends on gas concentration)
- ⑥Trouble alarm : 0.5mA(Fixed)
- ⑦Point skip : 2.5mA(Fixed)

- (6) Power shut off : 0mA

Relation between 【Gas concentration】 and 【Output】 are shown below.

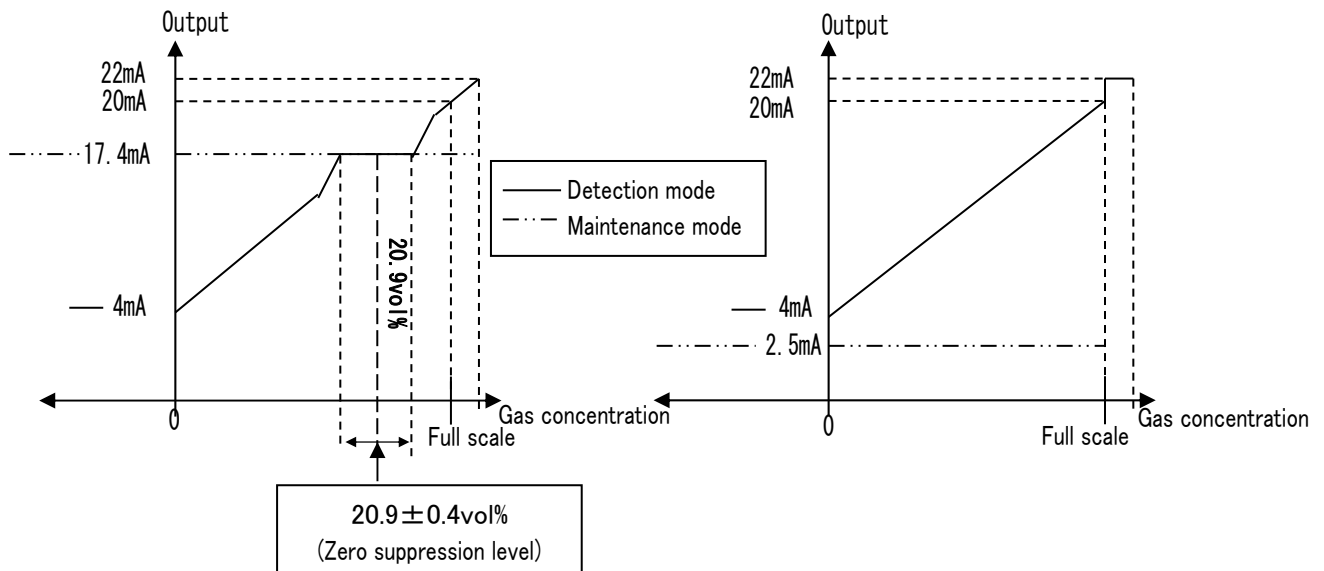

«0~25vol% for prevention of oxygen deficiency»

«For general detection»

CAUTION

4-20mA outputs are already adjusted. If re-adjustment is required after installation, specialized service man will make re-adjustment.
Do not make this adjustment without permission.

5—5. Maintenance and adjustment

5—5—1. Maintenance mode

When make each adjustment, make it on maintenance mode.

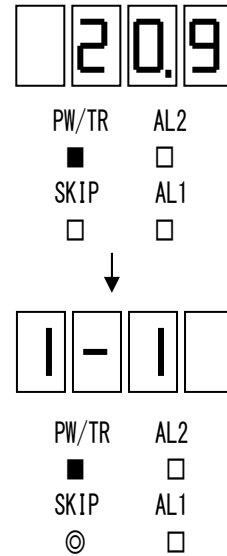
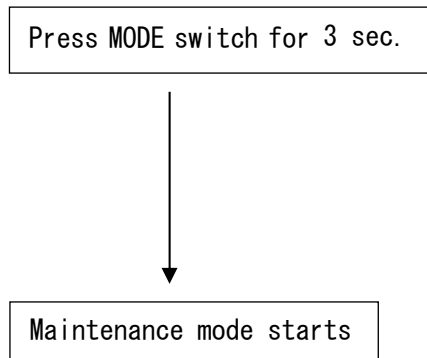

* Content of menu

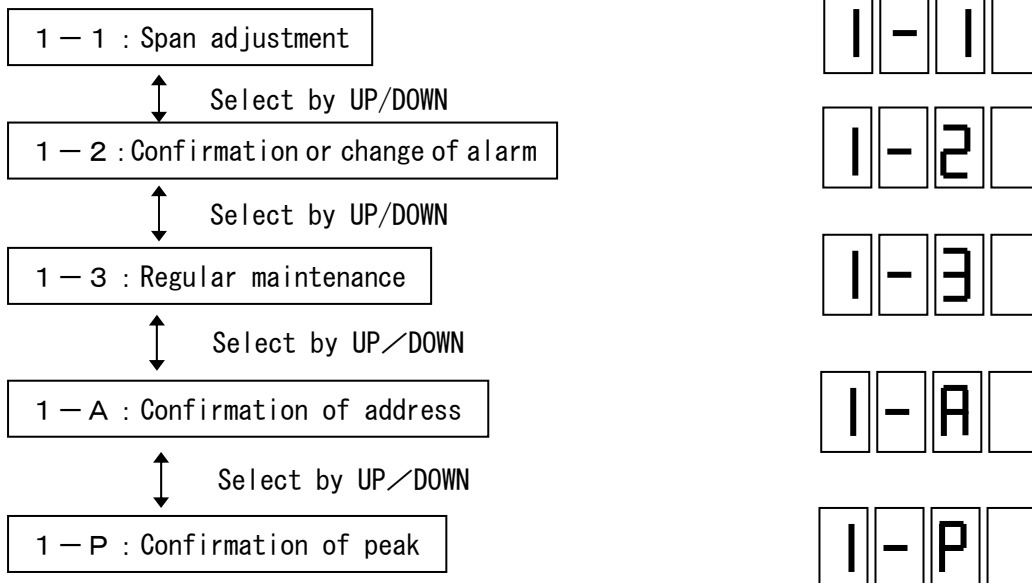

CAUTION

Do not operate 「1—3: Regular maintenance mode」 without our permission.
Please contact with our nearest agent or RIKEN KEIKI if it is required.

CAUTION

When maintenance mode starts at gas alarm, alarm contact and external output signal (gas alarm signal) will be cancelled.

5-5-2. Adjustments

5-5-2-1. Span adjustment (For prevention of oxygen deficiency)

*** NOTE**

When maintenance mode is started, the suppression function (Indications within 20.9 ± 0.4 vol% is displayed as 20.9 vol%) is cancelled.

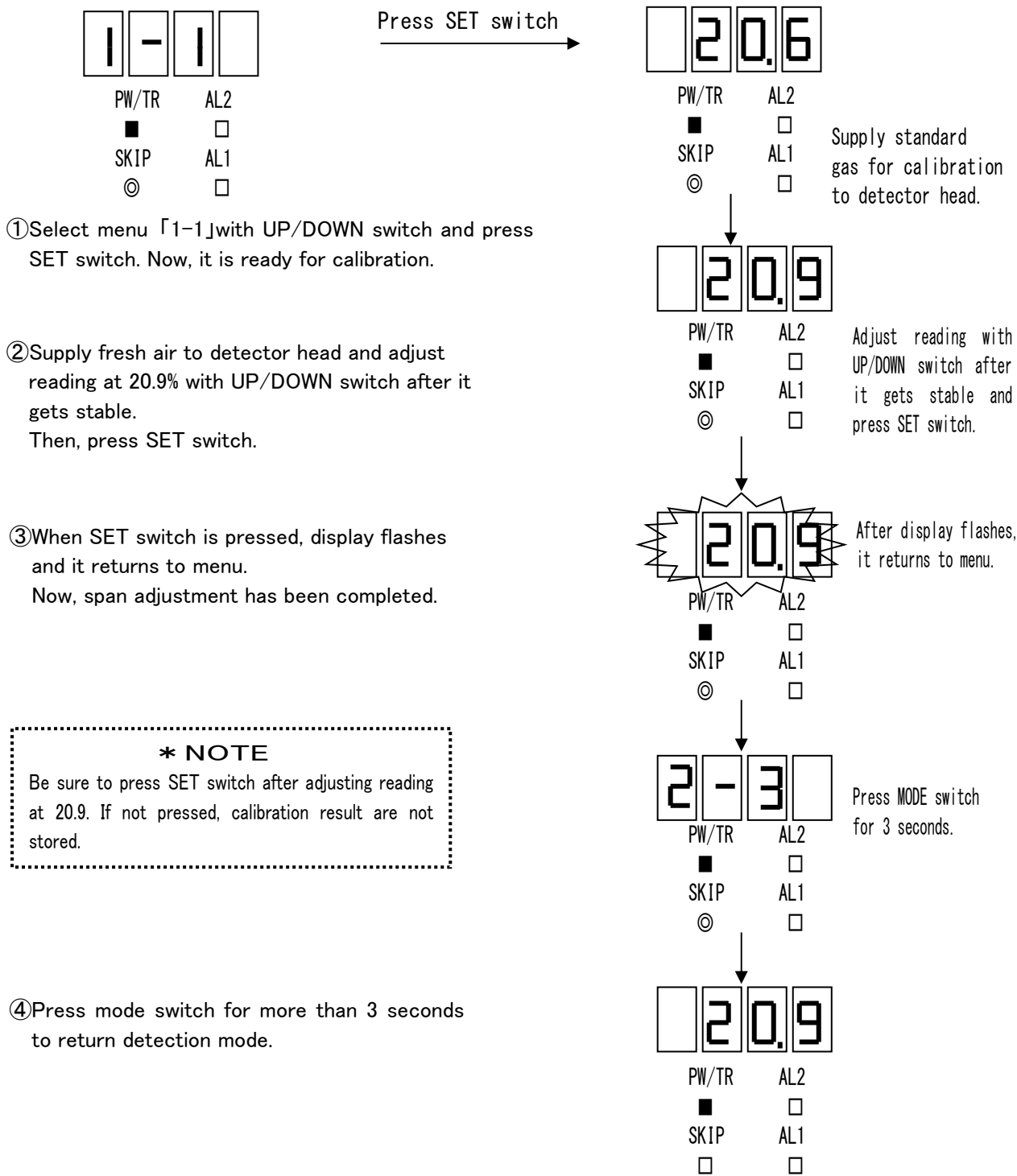

5-5-2-2. Zero adjustment (For general detection)

WARNING

In case that the alarm is set below 20.9vol%, when disconnect at gas inlet side to supply the gas for zero adjustment, be sure to make it in maintenance mode. When disconnect piping in detection mode, alarm will be triggered. Announce it to respective department beforehand to avoid abnormal actions (Output signal, alarm contact).

* NOTE

When making zero adjustment with the gas for zero adjustment, adjust reading after it gets stable.

① Prepare zero gas 「Nitrogen(N2)」

② Press MODE switch to enter into maintenance mode.

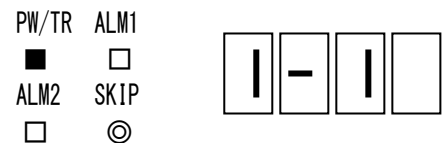

③ Press TEST/SET switch, and display shows indication valve. Supply zero gas (N2) for 3 seconds and then, adjust reading at 「0.00」by pressing TEST/SET switch.

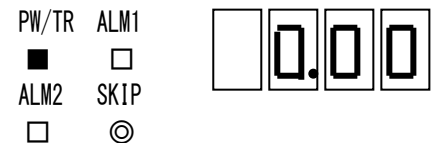
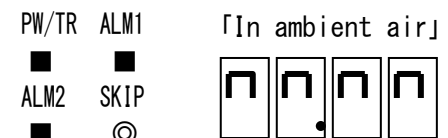

④ After adjustment, press MODE switch to return menu.

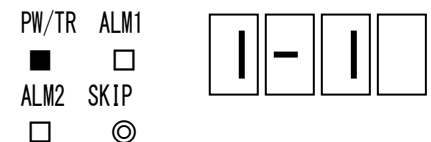

⑤ To return detection mode, press MODE switch further for over 3 seconds, and SKIP mode light turns off which shows detection mode.

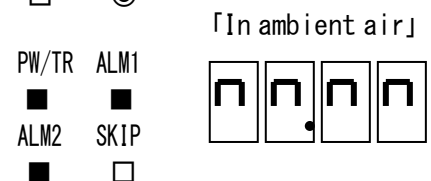

WARNING

Be sure to return detection mode (only PW/TR light illuminates) by pressing MODE switch after completion of adjustment.

CAUTION

Gas alarm is not triggered except in detection mode.
When leave it alone on maintenance mode, this returns to detection mode automatically after 10 hours.

5-5-3. Confirmation of alarm level

This section is used to check preset alarm levels.

- Press UP switch in detection mode, and the 1st alarm level (AL1) is shown. Press DOWN switch in detection mode, the 2nd alarm level (AL2) is shown.

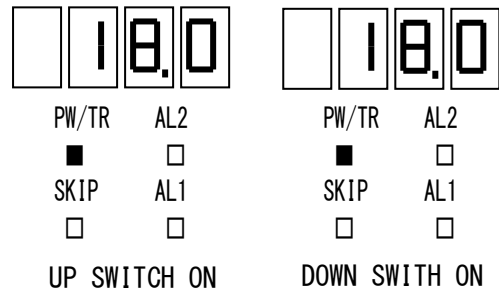

5-5-4. Change of alarm level

This section is used to change alarm levels.

- Press MODE switch for over 3 seconds, and maintenance mode starts.

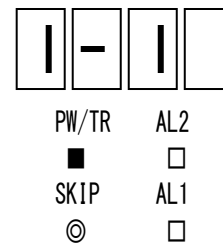

- Select「1-2」with UP/DOWN switch.

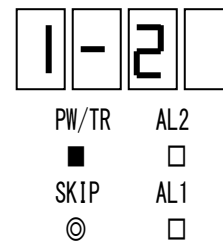

- When press SET switch, 1st alarm level (AL1) can be checked. When press it again, 2nd alarm level (AL2) can be checked.

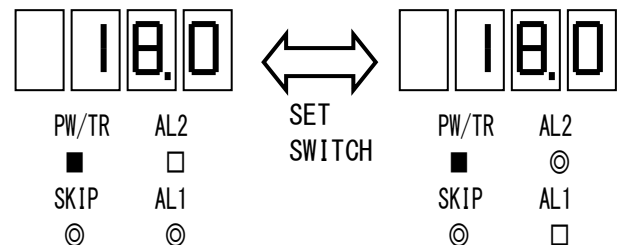

- To change alarm levels (AL1,AL2), adjust them with UP/DOWN switch and then, press SET switch.

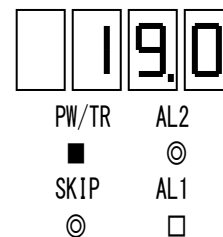

- To return detection mode, press MODE switch for over 3 seconds, and SKIP mode light turns off which shows detection mode.

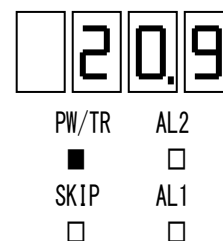

CAUTION

Gas alarm is not triggered except in detection MODE.
When leave it alone on maintenance mode, this returns to detection mode automatically after 10 hours.

5-5-5. Confirmation of peak hold level

The highest reading level is held if gas concentration reaches preset alarm level in detection mode.

- ① Press MODE switch for above 3 seconds to start maintenance mode.

1 - 1

- ② Select 「1 - P」 with UP/DOWN switch.

1 - P

- ③ Peak hold level can be checked with SET switch.

16.0

- ④ Press SET switch for above 3 seconds to release peak hold level.

16.0



1 - P

- ⑤ Press SET switch to check whether it is cancelled or not. The starting point of peak hold for OX-592 (0-25vol% range) is 25vol%.

25.0

- ⑥ To return detection mode, press MODE switch for above 3 seconds, and SKIP light turns off to show detection mode.

20.9

CAUTION

Gas alarm is not triggered except in detection MODE.
When leave it alone on maintenance mode, this returns to detection mode automatically after 10 hours.

5—5—6. Alarm test

This section is used to confirm alarm light, alarm buzzer, alarm relay contact and transmission condition to the outer equipment by giving same gas concentration signal (4–20mA) output.

WARNING

When make alarm test, (transmission test), announce it to respective department beforehand. Carry it out after making proper treatment (External signal output, alarm contact).

① Press SET switch for above 3 seconds to start alarm test mode. When it gets to alarm test mode, both SKIP light and display flash.

② Decrease the reading with DOWN switch. When it reaches the first alarm level, AL1 light flashes and buzzer sounds (first alarm contact works). When it reaches the second alarm level, AL2 light flashes and buzzer sounds (2nd alarm contact works).

③ To stop the buzzer sound, press RESET switch. In this occasion, alarm light changes to steady light and it becomes self reset mode. To decrease reading below alarm level with UP switch, alarm light and alarm contract are cancelled.

④ Press SET switch for above 3 seconds, and it returns detection mode. SKIP light turns off which shows detection mode.

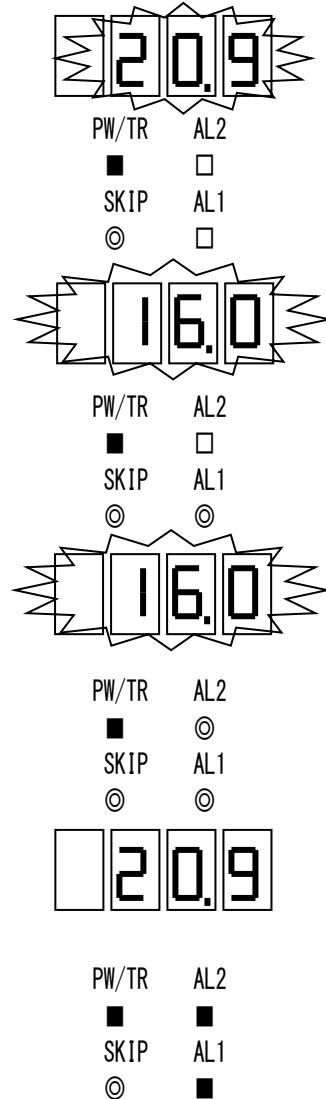

5—6. How to finish operation

When finish this operation, turn off switch of this unit first and turn off the main power (DC24V).

WARNING

- When finish this operation, do it after making point skip with upper system (Centralized system).
- When finish this operation, check the external output and function of outer equipment to be connected with external alarm contact. Then, judge whether power can be shut off or not. When alarm contact is set on excitation (option), alarm contact works when make power (DC24V) off.

6. KIND OF ALARM AND ITS FUNCTION

6—1. Kinds of alarm

There are two kinds of alarm such as gas alarm and trouble alarm.

- Gas alarm : When detection gas reaches preset alarm level or exceeds it, this starts an alarm.
《Latched mode → Self reset after reset operation.》

* NOTE

Both 1st and 2nd alarms are set at 18 vol% (Oxygen deficiency alarm version) as standard.
This unit is set an alarm delay circuit at 2 seconds to prevent wrong operation.

- Trouble alarm : Abnormal condition in this unit is detected and give a trouble alarm.
Except system trouble “E-00”, it is non-latched mode.
When return to normal from trouble condition, it starts again from the action of initial clear after power on see section [9.TREATMENT AT ABNORMAL CASE].

6—2. Gas alarm

6—2—1. Gas alarm action

(1) Display

① Gas concentration

When exceeds detection range (Over scale), LED shows “ $\cap \cap \cap \cap$ ”.

② Power light (Power : Green)

It keeps steady light.

③ Alarm light (AL1 : Orange)、(AL2 : Red)

There are two alarm levels. When reading reaches each preset alarm level, or exceeds each preset alarm level, this starts flashing and then returns to continuous lighting after reset operation, (Standard).

(2) External output

① 4~20mA output

Electric current proportional to gas concentration is output. In case of over scale, the maximum out is 22mA.

② Alarm contact

When gas concentration reaches preset alarm level or it exceeds preset alarm level, relay contact works.

Alarm relay contact is a latched mode. It returns self-reset mode when gas concentration increases above preset level after reset operation.

※Alarm pattern is shown in the attached sheet.

6—2—2. Counteraction at gas alarm

Reaction to leak gas

The counteraction at gas alarm shall follow to the client rule and immediate action shall be required. Generally, following action is taken.

- ① Confirmation of indication value.

* NOTE

Instantaneous oxygen deficiency condition may return normal condition at confirmation time. Except gas alarm, it gets alarm condition temporarily by noise or any other accidental conditions.

- ② Based on oxygen deficiency control concentration, it keeps the safety by keeping away people from monitoring area.
- ③ When oxygen deficiency concentration display is continued, ventilate around detector head and confirm that oxygen concentration returns normal value.
- ④ Suppose that the oxygen deficiency condition is to remain and provide yourself with protection attire and tool away from danger, go to the leak site and check the gas residual condition by portable gas detector.
- ⑤ After checking that there is no danger, the treatment for gas leak shall be taken.

6—2—3. Gas alarm possibility except the case of gas detection

It may respond to interference gas

For interference gases, contact the nearest agent or RIKEN KEIKI.

It may be caused by drifting due to the change of long time elapsed sensor

Check the reading by daily check and make calibration through authorized service agent whenever necessary.

It may be caused by the noise generated from spherical machine

Revision of installation location, wirings and the addition etc. of noise measure parts between instrument and detector shall be required. This specific measures shall differ from the condition of each site.

It may receive a temporarily noise such as by thunder lightning etc.

When the cause and effects are understood, the measure for surge according to the condition can be taken.

7. MAINTENANCE AND CHECK

This is an important security and safety. To maintain the security and enhance the reliability of safety, the reliability of safety and the regular maintenance check for it shall be absolutely necessary.

7 — 1 . Frequency of maintenance and check items.

7 — 1 — 1 . Daily check

This is the check items carried out by customer.

① Check of PW/TR light.

In normal operation, the light is at on condition.

② Check of LED reading

Check that LED reading is “20.9” for oxygen deficiency version and “0.0” for general detection respectively.

If it is not the above, check that gas is free around detector head and make span adjustment in maintenance mode at detector head side.



CAUTION

For the accurate span adjustment, check it by 「1-1. Span adjustment」 of maintenance mode.

③ Alarm test

Check that the alarm light flashes and buzzer sounds.



CAUTION

For the alarm test, refer to 「5-5-6. Alarm test」.

7 — 1 — 2 . Regular maintenance check

The following items shall be checked at regular check.

- ① Daily check
- ② Cleaning of this unit
- ③ Adjustments
- ④ Function check
- ⑤ Parts replacement
- ⑥ Others

7 — 2 . Maintenance contract for regular check

To maintain the safety operation of the unit, it is recommended to keep the maintenance contract with service agent for regular maintenance, adjustment and overhaul etc including the gas sensitivity adjustment.

For the detail of maintenance contract, contact our nearest service agent or RIKEN KEIKI.

7 — 3. Replacement of sensor and parts



CAUTION

For replacement of sensors and parts etc, contact our service agent or RIKEN KEIKI.

7 — 4. Treatment when operation is stopped or its installation place is moved.

7 — 4 — 1. Stop at normal operation

Make the power switch off on the front panel.
Make the power (DC24V) off at the supply side.

7 — 4 — 2. Installation when move its place

When move its place, refer to 「4-3. Installation place」 about its moving place. Then, for wiring refer to 「4-6. Wiring」.



CAUTION

When move its installation place, be sure to make gas calibration. The re-adjustment work including gas calibration shall be requested to contact our service agent or RIKEN KEIKI.

7 — 5. Storage and treatment when not use for a long time

This model must be stored under the following environmental conditions.

- In a dark place under the normal temperature and humidity away from direct sunlight.
- In a place where gases, solvents or vapors are not present.



CAUTION

- When re-use it, be sure to make gas calibration.
- The re-adjustment and parts replacement etc including the gas calibration shall be contacted to our nearest agent or RIKEN KEIKI.

8. SCRAP OF PRODUCT AND SENSOR

Scrap of products

- Regarding indicator/alarm unit and detector head complete, treat it in the same as industrial scrap (Non-flammable goods).

9. MEASURES AT AN ABNORMAL CASE

9-1. Trouble alarm

Flashing of PW/TR light

- When PW/TR light is flashing, it is the condition that the following trouble may be caused.
Research its cause and take an appropriate action.
- The output from the unit at trouble shall be as follows.
OX-592 (4~20mA output) : Fixed at 0.5mA

LED display	Trouble content	Main cause
E-00	System trouble	Memory trouble in the unit.
E-01	Connection trouble of detection head	Detector head disconnection, sensor disconnection, sensor cable disconnection.

9-2. Counteraction at trouble alarm

When any trouble was found on this unit and detector head, contact our nearest agent or RIKEN KEIKI.

9-3. Before it is thought to be trouble

It may be originated from disconnection and short circuit between units.

- Check the wirings including peripheral equipment as well as detector head.
- Re-check the detection system and contact our nearest agent or RIKEN KEIKI.

There is the case of electrical line trouble such as shut-off of power.

- This will be treated by the re-check of stand-by battery, electrical line filter, insulation transformer etc or those addition.

9-4. Trouble shooting

(1) PW/TR light does not illuminate

<Cause and action>

- Is it OK with power cable connection?
Connect power cable.
- Is fuse disconnected?
Search the cause of disconnection and replace it after making counter-measures.
- Is power voltage normal?
Supply the rating power voltage.
- Is this power switch turned on?
Make power switch ON.

(2) Abnormal performance

<Cause and action>

- Sudden surge noise can be considered. When recover it, turn off the power and turn on the power again for re-start of operation.
When such takes place oftentimes, take an appropriate action for noise.

(3) No calibration available

<Cause and action>

- Is the calibration gas concentration correct?
Prepare the appropriate calibration gas.
- There is the possibility for sensor sensitivity drop.
The sensor replacement is required.

(4) PW/TR light flashing

① System trouble 「E-00」

<Cause and action>

- Memory trouble inside of indicator/alarm unit.

Contact our nearest agent or RIKEN KEIKI.

② Sensor connection trouble 「E-01」

<Cause and action>

- Non-connection of sensor, contact failure of connector and disconnection of sensor cable.
 - Check “whether sensor is connected” or “the sensor cable connector is connected to the sensor.”
- If can not be recovered, contact our nearest agent or RIKEN KEIKI.

(5) Fuse disconnection

<Performance>

- This unit can not work.

<Cause and action>

- The trouble of this unit or trouble of external power source can be considered. Search this cause and after taking its measures, replace the fuse with the designate one.

*** NOTE**

The fuse rating for this unit is “250V/1A T”.

10. DEFINITION OF TERMS

External output signal

External output is as follows.

Gas Concentration signal output : current transfer model (4-20mA)

Alarm contact output : ① Gas alarm (AL1)
② Gas alarm (AL2)
③ Trouble alarm

Calibration

By using calibration (standard) gas etc, it seeks for instrument reading, display value or set value and true value.

Maintenance mode

When make maintenance of this unit, shut off the alarm and the output of signal showing the maintenance mode condition is displayed on the external output signal.

By this, the maintenance is carried out independently on this unit.

Press MODE switch for 3 seconds, and the maintenance mode starts.

Initial clear

The reading will be unstable for a few seconds after power on. In this moment to prevent the error of running, the alarm contact shall be cut off. Then, signal output showing initial clear condition is given on external output.

Alarm delay time

To prevent the alarm error by noise intruded from the outside, this is the function to suspend the running temporarily.

1 1 . PRODUCT SPECIFICATIONS

1 1 — 1 . Specifications

Detectable gas	Oxygen
Detection principle	Galvanic cell type
Gas concentration display	LED(4digits•7segments)
Power indication	PW/TR lamp lighting(green)
Gas alarm type	Two-level alarm(H-HH or L-H, L-LL)
Gas alarm indication	1st: AL1 lamp blinking or lighting(orange) 2nd: AL2 lamp blinking or lighting(red)
Gas alarm action	Latched or Non-latched, Lock-in
Gas alarm contact	Each no-voltage contact 1a or 1b(contact output for each alarm) Non-exciting at normal(exciting at alarm) or exciting at normal(non-exciting at alarm)
Trouble alarm•Self diagnosis	System failure/detector head connection failure
Trouble alarm indication	PW/TR lamp blinking/Indicates error codes
Trouble alarm action	Auto-recover
Trouble alarm contact	No-voltage contact 1a or 1b Non-exciting at normal(exciting at alarm) or exciting at normal(non-exciting at alarm)
Transmission scheme	Analog transmission
Specification of transmission	DC4~20mA(non-isolated•load resistance less than 300Ω)
Gas detector head signal	DC4~20mA
Cable between detector	CVVS worth of shield cable•2-core
Distance between detector	Max 1.25km with CVVS 1.25mm ² cable
Various functions	Alarm delay/Suppression/ Peak hold/Alarm trend history
Power requirement	DC24V±10%
Power consumption	Max 5W(Including detector head.) or Max 8VA(with multi-unit case)
Initial clear time	Approx. 25 second
Operating temperature	0~40°C(non-rapidly-vary)
Operating humidity	10~90%RH(non-condensing)
Structure	Housing type for the case front identification card type(put into Single case or Multi case)
Outer dimension	Approx. 36(W) × 72(H) × 134(D)mm
Weight	Approx. 0.10kg (Unit only)

1 1 — 2 . Product composition

Standard compositions

- Indicator/alarm unit Model OX-592
- Operating instruction manual...1 vol.
- Spare fuse...Depends on ordered quantity of the unit.

1~10 units	1 pce
11~20 units	2 pcs
21~50 units	3 pcs
51 units and above	4 pcs



EU-Declaration of Conformity

Document No.: 320CE21051



We, RIKEN KEIKI Co., Ltd. 2-7-6, Azusawa, Itabashi-ku, Tokyo, 174-8744 Japan declare under our sole responsibility that the following product conforms to all the relevant provisions.

Product Name: INDICATOR/ALARM UNIT
Model: OX-592

Council Directives		Applicable Standards
2014/30/EU	EMC Directive	EN 50270:2015
2011/65/EU	RoHS Directive	EN IEC 63000:2018

Place: Tokyo, Japan

Date: Sep. 22, 2021

Takakura Toshiyuki
General manager
Quality Control Center