



Gas Detector

TP-70DGII

Operating Manual

RIKEN KEIKI Co., Ltd.

2-7-6 Azusawa, Itabashi-ku, Tokyo, 174-8744, Japan

Phone : +81-3-3966-1113

Fax : +81-3-3558-9110

E-mail : intdept@rikenkeiki.co.jp

Web site : <https://www.rikenkeiki.co.jp/>

Contents

1. Outline of the Product	2
1-1. Preface	2
1-2. Purpose of use	2
1-3. Definition of DANGER, WARNING, CAUTION and NOTE	2
1-4. Method of confirmation for CE/UKCA marking type	3
2. Important Notices on Safety	4
2-1. Danger cases	4
2-2. Warning cases	4
2-3. Precautions	6
3. Product Components	7
3-1. Main unit and standard accessories	7
3-2. Outline drawing	8
3-3. Names and functions for each part	8
3-4. Block diagram	13
4. How to Use	15
4-1. Before using the gas detector	15
4-2. Precautions for installation sites	15
4-3. Precautions for system designing	17
4-4. How to wire	19
4-5. How to Tube	23
5. How to Operate	24
5-1. Preparation for start-up	24
5-2. Basic operating procedures	25
5-3. How to activate the gas detector	25
5-4. Modes	28
5-5. Detection mode	29
5-6. Alarm test mode	30
5-7. User mode	31
5-8. How to exit	35
6. Operations and Functions	36
6-1. Gas alarm activation	36
6-2. Fault alarm activation	38
6-3. External output operation	39
6-4. Other functions	41
7. Maintenance	44
7-1. Maintenance intervals and items	44
7-2. Regular maintenance mode	46
7-3. Calibration method	65
7-4. Other adjustments/cleaning method	68
7-5. How to replace parts	69
8. Storage, Relocation and Disposal	71
8-1. Procedures to store the gas detector or leave it for a long time	71
8-2. Procedures to relocate the gas detector or use it again	71
8-3. Disposal of products	72
9. Troubleshooting	73
10. Product Specifications	77
10-1. List of specifications	77
10-2. List of accessories	78
10-3. Detection principle	79
11. Definition of Terms	81

1

Outline of the Product

1-1. Preface



Thank you for choosing our gas detector TP-70DGII. Please check that the model number of the product you purchased is included in the specifications on this manual.

Non-compliance with safety precautions in use of electrical products may lead to fire or bodily injury. This manual explains how to use the gas detector and its specifications. It contains information required for using the gas detector properly. Not only the first-time users but also the users who have already used the product must read and understand the operating manual to enhance the knowledge and experience before using the gas detector.

1-2. Purpose of use

- This is a fixed type gas detector which detects leak of gases used in semiconductor factories, etc. The gas detector is a safety unit, not an analyzer or densitometer which performs quantitative/qualitative analysis/measurement for gases. Please fully understand the features of the gas detector before using it, so that it can be used properly.
- The gas detector detects abnormalities in the air caused by presence of gases or other reasons (leak) with the built-in gas sensor unit. The concentrations of detected gases are displayed on the character LCD.
- The built-in pump in the gas detector draws gas to perform gas detection.
- The gas detector head has two-step gas alarm contact and fault alarm contact.
- The gas detector outputs gas concentration in 4 - 20 mA or digital data (Ethernet).

1-3. Definition of DANGER, WARNING, CAUTION and NOTE

 DANGER	This message indicates that improper handling may cause serious damage on life, health or assets.
 WARNING	This message indicates that improper handling may cause serious damage on health or assets.
 CAUTION	This message indicates that improper handling may cause minor damage on health or assets.
NOTE	This message indicates advice on handling.

1-4. Method of confirmation for CE/UKCA marking type

The CE/UKCA marking is labeled on the detector in case of comply with CE/UKCA mark. Please confirm the instrument specification before using. Please refer Declaration of Conformity that is at the end of this manual if you have CE/UKCA marking type.

You can confirm instrument specification to see the CE/UKCA mark as follows.

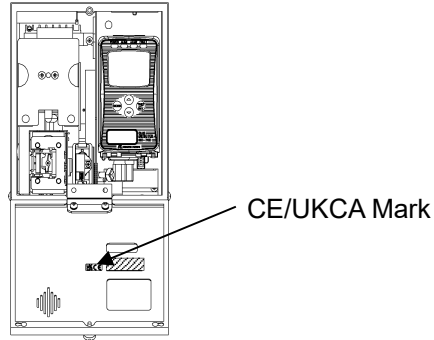

CE/UKCA mark label (Back of front cover)

2

Important Notices on Safety

2-1. Danger cases



DANGER

This is not an explosion-proof unit. Do not use the unit in place where combustible gases may exist.

2-2. Warning cases



WARNING

Power supply

Before turning on the gas detector, always check that the voltage is properly applied. Do not use an unstable power supply because it may cause malfunctions.

Need of grounding circuit

Do not cut the grounding circuit or disconnect the wire from the grounding terminal.

Defects in protective functions

Before starting the gas detector, check the protective functions for defects. When seeming defects are found in the protective functions, such as protective grounding, do not start the gas detector.

External connection

Before connecting the gas detector to a detection target or external control circuit, securely connect it to a protective grounding circuit.

Tube

The gas detector is designed to draw gases under the atmospheric pressure. If excessive pressure is applied to the sampling inlet and outlet (GAS IN, GAS OUT) of the gas detector, detected gases may be leaked from its inside, thus leading to dangers. Be sure that excessive pressure is not applied to the gas detector while used. Detected gases must be exhausted from the detected gas exhausting outlet (GAS OUT) on the back of the gas detector to which an exhaust tube is connected, to a point regarded as a safe place.



WARNING

Handling the sensor unit

Do not disassemble the electrochemical type sensor unit (ESU) because it contains electrolyte. Electrolyte may cause severe skin burns if it contacts skin, while it may cause blindness if it contacts eyes. If electrolyte is adhered on your clothes, that part on your clothes is discolored or its material is decomposed. If contact occurs, rinse the area immediately with a large quantity of water.

Zero adjustment in the atmosphere

When the zero adjustment is performed in the atmosphere, check the atmosphere for freshness before beginning the adjustment. If interference gases exist, the adjustment cannot be performed properly, thus leading to dangers when the gas leaks.

Operation in a gas

Do not operate the gas detector in a place where combustible/explosive gases or vapors are present. Operating the gas detector in such an environment will lead to extreme dangers.

Response to gas alarm

Issuance of a gas alarm indicates that there are extreme dangers. Take proper actions based on your judgment.

Fuse

To prevent fire, use a time lag fuse with the specified ratings (3.15A, 250V) for the gas detector. Turn the POWER switch OFF and disconnect the power plug from the outlet before replacing a fuse. Do not use an unspecified fuse or short-circuit the fuse holder.

Power cable

To operate the gas detector on 200 VAC system, prepare a power cable that supports 200 VAC. The power cable is provided only for the case that the power voltage is 100 VAC system (requested). The provided power cable supports 100 VAC.

Do not touch the pyrolyzer.

The inside of the pyrolyzer reaches high temperature. Do not touch it to avoid burn injury. Do not touch the pyrolyzer just after power-off because the inside of it is still hot.

2-3. Precautions



CAUTION

Do not use a transceiver near the gas detector.

Radio wave from a transceiver etc. near the gas detector or its cables may disturb indication reading. If a transceiver or other radio wave transmitting device is used, it must be used in a place where it disturbs nothing.

To restart the gas detector, wait for five seconds or more before doing it.

Restarting the gas detector in less than 5 seconds may cause errors.

Verify that the reading on the flow rate indicator corresponds to the specified flow rate before using the gas detector.

If it does not correspond to the specified flow rate, gas detection cannot be performed properly. Check whether the flow rate is unstable or lost.

Attach the provided filter before using the gas detector.

Before using the gas detector, attach the specified filter to prevent disturbances by possible gas adsorption or air dust.

A filter to be used varies depending on the gas to be detected. For more information on filters, please contact RIKEN KEIKI.

Also, the gas detector itself is not dust-proof. Take an appropriate measure such as attaching a protective cover when the gas detector is used in a dusty environment.

Observe the operating restrictions to prevent condensation inside the tube.

Condensation formed inside the tube causes clogging or gas adsorption, which may disturb accurate gas detection. Thus, condensation must be avoided. In addition to the installation environment, carefully monitor the temperature/humidity of the sampling point to prevent condensation inside the tube. In particular, when detecting a gas which is dissolved into water and corrodes contacted materials, such as a strong acid gas, the gas is undetectable and furthermore may corrode internal parts. Please observe the operating restrictions.

Do not use the external output of the gas detector to control other units.

This is not a control unit. It is not allowed to use the external output of the gas detector to control other units.

Do not disassemble/modify the gas detector, or change the settings if not necessary.

Disassembling/modifying the gas detector will invalidate the warranty of the performance. Changing the settings without understanding the specifications may cause alarm malfunctions. Please use the gas detector properly in accordance with the operating manual.

Never fail to perform a regular maintenance.

Since this is a safety unit, a regular maintenance must be performed to ensure safety. Continuing to use the gas detector without performing a maintenance will compromise the sensitivity of the sensor, thus resulting in inaccurate gas detection.

Do not install in places where equipment cannot be operated.

Do not install the unit in a place where it is difficult to operate so that it can be operated easily in case of emergency power-off and our maintenance equipment.

NT specification does not have CE marking

NT specification does not have CE marking. Therefore, it applies only to EA and EA(PoE) specifications.

3

Product Components

3-1. Main unit and standard accessories

<Main Unit>

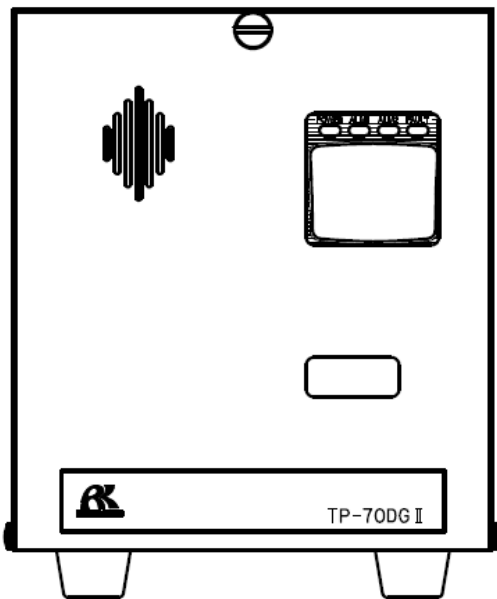

<Standard Accessories>

- Operating Manual
- Protective rubber cap (to be removed when using the gas detector)
- Dust filter
- Silica gel filter (when using the gas detector for C4F6/C5F8 detection)

3-2. Outline drawing

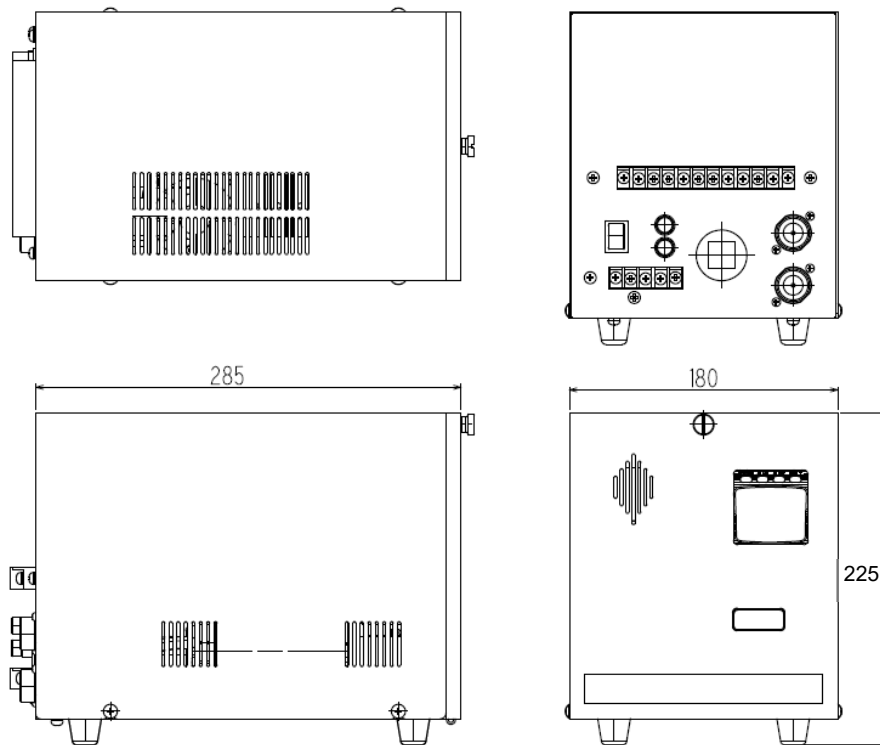

3-3. Names and functions for each part

<Components of the Gas Detector>

The gas detector consists of the following units.

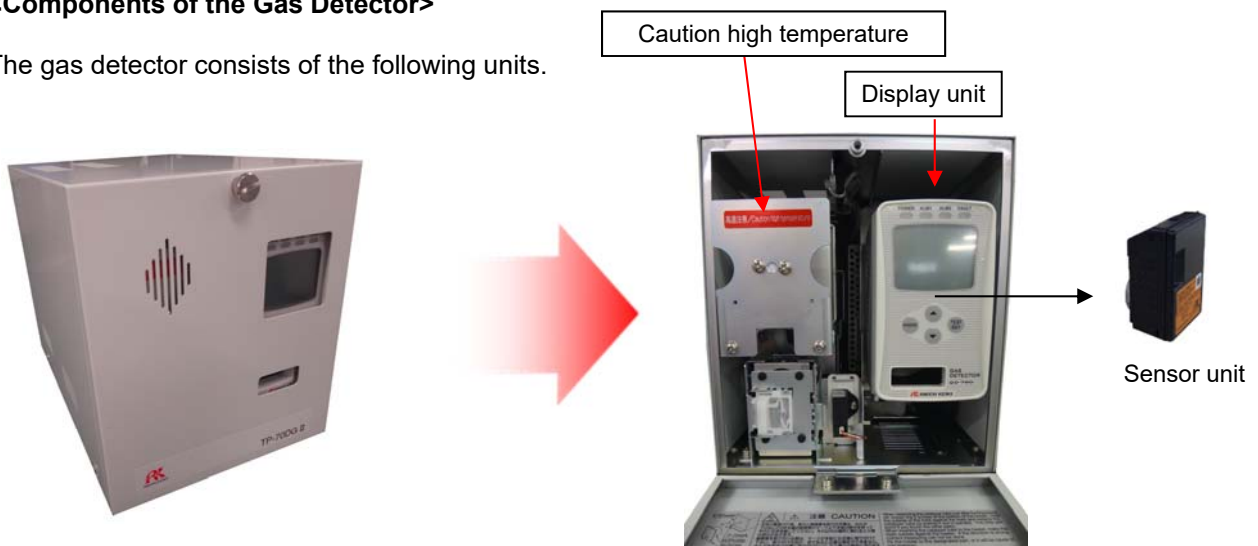

CAUTION

Each unit consists of precision parts. When a unit is detached, be careful not to drop it. Dropping the unit compromises its original performance or causes malfunctions. In addition, there is a risk of burns where high temperature caution stickers are affixed. Be careful not to touch it.

NOTE

The display unit is designed specifically for the gas detector. Do not use a similar product. It will not function normally.

<Exterior of Main Unit>

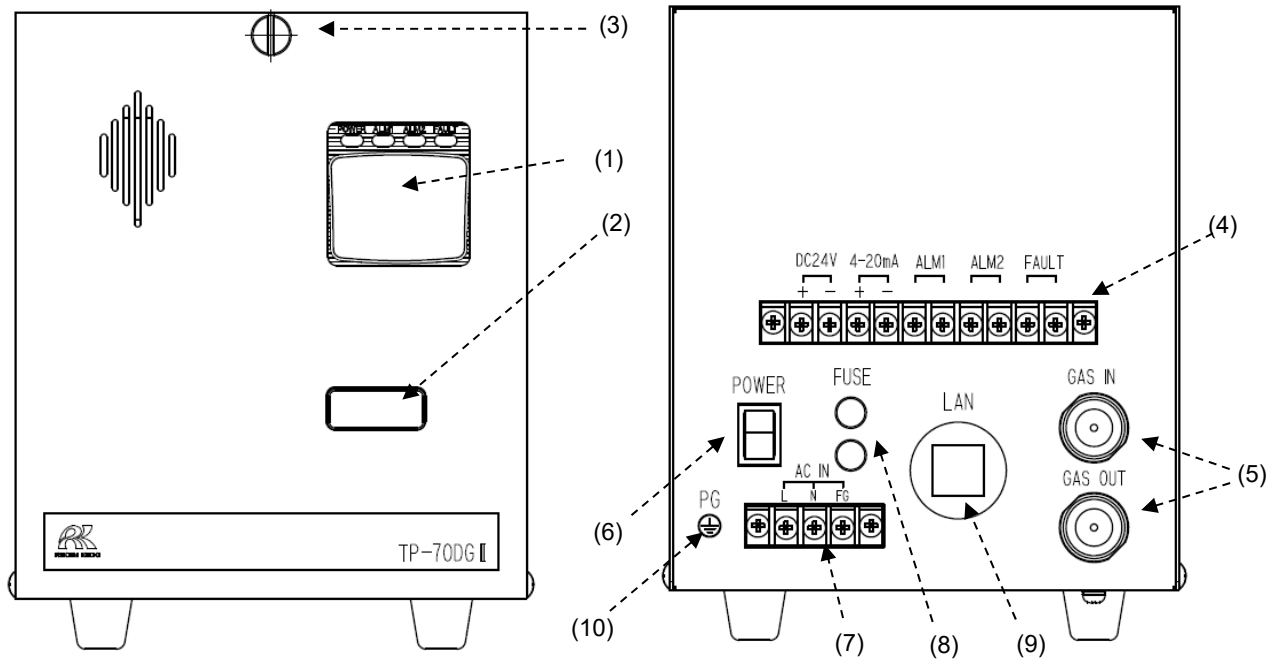

(1)	Display	Display the gas concentration and so on.
(2)	Sensor unit nameplate display window	The sensor unit nameplate can be checked from this window. You can identify the currently attached sensor unit.
(3)	Knurled screw	Fix the front cover. This is used to open/close the front cover.
(4)	External terminal plate	Connect cables for external signals (4 - 20 mA) and contacts.
(5)	Sampling gas inlet/outlet	GAS IN: Connect a sample gas suction tube. GAS OUT: Connect a sample gas exhaust tube.
(6)	Power switch	Main power switch. Turn the AC power ON/OFF.
(7)	Power terminal plate	Connect cables for power.
(8)	Fuse	Main fuse.
(9)	LAN connector	Connect a LAN cable.
(10)	Protective grounding	Protective grounding (CE marking specification only)

<Interior of Main Unit>

<Unit Panels and Character LCD>

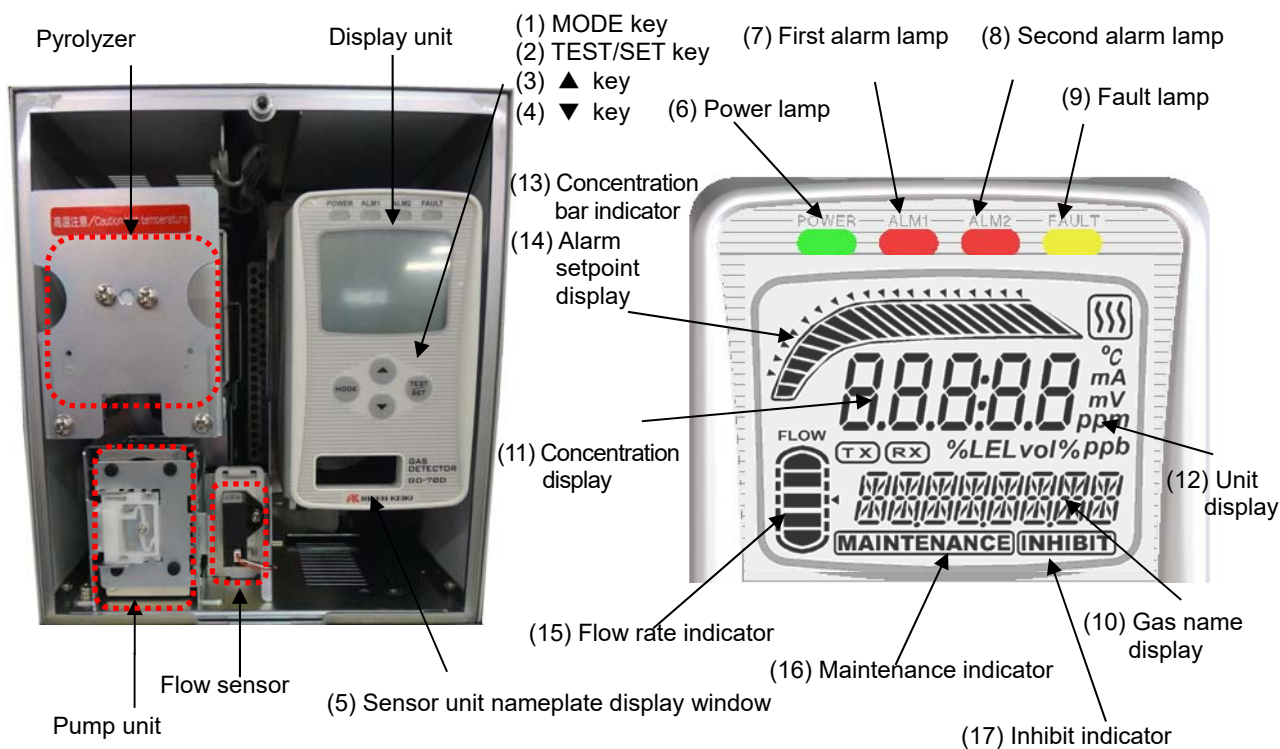

(1)	MODE key	Used to enter the maintenance mode. It is also used to cancel or skip in each mode. In the alarm test mode, it is used to reset an alarm.
(2)	TEST/SET key	Used to enter the test mode. It is used for value confirmation and so on in a specific mode.
(3)	▲ key	Used to switch screen or change a value (UP).
(4)	▼ key	Used to switch screen or change a value (DOWN). In the detection mode, it is used to reset an alarm.
(5)	Sensor unit nameplate display window	The sensor unit nameplate can be viewed through this window. You can identify the currently attached sensor unit.
(6)	Power lamp (POWER)	Display unit power lamp. It lights in green when the power is on.
(7)	First alarm lamp (ALM1)	First alarm lamp. It blinks or lights in red when the first alarm is reached.
(8)	Second alarm lamp (ALM2)	Second alarm lamp. It blinks or lights in red when the second alarm is reached.
(9)	Fault lamp (FAULT)	Fault lamp. It lights up in yellow when an abnormality is detected in the gas detector.
(10)	Gas name display	Displays a gas name in chemical formula, etc. (e.g. Silane = SiH_4)
(11)	Concentration value display	Displays the gas concentration and so on.
(12)	Unit display	Displays the unit according to the specification. (ppm, ppb, vol%, %LEL)
(13)	Concentration bar indicator	The detectable range (full scale = FS) is divided into 20 with bars. The increase in concentration is displayed in proportion to the full scale.
(14)	Alarm setpoint display	The alarm setpoints (AL1 and AL2) are indicated on the concentration bar.
(15)	Flow rate indicator	Displays the flow rate. The center of the bars means the normal suction flow rate of 0.5 L/min.
(16)	Maintenance display	Displayed during the maintenance mode. While this is displayed, the alarm contact is disabled.
(17)	Inhibit display	Displayed when the inhibition (point skip) is set.

<Detaching and Attaching Sensor Unit>

- Loosen the knurled screw that fixes the front cover of the main unit and open the cover.

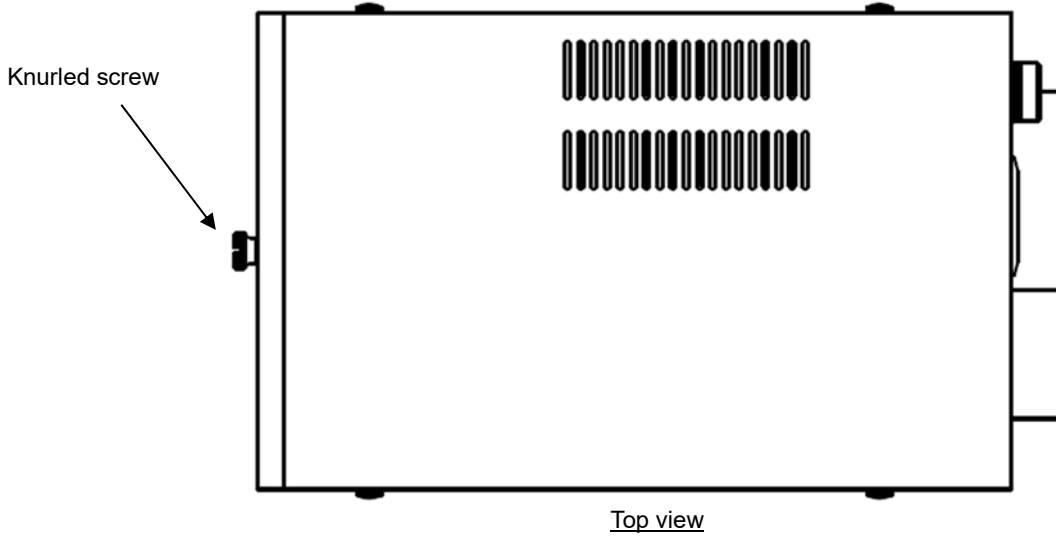

- Push the two buttons at the top of the display unit together to open the front cover. (Pushing only either one button cannot open the cover, but then pushing the other can open it.)



CAUTION

Turn the power off before detaching or attaching the sensor unit.

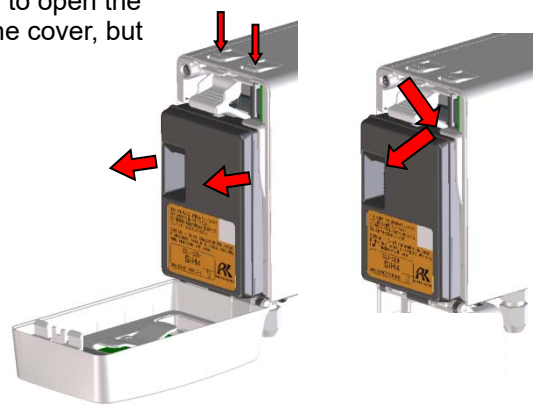

- Hold the convexed parts on both sides of the sensor unit and pull it out. If the sensor unit is hard to detach, insert a finger into the gap at the top right of the sensor unit and pull it out.
- When attaching the sensor unit to the main unit, thrust it onto the main unit and make sure that the sensor unit is securely fixed, otherwise it might come off.
- After replacing the sensor unit, close the front cover of the display unit. Be sure to check the click of the front cover to fix it properly, otherwise it might open again.
- Close the front cover of the main unit and tighten the knurled screw.

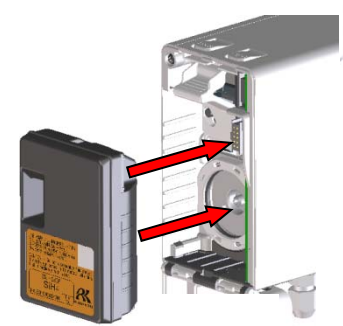

<Detaching and Attaching Pump Unit>

Open the front cover of the main unit.

Slide the tab in the direction of the arrow (toward the inside of the main unit) to open/close the pump unit cover.

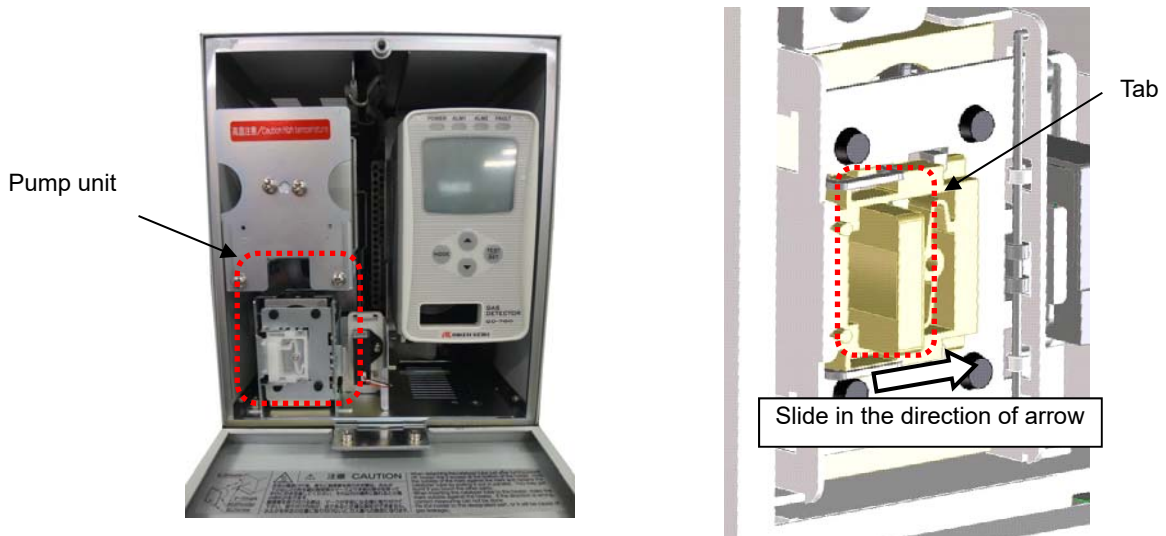

With the pump unit cover opened, the pump located inside can be pulled out.

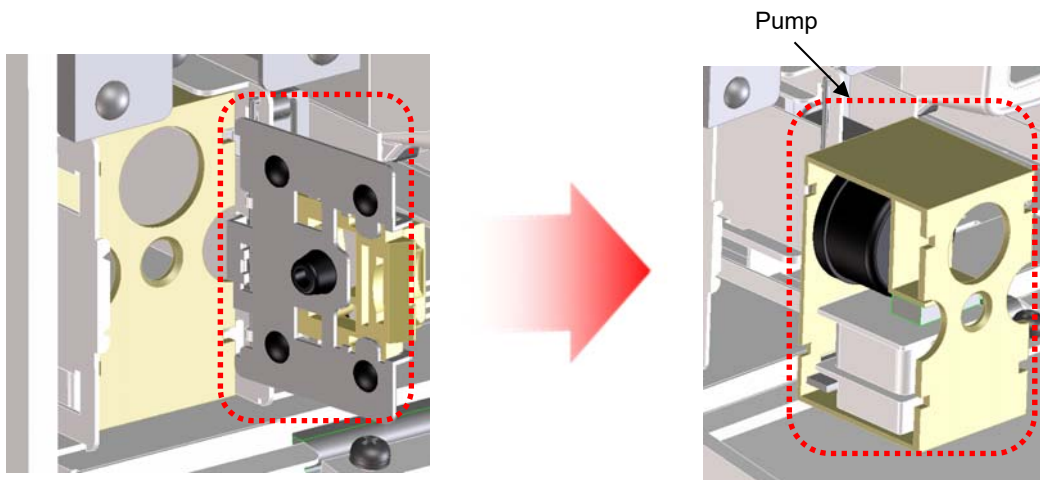

Attach the pump in the reverse order.

After attaching the pump, check that the pump unit cover is fixed securely.

And as the connecting point (flow path) of the pump is greased, be sure to check for any dust.

**CAUTION**

If the pump and pump unit cover are not attached properly, the pump may malfunction.

<How to Use Sensor Unit>



CAUTION

- The sensor unit must be handled carefully to ensure quality as safety unit. When the sensor unit is stored, a dedicated warehouse and power equipment for the sensor unit are needed. In principal, the sensor unit must not be detached from the gas detector when it is handled or stored. We will take care of your sensor unit.
- Be sure that the sensor unit is not installed improperly.
If a sensor unit of different specification or principle from the one shipped from the manufacturer is attached, a message will be displayed on the LCD of the gas detector ("C-02"). If the message is displayed, check the specifications of the sensor unit.
- After the sensor unit is replaced, always perform a calibration (zero adjustment and span adjustment).

Electrochemical Type (ESU)



- Do not disassemble the sensor unit because it contains electrolyte. If contact occurs, rinse the area immediately with a large quantity of water.
- The sensor unit identifies the direction. Put the sensor unit in the dedicated case while handling it. Do not place it on its side or upside-down.
- When a new sensor unit is installed, it must be warmed up. Although warm-up time is different depending on the type of the installed sensor, it is recommended that warm-up should be performed for three hours or more. Please contact RIKEN KEIKI for more information.
- The sensor unit must be stored in a clean, cool and dark place away from direct sunlight. Some types of the sensor units cannot be stored together with other units. Please contact RIKEN KEIKI for more information.

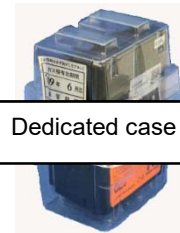

Dedicated case

3-4. Block diagram

<Tubing Diagram>

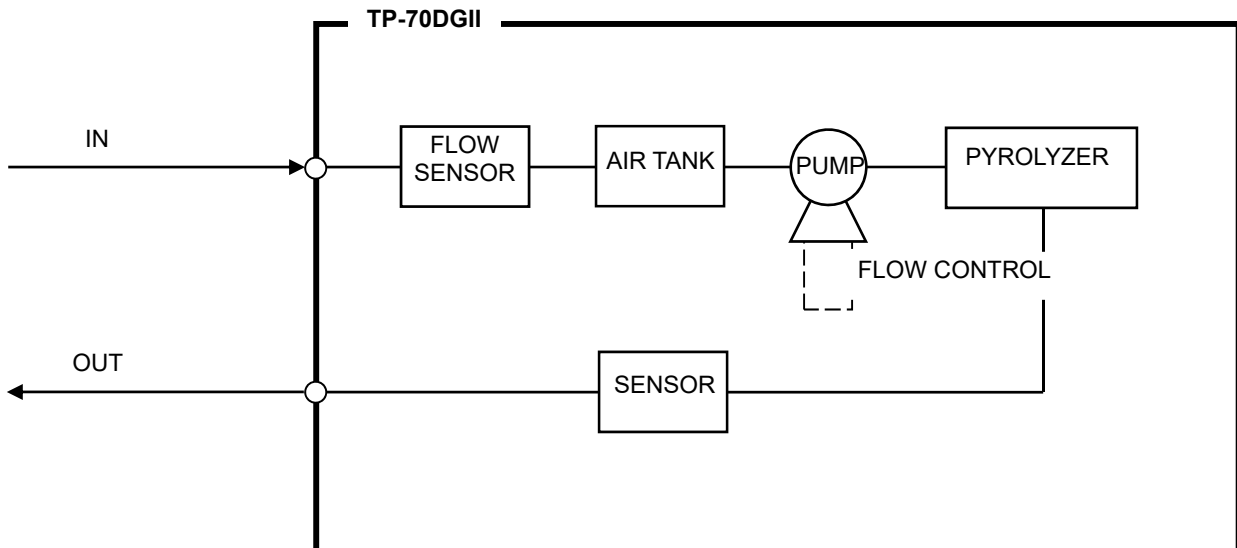

<Electric Diagram>

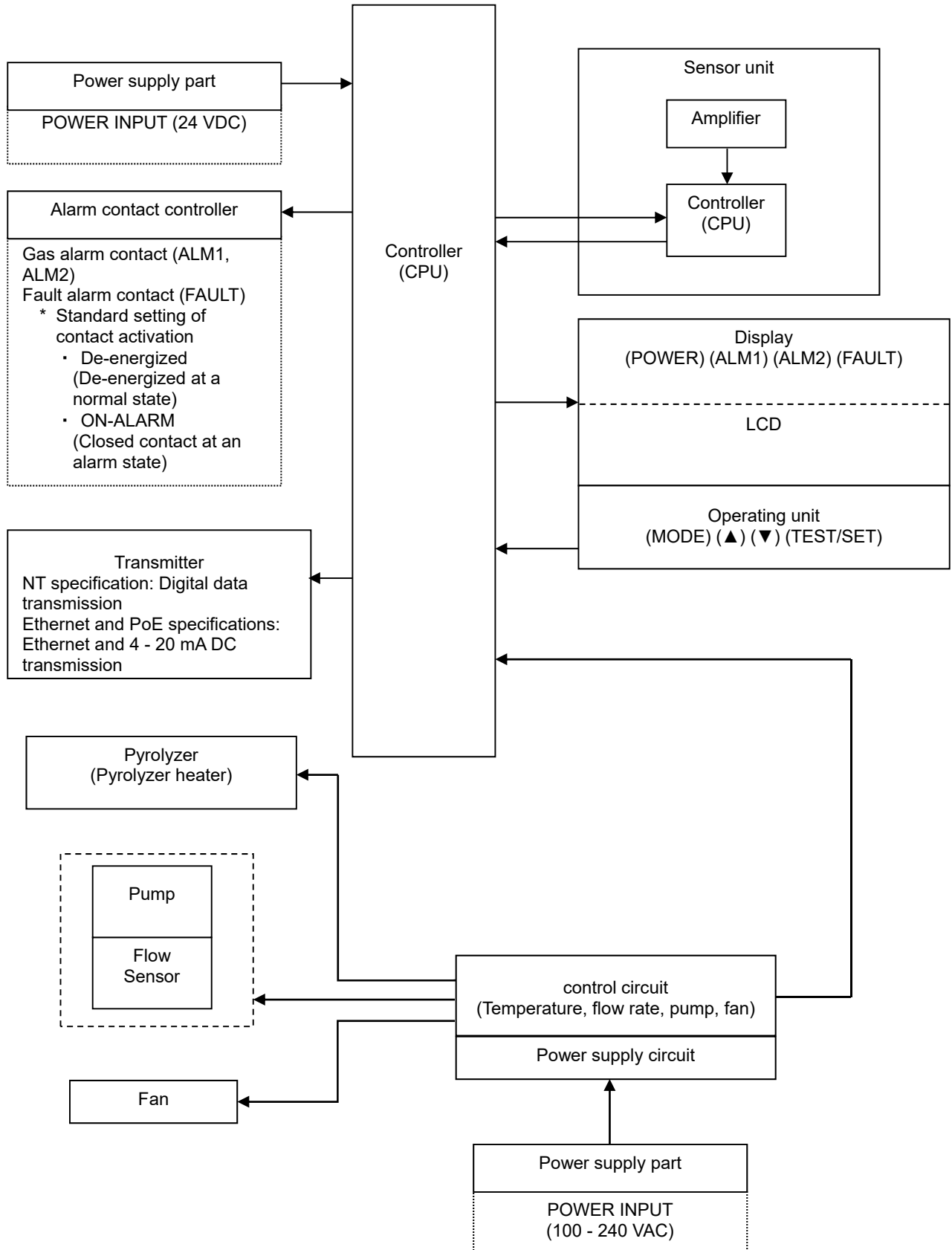

4

How to Use

4-1. Before using the gas detector

Not only the first-time users but also the users who have already used the gas detector never fail to follow the operating precautions.

Ignoring the precautions may damage the gas detector, resulting in inaccurate gas detection.



CAUTION

After you received the gas detector, start using it within the specified operation start limit of the sensor unit.

4-2. Precautions for installation sites



CAUTION

This is a precision device. Because the gas detector may not provide the specified performance in some places (environments), check the environment in the installation site, and then take appropriate actions if necessary.

Because the gas detector plays an important role for safety and disaster prevention, you must install as many units of the gas detector as needed in appropriate points.

Because points where gases leak and remain easily are different depending on the types of gases and the working areas, please decide carefully installation sites and the number of units to be installed.

Do not install the gas detector in a place with vibrations or shocks.

The gas detector consists of sensitive electronic parts. The gas detector must be installed in a stable place without vibrations or shocks and it cannot drop.

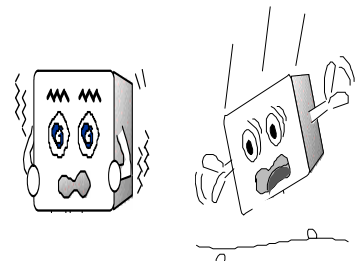

Do not install the gas detector in a place exposed to water, oil or chemicals.

When selecting installation points, avoid a place where the gas detector is exposed to water, oil or chemicals.

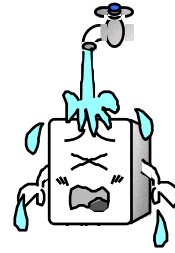

Do not install the gas detector in a place where the temperature drops below 20°C or rises over 40°C.

The operating temperature of the gas detector is 20 to 40°C. The gas detector must be installed in a stable place where the operating temperatures are maintained and do not change suddenly.

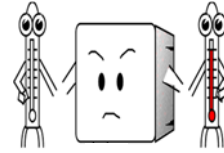

Do not install the gas detector in a place exposed to direct sunlight or sudden changes in the temperature.

Avoid a place where the gas detector is exposed to direct sunlight or radiant heat (infrared rays emitted from a high-temperature object), and where the unit temperature changes suddenly. Condensation may be formed inside the gas detector, or the gas detector cannot adjust to sudden changes in the temperature.

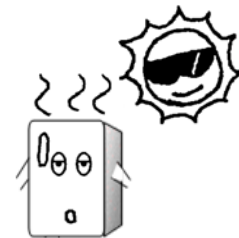

Keep the gas detector (and its cables) away from noise source devices.

When selecting installation points, avoid a place where high-frequency/high-voltage devices exist.

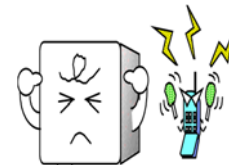

Do not install the gas detector in a place where maintenance of the gas detector cannot be performed or where handling the detector involves dangers.

Regular maintenance of the gas detector must be performed.

Do not install the gas detector in a place where the machinery must be stopped when maintenance is performed in its inside, where parts of the machinery must be removed to perform maintenance, or where the gas detector cannot be removed because tubes or racks, etc. prevent access to it. Do not install the gas detector in a place where maintenance involves dangers, for example, near a high-voltage cable.

Do not install the gas detector in machinery which is not properly grounded.

Before installing the gas detector in machinery, the machinery must be grounded properly.

Do not install the gas detector in a place where interference gases exist around it.

The gas detector must not be installed in a place where interference gases exist around it.

4-3. Precautions for system designing



CAUTION

- An unstable power supply and noise may cause malfunctions or false alarms. The descriptions in this section must be reflected on the designing of a system using the gas detector.
- Careful consideration should be given to instrumentation to maintain safety even when a trouble like disconnection of power/signal cable or unexpected malfunction or failure occurs.

Using a stable power supply

The external output and alarm contact of the gas detector may be activated when the power is turned on, when momentary blackout occurs, or when the system is being stabilized. In such cases, use a UPS (uninterruptible power system), or take appropriate actions on the receiving side.

The gas detector must be provided with the following power supply.

Power supply voltage	100 - 240 VAC (terminal voltage of the gas detector) 50/60 Hz Supply voltage fluctuations up to $\pm 10\%$	
Allowed time of momentary blackout	Up to 500 milliseconds (To recover from the momentary blackout for 500 milliseconds or more, restart the gas detector.)	<u>Example of actions</u> To ensure continuous operation and activation, install a UPS (uninterruptible power system), etc. outside the gas detector.
Others	Do not use it with a power supply of large power load or high-frequency noise.	<u>Example of actions</u> Use a line filter, etc. to avoid the noise source if necessary.

Heat radiation designing

When it is installed in the closed instrumentation panel, attach ventilation fans above and below the panel.



CAUTION

When the internal temperature of the gas detector reaches about 60°C, the power will be turned off. Since the internal temperature rises to ten-odd degrees higher than the ambient temperature, take care not to let the ambient temperature exceed 30°C. Provide a clearance of 30 mm or more above the gas detector to prevent a rise in the internal temperature.

Introducing protective measures against lightning

If cables are installed outside the factory/plant, or if internal cables are installed in the same duct as the cables coming from outside the factory/plant, "lightning" will cause problems. Because lightning acts as a large emission source while cables act as a receiving antenna, devices connected to the cables may be damaged.

Lightning cannot be prevented. Cables installed in a metal conduit or under the ground cannot be completely protected from inductive lightning surge caused by lightning. Although complete elimination of disasters caused by lightning is impossible, the following protective measures can be taken.

Protection against lightning	<u>Take appropriate measures in accordance with the importance of the facilities and the environment.</u> <ul style="list-style-type: none"> • Connect the transmission signal route by using optical fiber. • Provide protection by a lightning arrester (cable arrester). (Although inductive lightning surge can be transmitted through the cable, it is prevented by installing a lightning arrester before the field devices and central processing equipment. For information on how to use a lightning arrester, please contact the manufacturer.)
Grounding	In addition to lightning, there are more sources of surge noise. To protect units from these noise sources, the units must be grounded.

- * The lightning arrester has a circuit to remove a surge voltage which damages field devices, so that signals may be attenuated by installing the arrester. Before installing a lightning arrester, verify that it works properly.

Proper use of alarm contact

The alarm contact of the gas detector is used to transmit signals to activate the alarm lamp, rotating lamp, etc. Do not use it for controlling purpose (e.g. controlling the shutdown valve).



CAUTION

The "b" contact (break contact) under de-energized state may be opened momentarily by a physical shock, such as external force.

When the "b" contact is selected for the alarm contact, take appropriate actions to prepare for a momentary activation, for example, add signal delay operation (approximately one second) to the receiving side of the "b" contact.

The specifications for the alarm contact of the gas detector are based on the resistance load conditions. If inductive load is used at the alarm contact, the following errors will occur easily because counter electromotive force is generated at the contact.

- Deposition, defective insulation or defective contact at the relay contact
- Damage of any electric parts due to high-voltage generated inside the gas detector.
- Abnormal operations by an out-of-control CPU



CAUTION

- In principle, do not activate inductive load at the alarm contact of the gas detector. (In particular, never use the inductive load to activate a fluorescent lamp, motor, etc.)
- If inductive load is activated, relay it with an external relay (contact amplification). However, because the coil of an external relay also involves inductive load, select a relay at a lower voltage (100 VAC or below), and then protect the contact of the gas detector with an appropriate surge absorbing part, such as a CR circuit.

If load is to be activated, appropriate measures must be taken to stabilize the operation of the gas detector and protect the alarm contact referring to the following information.

- Relay it with an external relay at a lower voltage of 100 VAC or below (contact amplification). At the same time, the surge absorbing part SK1 suitable for the specifications must be attached to the external relay.
- In addition, the surge absorbing part SK2 must be attached to the loaded side of the external relay if necessary.
- It may be recommended that the surge absorbing part should be attached to the contact for certain load conditions. It must be attached to an appropriate position by checking how the load is activated.

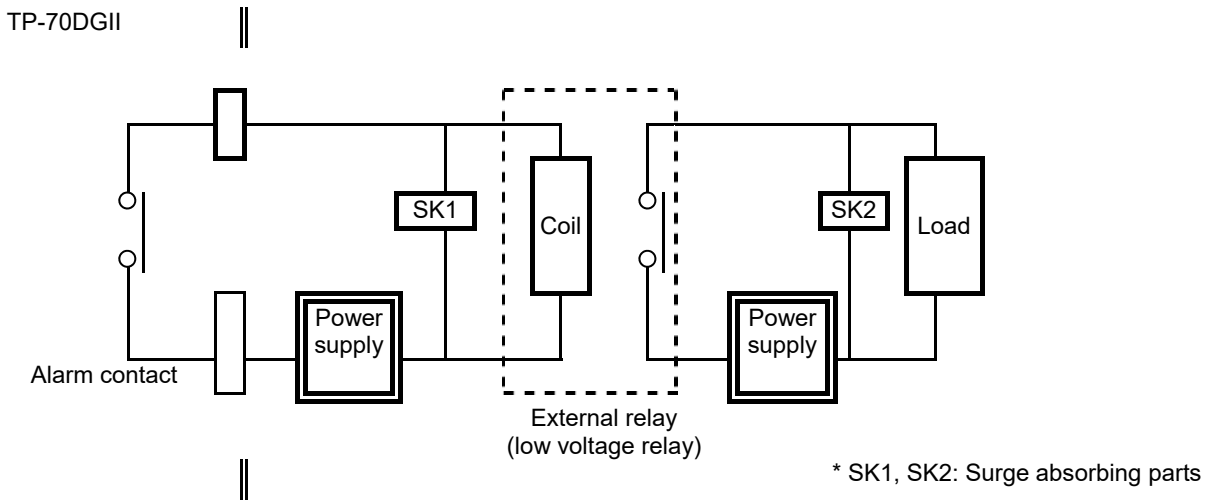

4-4. How to wire



CAUTION

- Be careful not to damage the internal electronic circuit when wiring. In addition, be careful not to apply stresses on the gas detector when (overweight) cables are installed.
- The power cables and signal cables must not be installed together with the motor power cables, etc. When these cables must be installed together for unavoidable reasons, put the power cables and signal cables in a metal conduit. The conduit must be connected to a grounding circuit.

<Recommended Cables>

4 - 20 mA transmission	Shielded cable of CVVS, etc. (1.25 sq) - 2-core
Contact output	Cable of CVV, etc. (1.25sq) - max. 6-core
2-wire type DC power-line communication system	Shielded twisted-pair cable of KPEV-S, etc. (1.25 sq) - 1P
LAN (for Ethernet and PoE)	Ethernet cable (category 5 or higher) UTP (unshielded twisted-pair cable) Supported medium type: 100BASE-T or higher Cable specification: Single wire (5 m maximum for a stranded wire) Modular plug: RJ-45 Number of cores: 8-core Wire connection: Straight

<Figure of Terminal Plate>

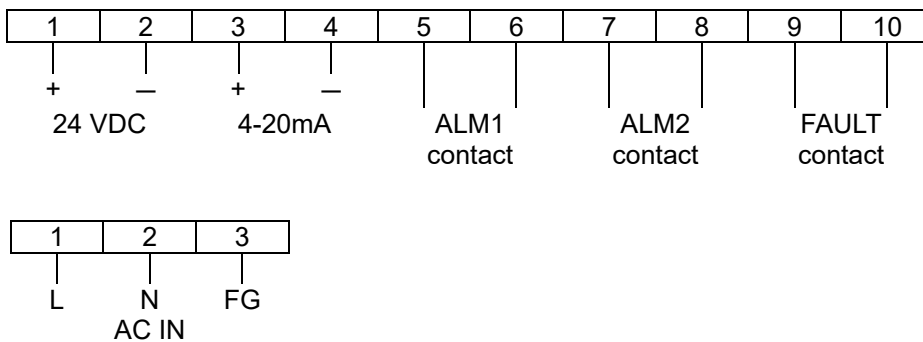

NOTE

- The 24 VDC terminals 1 and 2 are unavailable for the Ethernet and PoE specifications. (Connection prohibited)
- The 4 - 20 mA terminals 3 and 4 are unavailable for the 2-wire type DC power-line communication system (NT) specification. (Connection prohibited)



WARNING

To operate the gas detector on 200 VAC system, prepare a power cable that supports 200 VAC. The power cable is provided only for the case that the power voltage is 100 VAC system (requested). The provided power cable supports 100 VAC.

<Specifications of Terminal Plate>

Specifications of terminal plate

- Rated voltage: 250 VAC
- Rated current: 20 A
- Terminal size: M4



CAUTION

The terminal plate specifications given on the left does not mean the connectable load capacity.

<Grounding>

Connect the gas detector to your grounding terminal.



WARNING

Before turning on the gas detector, never fail to connect it to a grounding terminal. For stable operation of the gas detector and safety, it must be connected to a grounding terminal. Do not connect the grounding wire to a gas pipe. The grounding must be made as D type grounding (below 100 Ω of grounding resistance).

<How to Use Communication Connectors>

To use Ethernet or PoE connection, insert a LAN cable to the communication connector (RJ45) at the back of the main unit.

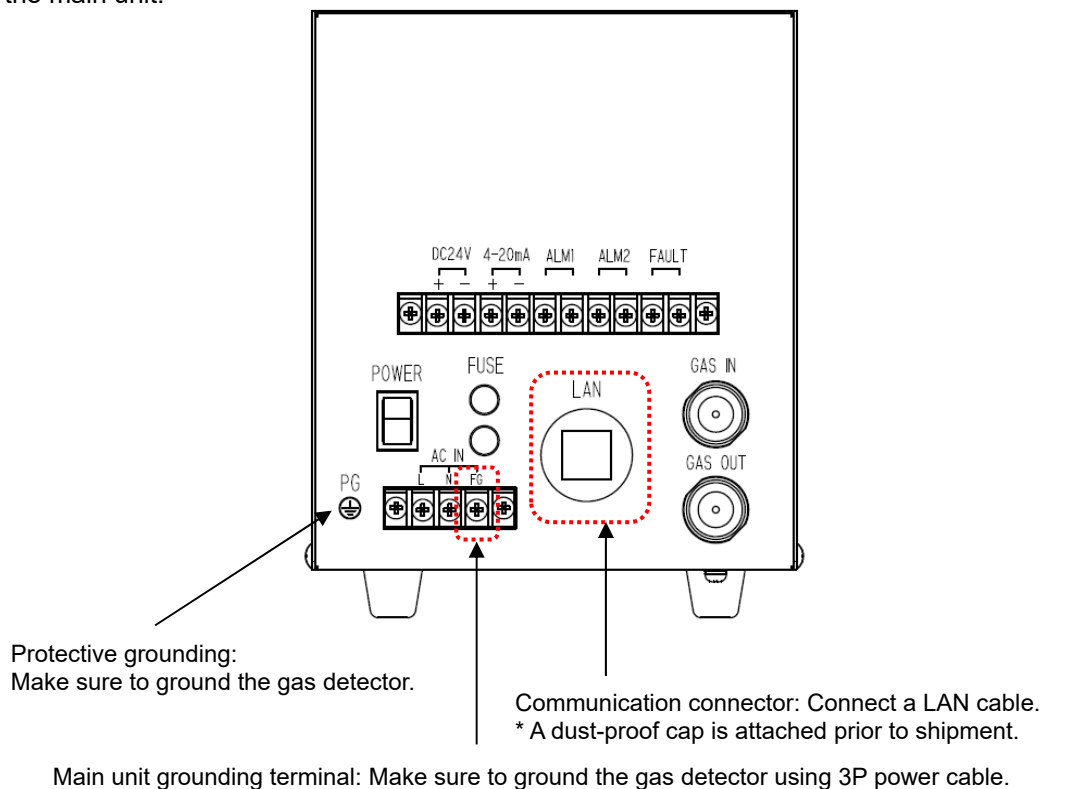

<Wiring Example>

Connecting to the upper unit (DCS, PLC) (EA specification, 2-wire type/4 - 20 mA)

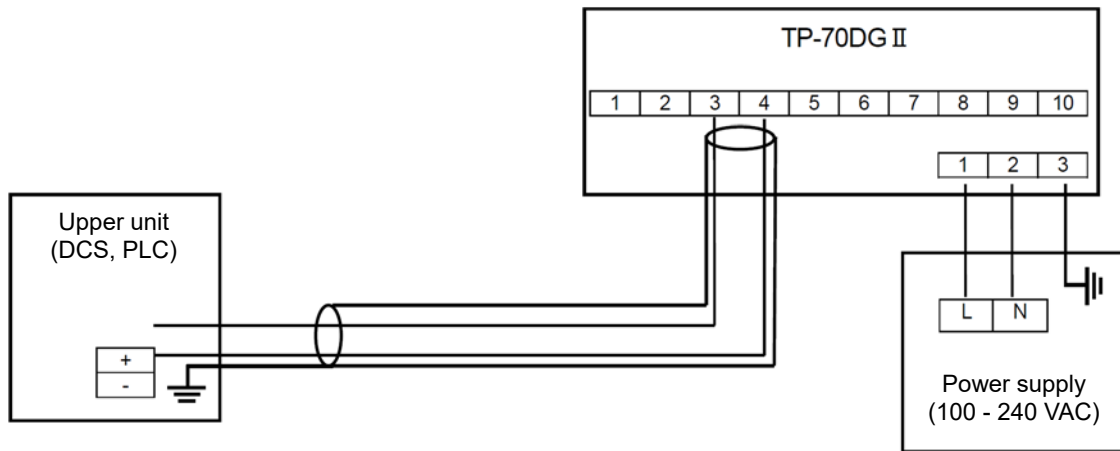

Connecting to the upper unit (PC, PLC) (EA specification with Ethernet)

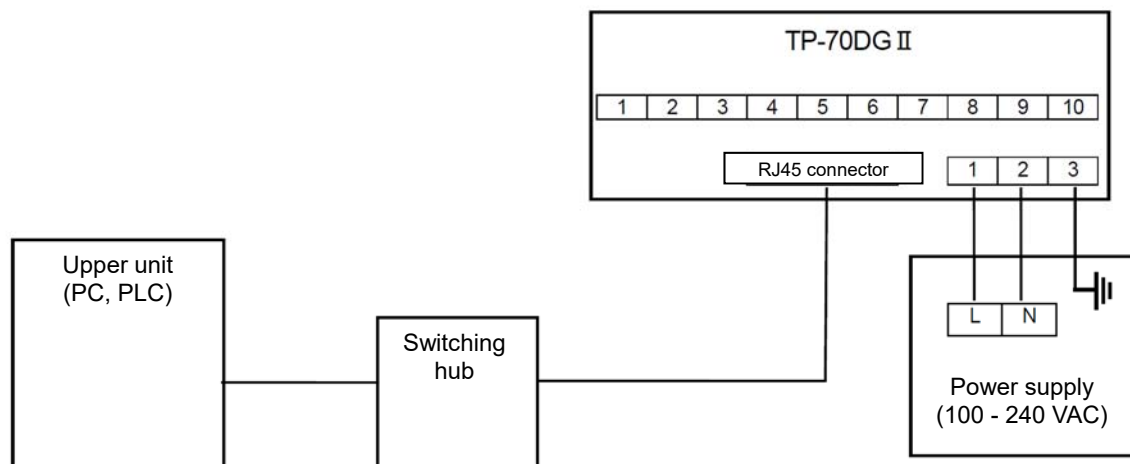

CAUTION

Do not use a switching hub equipped with PoE function with the Ethernet specification. Using it causes the PoE power and 24 V power to be supplied at the same time, which may result in a failure.

Connecting to the upper unit (PC, PLC) (EA specification with PoE)

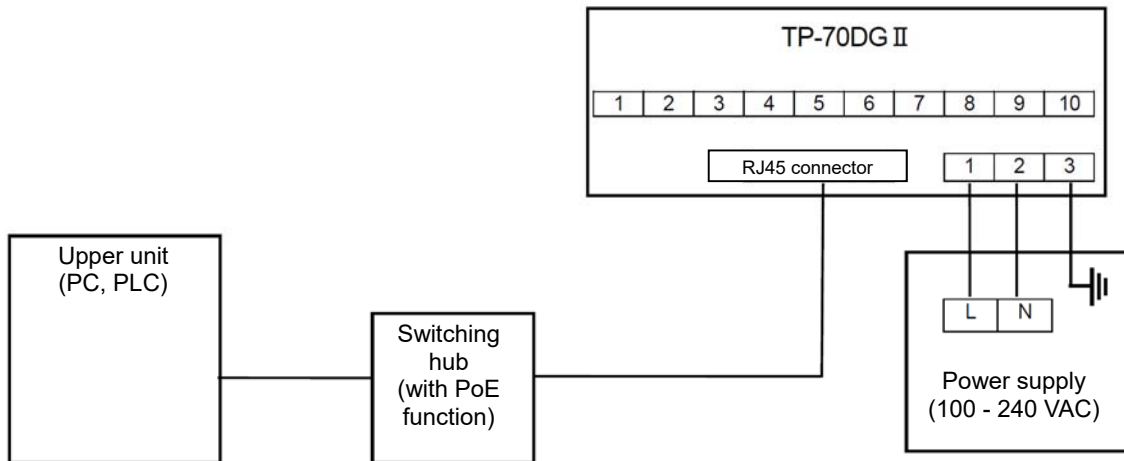

CAUTION

Be sure to use a switching hub equipped with PoE function with the PoE specification. If the PoE function is unavailable, the power will not be supplied to the display unit.

Connecting to the multi-display unit (RM-70NT) (NT specification)

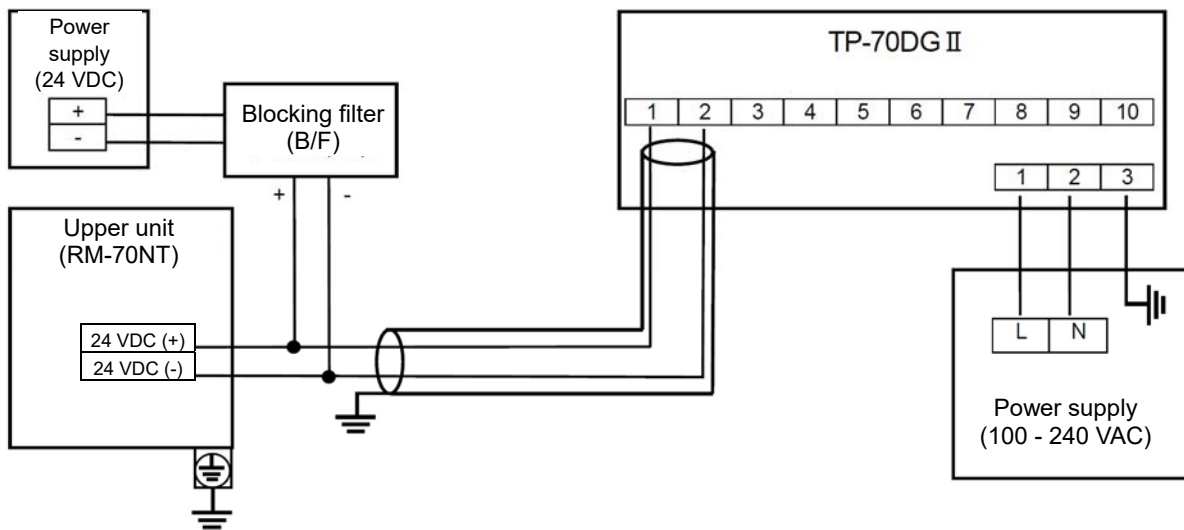

4-5. How to Tube

The gas detector has a Rc1/4 thread inside the sampling inlet/outlet (GAS IN, GAS OUT), to which “polypropylene” unions are normally attached. Because their material varies depending on the gas to be used, please specify the gas.

The compatible tube is a Teflon tube of $\Phi 6$ (OD) - $\Phi 4$ (ID). The tube must be installed with the supplied ferrules and sleeves attached to prevent a leak.

When the tube is cut, its cut point has a smaller inner diameter. Use a file etc. to expand the inner diameter of the cut point. To remove cut-dust or other materials remaining inside of the tube, never fail to blow compressed air into the tube before connecting it to the gas detector.

Some sample gases have highly adsorptive or corrosive property. Select the tube material taking into account of these precautions.

The flow rate of the gas detector itself is approximately 0.5 L/min under the operating temperatures. When a gas is drawn from a distant point, please consult us on the tube length.

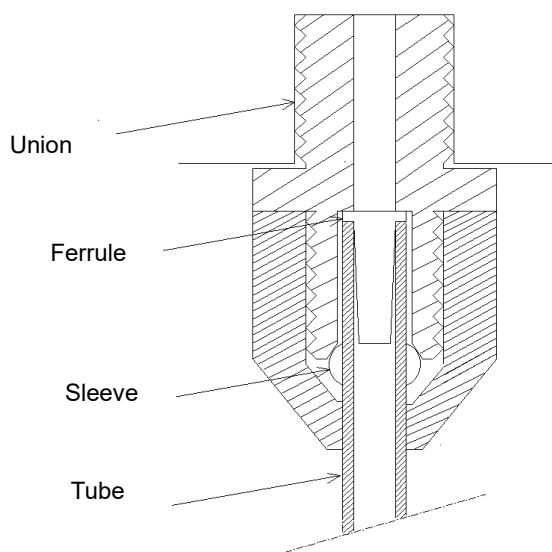

WARNING

- The gas detector is designed to draw gases under the atmospheric pressure. If excessive pressure is applied to the sampling inlet and outlet (GAS IN, GAS OUT) of the gas detector, detected gases may be leaked from its inside, thus leading to dangers. Be sure that excessive pressure is not applied to the gas detector while used.
- Detected gases must be exhausted from the detected gas exhausting outlet (GAS OUT) on the back of the gas detector to which an exhaust tube is connected, to a point regarded as a safe place.



CAUTION

- The longer the GAS IN tube is, the longer it takes for a gas to reach the gas detector. Because some gases have a highly adsorptive property for the tube, resulting in a slow response and a lower reading than the actual value, the length of the GAS IN tube must be minimized.
- When the humidity in the sampling point is high, condensation may be formed inside of the tube. Make sure to avoid condensation when using a gas which is dissolved into water and corrodes contacted materials, such as a strong acid gas, because it may disable the gas detector for detecting gas and furthermore may corrode internal parts. Also avoid an excessive U-shaped or V-shaped tube piping.
- Determine the inlet for the sample gas, considering the airflow of the sample gas line and the gas generating process.
- Never fail to attach the supplied filter in the middle of the tube.
- It is needed to decide the length and material of the tube. Please contact RIKEN KEIKI for more information.

5

How to Operate

5-1. Preparation for start-up

Before connecting a power supply, read and understand the following precautions. Ignoring these precautions may cause an electric shock or damage the unit.

- Connect the gas detector to a grounding circuit.
- Check that the external wiring is done properly.
- Check that the power voltage is compliant with the specification.
- Because the external contact may be activated during the adjustment, take measures to prevent an activated contact from having influences on external circuits.
- Remove the protective rubber cap from GAS IN and GAS OUT. If the gas detector is turned on with the rubber caps remaining while the installation, applied overload may damage the pump and sensor. Never fail to remove the caps.
- Check that there is no clogging or leak in the connected tube. (If the connected tube is clogged, pressure is applied to the sensor unit, causing errors and malfunctions.)
- Check that the filter is attached properly. (The filter is specified based on the gas to be detected.)
- Make sure to use a fuse with the specified ratings to prevent fire.
- Check that the gas detector is leveled. The gas detector must be installed in the right direction to ensure its performance. (* The direction of the gas detector must also be kept during transportation, including when it is removed temporarily or relocated.)

5-2. Basic operating procedures

Normally, the detection mode is used for normal operations. (The detection mode is activated after the power is turned on.)

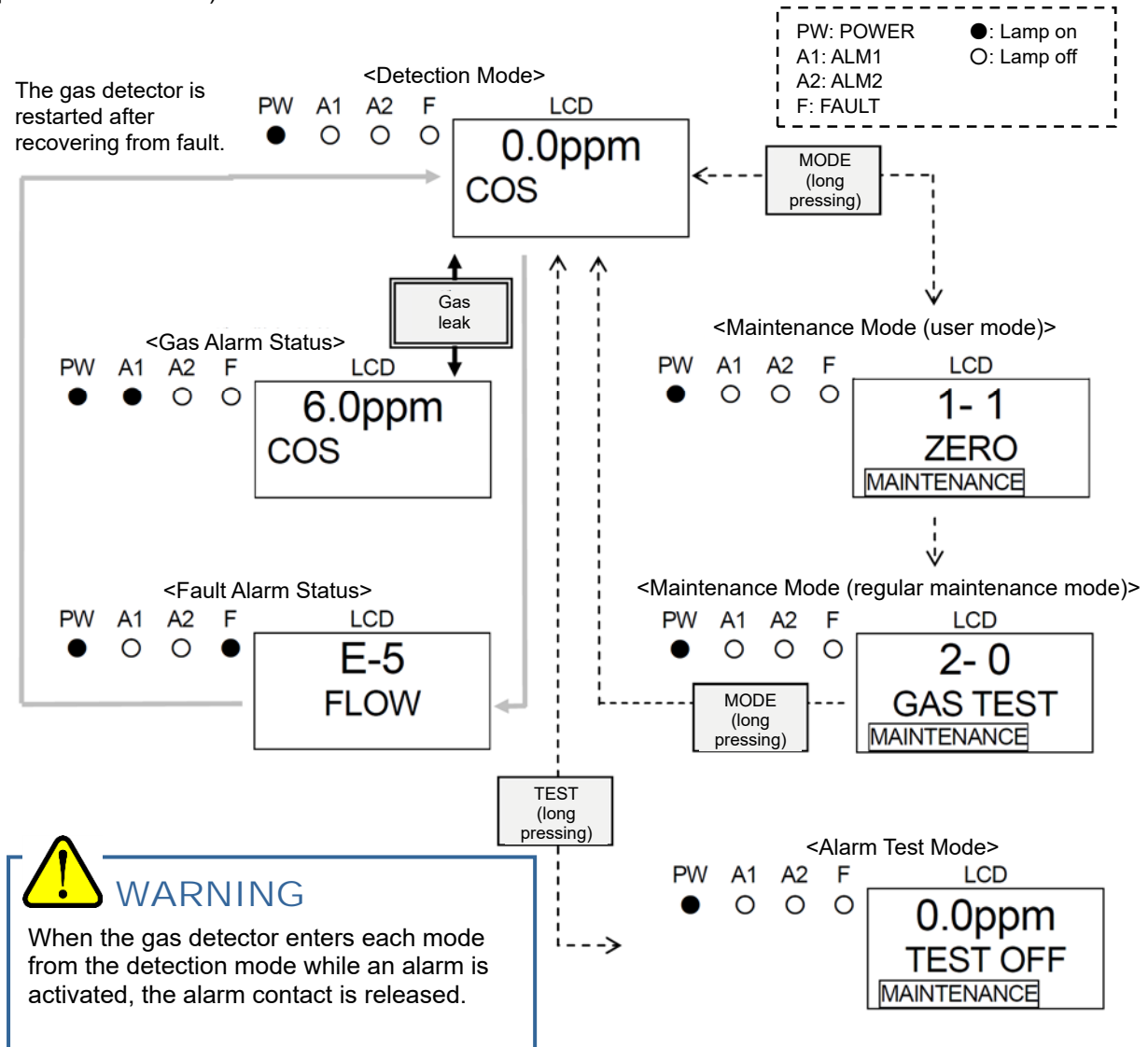

5-3. How to activate the gas detector

- Before turning on the power switch, check that the gas detector is installed properly.
- Turn on the power switch located on the rear side of the main unit.
- The gas detector contains a catalyst and requires warm-up to deliver adequate performance. Warm up the gas detector for a specified period to obtain accurate detection of gases. (After the power switch is turned on, the gas detector enters the detection mode immediately after the start-up flow.)

<Warm-up Time>

- Unpowered time lasts one week or more
 => Warm up the gas detector for 24 hours or more.
 Note that the warm-up time can be reduced using the regular maintenance mode "2-13. PL AGING".
 * See "7-2. Regular maintenance mode".
- Unpowered time lasts less than one week
 => Warm up the gas detector for two hours or more.

<PoE Specification>

- For the PoE specification, the power is supplied via a LAN cable, and the power switch of the display unit needs to be operated.
- The power switch of the display unit is protected by a cover to prevent access to it in a normal time. To turn ON/OFF the power switch, rotate the switch cover. (Return the switch cover to the original position after the switching is completed.)

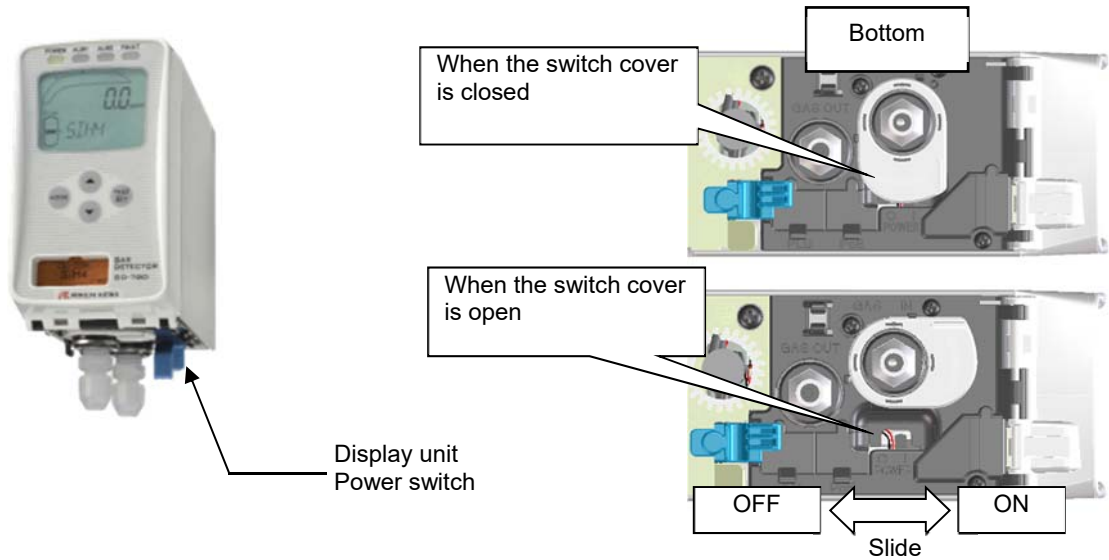

- For the PoE specification, turn on the power switch of the main unit first, and then turn on the power switch of the display unit.
- After the gas detector completes the start-up, it enters the detection mode swiftly. Warm up the gas detector for a specified period to obtain accurate detection of gases.

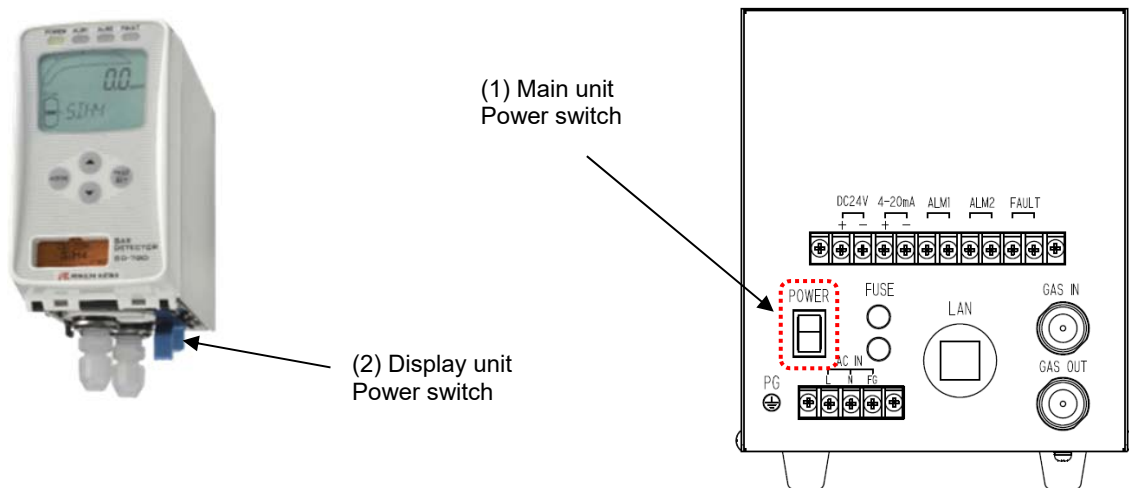

CAUTION

- For the PoE specification, turn on the power switch of the main unit first, and then turn on the power switch of the display unit. If the power switch of the display unit is turned on first, the pyrolyzer may malfunction and an error "E-7 PL UNIT" may occur. If the error is displayed, turn on the power again in the correct order.

<Start-up Procedures (approximately 25 seconds for system check of the gas detector and alarm deactivation)>

Power On



Initial clear

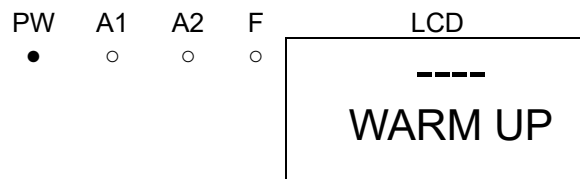

Gas Specifications Display

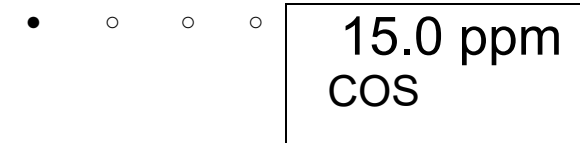

Detection mode

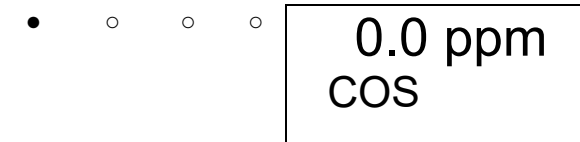

CAUTION

- Do not turn off the gas detector during the initial clear. The gas detector is reading the sensor memory during the initial clear.
- When the power is turned off to perform replacement or maintenance of parts, the gas detector needs to be warmed up for a specified period which is determined depending on the length of unpowered time.
- During the warm-up, the alarm activation and output signals are unstable. Provide a prior notification to the related sections so that they can prepare for false abnormalities.
- After the warm-up is completed, check that the reading on the flow rate indicator corresponds to the specified flow rate, and then perform a calibration.

5-4. Modes

Details on each mode are provided as follows. (* Operations are slightly different depending on the sensor unit.)

Mode	Item	LCD display	Details
Detection mode	—	Gas concentration Gas name	Normal state
Alarm test mode	—	Gas concentration	Perform the alarm test.
Maintenance Mode (User)	Zero Adjustment (span adjustment)	1-1 ZERO (1-1 SPAN)	Perform zero adjustment. (In case of oxygen 0 - 25 vol%, perform span adjustment.) => <u>Span adjustment is not used on the gas detector.</u>
	Setting Display	1-2 CONFIRM	Display the typical settings. <ul style="list-style-type: none"> • First alarm setpoint (AL1) • Second alarm setpoint (AL2) • Alarm delay time • Zero suppression value • Zero follower ON/OFF • Sensitivity correction ON/OFF
	Flow Rate Indicator	1-3 FLOW	Display the current flow rate.
	Address Display	1-4 ADDRESS	Display the address.
	Main Unit Version Display	1-5 70D VER	Display the program version of the main unit.
	Unit Version Display	1-6 UNIT VER	Display the program version of the sensor unit.
	Net Version Display	1-7 NET VER	Display the program version of the communication function.
	Communication output setting	1-8 COM SET	Set communication output.
	Regular maintenance mode switching	1-9 M MODE	Switch to the regular maintenance mode.
	Maintenance mode (Regular maintenance)	See "7-2. Regular maintenance mode".	

5-5. Detection mode

<Flow Rate Indicator>

Because the flow rate of the gas detector is automatically adjusted by the flow rate control function, the flow rate, in principal, does not need to be controlled. As shown on the figure below, when the flow rate does not correspond to the specified flow rate for some reasons, it is adjusted automatically.

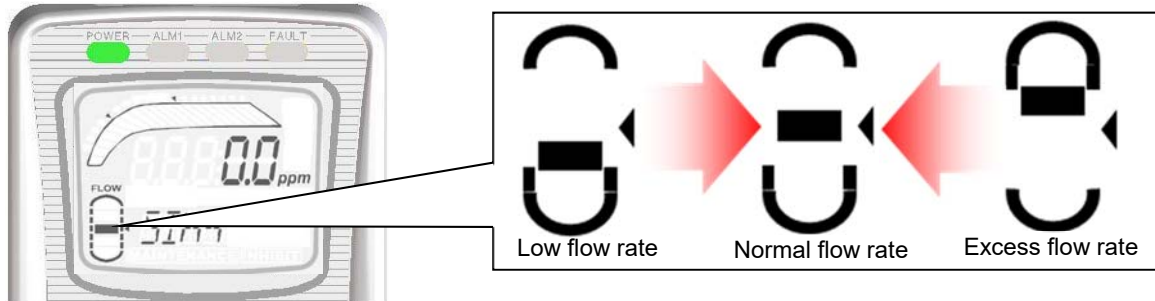

CAUTION

If the automatic flow rate adjustment does not work (due to clogged tube or leak), messages such as "FLOW" for an unstable flow rate or "E-05" for flow rate abnormalities are displayed. In this case, you must identify the causes and take appropriate actions.

5-6. Alarm test mode

This is used when dummy signals the same as the signals of the gas concentration are generated to check the alarm lamp activation of the gas detector and the transmission to external circuits.



WARNING

Before starting the alarm test (transmission test), provide a notification to the related sections so that they can prepare for false abnormalities (external output signals and alarm contact). After the test is completed, never fail to press the TEST key to return to the detection mode.
(If the gas detector remains in the alarm test mode, it automatically returns to the detection mode in ten hours.)

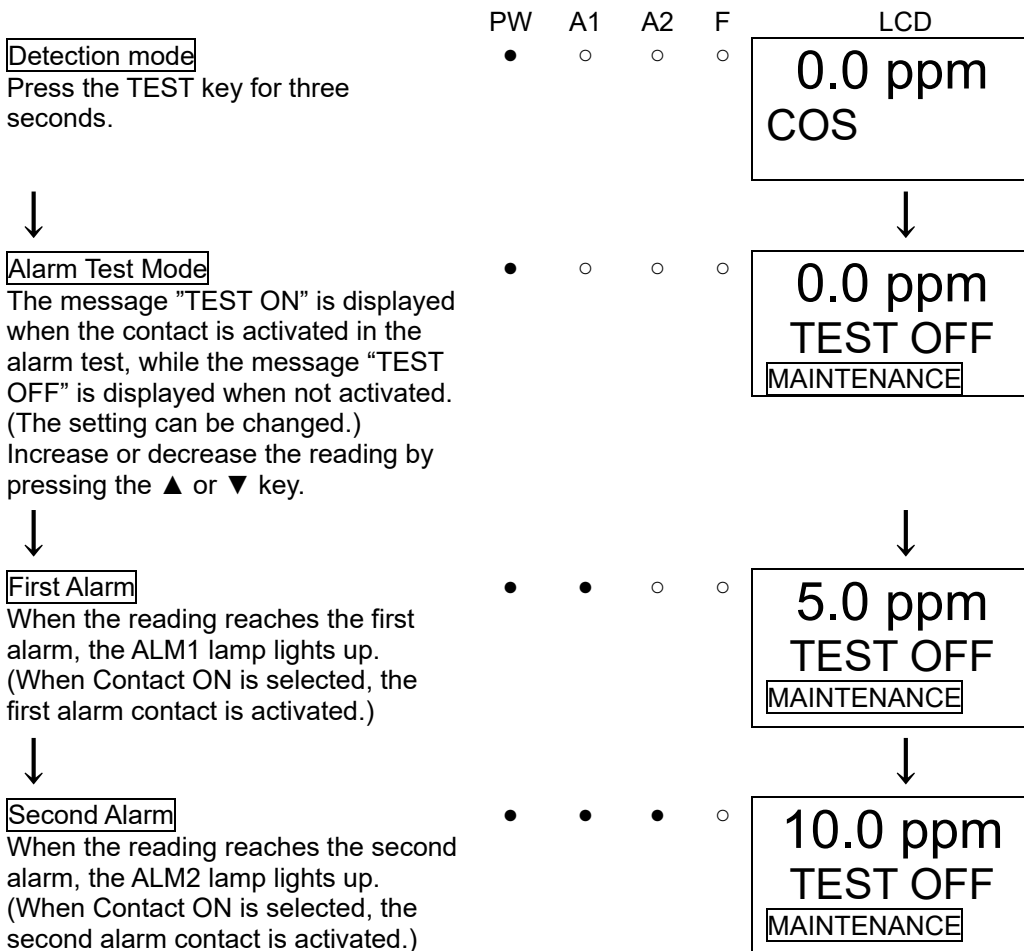

5-7. User mode



WARNING

After the adjustment is completed, never fail to press the MODE key to return to the detection mode.
(If the gas detector remains in the user mode, it automatically returns to the detection mode in ten hours.)

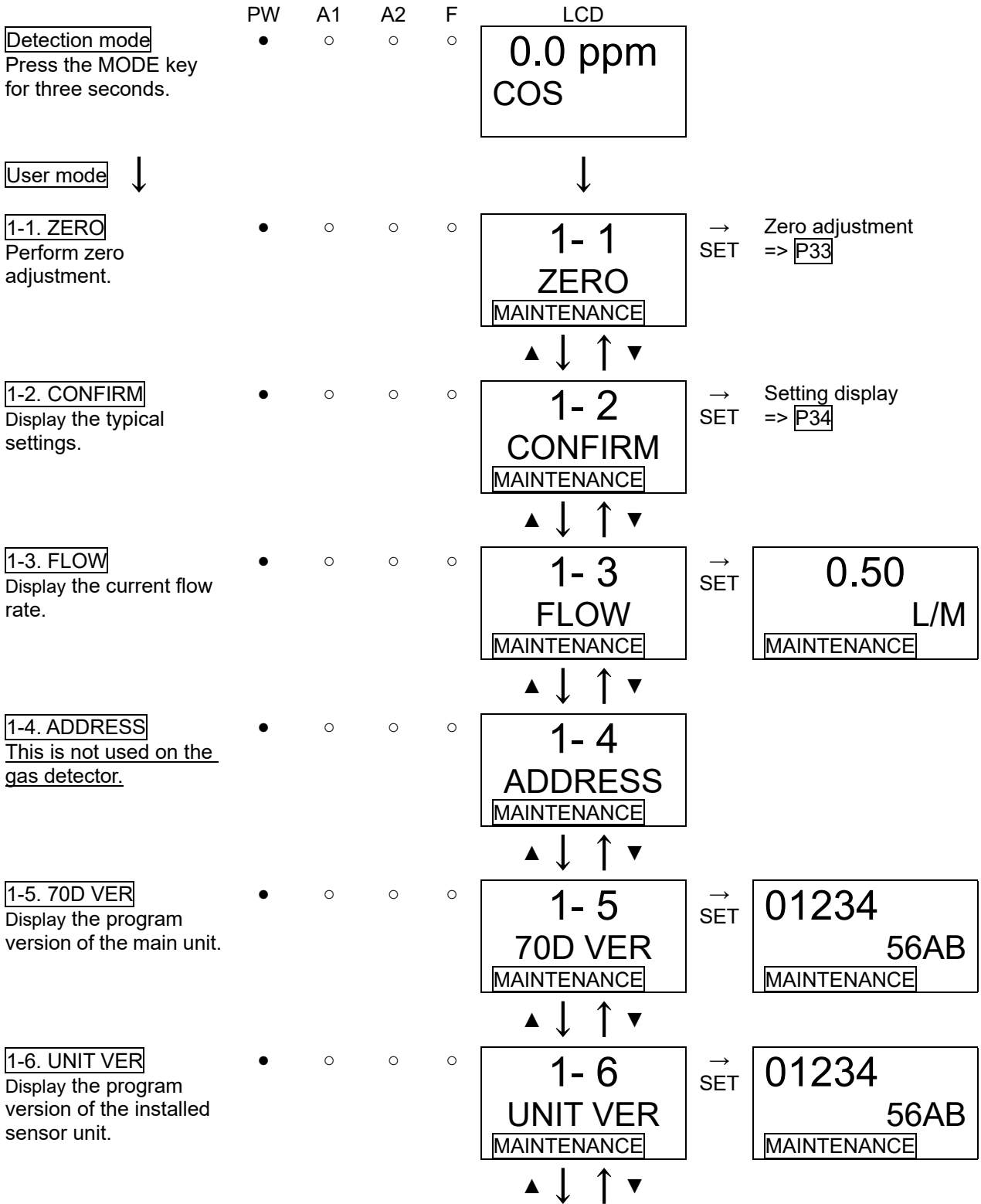

1-7. NET VER

Display the program version of the communication function.

- ○ ○ ○ ○

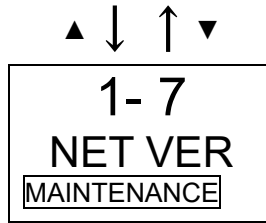

→ SET

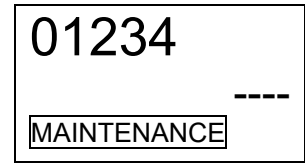

1-8.COM SET

Set communication output.

- ○ ○ ○ ○

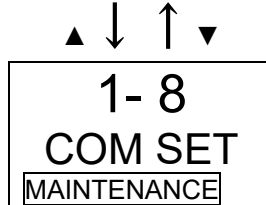

⇔ SET



Press the ▲ or ▼ key to select the communication output, and then press the SET key to confirm the value.

A: Analog transmission
 E: Ethernet
 EA: Ethernet and analog transmission



▲ ↓ ↑ ▼
 To **1-1. ZERO**



1-9. M MODE

Switch to the regular maintenance mode.

- ○ ○ ○ ○

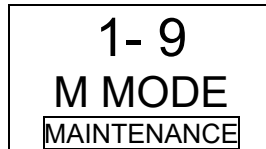

→ SET

See "7-2. Regular maintenance mode".

NOTE

- For the case of using analog transmission only (Ethernet is not used), when the communication output is set to A, Communication Abnormalities **E-6** does not occur even if an Ethernet cable is not connected.

<Zero Adjustment "1-1">

This is used to perform the zero adjustment. Before starting the zero adjustment, let the gas detector draw the zero adjustment gas and wait until the reading is stabilized.

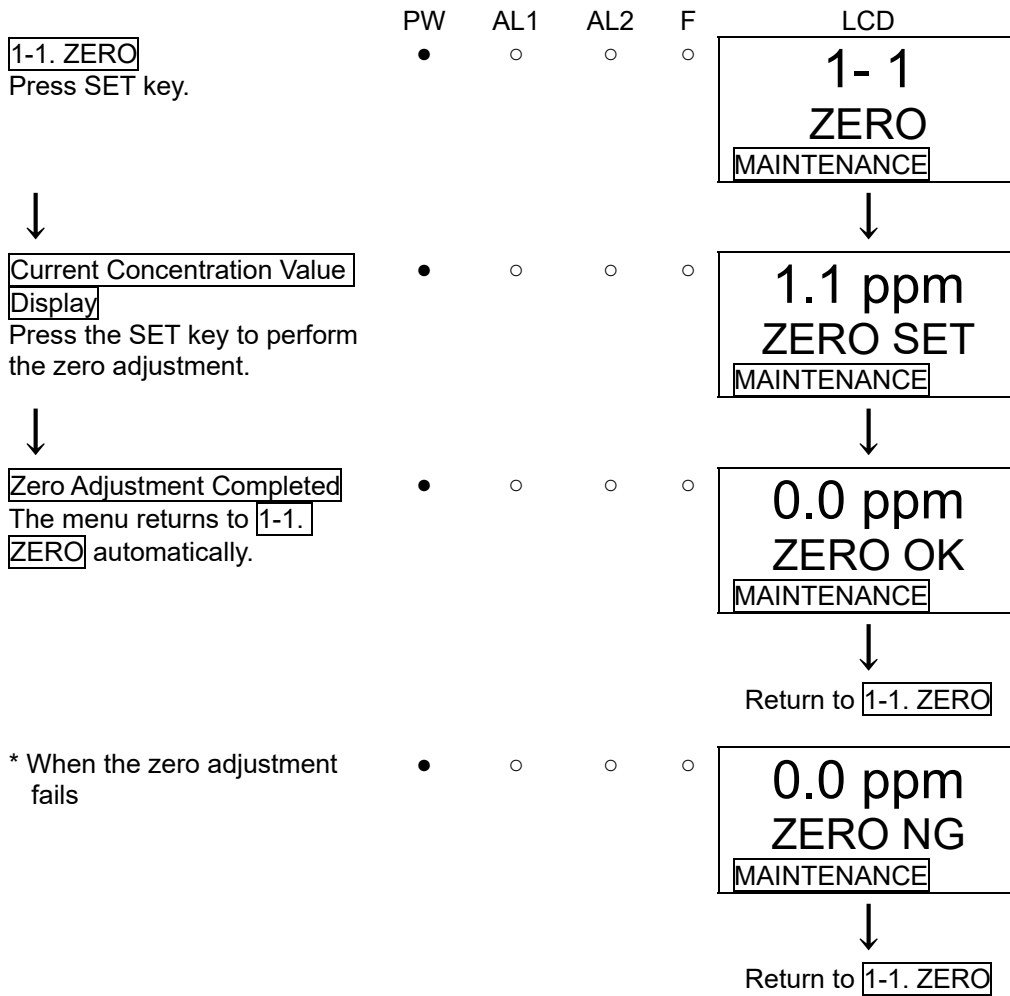

<Setting Display "1-2">

This is used to check the setting of typical menus.

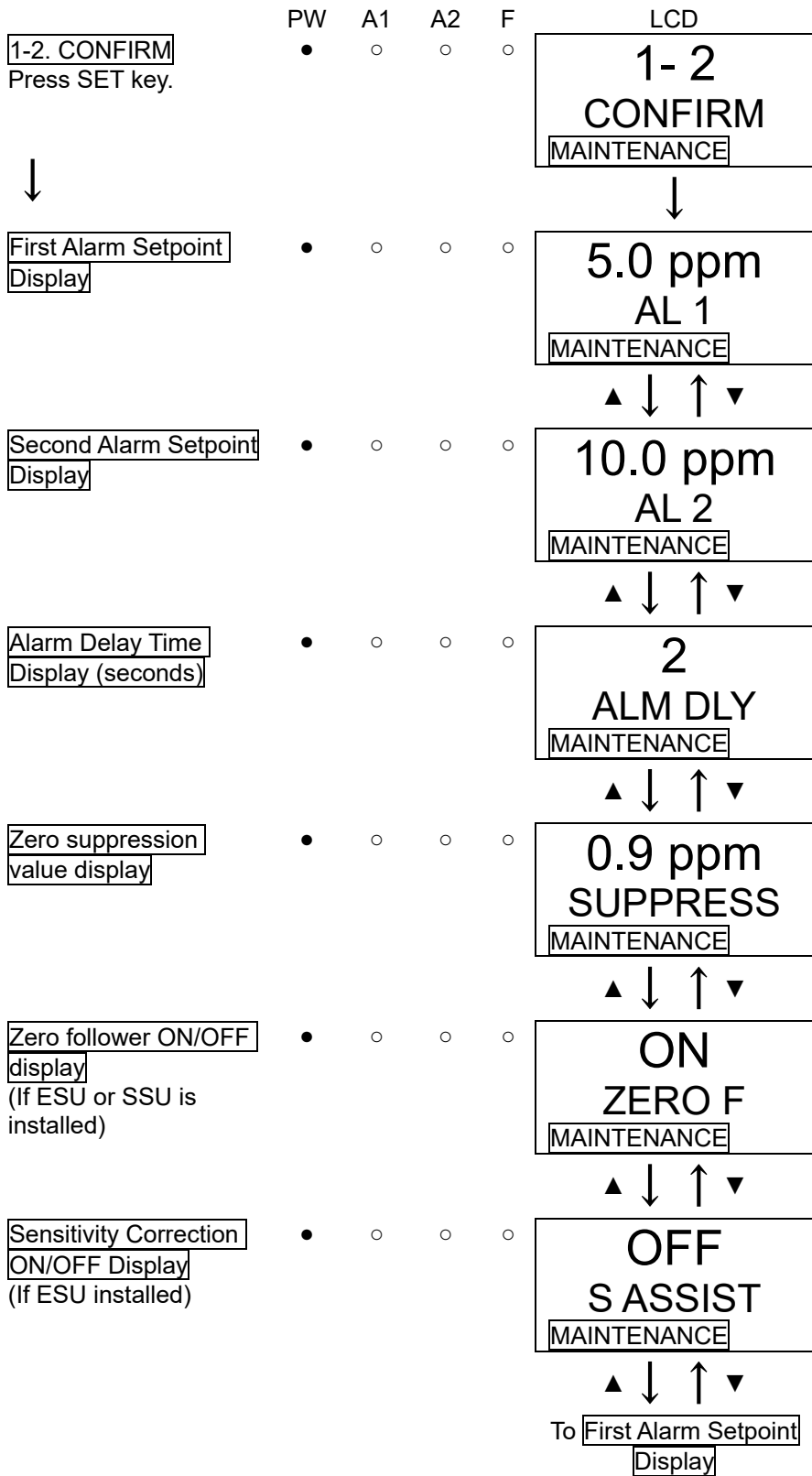

5-8. How to exit

To turn off the gas detector, turn "OFF" the power switch located on the rear side of the main unit. Then, turn off the power supply to the gas detector.



WARNING

- When the gas detector is turned off, an alarm may be triggered on the upper (central) system. Before turning off the gas detector, the inhibit (point skip) on the upper (central) system must be activated. Decide whether the power can be turned off by checking the operation of the devices connected to the external output or external contact output terminal of the gas detector.
- If the alarm contact is energized (option), it is activated when the gas detector is turned "OFF".
- If the gas to be detected has an adsorptive property, the gas detector must be cleaned thoroughly with fresh air before turning "OFF" the gas detector.

6

Operations and Functions

6-1. Gas alarm activation

Gas alarm: Triggered when the concentration of detected gas reaches or exceeds the alarm setpoint value.
<Auto-Reset Operation>

NOTE

The alarm setpoint (first alarm and second alarm) is factory-set. Although the alarm delay time (standard: two seconds) works in the gas detector to prevent a false activation, it can be canceled if not needed.

<Display Operation>

Gas Concentration Display

In case of over the detection range (Over Scale), "∞ ∞ ∞ ∞" is displayed on the LCD.

Power Indicator Lamp (POWER: Green)

This lights up continuously.

Alarm Indicator Lamp (ALM1: Red), (ALM2: Red)

The alarm consists of two steps. Each of them lights up when the respective alarm setpoint value is reached to or exceeded.

<Contact Activation>

The contact is activated when the gas concentration reaches or exceeds the alarm setpoint value. The contact activation is reset automatically when the gas concentration drops below the alarm setpoint value.

"Alarm Pattern (H-HH)"

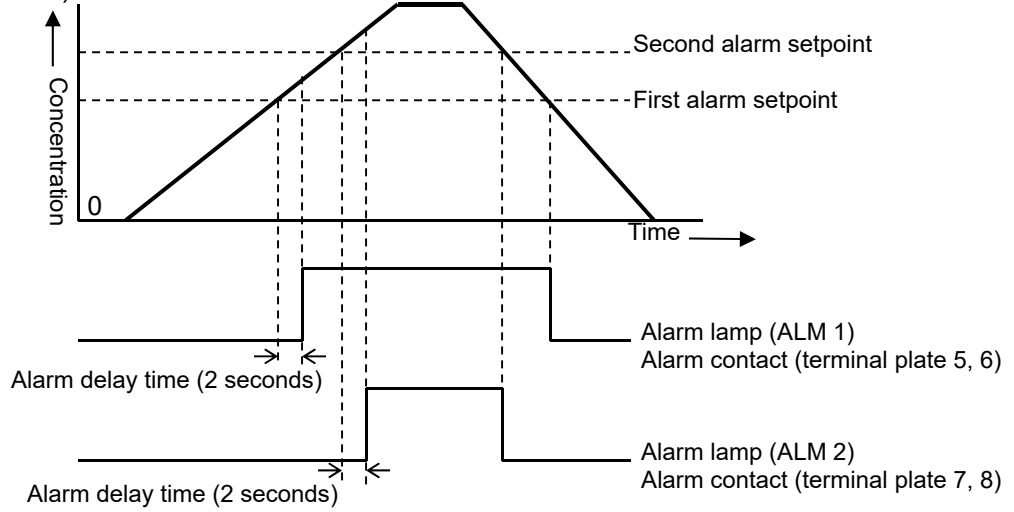

"Alarm Pattern (L-LL)"
(* oxygen deficiency alarm)

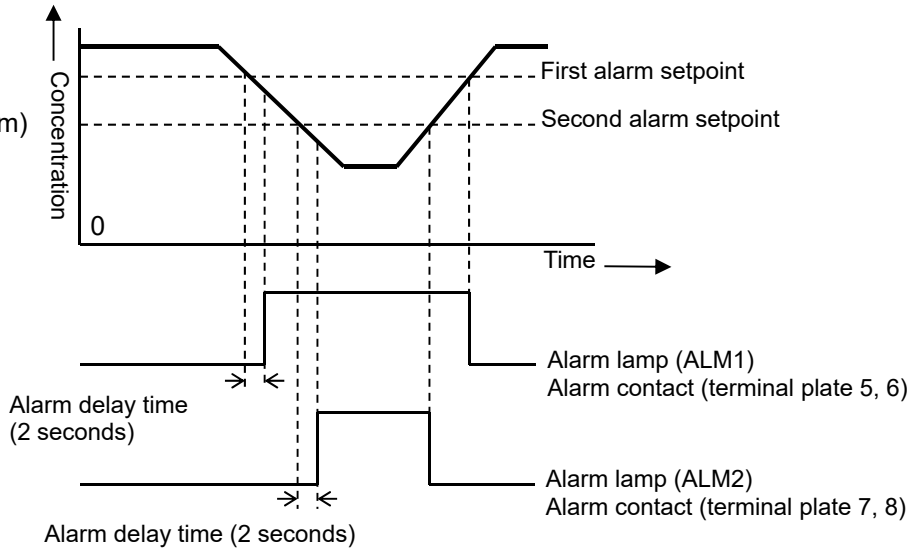

<Response to Gas Alarm>**In case of responding to a leaked gas**

When a gas alarm is triggered, take actions in accordance with your management rules of gas alarm. Normally, take the following actions.

- Check the reading of the gas detector.

NOTE

If a gas leak is momentary, the reading may already have dropped when checking it. In addition, when the alarm is triggered by noise or other incidental conditions other than a gas, the reading may have already dropped.

- Based on your management rules of gas alarm, no one can be allowed to access the monitored zone to ensure safety.
- If the Gas Concentration Display continues to be shown, close the main valve of the gas, and then check that the gas concentration reading is dropped.
- Assuming that gases remain, wear protective equipment to avoid dangers and go to the gas leak point, and then check if gases remain using a portable gas detector etc.
- If you can determine that the point is free from dangers, take actions to fix the gas leak.

6-2. Fault alarm activation

A fault alarm is triggered when the gas detector detects abnormalities. After a fault alarm is triggered, the FAULT lamp (yellow) lights up and an error message is displayed on the LCD. Determine the causes and take appropriate actions.

After the gas detector is successfully returned from the fault, it restarts with the process normally performed right after it is turned on (initial clear).

If the gas detector has problems and is repeatedly malfunctioning, contact RIKEN KEIKI immediately.



* E-5 FLOW
(flow rate abnormalities)

NOTE

For information on malfunctions (error messages), see "9. Troubleshooting".

6-3. External output operation

Specifications	4 - 20 mA	Power-line communication system	Ethernet
Signal Transmission System	Analog transmission (non-isolated)	2-wire type DC power-line communication	Ethernet (10BASE-T/100BASE-TX)
Transmission Path	CVVS	KPEV-S	Ethernet cable
Transmission distance	Below 1 km	Below 300m (depending on the system conditions)	Below 100m (depending on the system conditions)
Connection Load Resistance	Below 300 Ω	—	
(1) Detection mode (no alarm)	4 - 20 mA (concentration output)	Concentration data	
(2) Detection mode (gas alarm)	4 - 20 mA (concentration output)	Concentration data, Alarm bits	
(3) Initial Clear	Depending on the setting of (4) 2.5 mA setting: 2.5 mA 4 mA, HOLD, 4 - 20 mA setting: 4 mA*	Initial bit	
(4) Maintenance Mode	2.5 mA setting: 2.5 mA 4 mA setting: 4 mA* HOLD setting: The previous value retained 4-20 mA setting: 4 - 20 mA (concentration output)	Concentration data, Adjustment bit	
(5) Alarm Test	Output ON setting: 4 - 20 mA (concentration output) Output OFF setting: The previous value retained	Concentration data, Adjustment bit, Test bit	
(6) Fault Alarm	0.5 mA (Fixed)	Fault bits	
(7) Inhibit	Depending on the setting of (4) 2.5 mA setting: 2.5 mA 4 mA, HOLD, 4 - 20 mA setting: 4 mA*	Concentration data, Adjustment bit, Inhibit bit	
(8) Power interruption	0mA	Signal OFF	

* OSU - 0 - 25 vol% is equivalent of AIR (20.9 vol% = 17.4 mA)

Example of Gas Concentration and External Output

4 - 20 mA
(Maintenance output:
2.5 mA setting)

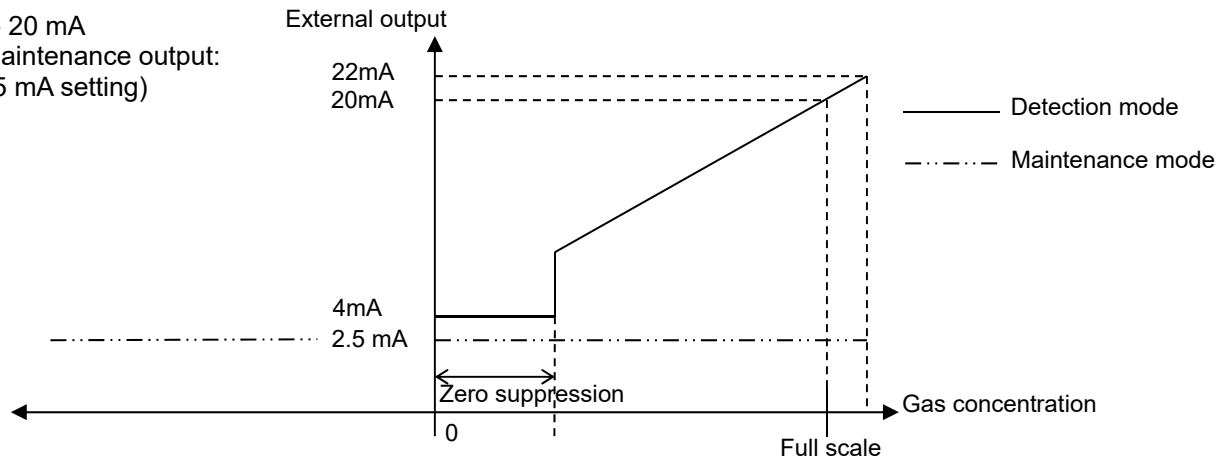
**CAUTION**

<Analog Transmission (4 - 20 mA)>

- The 4 - 20 mA output is already adjusted. In case of over scale, an output will not exceed 22 mA.
- Output during inhibit or initial clear is based on 4 - 20 mA output setting in the maintenance mode. Be careful for a possible lower output which drops as low as 2.5 mA during initial clear when OSU (L alarm) is used. In particular, this occurs when the gas detector is started or the specification is changed. Understand how the gas detector functions, and take actions, if necessary, so that the receiver side cannot get false alarms (e.g. making an inhibit status).

<Communication Specifications>

Power-line communication system	The gas detector is used in a local network formed with a multi-display unit (RM-70NT) as the base unit. For more information, see the operating manual of the multi-display unit.
Ethernet	<p>The gas detector offers functions that work in liaison with external software using a standard network protocol. For details, see the separate manual for communication function.</p> <p>Web function (HTTP), mail send function (SMTP), and time synchronization function (SNTP)</p> <p>Use a Web browser of an upper-unit PC to view and change setting values and perform calibration and test on a graphical user interface.</p> <p>SMTP, when receiving a gas alarm or fault alarm from an external mail server, can send a notification mail to a registered address.</p> <p>SNTP, receiving time information from a time server, can correct the clock at regular intervals.</p> <p>Modbus slave function (Modbus/TCP)</p> <p>Works as a Modbus slave and feeds back a setting value in response to a read request or changes a setting value in response to a write request.</p> <p>PLC linkage function (FINS·MC)</p> <p>Sends a setting value to PLC to provide information to be processed by PLC in a ladder program. Reading from PLC is also available to change a setting value or perform calibration and test.</p>

6-4. Other functions

<Suppression Function>

Some types of sensor used with the gas detector are influenced by environmental changes (temperature, humidity, and other characteristics) or interference gases (interference characteristics) in no small measure, which affects the reading.

Therefore, the reading might fluctuate around zero even in a normal state with no gas leak.

This function obscures influences by environmental changes and interference gases around zero that have no meaning for your management rules of gas alarm. This function is used to hide (suppress) the fluctuation of the reading under the setting value, indicating zero.

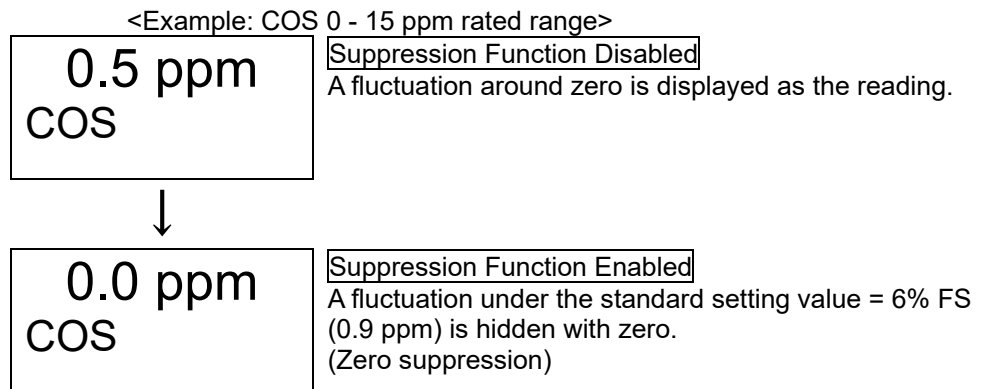

NOTE

- In the maintenance mode, this function is disabled and the fluctuation of the reading under the setting value is displayed.



CAUTION

A reading under zero is suppressed with the 10% FS suppression.
A reading that gets 10% FS or more under zero is displayed as "-0.0", which prevents an accurate gas detection and needs the zero adjustment.

<Zero Follower Function>

Some types of sensor used with the gas detector might have sensitivity variations after being used for a long period.

This function corrects the variation of the reading at the zero point (zero drift) among the sensitivity variations over time by a program manipulation to stabilize the zero point, and works on the electrochemical type (ESU) and pyrolysis-particle type (SSU).

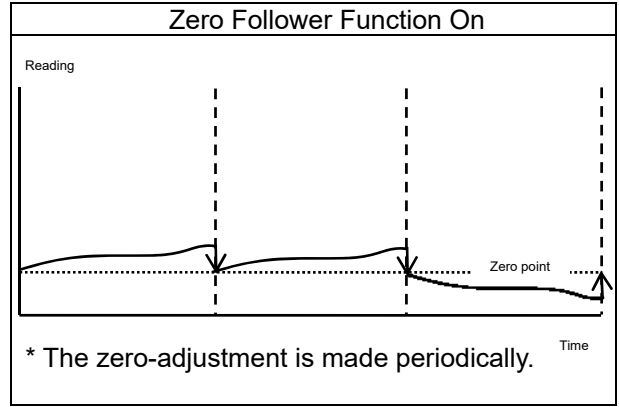
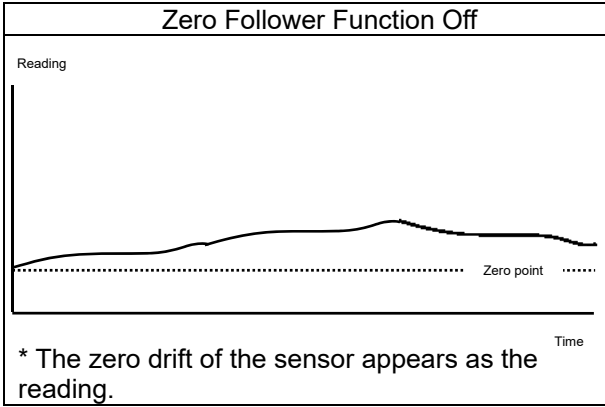

<Sensitivity Correction Function>

Some types of sensor used with the gas detector might have sensitivity variations after being used for a long period.

This function compensates the deterioration of the gas sensitivity among the sensitivity variations over time. It works on the electrochemical type (ESU) and makes the span adjustment by a program manipulation based on the principled deterioration pattern.

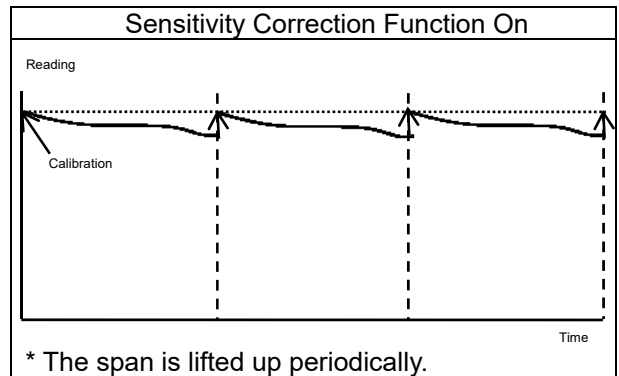
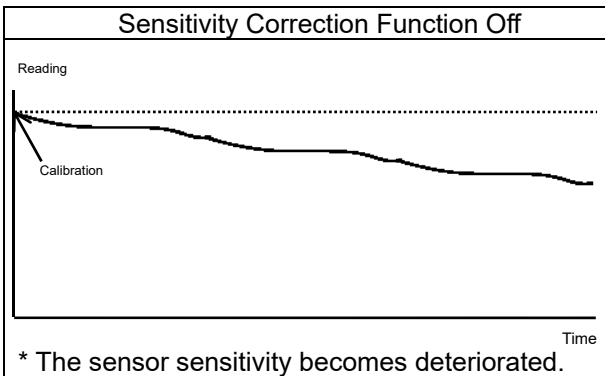

CAUTION

The sensitivity correction function is just an auxiliary function. It uniformly lifts the span up based on the principled deterioration pattern only and cannot consider the sensitivity variation of an individual sensor.

<Calibration History/Alarm Trend History/Event History Functions>

The gas detector and the sensor unit have their own history functions. To use these functions, please contact RIKEN KEIKI.

<Sensor Unit Automatic Recognition Function>

The gas detector has the function to automatically recognize the sensor unit when the sensor unit is replaced or the specification is changed. When a sensor unit with a different serial number or with a different principle or specification is attached, one of the following messages is displayed for helping the correct installation.

**Unit Replacement**

Displayed when a unit with the same specification (principle, type, and so on) is attached (e.g. in a regular replacement).

Press the MODE key to recognize the new sensor unit and start the gas detector.

The following is displayed alternately if the unit that you installed has the same or earlier date of manufacture than the one that has been replaced.

"CHG UNIT" <=> "USED SEN"

Check for correct installation if this message is displayed because an old sensor might have been installed by mistake.

**Specification Change**

Displayed when a unit with a different specification (principle, type, and so on) from the previous one is attached.

Press the MODE key to recognize the unit with the new specification and start the gas detector.

If you do not intend the specification change, this message might mean the installation error. Check the correct installation.

**CAUTION**

If you confirm the specification change (principle, sensor type, detected gases, detectable range, and so on) of the sensor unit for "C-02", the specification of the gas detector head is changed. Note that it resets the alarm setpoint (ALM P) as well as the following parameters to the standard setting values. If you want to use nonstandard setting values, set them in the maintenance mode.

- Alarm delay time setting (ALM DLY)
- Suppression value (SUPPRESS)

Please note that the data for the sensor unit with a different specification is already output to the digital data before the specification change is confirmed.

7

Maintenance

The gas detector is an important instrument for the purpose of safety. To maintain the performance of the gas detector and improve the reliability of safety, perform a regular maintenance.

7-1. Maintenance intervals and items

- Daily maintenance: Perform maintenance before beginning to work.
- Monthly maintenance: Perform maintenance on the alarm circuit (alarm test) once a month.
- Regular maintenance: Perform maintenance once or more for every six months to maintain the performance as a safety unit.

Maintenance item	Maintenance content	Daily maintenance	Monthly maintenance	Regular maintenance
Power supply check	Check that the power lamp lights up.	○	○	○
Concentration display check	Check that the concentration display value is zero. When the reading is incorrect, perform the zero adjustment after ensuring that no other gases exist around it.	○	○	○
Flow rate check	See the flow rate indicator to check for abnormalities.	○	○	○
Filter check	Check the dust filter for dust or clogging.	○	○	○
Alarm test	Inspect the alarm circuit by using the alarm test function.		○	○
Span adjustment	Perform the span adjustment by using the calibration gas.			○
Gas alarm check	Check the gas alarm by using the calibration gas.			○

<About Maintenance Services>

- We provide services on regular maintenance including span adjustment, other adjustments and maintenance.
To make the calibration gas, dedicated tools, such as a gas cylinder of the specified concentration and gas sampling bag must be used.
Our qualified service engineers have expertise, knowledge and other information on the dedicated tools used for services, along with other products. To maintain the safety operation of the gas detector, please use our maintenance service.
- Typical maintenance services are listed as follows. Please contact RIKEN KEIKI for more information.

Main services

- Power supply check : Checks the power supply voltage.
Verifies that the power lamp lights up.
(Verifies that relevant points can be identified on the system.)
(When a UPS (uninterruptible power system) is used, checks the operation with the UPS.)
- Concentration display check : Verifies that the concentration display value is zero by using the zero gas.
Performs zero adjustment if the reading is incorrect.
- Flow rate check : Checks the flow rate indicator to find abnormalities.
Checks the flow rate by using an external flow meter to verify the correctness of the flow rate indicator on the gas detector. If the flow rate is incorrect, performs the flow rate adjustment.
- Filter check : Checks the dust filter for dust or clogging.
Replaces a dirty or clogged dust filter.
- Alarm test : Inspects the alarm circuit by using the alarm test function.
 - Checks the alarm lamps. (Checks each activation of ALM1 and ALM2.)
 - Checks the external alarm. (Checks the activation of the external alarm.)
- Span adjustment : Performs the span adjustment by using the calibration gas.
- Gas alarm check : Checks the gas alarm by using the calibration gas.
 - Checks the alarm. (Checks triggering of alarm when the alarm setpoint is reached.)
 - Checks the delay time. (Checks time to delay until the alarm is triggered.)
 - Checks the alarm lamps. (Checks each activation of ALM1 and ALM2.)
 - Checks the external alarm. (Checks the activation of external alarms, such as a reset signal.)
- Cleaning and repair of the unit (visual diagnosis) : Checks dust or damage on the surface, cover or internal parts of the unit, and cleans or repairs such parts as needed.
Replaces parts which are cracked or damaged.
- Unit operation check : Uses the keys to check the operation of functions and parameters.
- Replacement of consumable parts : Replaces consumable parts, such as a sensor, filter and pump.

7-2. Regular maintenance mode



WARNING

After the adjustment is completed, never fail to press the MODE key to return to the detection mode. (If the gas detector remains in the regular maintenance mode, it automatically returns to the detection mode in ten hours.)

Mode	Item	LCD display	Details
Maintenance mode (Regular maintenance)	Gas introduction display	2-0 GAS TEST	Perform the gas introduction test in the regular maintenance mode.
	Zero adjustment => P65	2-1 ZERO	Perform zero adjustment.
	Span Adjustment => P66	2-2 SPAN	Perform span adjustment.
	Last Calibrated Date	2-3 LAST CAL	Display the last calibrated date.
	Bias voltage (element voltage)	2-4 BIAS (2-4 E VOLT)	Display the bias voltage. (Display the element voltage.) => <u>Element voltage is not used on the gas detector.</u>
	Flow Rate Setting (adjusted to 0.5 L/min)	2-5 DEF FLOW	Not used.
	Flow rate manual adjustment	2-6 FLOW	Display the output and flow rate of the current pump.
	Detector temperature	2-7 TEMP	Display the current temperature of the installation environment.
	Expected warm-up completion date/time	2-8 WARMTIME	Display the expected warm-up completion for semiconductor type (SGU). => <u>This is not used on the gas detector.</u>
	Environmental setting 1 => P51	2-9 SETTING1	Operation setting SET 0. INHIBIT: INHIBIT setting SET 1. ALMP: Alarm value setting => P52 SET 2. ALM DLY: Alarm delay time setting SET 3. MAINT: Regular replacement operation (pump stop) => <u>This is not used on the gas detector.</u> SET 4. F TEST: Fault alarm test => P52
Environmental setting 2 => P53	2-10 SETTING2	Functions setting SET 0. ADDRESS: Address setting SET 1. DAY TIME: Date and time setting => P58 SET 2. SUPPRESS: Zero suppression value setting SET 3. SUP TYPE: Zero suppression type setting SET 4. TEST RLY: Contact setting for alarm test SET 5. TEST4-20: External output setting for alarm test SET 6. RLY PTRN: Energized/De-energized setting => P59 SET 7. ALM TYP: Alarm type setting => <u>Not used on the gas detector.</u> SET 8. ALM PTRN: Alarm pattern setting SET 9. AL LIMIT: Alarm value limiter setting SET 10. FLT PTRN: Fault activation setting SET 11. AT FLOW: Flow rate auto-adjustment setting SET 12. ZERO F: Zero follower ON/OFF setting SET 13. ZERO 24F: 24 hours zero follower ON/OFF setting SET 14. S ASSIST: Sensitivity correction ON/OFF setting SET 15. MNT OUT: External output in maintenance mode setting SET 16. MA 4-20: External output adjustment SET 17. BK LIGHT: Backlight setting SET 18. ETHERNET: Ethernet setting => P60 SET 19. PUMP CK: Pump drive level diagnosis ON/OFF setting	

Mode	Item	LCD display	Details
	Pyrolyzer data display => P62	2-11 PL DATA	Display various pyrolyzer data.
	Fault investigation	2-12 FAULT	Not used.
	Catalyst aging function => P64	2-13 PL AGING	Perform aging of catalyst.
	Factory mode	2-14 F MODE	Not used.

User Mode
In "1-8. M MODE",
press the SET key.

PW A1 A2 F

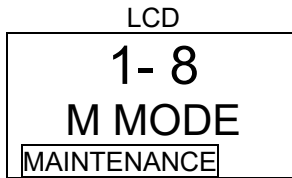

PW: POWER ●: Lamp on
A1: ALM1 ○: Lamp off
A2: ALM2
F: FAULT

↓
Then press the SET key
again for three seconds.

● ○ ○ ○

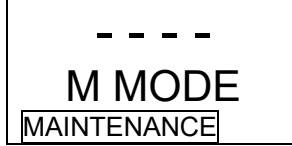

↓
**Regular maintenance
mode**

2-0. GAS TEST
Perform a test with the
gas.
Similar to the detection
mode, the reading
changes and the alarm
lamp lights up after the
gas is introduced, but
the contact is not
activated.

● ○ ○ ○



→
SET

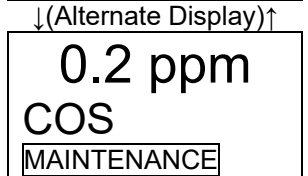
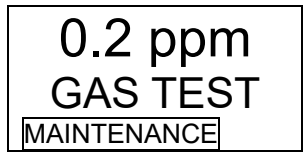

2-1. ZERO
Perform zero
adjustment.

● ○ ○ ○

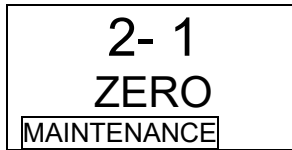

→
SET

Zero adjustment
=> **P65**

2-2. SPAN
Perform span
adjustment.

● ○ ○ ○

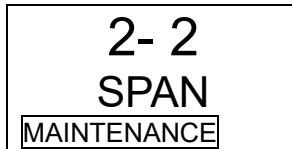

→
SET

Span adjustment
=> **P66**

2-3. LAST CAL
Display the last
calibrated date.

● ○ ○ ○



→
SET

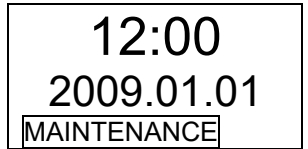

2-4. BIAS
Display the bias voltage
"BIAS" of
electrochemical type
(ESU) or the element
voltage "E VOLT" of
semiconductor type
(SGU).

● ○ ○ ○



→
SET

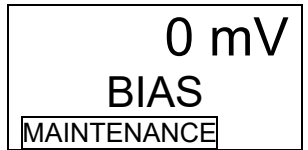

* Element voltage is not
used on the gas
detector.

2-5. DEF FLOW
 This is not used on the gas detector.

- ○ ○ ○ ○

▲ ↓ ↑ ▼

2- 5
 DEF FLOW
 MAINTENANCE

▲ | | ▼

⇔
SET

1000
 DEF FLOW
 MAINTENANCE

2-6. FLOW
 Display the output and flow rate of the current pump.

- ○ ○ ○ ○

▲ ↓ ↑ ▼

2- 6
 FLOW
 MAINTENANCE

⇔
SET

50%
 0.50 L/M
 MAINTENANCE

2-7. TEMP
 Display the temperature of the gas detector.

- ○ ○ ○ ○

▲ ↓ ↑ ▼

2- 7
 TEMP
 MAINTENANCE

→
SET

25.0°C
 TEMP
 MAINTENANCE

2-8. WARMTIME
 Display the suggested warm-up completion date/time for semiconductor type (SGU), which requires a long warm-up time.
 * This is not used on the gas detector.

- ○ ○ ○ ○

▲ ↓ ↑ ▼

2- 8
 WARMTIME
 MAINTENANCE

▲ ↓ ↑ ▼

→
SET

12:00
 2009.01.01
 MAINTENANCE

2-9. SETTING1
 Specify the environmental setting 1.

- ○ ○ ○ ○

▲ ↓ ↑ ▼

2- 9
 SETTING1
 MAINTENANCE

→
SET

Environmental Setting
 1 => P51

2-10. SETTING2
 Specify the environmental setting 2.

- ○ ○ ○ ○

▲ ↓ ↑ ▼

2-10
 SETTING2
 MAINTENANCE

→
SET

Environmental setting
 2 => P53

2-11. PL DATA
 Display the pyrolyzer data.

- ○ ○ ○ ○

▲ ↓ ↑ ▼

2-11
 PL DATA
 MAINTENANCE

▲ ↓ ↑ ▼

→
SET

Pyrolyzer data display
 => P62

2-12. FAULT

This is used (by the manufacturer) to investigate and analyze the causes of faults. This is not used by the user.



2-13. PLAGING

Used to perform aging of catalyst.



→ SET Catalyst aging function => P64

2-14. F MODE

Enter the factory mode. This is not used by the user.

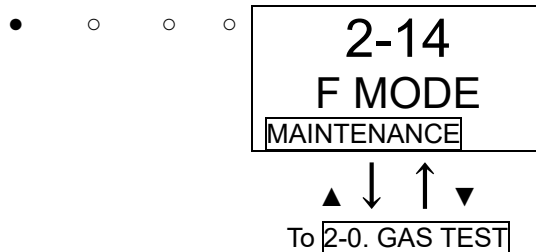

<Environmental Setting 1 "2-9">

In the environmental setting 1, specify the operation setting.

<Environmental Setting 1> PW A1 A2 F LCD

2-9. SETTING1

Press SET key.

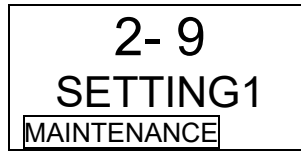

SET 0. INHIBIT

Set the inhibit.
Select either ON/OFF,
and then press the SET
key to confirm the
selection.

When ON is selected,
the message **INHIBIT**
is displayed on the
LCD. As a result, an
alarm is not triggered to
external circuits even
though the gas detector
is in the detection
mode.

• ○ ○ ○ ○

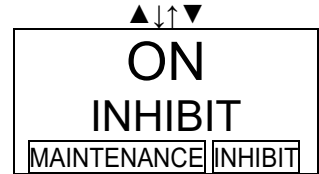
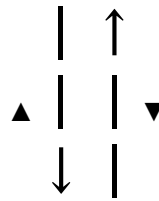

SET 1. ALM P

Set the alarm value.

• ○ ○ ○ ○



⇔ Alarm value setting
SET => **P52**



SET 2. ALM DLY

Set the alarm delay
time.

Change the value
(second) by pressing
the ▲ or ▼ key, and
then press the SET key
to confirm the value.

• ○ ○ ○ ○



SET 3. MAINTE

* This is not used on
the gas detector.

• ○ ○ ○ ○

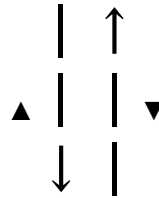

SET 4. F TEST

Perform a fault alarm
test.

• ○ ○ ○ ○



⇔ Fault Alarm Test
SET => **P52**



To **SET 0. INHIBIT**
Setting

<Alarm Value Setting "2-9" - "SET 1">

SET 1. ALM P
Press SET key.

PW A1 A2 F
● ○ ○ ○

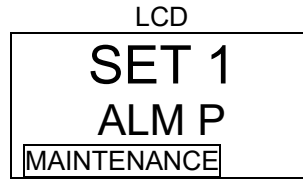

First alarm value setting
Change the value by pressing the ▲ or ▼ key, and then press the SET key to confirm the value. (Press the MODE key to skip this menu.)

● ○ ○ ○

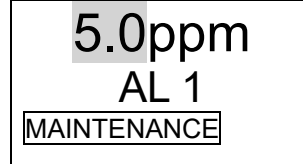

Second alarm value setting
Change the value by pressing the ▲ or ▼ key, and then press the SET key to confirm the value. (Press the MODE key to skip this menu.)

● ○ ○ ○

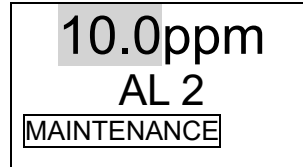

Return to
SET 1. ALM P

<Fault Alarm Test "2-9" - "SET 4">

SET 4. F TEST
Press SET key.

PW A1 A2 F
● ○ ○ ○

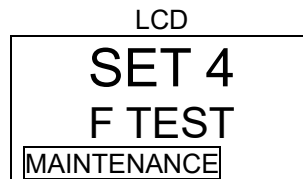

Fault Alarm Test ON/OFF
Select either ON/OFF.
Switch ON and press the SET key to trigger the fault alarm.
Return to OFF and press the SET key to cancel the test.
(Pressing the MODE key also enables to cancel this menu and to go back to the original state.)

● ○ ○ ○

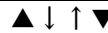

● ○ ○ ●



WARNING

Be careful to perform the fault alarm test, because it is the only way that the contact (fault) may be activated even in the maintenance mode. The fault alarm test cannot be performed during inhibit.

<Environmental Setting 2 "2-10">

In the environmental setting 2, specify the settings of functions. (* It is recommended that setting changes should be recorded in a log.)

The environmental setting 2 includes setting menus which are usually not used. Be careful not to change these settings by mistake.

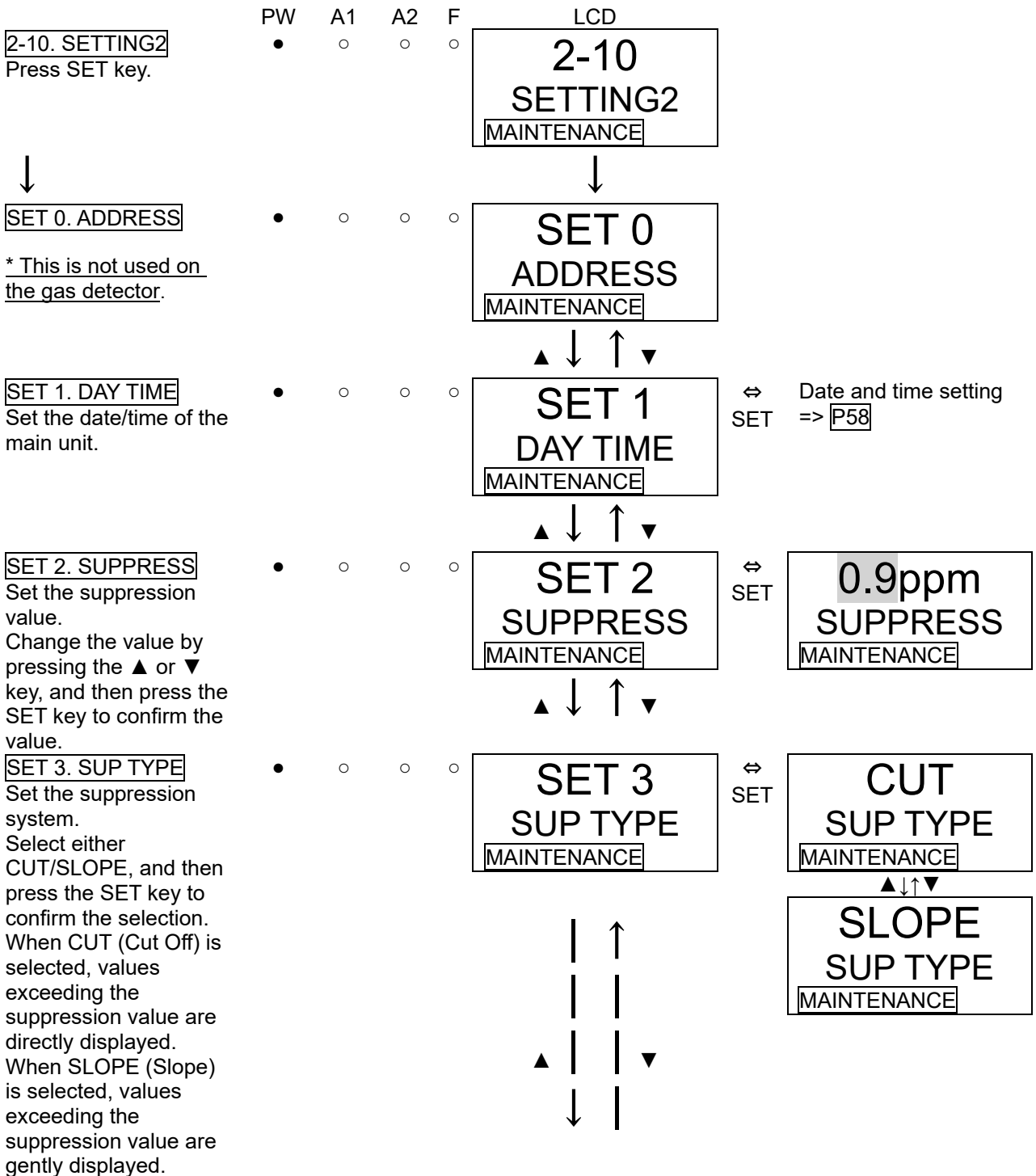

SET 4. TEST RLY

Set the contact activation for an alarm test.
 Select either ON/OFF, and then press the SET key to confirm the selection.
 When ON is selected, the contact can be activated even during an alarm test.

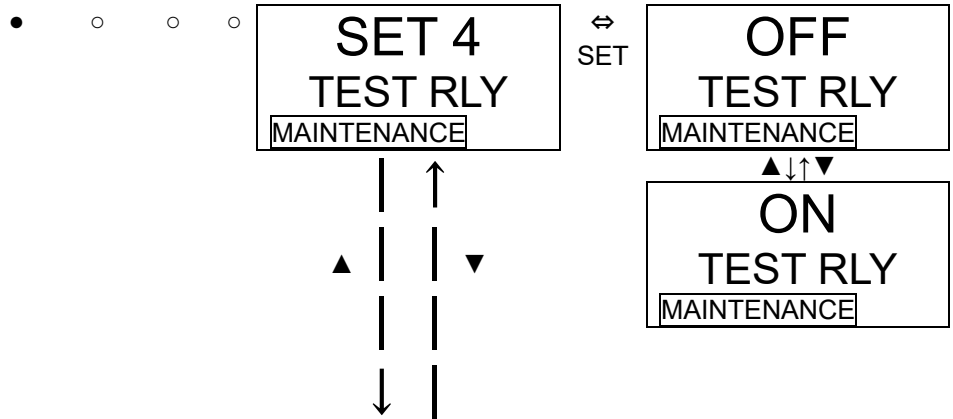

SET 5. TEST4-20

Set the external output for an alarm test.
 Select either ON/OFF, and then press the SET key to confirm the selection.
 When ON is selected, the external output (4 - 20 mA) is output even during an alarm test.
 When OFF is selected, the output is kept at the one just before the alarm test mode is entered (HOLD).

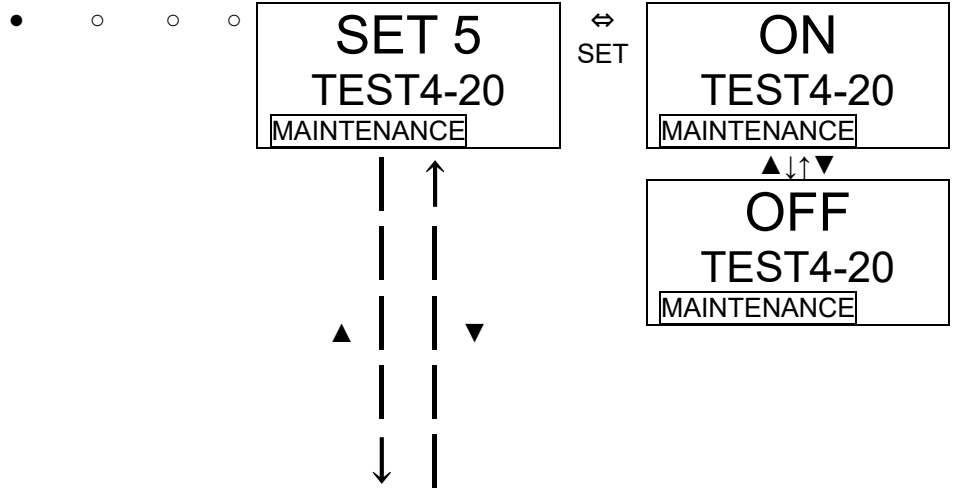

SET 6. RLY PTRN

Select either energized/de-energized for the contact.

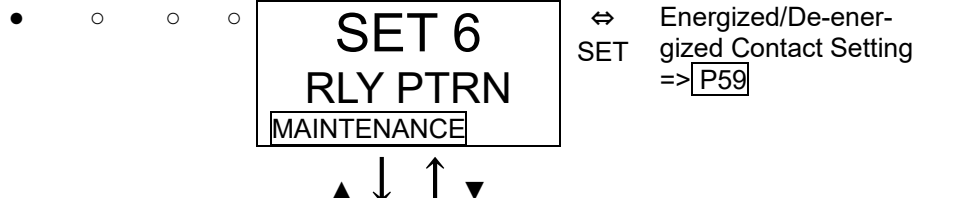

SET 7. ALM TYPE

Set the alarm type.
 * This is not used on the gas detector.

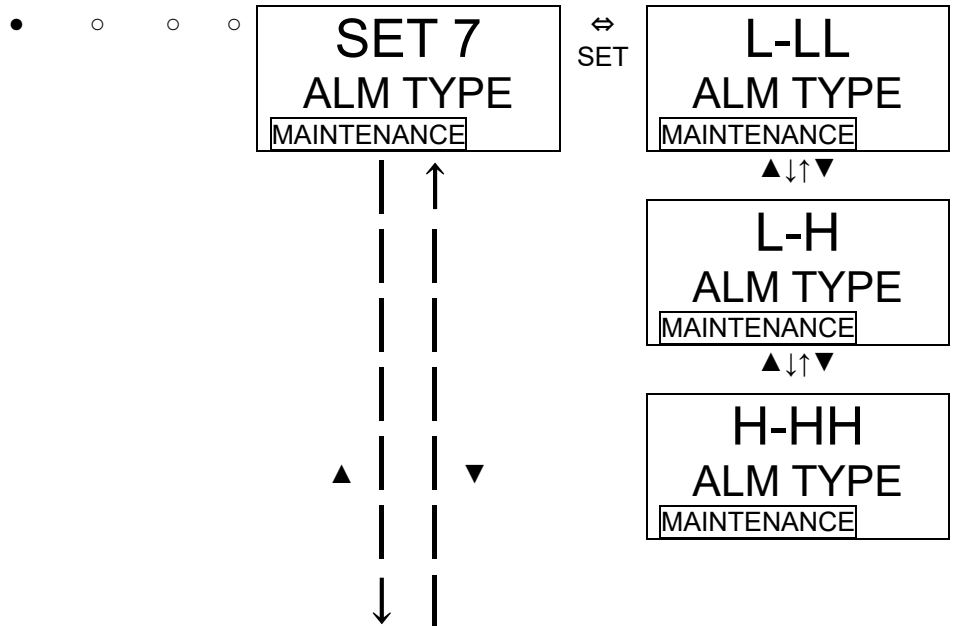

SET 8. ALM PTRN

This is a setting screen of the gas alarm pattern. Do not change the setting when the gas detector is used in a normal way, because it determines how the gas detector functions. (Auto-reset setting: "nL")

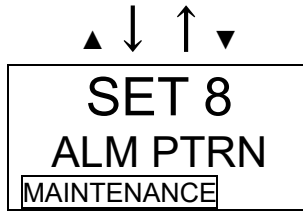

- ○ ○ ○ ○

SET 9. AL LIMIT

This is a setting screen of the alarm value limiter. Do not change the setting when the gas detector is used in a normal way. (ON setting)



- ○ ○ ○ ○

SET 10. FLT PTRN

This is a setting screen of the fault alarm pattern. Do not change the setting when the gas detector is used in a normal way, because it determines how the gas detector functions. (Auto-reset setting: "nL")



- ○ ○ ○ ○

SET 11. AT FLOW

Set the flow rate auto-adjustment. Select either ON/OFF, and then press the SET key to confirm the selection. When ON is selected, the flow rate auto-adjustment is activated.

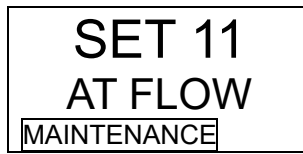

- ○ ○ ○ ○

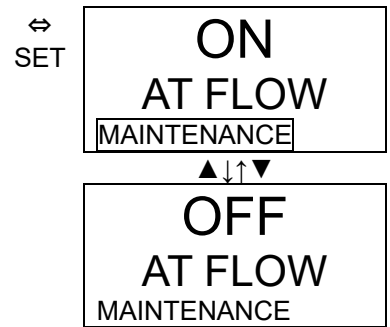

SET 12. ZERO F

Set the zero follower when the electrochemical type (ESU) or the pyrolysis-particle type (SSU) is installed. Select either ON/OFF, and then press the SET key to confirm the selection. When ON is selected, the zero follower function is activated.

* When SSU is installed, it must always be set to ON.



- ○ ○ ○ ○

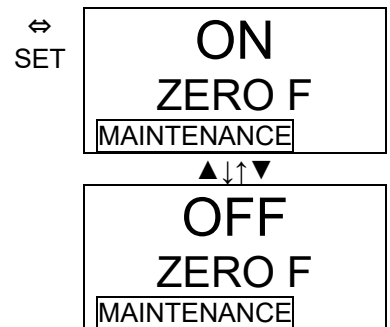

SET 13. ZERO 24F

This is a supplemental setting screen for the above zero follower function. (A setting to determine whether the first-24-hour zero follower will be performed after the power is turned on.) Do not change the setting when the gas detector is used in a normal way. (ON setting)

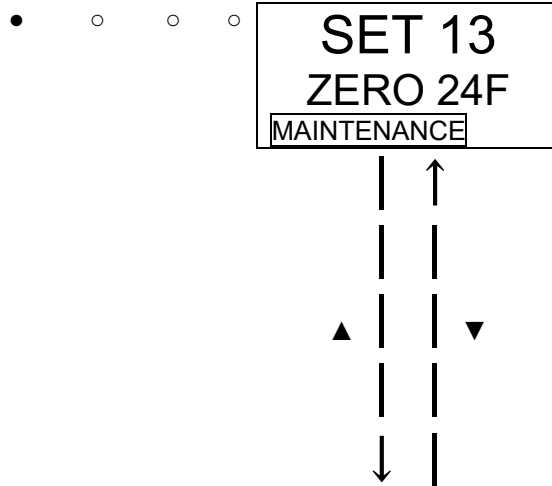

SET 14. S ASSIST

Set the sensitivity correction when the electrochemical type (ESU) is installed. Select either ON/OFF, and then press the SET key to confirm the selection. When ON is selected, the sensitivity correction function is activated.

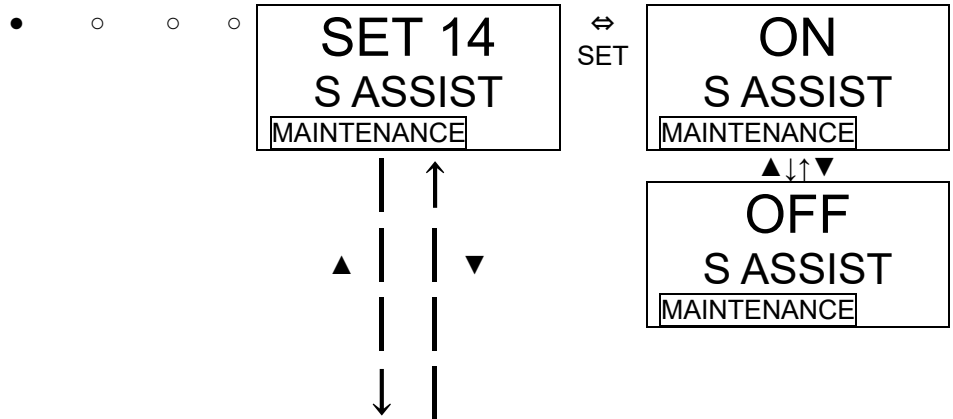

SET 15. MNT OUT

Set the external output for the maintenance mode. Select either 2.5 mA/4.0 mA/HOLD (previous value)/4 - 20 mA (linked to display value), and then press the SET key to confirm the selection. (4 - 20 mA specification)

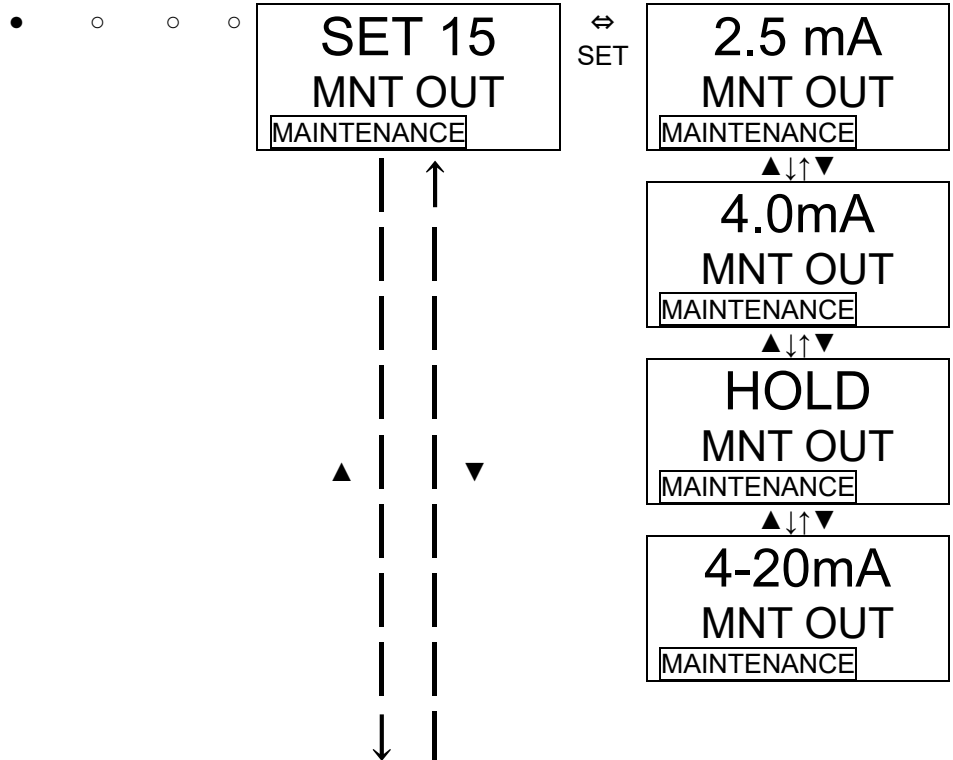

SET 16. MA 4-20

Adjust the external output (4 - 20 mA). Adjust the output (%) by pressing the ▲ or ▼ key, and then press the SET key to confirm the value.

(It must be adjusted to the upper unit or the ammeter.)

After adjustment of 4 mA is completed, perform the adjustment of 20 mA.

(Press the MODE key to skip this menu.)

(4 - 20 mA specification)

- ○ ○ ○ ○

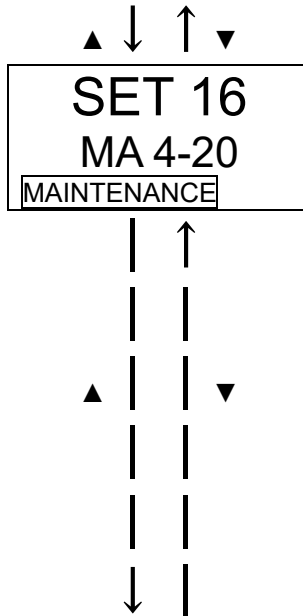

SET 17. BK LIGHT

Set the backlight. Select either ON/SAVE, and then press the SET key to confirm the selection.

When ON is selected, the backlight lights up continuously.

When SAVE is selected, the backlight is usually turned off, but lights up only during an operation or event.

- ○ ○ ○ ○

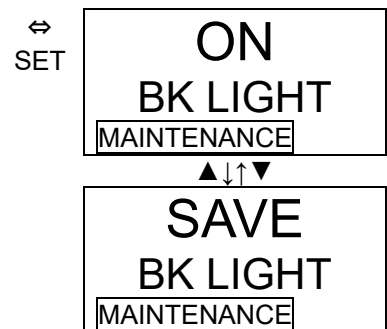
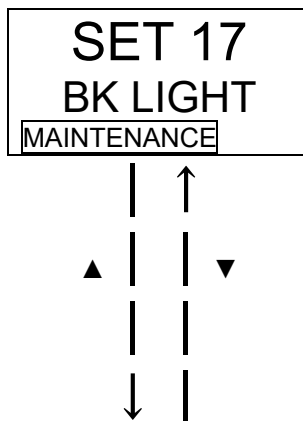

SET 18. ETHERNET

Set Ethernet.

- ○ ○ ○ ○



ETHERNET setting => P60

SET 19. PUMP CK

Set the pump drive level diagnosis. Select either ON/OFF, and then press the SET key to confirm the selection.

When ON is selected, the message "FLOW" is displayed if the flow rate is sufficient even though the pump drive level is low. (A function to check the conditions for applying pressure, etc.)

- ○ ○ ○ ○

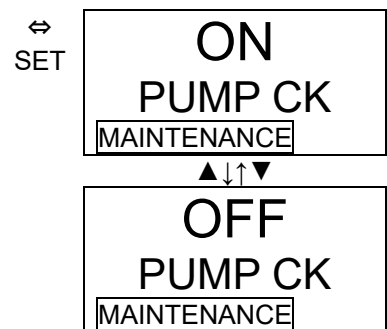
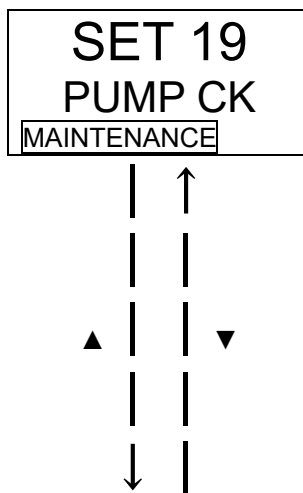

To SET 0. ADDRESS

<Date/Time Setting "2-10" - "SET 1">

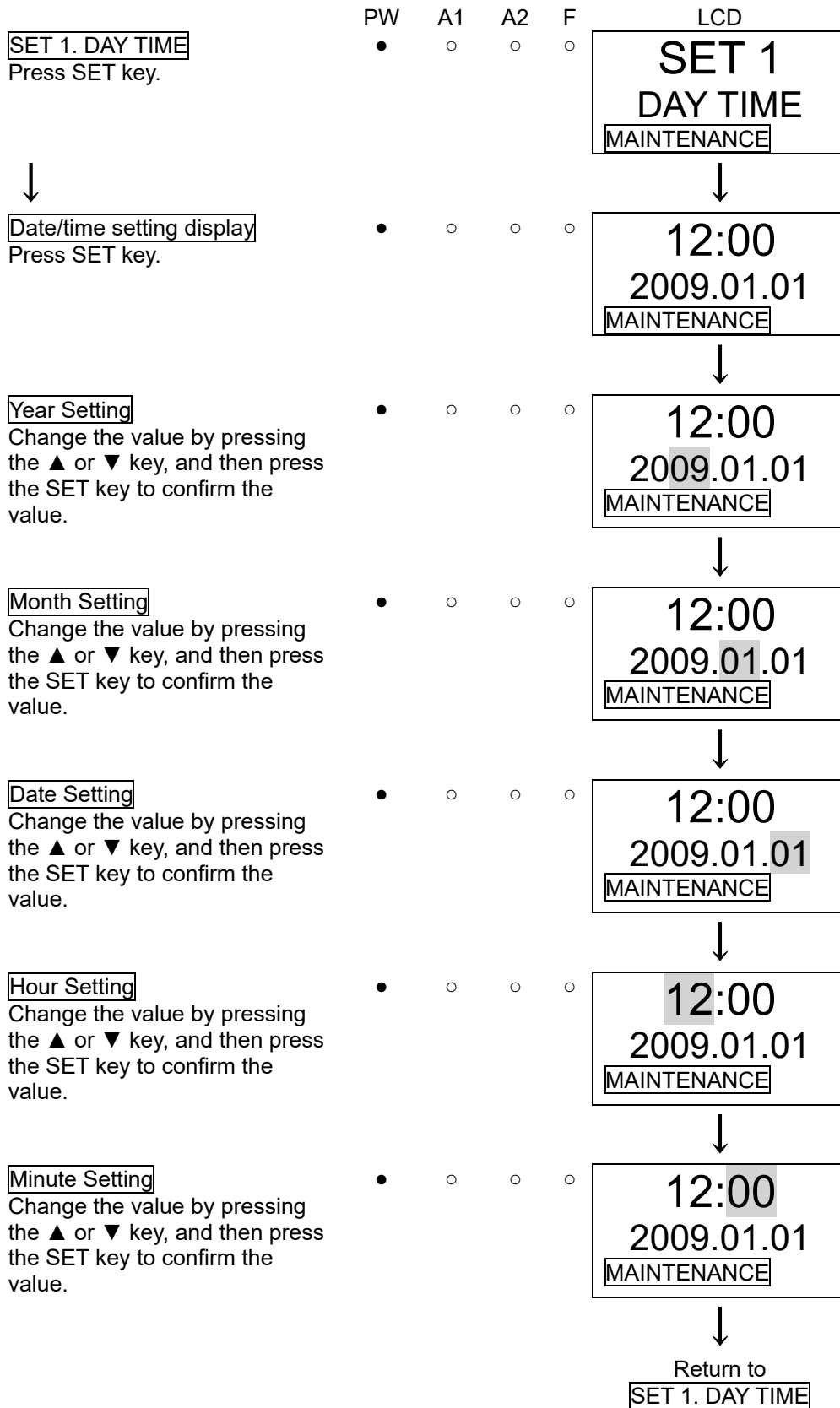

* In the Date/Time Setting mode, press the MODE key to cancel this menu and go back to the previous setting.

<Energized/De-energized Setting “2-10” - ”SET 6”>

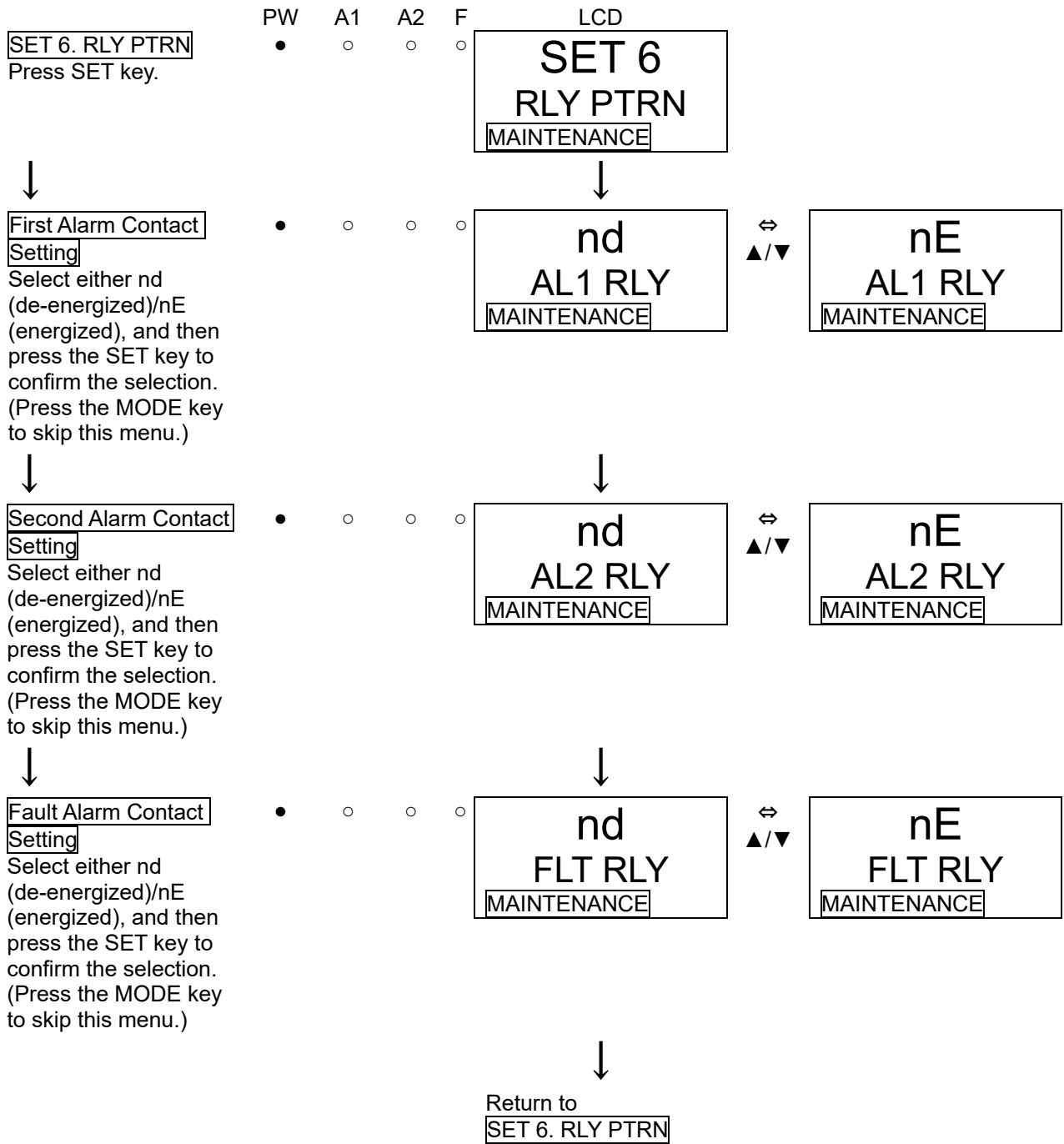

NOTE

When de-energized is selected, the relay is energized and activated at an alarm state (de-energized at a normal state).

- When the "a" contact is used, it is open at a normal state while closed at an alarm state.
- When the "b" contact is used, it is activated conversely.

When energized is selected, the relay is energized at a normal state (de-energized at an alarm state).

- When the "a" contact is used, it is closed at a normal state while open at an alarm state. In addition, it is closed when the power is OFF.
- When the "b" contact is used, it is activated conversely.

<ETHERNET Setting "2-10" - "SET 18">

PW
 A1
 A2
 F
 LCD
SET 18. ETHERNET
 Press SET key.

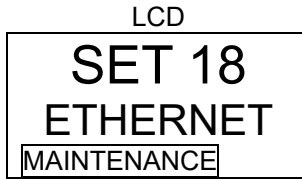

↓

MAC Address Check
 There are MAC addresses from MAC1 to MAC6. Select one using ▲ and ▼ keys and display them one by one in the same way.
 * MAC addresses are fixed values unique to the unit.

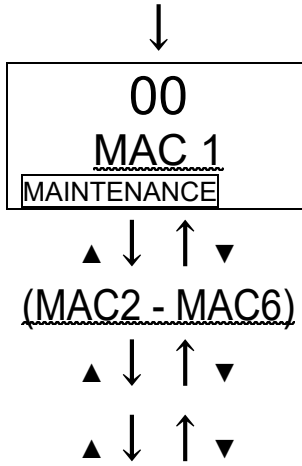

IP Address Setting
 Change the value by pressing the ▲ or ▼ key, and then press the SET key to confirm the value.

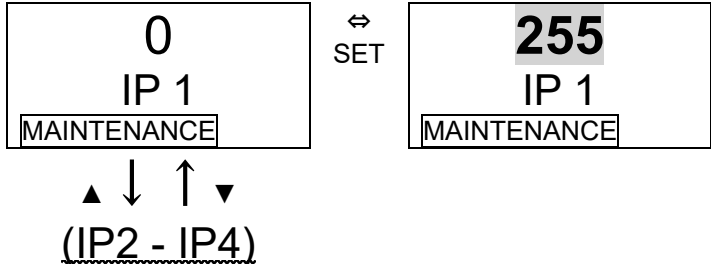

There are IP addresses from IP1 to IP4. Select one using ▲ and ▼ keys and set them one by one in the same way.

Subnet Mask Setting
 Change the value by pressing the ▲ or ▼ key, and then press the SET key to confirm the value.

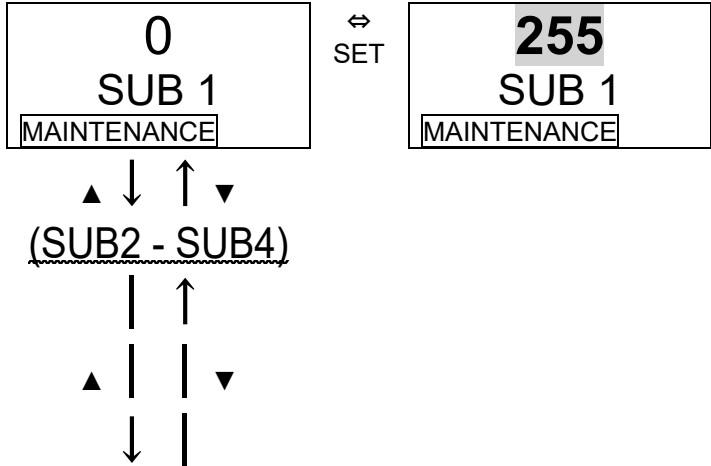

There are subnet masks from SUB1 to SUB4. Select one using ▲ and ▼ keys and set them one by one in the same way.

Default Gateway Setting

Change the value by pressing the ▲ or ▼ key, and then press the SET key to confirm the value.

There are default gateways from DEF1 to DEF4. Select one using ▲ and ▼ keys and set them one by one in the same way.

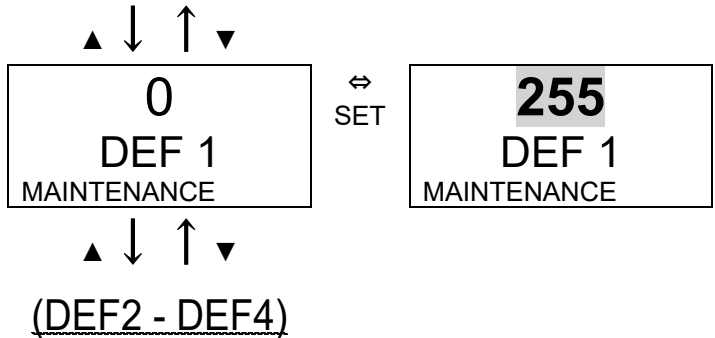

DHCP Setting

Select either ON/OFF, and then press the SET key to confirm the selection.

When ON is selected, an IP address is automatically obtained from the DHCP server. In this case, the IP1 to IP4, SUB1 to SUB4, and DEF1 to DEF4 settings are disabled.

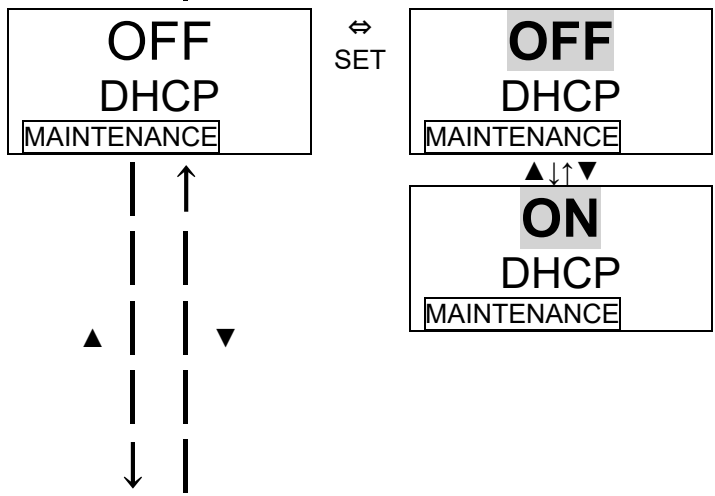

Setting result record

To record the results of the settings made in the above, press the SET key.

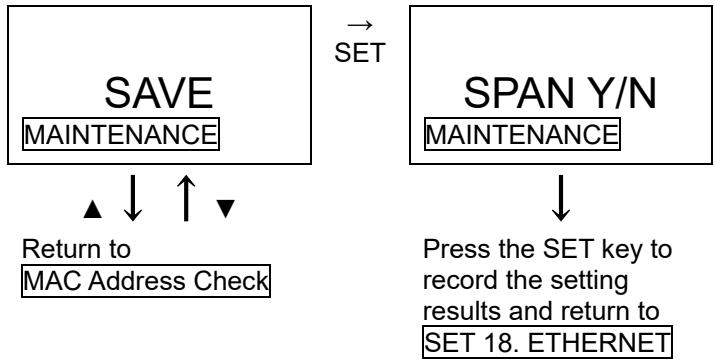

* In ETHERNET mode, it is necessary to record setting results after all the settings have been selected. Press the MODE key before completion to undo all the changes that have been made.

NOTE

It takes 10 seconds or more for the address settings to be recorded and for the settings to take effect on the system. (Particularly for DHCP, the time it takes depends on the environment.) While the settings are putting into effect, "0" is displayed for all of MAC1 - 6, IP1 - 4, SUB1 - 4 and DEF1 - 4, and none of the Ethernet functions is available.

<Pyrolyzer Heater Data Display "2-11">

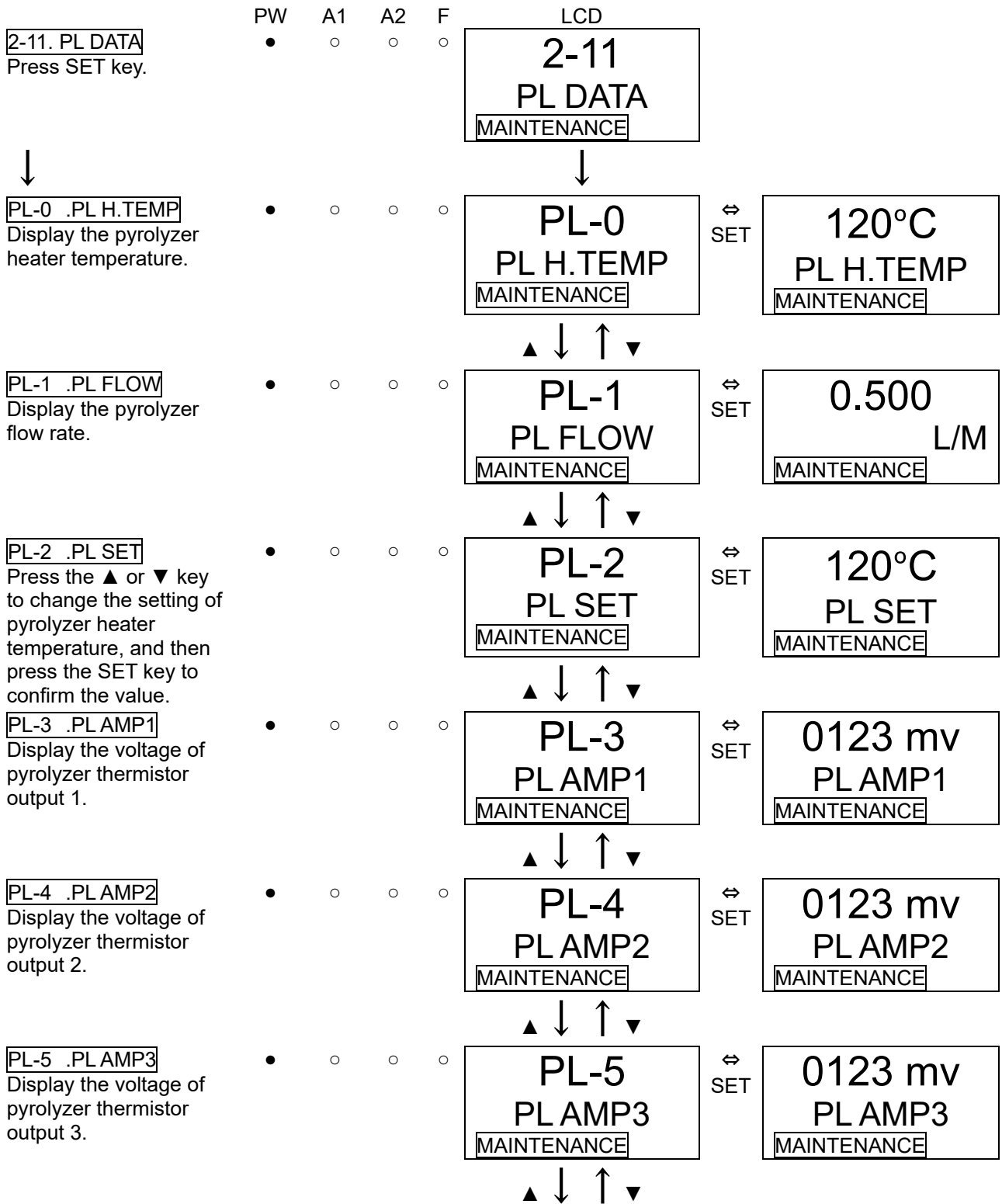

PL-6 .PL 3.3V
 Display the pyrolyzer
 3.3 V output.

- ○ ○ ○ ○

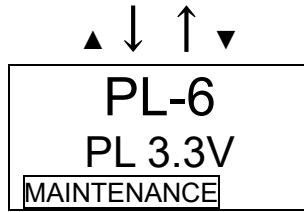

⇔
SET

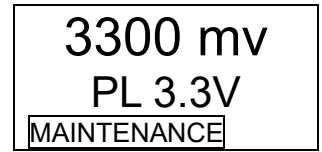

PL-7 .PL 5.0V
 Display the pyrolyzer
 5.0 V output.

- ○ ○ ○ ○

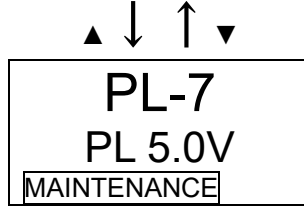

⇔
SET

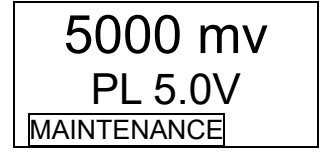

PL-8 .PL VER
 Display the pyrolyzer
 version.

- ○ ○ ○ ○

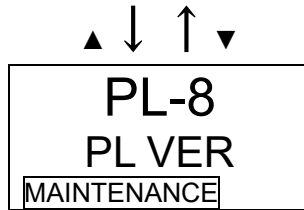

⇔
SET

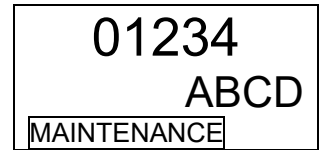

PL-9 .PL F AD
 Display the voltage
 output of pyrolyzer flow
 rate.

- ○ ○ ○ ○

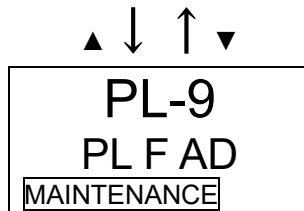

⇔
SET

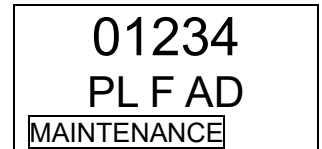

<Catalyst Aging Function “2-13”>

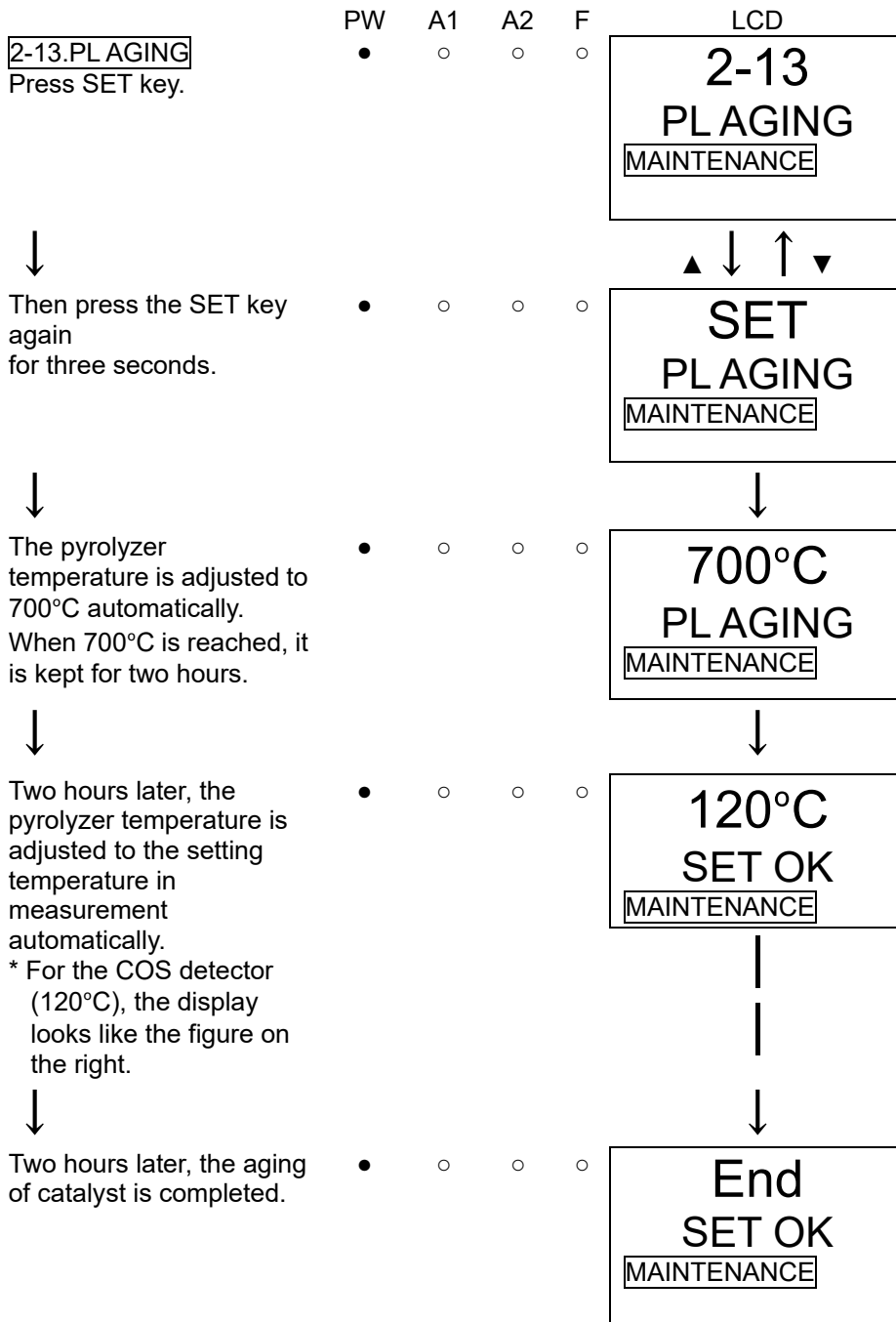

7-3. Calibration method

Perform a calibration in each mode (zero adjustment mode and span adjustment mode) using the calibration gas.

- Zero adjustment gas (collected in a gas sampling bag)
- Calibration gas (collected in a gas sampling bag)
- Gas sampling bag for exhaust gas

WARNING

After the adjustment is completed, never fail to press the MODE key to return to the detection mode.

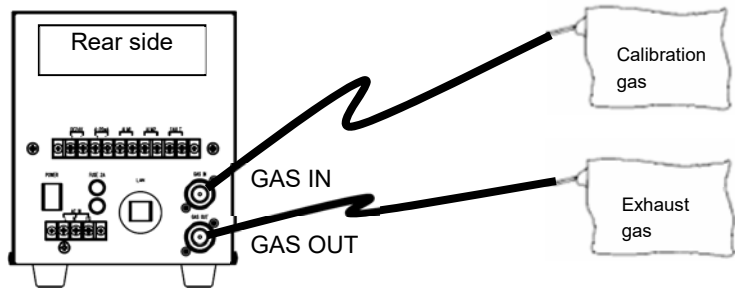

<Zero Adjustment "2-1">

This is used to perform the zero adjustment.

WARNING

When the zero adjustment is performed in the atmosphere, check the atmosphere for freshness before beginning the adjustment. If interference gases exist, the adjustment cannot be performed properly, thus leading to dangers when the gas leaks.

NOTE

Before starting the zero adjustment, let the gas detector draw the zero adjustment gas and wait until the reading is stabilized.

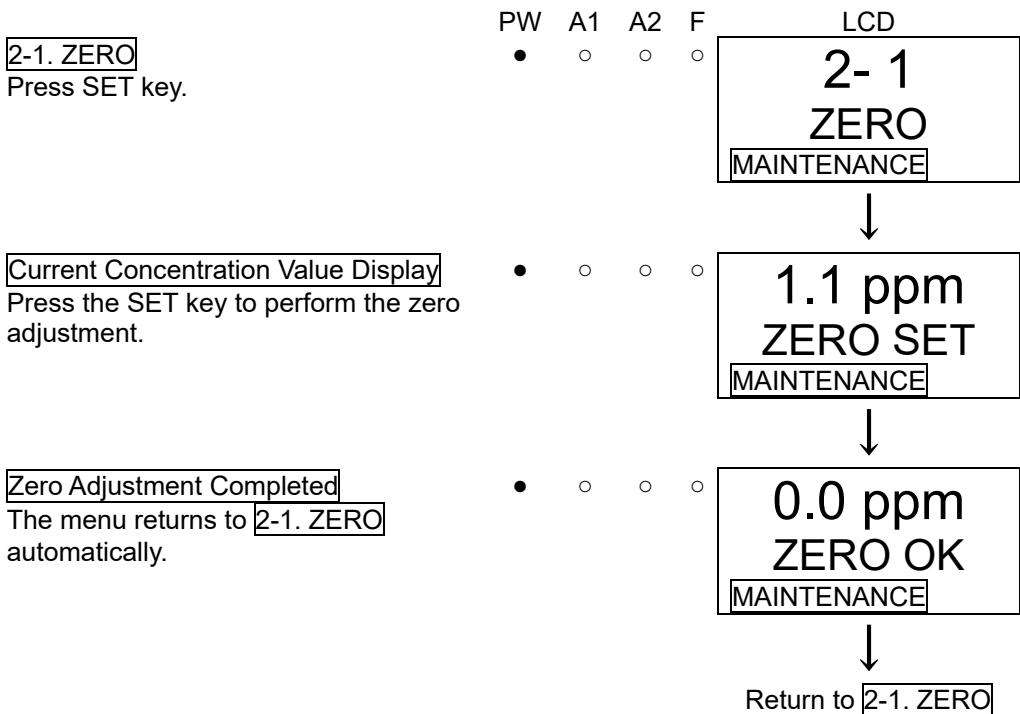

* When the zero adjustment fails

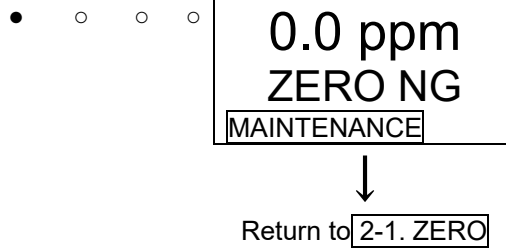

This is used to perform the span adjustment.

2-2. SPAN
Press SET key.

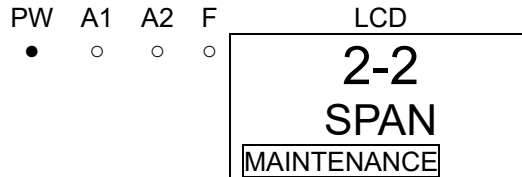

↓

Gas introduction
Introduce a gas, and then press the SET key when the reading is stabilized.
* In case of less than 10%FS, this is not switched to the next menu.



CAUTION

Do not press the SET key before the reading is stabilized.

↓

Span Adjustment
Because the reading will be fixed, adjust the introduced gas concentration by pressing the ▲ or ▼ key. After adjusting the value, press the SET key.

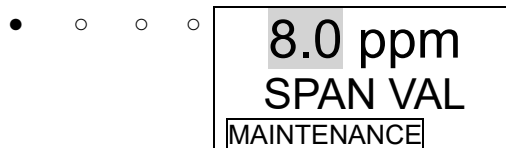

↓

Span Adjustment Completed

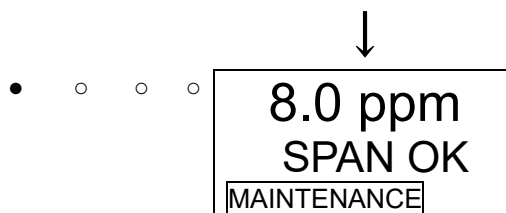

↓

Adjustment result record
To record the adjustment result, press the SET key.
(Press the MODE key to cancel this menu.)



Adjustment Completed
The menu returns to 2-2. SPAN automatically.

 **CAUTION**
Exhaust gas must be collected in the exhaust bag or discharged through the exhaust line.

- ○ ○ ○

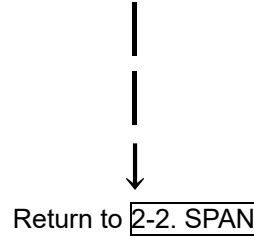
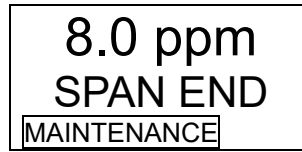

* When the span adjustment fails

- ○ ○ ○

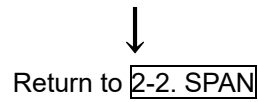
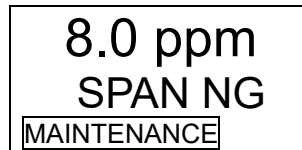

7-4. Other adjustments/cleaning method

<Flow Rate Manual Adjustment "2-6">

The flow rate of the gas detector is automatically adjusted to 0.5 L/min. Turning off the auto-adjustment function enables the manual adjustment. (See "2-10" - "SET 11")

The manual flow rate adjustment can be performed in the regular maintenance mode "2-6. FLOW".

2-6. FLOW

Press SET key.

PW A1 A2 F

LCD

**2-6
FLOW**
 MAINTENANCE



Flow Rate Adjustment

As the output is increased or decreased by pressing the ▲ or ▼ key, the flow rate changes accordingly. Adjust the flow rate to 0.5 L/min, and then press the SET key.

(Press the MODE key to cancel this menu.)

**50%
0.50 L/M**
 MAINTENANCE



WARNING

After the adjustment is completed, never fail to press the MODE key to return to the detection mode.

<Cleaning of Gas Detector>

Clean the gas detector if it becomes extremely dirty. The gas detector must be turned off while cleaning it. Use a waste cloth to remove dust. Do not use water or organic solvent for cleaning because they may cause malfunctions.

Because an extremely large amount of dust inside the tube may disturb the gas detection, it must be cleaned with dry AIR, etc.

7-5. How to replace parts

<Replacement of Consumables>

External Dust Filter Replacement

Because the external dust filter may gradually get dirty or clogged over the time, it must be replaced regarding the operating conditions. Check the external dust filter, and then replace it as necessary.

Fuse replacement

Make sure that the power switch of the main unit is turned OFF and the power plug is disconnected from the outlet.

While pushing the fuse holder, turn it counterclockwise by approximately 90 degrees and pull it out (see the right figure).

Replace the fuse with new one.

Return the fuse holder, and push and turn it clockwise by approximately 90 degrees.

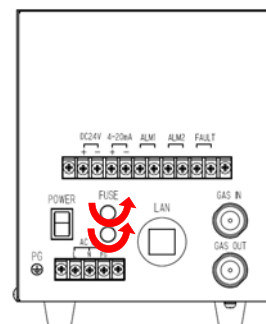

WARNING

To prevent fire, use a fuse with the specified ratings (3.15A, 250V and Time Lag) for the gas detector. Turn the POWER switch OFF and disconnect the power plug from the outlet before replacing a fuse. Do not use an unspecified fuse or short-circuit the fuse holder.

<Replacement of Regular Replacement Parts>

List of recommended regular replacement parts

No.	Name	Maintenance intervals	Replacement intervals	Quantity (pieces/unit)
1	Pump unit	0.5 years	1 - 2 years	1
2	Flow sensor	1 year	5 years	1
4	Fan	0.5 years	2 - 4 years	1
5	Catalyst tube	0.5 years	1 year	1
6	Sensor unit	0.5 years	1 year	1
7	Tubes and joints	0.5 years	3 - 8 years	-
8	C4F6/C5F8 silica gel filter	0.5 years	2 years	1

NOTE

- The above replacement intervals are recommendation only. The intervals may change depending on the operating conditions. These intervals do not mean the warranty periods either.
- After the sensor unit or catalyst tube is replaced, always perform a calibration (zero adjustment and span adjustment).
- There are two types of sensor units and catalyst tubes: one for C4F6/C5F8 and the other for COS. Replace them with appropriate ones.
- To reduce the frequency of calibration, it is recommended that the sensor unit and catalyst tube be replaced at the same time.

Replacement of Pump Unit

For the replacement of pump unit, see "Detaching and Attaching Pump Unit" in "3-3. Names and functions for each part".

Replacement of flow sensor, fan and catalyst tube

After the flow sensor, fan or catalyst tube is replaced, the operation must be checked by a qualified service engineer. Since the catalyst tube has an influence over gas sensitivity, calibration needs to be performed after replacement. Please contact RIKEN KEIKI.

Sensor Unit Replacement

For the replacement of sensor unit, see "Detaching and Attaching Sensor Unit" in "3-3. Names and functions for each part". Since the sensor unit has an influence over gas sensitivity, calibration needs to be performed after replacement.

**CAUTION**

- Turn OFF the power when the sensor unit is replaced.

8

Storage, Relocation and Disposal

8-1. Procedures to store the gas detector or leave it for a long time

The gas detector must be stored under the following environmental conditions.

- In a dark place under the normal temperature and humidity away from direct sunlight
- In a place where gases, solvents or vapors are not present

8-2. Procedures to relocate the gas detector or use it again

When the gas detector is relocated, select a new place in accordance with "4-2. Precautions for installation sites".

For information on wiring and tubing, see "4-4. How to wire" and "4-5. How to Tube". The unpowered time must be minimized when the gas detector is relocated.



CAUTION

When using a relocated or stopped/stored detector again, never fail to perform a calibration. For information on readjustment including calibration, please contact RIKEN KEIKI.

8-3. Disposal of products

- A used sensor unit must be returned to us. Please return the sensor unit to RIKEN KEIKI.
- If liquid is leaked from the electrochemical type sensor unit (ESU), do not touch the liquid. The sensor unit must be put into a plastic bag to prevent leaking.
If liquid is leaked from the sensor of the gas detector, turn "OFF" the power and contact RIKEN KEIKI immediately.
- When the gas detector is disposed of, it must be treated properly as an industrial waste in accordance with the local regulations.



WARNING

- Do not disassemble the electrochemical type sensor unit (ESU) because it contains electrolyte. Electrolyte may cause severe skin burns if it contacts skin, while it may cause blindness if it contacts eyes. If electrolyte is adhered on your clothes, that part on your clothes is discolored or its material is decomposed. If contact occurs, rinse the area immediately with a large quantity of water.

Troubleshooting

The troubleshooting does not explain the causes of all the malfunctions which occur on the gas detector. This simply helps to find the causes of malfunctions which frequently occur. If the gas detector shows a symptom which is not explained in this manual, or still has malfunctions even though remedial actions are taken, please contact RIKEN KEIKI.

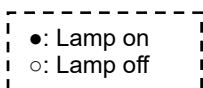

<Abnormalities on Unit>

Symptom/Display	FAULT	Causes	Actions
<u>The power cannot be turned on.</u>	—	The power switch is turned off.	Turn ON the power switch.
		Abnormalities/momentary blackout of power supply system	Provide the rated voltage. Take measures such as checking or adding the UPS, power supply line filter and insulation transformer.
		Cable abnormalities (open circuit/not connected/short circuit)	Check the wiring of gas detector and related devices around it.
		Fuse disconnection	Find out why the fuse has blown and take appropriate actions before replacing it. If the power still cannot be turned on after replacement, the inside temperature fuse needs to be replaced. Please contact RIKEN KEIKI.
<u>Abnormal operations</u>	○	Disturbances by sudden surge noise, etc.	Turn off and restart the gas detector. If such a symptom is observed frequently, take appropriate measures to eliminate the noise.
<u>Incorrect flow rate indicator</u> (Specified Value Display does not correspond to 0.5 L/min.)	○	Improper flow rate default set	Seemingly performed an improper default set, i.e., performed a default set of flow rate on the gas detector when the flow rate is not 0.5 L/min. Prepare another flow meter and perform the flow rate default set again. <u>If such a symptom is observed frequently, the flow sensor is seemingly malfunctioning. Thus, it must be replaced. Please contact RIKEN KEIKI.</u>

Symptom/Display	FAULT	Causes	Actions
<u>Sensor unit abnormalities</u> E-1 SENSOR	•	The unit is not connected or improperly connected.	Check that the sensor unit is connected and the connectors of the unit are securely fastened.
		Errors in communication with the unit	Replace the sensor unit with a new one.
		Zero drift caused by environmental changes or aging deterioration is out of the range of zero follower.	Perform zero adjustment. If the symptom persists after the zero adjustment, replace the sensor unit with a new one.
		Faults of the unit itself	Check the sensor unit and replace it with a new one. If it is apparently damaged, do not touch it with bare hands and handle it carefully.
<u>Flow rate warning</u> FLOW	○	Unstable flow caused by deteriorated performance of the pump	Seemingly the pump is worn out and its performance is deteriorated. Although gas detection can be performed under this condition, the pump unit must be replaced as soon as possible.
		Unstable flow caused by clogged dust filter	Replace the dust filter.
		Unstable flow caused by bended or clogged suction tube or exhaust tube	Fix the defective parts.
		Pressure difference is present in the sampling condition. (The flow rate is ensured even though the pump drive level is low.)	In some sampling conditions (presence of pressure difference between IN and OUT), the flow rate is ensured even though the pump drive level is low. Although the gas detector can be used in such a situation, the diagnosis function of its pump drive level issues this message. The message can be eliminated by disabling this function. (See "7-2. Regular maintenance mode") Check the operating conditions before taking actions. * If the flow rate indicator is incorrect, the message may be displayed even though pressure difference is not present.
		Abnormalities are found in regular maintenance of the flow sensor.	Seemingly the performance of the flow sensor is deteriorated. In this case, the flow rate may not be in the range of 0.5 L/min \pm 10% even though the flow rate indicator indicates the specified value. Although gas can be detected provided that flow loss (fault alarm) does not occur, the flow sensor must be replaced to fix the symptom. Please contact RIKEN KEIKI.

9. Troubleshooting

Symptom/Display	FAULT	Causes	Actions
<u>Flow rate abnormalities</u> E-5 FLOW	●	Protective rubber cap is not removed.	Remove the protective rubber cap from GAS IN and GAS OUT.
		Broken pump	Replace the pump unit.
		Flow loss caused by clogged dust filter	Replace the dust filter.
		Flow loss caused by bended or clogged suction tube or exhaust tube	Fix the defective parts.
		The flow sensor is disconnected or improperly connected.	Please contact RIKEN KEIKI.
<u>Communication abnormalities</u> E-6 (ETHERNET)	○	Communication cable abnormalities	Check the wiring of gas detector and related devices around it.
		Disturbance by external noise	Turn off and restart the gas detector. If such a symptom is observed frequently, take appropriate measures to eliminate the noise.
<u>Clock abnormalities</u> E-9	○	Abnormalities of the clock inside the gas detector	Make a setting of Date/Time. Note that when the sensitivity correction function of ESU is used, correction may not be made properly. If such a symptom is observed repeatedly, the built-in clock is seemingly malfunctioning. Thus, it must be replaced. Please contact RIKEN KEIKI.
<u>System abnormalities</u> E-9 SYSTEM	●	The rated voltage is not supplied to the gas detector.	Check the power supply, and supply the rated voltage.
		Abnormalities of ROM, RAM or EEPROM of display unit	Please contact RIKEN KEIKI.
<u>Pyrolyzer abnormalities</u> E-7 PL UNIT	○	Pyrolyzer failure	Turn off and restart the gas detector. If the symptom does not improve, please contact RIKEN KEIKI.
		Cable abnormalities (open circuit/not connected/short circuit)	
		Abnormalities of ROM, RAM or EEPROM of pyrolyzer controller	
		Disturbance by external noise	Turn off and restart the gas detector. If such a symptom is observed frequently after the detection mode is activated, take appropriate measures to eliminate the noise.

<Abnormalities of Readings>

Symptoms	Causes	Actions
<u>The reading rises (drops) and it remains so.</u>	Drifting of sensor output	Perform zero adjustment.
	Presence of interference gas	Disturbances by interference gases, such as solvents, cannot be eliminated completely. For information on actions, such as removal filter, please contact RIKEN KEIKI.
	Slow leak	A very small amount of the gas to be detected may be leaking (slow leak). Because ignoring it may cause dangers, take a remedial measure, i.e., taking actions the same as those for the gas alarm.
	Environmental changes	Perform zero adjustment.
<u>A gas alarm is triggered despite of no gas leak and no other abnormalities at the detection point.</u>	Presence of interference gas	Disturbances by interference gases, such as solvents, cannot be eliminated completely. For information on actions, such as removal filter, please contact RIKEN KEIKI.
	Disturbance by noise	Turn off and restart the gas detector. If such a symptom is observed frequently, take appropriate measures to eliminate the noise.
	Sudden change in the environment	When the environment (temperature, etc.) changes suddenly, the gas detector cannot adjust to it and is affected by it. In some cases, the gas detector triggers an indication alarm. Because the gas detector cannot be used under sudden and frequent environmental changes, you must take any preventive actions to eliminate them.
<u>Slow response</u>	Clogged dust filter	Replace the dust filter.
	Bended or clogged suction tube or exhaust tube	Fix the defective parts.
	Condensation is formed inside the suction tube.	Fix the defective parts.
	Deteriorated sensor sensitivity	Replace the sensor unit with a new one.
<u>Span adjustment impossible</u>	Improper calibration gas concentration	Use the proper calibration gas.
	Deteriorated sensor sensitivity	Replace the sensor unit with a new one.

10

Product Specifications

10-1. List of specifications

<Product Specifications>

Model	TP-70DG II
Detection principle	Catalyst + electrochemical type
Gas to be detected	C4F6/C5F8/COS
Concentration display	Character LCD (Digital and Bar Meter Display)
Detection range	C4F6: 0 - 5 ppm/C5F8: 0 - 5 ppm/COS: 0 - 15 ppm
Detection method	Pump suction type/pyrolysis type
Flow rate	0.5 L/min \pm 10%
Alarm setpoint value	C4F6: 1st: 2 ppm, 2nd: 4 ppm/C5F8: 1st: 2 ppm, 2nd: 4 ppm/COS: 1st: 5 ppm, 2nd: 10 ppm
Power display	POWER lamp on (green)
Displays	Gas name display/flow rate indicator/mode display/communication status display/pyrolyzer connection display
External output	Gas concentration signal/gas alarm contact/fault alarm contact
Alarm accuracy (under the same conditions)	\pm 30% to the alarm setpoint value
Alarm delay time (under the same conditions)	Within 60 seconds after providing the gas 1.6 times the alarm setpoint (excluding delay in the tube)
Gas alarm type	Two-step alarm (H-HH)
Gas alarm display	First: ALM1 lamp blinks or lights up (Red)/Second: ALM2 lamp blinks or lights up (Red)
Gas alarm pattern	Auto-reset or self-latching
Gas alarm contact	No-voltage contact 1a or 1b (2 step independent) De-energized in a normal state (energized at an alarm state) or energized in a normal state (de-energized at an alarm state)
Fault alarm/self diagnosis	System abnormalities/sensor abnormalities/flow rate abnormalities/communication abnormalities/pyrolyzer abnormalities
Fault alarm display	FAULT lamp on (yellow)/detail display
Fault alarm pattern	Non latching (Auto-reset)
Fault alarm contact	No-voltage contact 1a or 1b De-energized in a normal state (energized at an alarm state) or energized in a normal state (de-energized at an alarm state)
Contact capacity	125 VAC, 0.25 A/24 VDC, 0.5 A (resistance load)
Contact cable	Cable of CVV, etc. (1.25sq) - max. 6-core
Functions	White backlight/alarm delay/suppression/zero follower/sensitivity correction/flow control Calibration history/alarm trend history/event history
Initial clear	Approx. 25 seconds
Tube connecting port	Rc1/4 (O.D 6-1t, half-union for Teflon tube <PP> supplied)
Operating temperature range	20 - 40°C
Operating humidities	40 - 70%RH (non-condensing)
Power consumption	150 VA or less

Structure	Tabletop type
External dimensions	Approx. 180 (W) x 225 (H) x 285 (D) mm (projection portions excluded)
Weight	Approx. 6.0 kg

<Specifications by Communication>

Model	(NT specification)	(EA specification) (EA (PoE) specification)
Transmission method	2-wire type DC power-line communication	Digital transmission: Ethernet (10BASE-T/100BASE-TX) Analog transmission: 3-wire type analog transmission (common cable for power and signal <power, signal, common>) or 2-wire type analog transmission
Transmission specification		Digital transmission: Ethernet Analog transmission: 4 - 20 mA DC (no-insulation/load resistance under 300 Ω)
Transmission cable	Shielded twisted-pair cable (1.25 sq) of KPEV-S, etc. - 1P	Digital transmission: Ethernet cable (category 5 or higher) Analog transmission: Shielded cable of CVVS, etc. (1.25 sq) - 3-core or 2-core
Power supply	100 - 240 VAC ±10% 24 VDC ±10% (Common with the transmission cable) (Dedicated line by blocking filter)	100 - 240 VAC ±10% or PoE connection (Common with the digital transmission cable for PoE connection)
CE marking	not supported	Supported*

* Please specify request when ordering.

10-2. List of accessories

- Operating Manual
- Protective rubber cap
- Dust filter
- Silica gel filter (supplied only when using the gas detector for C4F6/C5F8 detection)

10-3. Detection principle

A gas to be detected is passed through the pyrolyzer containing a catalyst to decompose it into a substance (HF or H₂S) which has high reaction activity to the electrochemical type sensor. The concentration of the target gas can be detected by detecting a gas generated after decomposition with the electrochemical type sensor.

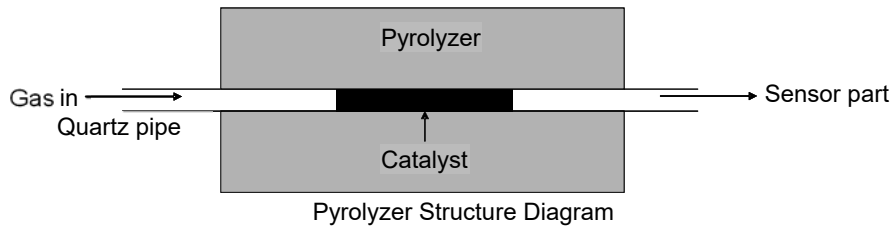
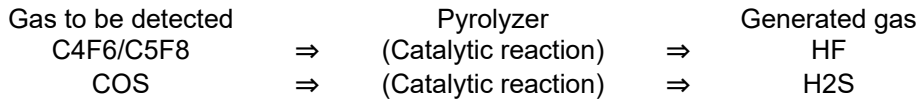

[Principle of electrochemical type sensor]

The electric potential between the working electrode and reference electrode is kept at a certain level by a potentiostat circuit.

The gas to be detected is electrolyzed directly at the working electrode. Because the electric current generated there is proportional to the gas concentration, the gas concentration can be known by measuring the electric current flow between the working electrode and the opposite electrode.

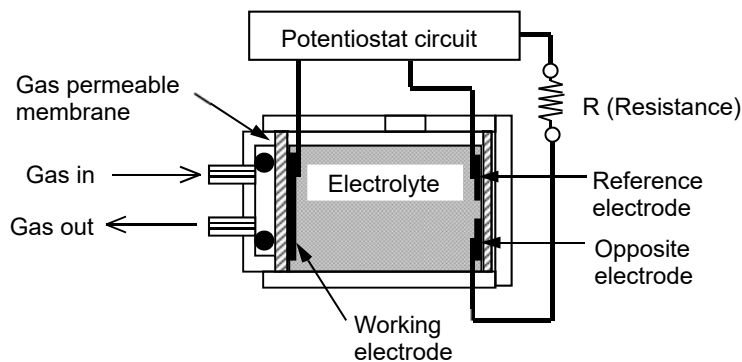

Sensor Part Structure Diagram

Special precautions for this principle

1. The gas detector may be interfered by gases other than the gas to be detected, solvents, vapors, etc. Please note that the alarm may be triggered by interference. In addition, it may be fluctuated by environmental (temperature, humidity, etc.) changes in the installation site.
2. The alarm must be set within a range where the performance of the gas detector can be ensured. In facilities compliant with the High Pressure Gas Safety Act, an alarm setting below our standard alarm setpoint (threshold limit value) may trigger a false alarm.
3. This is a safety unit, not a control unit.
The alarm contact output of the gas detector must be used for an external alarm lamp, while the analog signal output must be used for an indicator or external recorder. If these outputs are used to control other units, we shall not be responsible for any malfunctions.
4. Because the contact point of the gas detector sensor is made of porous polymeric membrane, the water repellency of the membrane is deteriorated by solvents, thus causing an electrolyte leak from its inside. Do not use solvents near the gas detector. If a solvent is used for unavoidable reasons, attach the recommended filter to the areas such as inlet of the gas detector while using the solvent and for one hour after that.
5. For maintenance of the gas detector, it must go through a regular maintenance, including replacement and adjustment of the regular replacement parts as specified in the operating manual. In addition, because this is a safety unit, it is recommended that a regular maintenance and a calibration are performed every six months in accordance with the regulations.

Definition of Terms

External dust filter	When the gas detector is used in a dusty environment, it is recommended that a dust filter should be attached to its outside. The filter is specified based on the gas to be detected. Please contact RIKEN KEIKI.
vol%	Gas concentration indicated in the unit of one-hundredth of the volume
ppm	Gas concentration indicated in the unit of one-millionth of the volume
ppb	Gas concentration indicated in the unit of one-billionth of the volume
Calibration	Find relationship of the readings, display values or setting values with the actual values by using the calibration gas.
Maintenance mode	When maintenance is performed on the gas detector, the alarm contact is disconnected, and a signal to indicate the maintenance mode status is sent out to the external output signal. As a result, maintenance can be performed on a single unit of the gas detector.
Initial clear	The reading is unstable for seconds after the power is turned on. To prevent malfunctions for that period, the alarm contact is deactivated. In addition, a signal to indicate the initial clear status is sent out to the external output.
Zero suppression	A function to cut off the influences of environmental changes, interference gases, etc.
Alarm delay time	A function which temporarily suspends activation to prevent a false alarm caused by noise from its outside.
Inhibit	The gas detection function is temporarily suspended during maintenance, etc. of the gas detector. This is also called "point skip", which has the same function.
Pyrolyzer	A unit to decompose gases under high temperatures. It pyrolyzes special gases under high temperature to make them detectable.



EU-Declaration of Conformity

Document No.: 320CE22109



We, RIKEN KEIKI Co., Ltd. 2-7-6, Azusawa, Itabashi-ku, Tokyo, 174-8744 Japan declare under our sole responsibility that the following product conforms to all the relevant provisions.

Product Name: Gas Detector
Model: TP-70DGI

Council Directives		Applicable Standards
2014/35/EU	LVD Directive	EN 61010-1:2010+A1:2019
2014/30/EU	EMC Directive	EN 50270:2015
2011/65/EU ^[1]	RoHS Directive	EN IEC 63000:2018

^[1]Including substances added by Commission Delegated Directive (EU) 2015/863

Place: Tokyo, Japan

Date: Jun. 29, 2022

Takakura Toshiyuki
General manager
Quality Control Center



UK-Declaration of Conformity

Document No.: 320UK22025



We, RIKEN KEIKI Co., Ltd. 2-7-6, Azusawa, Itabashi-ku, Tokyo, 174-8744 Japan declare under our sole responsibility that the following product conforms to all the relevant provisions.

Product Name: Gas Detector
Model: TP-70DGII

Regulations	UK designated Standards
Electromagnetic Compatibility Regulations 2016 (S.I. 2016/1091)	BS EN 50270:2015
The Restriction of the Use of Certain Hazardous Substances in Electrical and Electronic Equipment Regulations 2012 (S.I. 2012/3032)	BS EN IEC 63000:2018
The Electrical Equipment (Safety) Regulations 2016 (S.I. 2016/1101)	BS EN 61010-1:2010 +A1:2019

Place: Tokyo, Japan

Date: May. 27, 2022

Takakura Toshiyuki
General manager
Quality Control Center