



Smart Transmitter/Gas Detector Head

SD-1EC (TYPE HS)

Operating Manual

(PT2E-176)

(PT2-176)

RIKEN KEIKI Co., Ltd.

2-7-6 Azusawa, Itabashi-ku, Tokyo, 174-8744, Japan

Phone : +81-3-3966-1113

Fax : +81-3-3558-9110

E-mail : intdept@rikenkeiki.co.jp

Web site : <https://www.rikenkeiki.co.jp/english/>

Operating Precautions

This detector is a gas detector that detects toxic gases in the air and triggers a gas alarm.

The gas detector is a safety unit, not an analyzer or densitometer which performs quantitative/qualitative analysis/measurement for gases.

Please fully understand the following points before using it, so that it can be used properly.

1. The detector may be interfered by gases other than the gas to be detected, solvents, vapors etc. Please note that the alarm may be triggered by interference. In addition, it may be fluctuated by environmental (temperature, humidity etc.) changes in the installation site.
2. The alarm must be set within a range where the performance of the detector can be ensured. In facilities compliant with the High Pressure Gas Safety Act, an alarm setting below our standard alarm setpoint (threshold limit value) may trigger a false alarm.
3. If use in safety unit, the analog signal output of the detector must be used for an indicator or external recorder.
If these outputs are used to control other units, we shall not be responsible for any malfunctions.
If use as safety instrumentation device, determine the specification and manage it based on the safety manual.
4. Because the contact point of the gas detector sensor is made of porous polymeric membrane, the water repellency of the membrane is deteriorated by solvents, thus causing an electrolyte leak from its inside. Do not use solvents near the detector. If a solvent is used for unavoidable reasons, attach the recommended filter to the inlet of the gas detector while using the solvent and for one hour after that.
5. For maintenance of the detector, it must go through a regular maintenance, including replacement and adjustment of the regular replacement parts as specified in the operating manual. In addition, because this is a safety unit, it is recommended that a regular maintenance and a calibration are performed every six months in accordance with the regulations.
6. This detector is SIL2 certified for single application. SIL 2 is Safety Integrity Level by safety instrumentation functioning omni-PFD avg .If use as safety instrumentation device, determine the specification and manage it based on the safety manual.

<Contents>

1 Outline of the Product.....	2
1-1. Preface.....	2
1-2. Purpose of use.....	2
1-3. Definition of DANGER, WARNING, CAUTION and NOTE.....	2
1-4. Method of confirmation for Standards and Explosion proof.....	3
2 Important Notices on Safety.....	4
2-1. Danger cases.....	4
2-2. Warning cases.....	5
2-3. Precautions.....	6
2-4. Safety Information.....	7
3 Product Components.....	9
3-1. Main unit and standard accessories.....	9
3-2. Names and functions for each part.....	10
3-3. Block diagram.....	11
4 How to Use.....	12
4-1. Before using the gas detector.....	12
4-2. Precautions for installation sites.....	12
4-3. Precautions for system designing.....	13
4-4. How to install.....	14
4-5. Installation procedure.....	16
4-6. How to wire.....	18
5 How to Operate.....	22
5-1. Preparation for start-up.....	22
5-2. Basic operating procedures.....	22
5-3. How to start the gas detector.....	23
5-4. Modes.....	24
5-5. User mode.....	25
5-6. How to exit.....	27
6 Operations and Functions.....	28
6-1. Gas alarm activation.....	28
6-2. Fault alarm activation.....	29
6-3. Warning activation.....	29
6-4. External output operation.....	30
6-5. Other functions.....	31
7 Maintenance.....	32
7-1. Maintenance intervals and items.....	32
7-2. Proof test.....	33
7-3. Parts replacement.....	34
8 Storage, Relocation and Disposal.....	35
8-1. Procedures to store the gas detector or leave it for a long time.....	35
8-2. Procedures to relocate the detector or use it again.....	35
8-3. Product disposal.....	35
9 Troubleshooting.....	37
10 Product Specifications.....	39
10-1. List of specifications.....	39
10-2. Detection principle.....	43
11 Definition of Terms.....	44

1

Outline of the Product

1-1. Preface

Thank you for choosing our smart transmitter/gas detector head SD-1EC(TYPE HS). Please check that the model number of the product you purchased is included in the specifications on this manual.

This manual explains how to use the detector and its specifications. It contains information required for using the gas detector properly. Not only the first-time users but also the users who have already used the product must read and understand the operating manual to enhance the knowledge and experience before using the detector.

Product specifications may be abbreviated in this document as follows.



Japan Ex specification : Japan specification

ATEX / IECEx specification : Export specification

1-2. Purpose of use

- This detector is a fixed type gas detector head that detects leak of toxic gases and performs the alarm activation when the gas concentration is over the setting value.
- The detector is a safety unit, not an analyzer or densitometer which performs quantitative/qualitative analysis/measurement for gases. Please fully understand the features of the detector before using it, so that it can be used properly.
- The detector detects abnormalities in the air caused by presence of gases or other reasons (leak) with the built-in gas sensor. The concentrations of detected gases are displayed on the seven-segment LED.
- The detector outputs gas concentration in 4 – 20 mA.
- The detector has HART communication function.

1-3. Definition of DANGER, WARNING, CAUTION and NOTE

 DANGER	This message indicates that improper handling may cause serious damage on life, health or assets.
 WARNING	This message indicates that improper handling may cause serious damage on health or assets.
 CAUTION	This message indicates that improper handling may cause minor damage on health or assets.
NOTE	This message indicates advice on handling.

1-4. Method of confirmation for Standards and Explosion proof

The product specifications will vary depending on the specific standards and explosion-proof certification. Check the actual product specifications before use. You can confirm instrument specification to see name plate as follows.

Ex mark

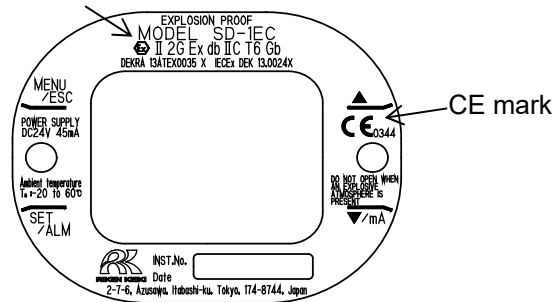

ATEX/IECEx, CE marking type name plate

Japan Ex certificate

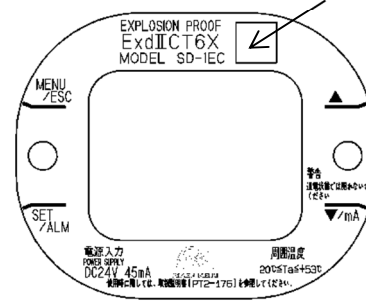

Japan Ex type name plate

2

Important Notices on Safety

2-1. Danger cases



DANGER

About explosion-proof

- The window plate material is a polycarbonate resin. Do not use organic solvents and alkali types (liquid or vapor). It may cause the color and shape of the window plate to be changed.
- Do not open the lid when applying current.
- Do not attempt to repair the detector.
- For the lid, use hexagon socket head bolts specified by RIKEN KEIKI.
- Do not apply a strong force or shock to the window plate. The explosion-proof performances may be deteriorated due to damages. The explosion protection condition for the detector is "low (2J)" possibility of mechanical damage.
- Ambient temperature:
Export Specification: -20 to 60°C
Japan Specification: -20 to 53°C
(The ambient temperature on explosion-proof certification is described above and it indicates the temperature range which can maintain the explosion-proof performance and not the product performance, see "10-1. List of specifications" for details.)
- Do not replace parts at your sole discretion but contact RIKEN KEIKI if the transparent window has a crack or the explosion-proof joint surface is abnormal, or the clamping screw or bolt is changed, lost etc.
- Do not repair the explosion-proof joint surface.
- Be careful not to hit sharp tools against the window plate.

2-2. Warning cases



WARNING

Power supply

Before turning on the detector, always check that the voltage is properly applied. Do not use an unstable power supply because it may cause malfunctions.

Need of grounding circuit

Do not cut the grounding circuit or disconnect the wire from the grounding terminal.

Defects in protective functions

Before starting the detector, check the protective functions for defects. When seeming defects are found in the protective functions, such as protective grounding, do not start the detector.

External connection

Before connecting the detector to the external control circuit, securely connect it to a protective grounding circuit.

Zero adjustment in the atmosphere

When the zero adjustment is performed in the atmosphere, check the atmosphere for freshness before beginning the adjustment. If interference gases exist, the adjustment cannot be performed properly, thus leading to dangers when the gas leaks.

Response to gas alarm

Issuance of a gas alarm indicates that there are extreme dangers. Take proper actions based on your judgment.

Handling of sensor

Do not disassemble the sensor used by the detector because it contains electrolyte. Electrolyte may cause severe skin burns if it contacts skin, while it may cause blindness if its contacts eyes. If electrolyte is adhered on your clothes, that part on your clothes is discolored or its material is decomposed. If contact occurs, rinse the area immediately with a large quantity of water.

2-3. Precautions



CAUTION

Do not use a transceiver near the detector.

Radio wave from a transceiver or other radio wave transmitting device near the detector or its cables may disturb readings. If a transceiver or other radio wave transmitting device is used, it must be used in a place where it disturbs nothing.

To restart the detector, wait for five seconds or more before doing it.

Restarting the detector in less than five seconds may cause errors.

Do not use the external output of the detector to control other units.

This is not a control unit. It is not allowed to use the external output of the detector to control other units.

Do not disassemble/modify the detector, or change the settings if not necessary.

Disassembling/modifying the detector will invalidate the warranty of the performance. Changing the settings without understanding the specifications may cause alarm malfunctions. Please use the detector properly in accordance with the operating manual.

Avoid applying organic solvents and others to the window plate for a long time.

The window plate material is a polycarbonate resin. When organic solvents (liquid or highly-concentrated vapor) and others are applied to the plate for a long time, its color and shape may be changed.

Never fail to perform a regular maintenance.

Since this is a safety unit, a regular maintenance must be performed to ensure safety. Continuing to use the detector without performing a maintenance will deteriorate the sensitivity of the sensor, thus resulting in inaccurate gas detection.

2-4. Safety Information

Necessary information for explosion proof construction of Model SD-1EC.

The Model SD-1EC is a fixed mount, continuous-monitoring detector head and provides a 4-20mA signal which indicates the target gas reading for use by a gas monitoring controller, recording device, or programmable controller.

<ATEX/IECEX Specification>

Technical Data

(Protection Method)	Flameproof enclosure “d”
(Certificate Numbers)	IECEX DEK 13.0024X DEKRA 13ATEX0035 X
(Group)	II
(Category)	2 G
(Type of Protection and Marking code)	Ex db IIC T6
(Equipment Protection Level)	Gb
(Ambient Temperature)*	-20°C to +60°C
(Electrical Data)	Supply voltage: DC24 V 45mA Output signal (4 to 20 mA): DC24V 22mA
(Applicable Standard)	IEC 60079-0: 2017, IEC 60079-1: 2014-06 EN IEC 60079-0: 2018, EN 60079-1: 2014
(Manual Number)	PT2E-176

* The ambient temperature on explosion-proof certification is described above and it indicates the temperature range which can maintain the explosion-proof performance and not the product performance, see “10. Product specifications” for details.

Installation

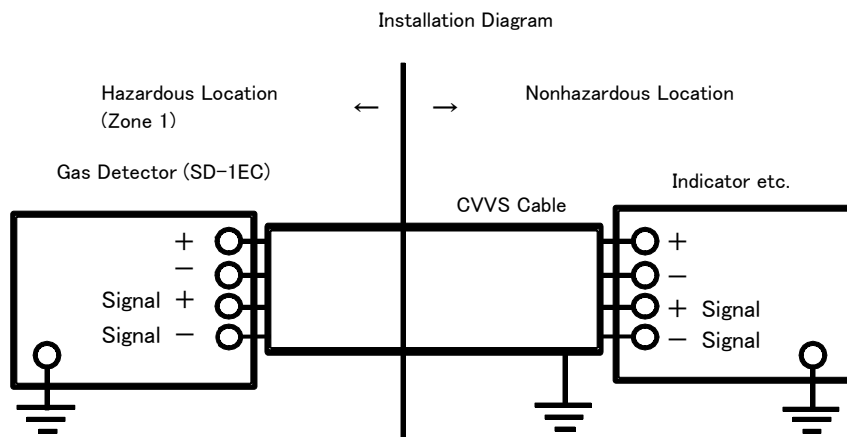

<Japan Ex Specification>

Technical Data

(Protection Method)	Flameproof enclosure
(Explosion-proof class)	Ex d IIC T6 X
(Ambient Temperature)*	-20°C to +53°C
(Electrical Data)	Supply voltage: DC24V 45mA
	Detecting element output signal: DC0.5V 0.5mA
	Analog signal output: DC24V 22mA
(Applicable Standard)	JNIOSH-TR-NO. 43(2008)

* The ambient temperature on explosion-proof certification is described above and it indicates the temperature range which can maintain the explosion-proof performance and not the product performance, see “10. Product specifications” for details.

Installation

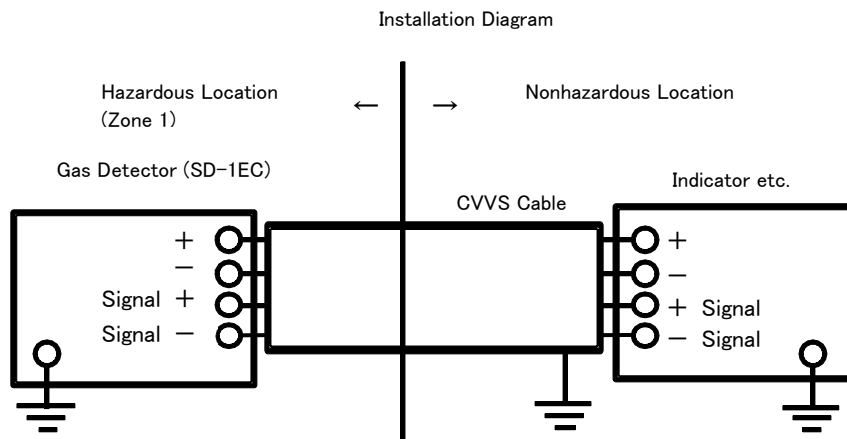

3

Product Components

3-1. Main unit and standard accessories

<Main Unit> (including a cable gland or an adapter)
 【Export Specification】

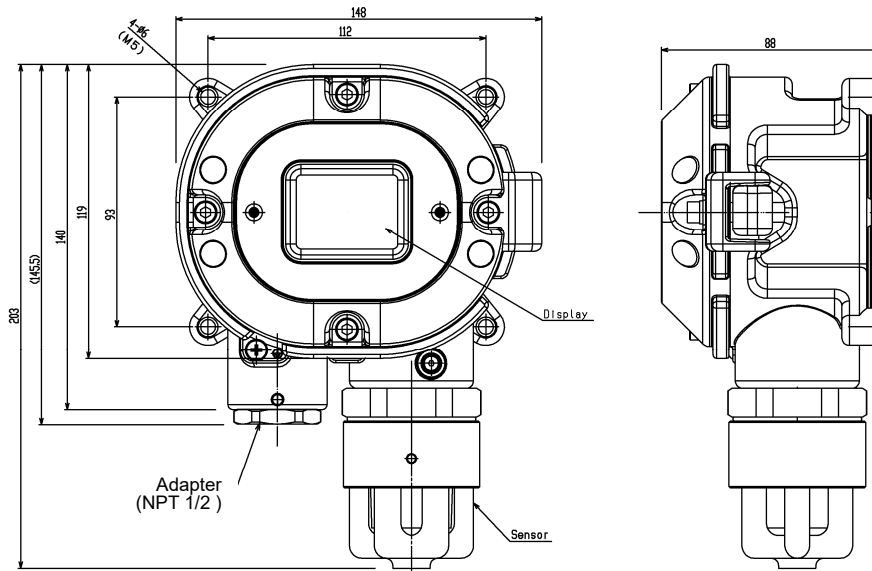

【Japan Specification】

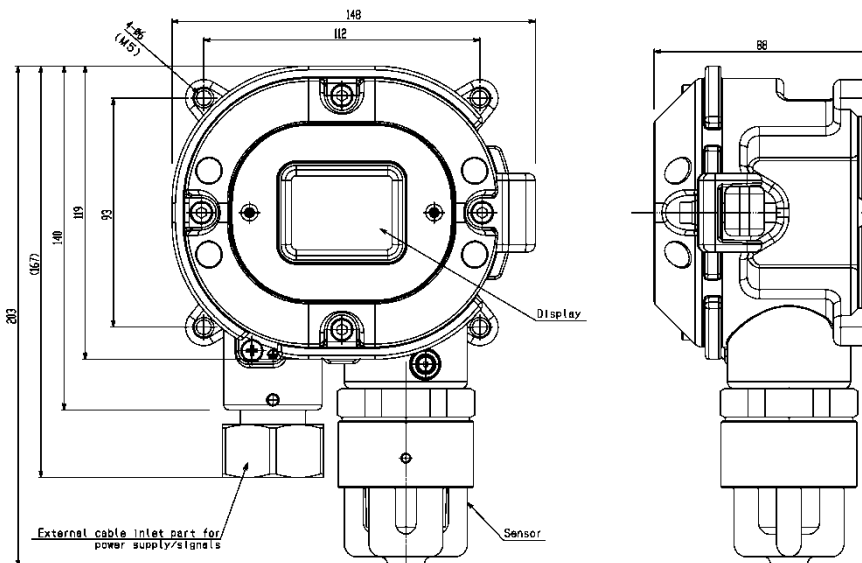

<Standard Accessories>

- Operating manual
- Safety manual
- Dedicated handling lever (used for the wiring)
- Dedicated control key

**CAUTION**

Use the supplied dedicated control key to operate the detector. If products other than these accessories are used, key operations cannot be accepted properly.

Note that the control key is made of extremely strong magnet. Putting it close to a magnetic product, such as a credit card and ID card, may damage the stored data.

3-2. Names and functions for each part

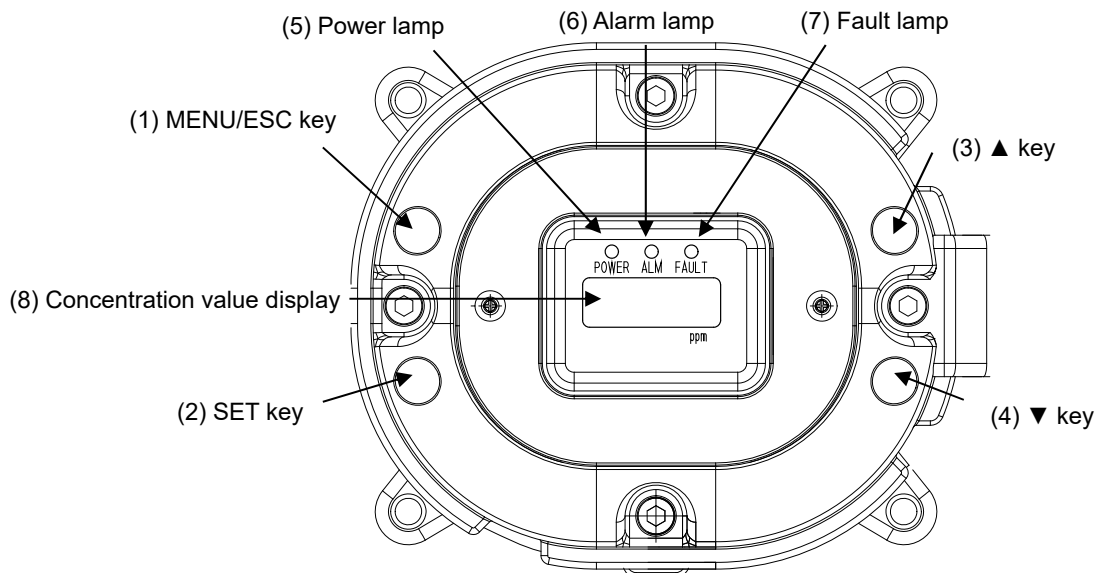

(1)	MENU/ESC key	Used to enter the maintenance mode. It is also used to cancel in a specific mode.
(2)	SET key	It is used for value confirmation and so on in a specific mode.
(3)	▲ key	Used to switch menus or change a value (UP).
(4)	▼ key	Used to switch menus or change a value (DOWN).
(5)	Power lamp	Power lamp. Detection mode: It lights up in green. Maintenance mode: It blinks in green.
(6)	Alarm lamp	Alarm lamp. It lights up in red when the alarm setpoint value is reached.
(7)	Fault lamp	Fault lamp. It lights up in yellow when an abnormality is detected in the detector.
(8)	Concentration value display	Display the gas concentration and so on.

3-3. Block diagram

<Electric Diagram>

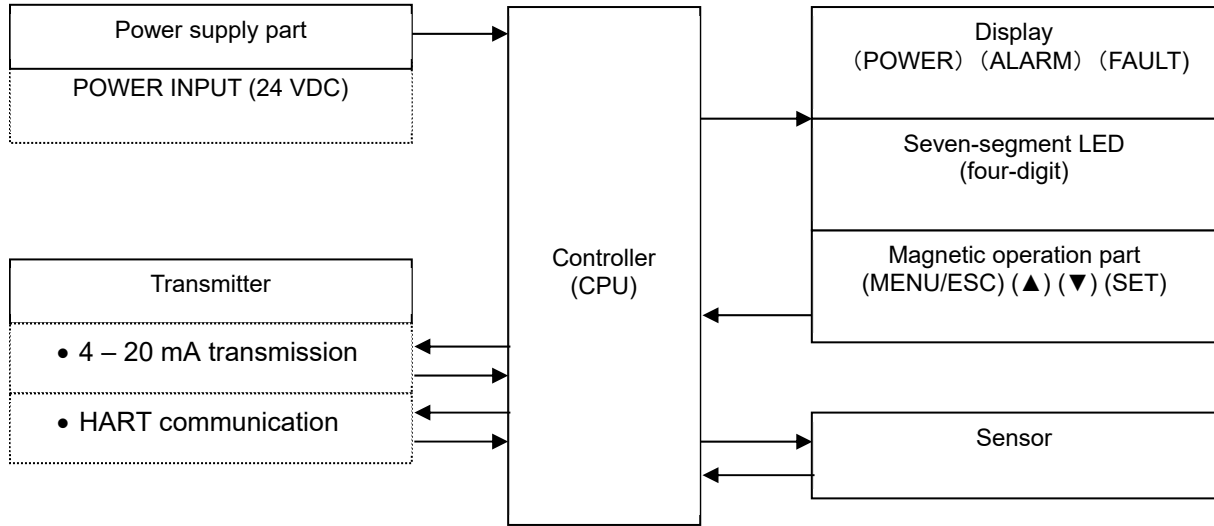

4

How to Use

4-1. Before using the gas detector

Not only the first-time users but also the users who have already used the detector must follow the operating precautions.

Ignoring the precautions may damage the gas detector, resulting in inaccurate gas detection.

4-2. Precautions for installation sites



CAUTION

This is a precision device. Because the detector may not provide the specified performance in some places (environments), check the environment in the installation point, and then take appropriate actions if necessary.

Because the detector plays an important role for safety and disaster prevention, as many units of the detector as needed must be installed in appropriate points.

Because points where gases leak and remain easily are different depending on the types of gases and the working areas, please decide carefully on installation points and the number of units to be installed.

Do not install the detector in a place with vibrations or shocks.

The detector consists of sensitive electronic parts. The detector must be installed in a stable place without vibrations or shocks and it cannot drop.

Do not install the detector in a place exposed to water, oil or chemicals.

When selecting installation points, avoid a place where the detector is exposed to water, oil or chemicals.

Do not install the detector in a place where the range of operating temperatures is exceeded.

The detector must be installed in a stable place where the operating temperature is maintained and does not change suddenly.

<Export Specification> -10 to +40°C

<Japan Specification> -10 to +40°C

Do not install the detector in a place exposed to direct sunlight or sudden changes in the temperature.

When selecting installation points, avoid a place where it is exposed to direct sunlight or radiant heat (infrared rays emitted from a high-temperature object), and where the temperature changes suddenly. Condensation may be formed inside the detector, or the detector cannot adjust to sudden changes in the temperature.

Keep the detector (and its cables) away from noise source devices.

When selecting installation points, avoid a place where high-frequency/high-voltage devices exist.

Do not install the detector in a place where maintenance of the detector cannot be performed or where handling the detector involves dangers.

Regular maintenance of the detector must be performed.

Do not install the detector in a place where the machinery must be stopped when maintenance is performed in its inside, where parts of the machinery must be removed to perform maintenance, or where the detector cannot be removed because tubes or racks prevent access to it. Do not install the detector in a place where maintenance involves dangers, for example, near a high-voltage cable.

Do not install the detector in machinery which is not properly grounded.

Before installing the detector in machinery, the machinery must be grounded properly.

Do not install the detector in a place where interference gases exist around it.

The detector must not be installed in a place where interference gases exist around it.

4-3. Precautions for system designing



CAUTION

An unstable power supply and noise may cause malfunctions or false alarms. The descriptions in this section must be reflected on the designing of a system using the detector.

Using a stable power supply

The external output of the detector may be activated when the power is turned on, when momentary blackout occurs, or while the system is being stabilized. In such cases, use a UPS (uninterruptible power supply), or take appropriate actions on the receiving side.

The detector must be provided with the following power supply.

Power supply voltage	24 VDC±10%: Terminal voltage of the detector	
Allowed time of momentary blackout	Up to 10 milliseconds (To recover from the momentary blackout for 10 milliseconds or more, restart the detector.)	<u>Example of actions</u> To ensure continuous operation and activation, install a UPS outside the detector.
Others	Do not use it with a power supply of large power load or high-frequency noise.	<u>Example of actions</u> Use a line filter to avoid the noise source if necessary.

Introducing protective measures against lightning

If cables are installed outside the factory/plant, or if internal cables are installed in the same duct as the cables coming from outside the factory/plant, "lightning" will cause problems. Because lightning acts as a large emission source while cables act as a receiving antenna, devices connected to the cables may be damaged.

Lightning cannot be prevented. Cables installed in a metal conduit or under the ground cannot be completely protected from inductive lightning surge caused by lightning. Although complete elimination of disasters caused by lightning is impossible, the following protective measures can be taken.

Protection against lightning	<p><u>Take appropriate measures in accordance with the importance of the facilities and the environment.</u></p> <ul style="list-style-type: none"> Provide protection by a lightning arrester (cable arrester). (Although inductive lightning surge can be transmitted through the cable, it is prevented by installing a lightning arrester before the field devices and central processing equipment. For information on how to use a lightning arrester, please contact the manufacturer.)
Grounding	In addition to lightning, there are more sources of surge noise. To protect units from these noise sources, the units must be grounded.

* The lightning arrester has a circuit to remove a surge voltage which damages field devices, so that signals may be attenuated. Before installing a lightning arrester, verify that it works properly.

4-4. How to install

<Installation Dimensions and Maintenance Space>

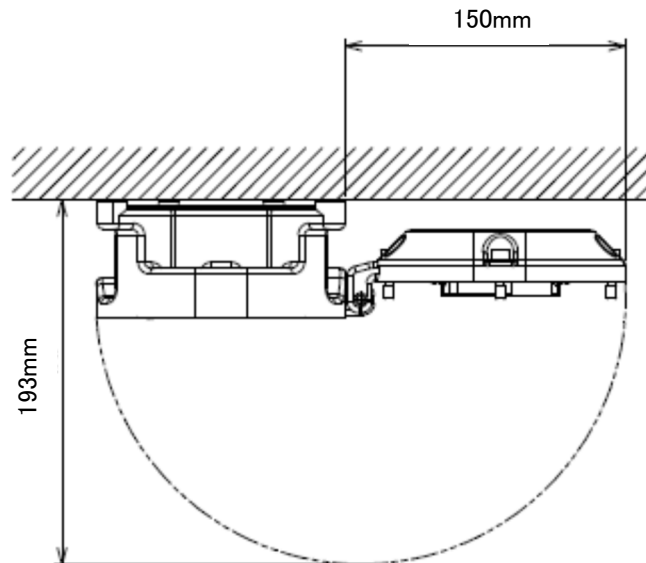

The following installation requirements must be met to install the detector.

- Attach the detector on the wall and others using four M5 screws.
- Tighten the hexagon socket head cap bolt fixing the lid and the main body with a tightening torque of $215.6 \pm 24.5 \text{ N} \cdot \text{cm}$.
- When closing the lid of the detector, make sure that there is no dust on screw, surfaces of the main body and lid. Then apply grease as specified by RIKEN KEIKI.



CAUTION

Do not install the detector in a place where maintenance of the detector cannot be performed or where handling the detector involves dangers.

Regular maintenance of the detector must be performed.

Do not install the detector in a place where the machinery must be stopped when maintenance is performed in its inside, where parts of the machinery must be removed to perform maintenance, or where the detector cannot be removed because tubes or racks prevent access to it. Do not install the detector in a place where maintenance involves dangers, for example, near a high-voltage cable.



WARNING

- Install the detector head in the specified direction. Installing it in a wrong direction may cause abnormal readings.
- Do not install the detector in a damp place where condensation occurs. Water drops formed on the sensor may cause abnormal detection.

Detector head installation direction

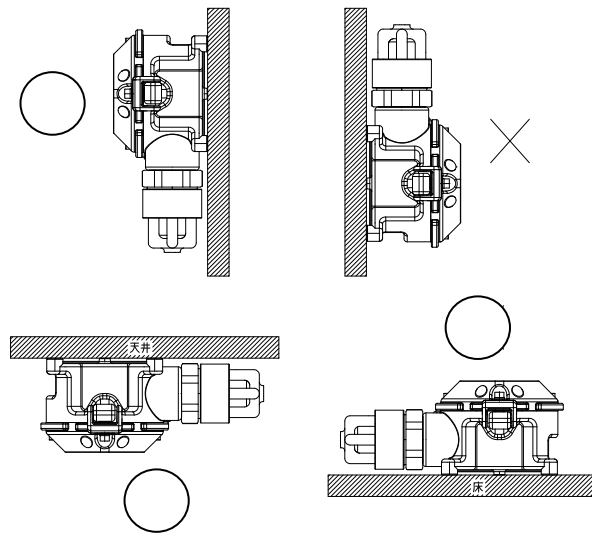
**NOTE**

- Hexagon socket head cap bolt with strength class "A2-70" are used.
When you lost or replace it, we recommend that you ask our local sales office nearest you.
- Grease specified by RIKEN KEIKI : BARRIERTA JFE 552 (manufactured by NOK KLUBER)
If you can not prepare the specified grease, use one that meets the following requirements.
 1. Material does not harden due to deterioration
 2. Volatile solvent-free
 3. Material does not cause corrosion at the surface
 4. Silicon-free
 5. Validation of suitability depends on the specifications of grease manufacturer

4-5. Installation procedure

<Attaching External Cable>

【Export Specification】

The export specification comes with adapter A (NPT 1/2) as standard. Please prepare the Ex cable gland that is suitable for the adapter.

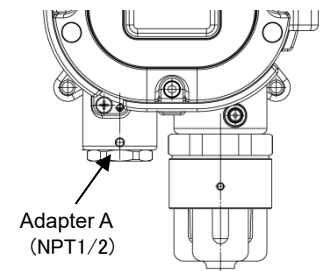

【Japan Specification】

Cable gland, Rubber seal, Washer and Eccentric washer are mounted on SD-1EC main body as shown below.

Attach the parts :

Pass a Cable (e.g. CVVS) through the Cable gland, Eccentric washer, Washer, and Rubber seal, and drawn into detector inside. (For wire methods, see "4-6 How to wire".) When installing the cable gland, make sure that there is no dust in cable gland mounting part, hexagon socket set screw, grounding screw, and the cable gland. Then apply grease specified by RIKEN KEIKI.

Tightens Cable gland, and then tightens hexagon socket set screw (M4×6), and fix cable gland.

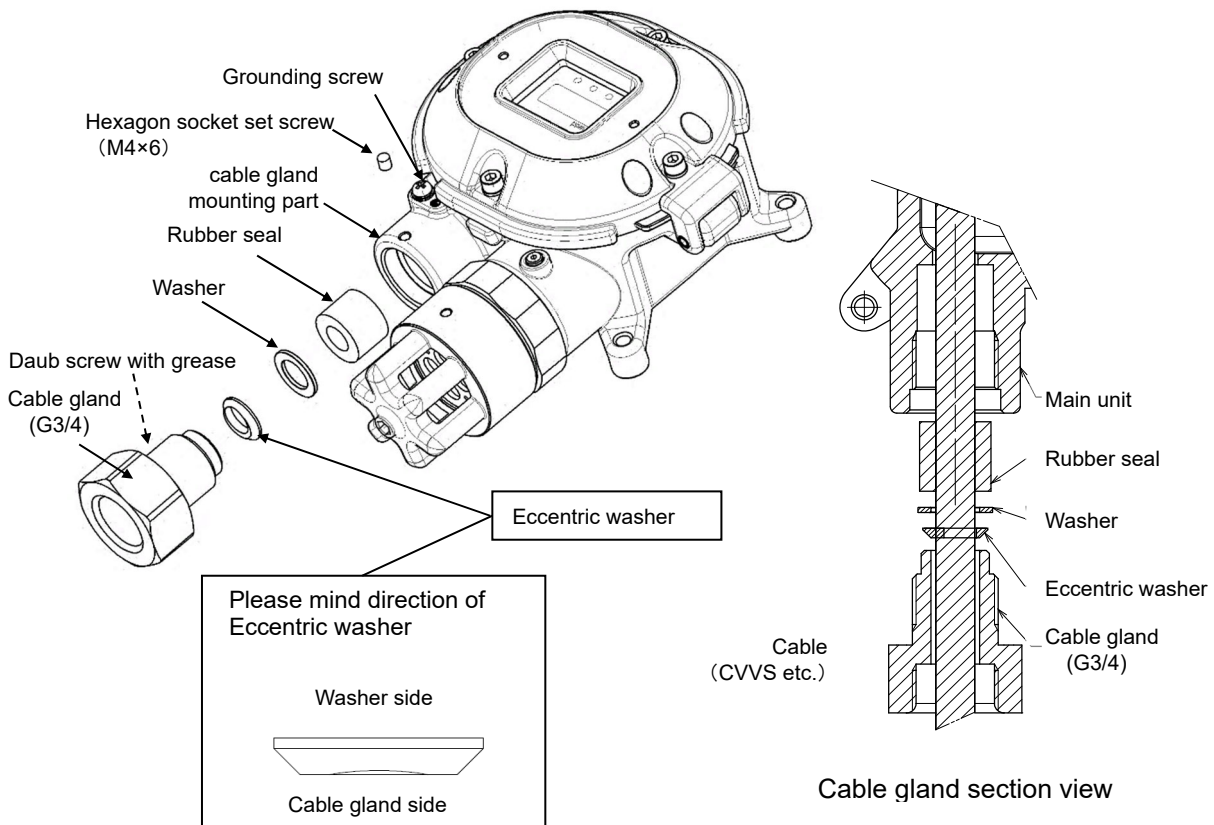

**WARNING**

- Do not replace parts at your sole discretion but contact RIKEN KEIKI if the transparent window has a crack or the explosion-proof joint surface is abnormal, or the clamping screw or bolt is changed, lost etc.

**CAUTION**

- Tighten 40 N·m or larger torque value to ensure the tightening cable gland and seal plug.
- Tighten the hexagon socket head cap screws fixing the cable gland with a tightening torque of $107.8 \pm 12.7 \text{ N}\cdot\text{m}$.

NOTE

- Our company-specified grease : BARRIERTA JFE 552 (manufactured by NOK KLUBER)
If you can not prepare the specified grease, use one that meets the following requirements.
 1. Material does not harden due to deterioration
 2. Volatile solvent-free
 3. Material does not cause corrosion at the surface
 4. Silicon-free
 5. Validation of suitability depends on the specifications of grease manufacturer

4-6. How to wire



CAUTION

- Be careful not to damage the internal electronic circuit when wiring. In addition, be careful not to apply stresses on the detector when (overweight) cables are installed.
- The power cables and signal cables must not be installed together with the motor power cables etc. When these cables must be installed together for unavoidable reasons, put the power cables and signal cables in a metal conduit. The conduit must be connected to a grounding circuit.
- When stranded wires are used, prevent wires from contacting each other.
- Use the dedicated handling lever to wire.
- Use appropriate cables to wire.

<Recommended Cables>

3-wire	CVVS 1.25 mm ² or 2.0 mm ² /3-core
4-wire	CVVS 1.25 mm ² or 2.0 mm ² /4-core

<Parts. length table of outside conductor lead-in>(Japan Specification)

Cable overall outer diameter(mm)	Rubber seal inner diameter(mm)	Washer inner diameter(mm)	Clamp inner diameter(mm)
From $\Phi 9.6$ to $\Phi 10.5$	$\Phi 11$	$\Phi 12$	$\Phi 10.8$
From $\Phi 10.5$ to $\Phi 11.5$	$\Phi 12$	$\Phi 12$	$\Phi 11.8$
From $\Phi 11.5$ to $\Phi 12.5$	$\Phi 13$	$\Phi 14$	$\Phi 12.8$
From $\Phi 12.5$ to $\Phi 13.0$	$\Phi 13.5$	$\Phi 14$	$\Phi 13.8$

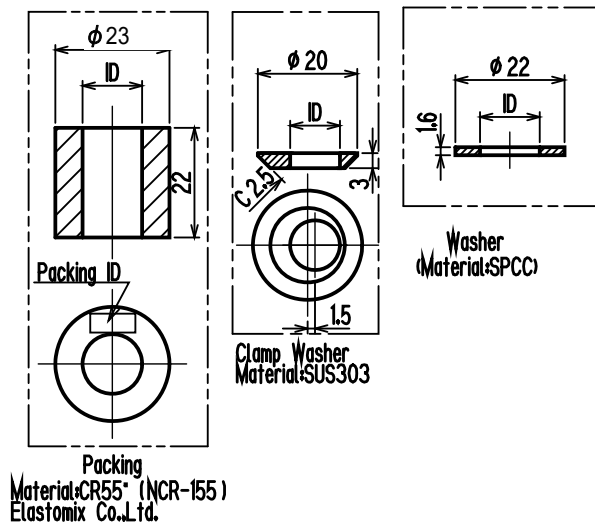

NOTE

- The following table shows an example of overall outer diameters of cables. Use them for reference. The overall outer diameters must be checked because they somewhat vary between manufacturers.

Number of core	CVV 1.25 mm ²	CVV 2 mm ²	CVVS 1.25 mm ²	CVVS mm ²
2	$\phi 9.5$	$\phi 10.5$	$\phi 10.0$	$\phi 11.0$
3	$\phi 10.0$	$\phi 11.0$	$\phi 10.5$	$\phi 11.5$
4	$\phi 10.5$	$\phi 11.5$	$\phi 11.0$	$\phi 12.0$
5	$\phi 11.5$	$\phi 12.5$	$\phi 12.0$	$\phi 13.0$
6	$\phi 12.5$	$\phi 13.5$	$\phi 13.0$	$\phi 14.0$

<Figure of Terminal Plate>

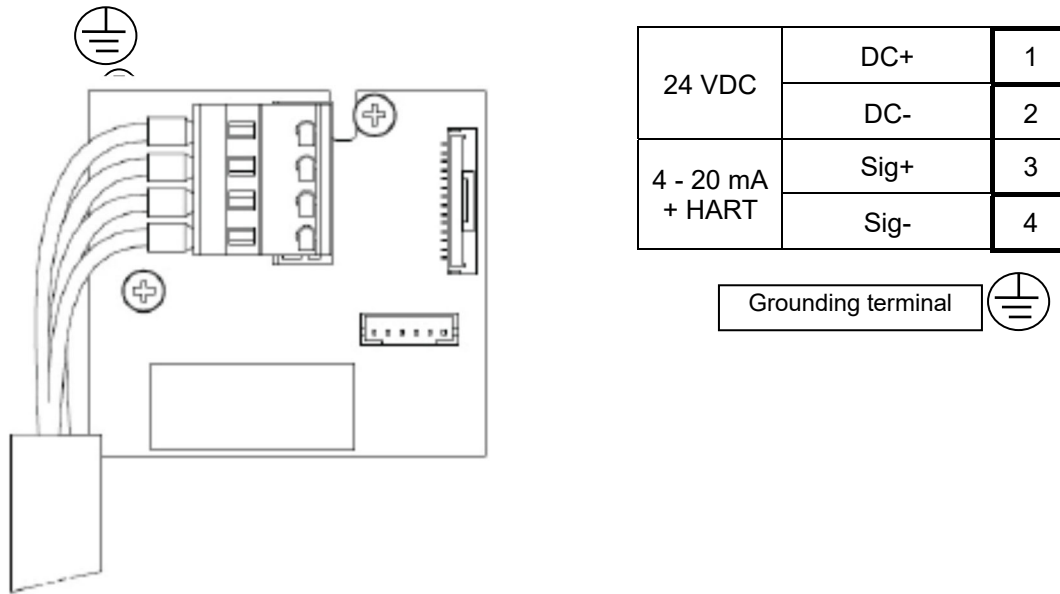

<Specifications of Terminal Plate>

Specifications of terminal plate

- Rated voltage: 250 VAC
- Rated current: 12 A
However, it depends on cables to be used.

Connection conditions

- Cables: 0.25 - 2.5 mm²
- Bare wire length: 8 - 9 mm
- Connecting tool: Dedicated handling lever (accessory) or driver (edge 3.5 x 0.5 mm)

<When 4-20mA output is not used>

This detector has a self-diagnosis function which shows E-9 on LED display when 4-20mA is not properly outputted.

If 4-20mA output is not necessary, connect the following fixed resistance (lead type) to the terminal 2 and 3 ("Sig+" and "-(common)").

Resistance value : 100-300Ω Rated power : 0.25W or more

Insert a cable and the above resistance together into Terminal 2 (common), and insert lead part of the resistance into terminal 3 (Sig+). After that, check the immovability.



CAUTION

The specified bare wire length must be observed when the wire insulation is peeled off. Improper clamping of the wire due to a shorter bare wire length may cause defective electric conduction or heating. Catching the wire insulation due to a shorter bare wire length may cause defective electric conduction or heating. Exposing the wire due to a longer bare wire length may cause defective insulation or a short circuit. Be careful not to break up the wire. If the wire is broken up when inserted to the terminal, this may cause defective insulation or heating.



Compatible bar terminal

For a bar terminal, the following items are available.

- Bar terminal (ferrule): Model 216 Series (manufactured by WAGO)
- Crimping tool: Model VarioCrimp 4 (206-204) (manufactured by WAGO)



CAUTION

A bar terminal of the specified model must be used. Using other bar terminals invalidates the warranty of the performance.

< How to Connect to Terminal Plate >

When cables are connected to the connectors, use the dedicated lever or a flathead screwdriver to do it as shown below.



CAUTION

The right tools must be used. In principle, one wire can be connected to one wiring hole. When the wire is inserted into the driver slot by mistake, it does not contact the conductive part. This may cause defective electric conduction or heating. When the wire is inserted under the spring by mistake, it does not contact the conductive part. This may cause defective electric conduction or heating.

NOTE

<How to Use the Dedicated Handling Lever>



Push the lever with your finger to lower the spring in its inside.

While holding down the lever, insert the wire into the (round) wiring hole until it reaches the deepest point. Once the lever is released, the wire is secured.

To check whether the wire is connected securely, pull the wire gently. (Do not pull the wire strongly.)

<Grounding>

Connect the detector to your grounding terminal with the external terminal .



WARNING

- Before turning on the detector, do not forget to connect it to a grounding terminal.
- For stable operation of the detector and safety, it must be connected to a grounding terminal. Do not connect the grounding wire to a gas pipe.
- The grounding must be made as D type grounding (below 100 Ω of grounding resistance).
- For the grounding wire, use cable lugs to safely connect it to a grounding terminal without looseness or twist.
- Use ring terminals to connect the grounding terminal with the ground and use the grounding wire with cross-sectional area of 4 mm² or more for the external grounding terminal.

<Wiring Example>

Connecting to the indicator

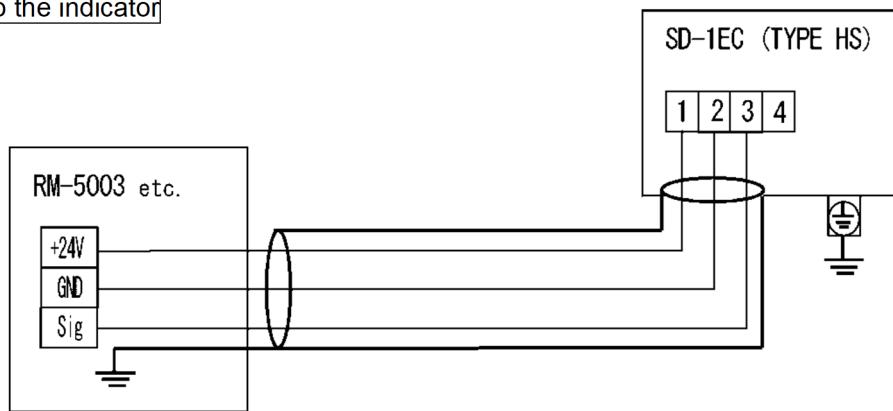

Connecting to the upper unit (DCS, PLC)

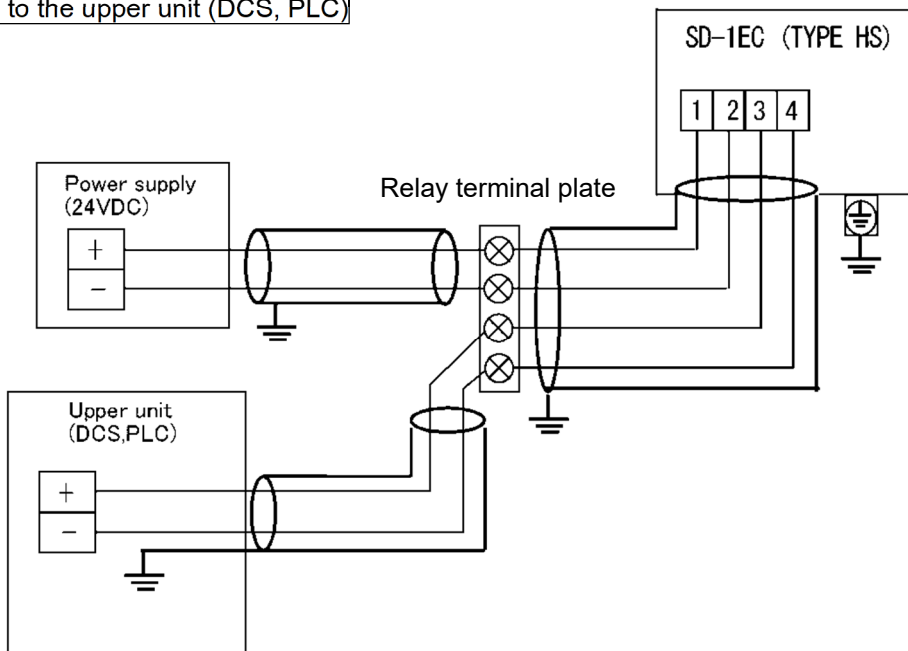

CAUTION

If HART communication is used, check so that wiring load resistance that constitute 4-20mA loops, amount to 250 Ω-300 Ω.

5

How to Operate

5-1. Preparation for start-up

Before connecting a power supply, read and understand the following precautions. Ignoring these precautions may cause an electric shock or damage the detector.

- Connect the detector to a grounding circuit.
- Check that the wiring is connected to external device properly.
- Check that the power supply voltage is compliant with the specifications.

5-2. Basic operating procedures

Normally, the detection mode is used for normal operations. (The detection mode is activated after the power is turned on.)

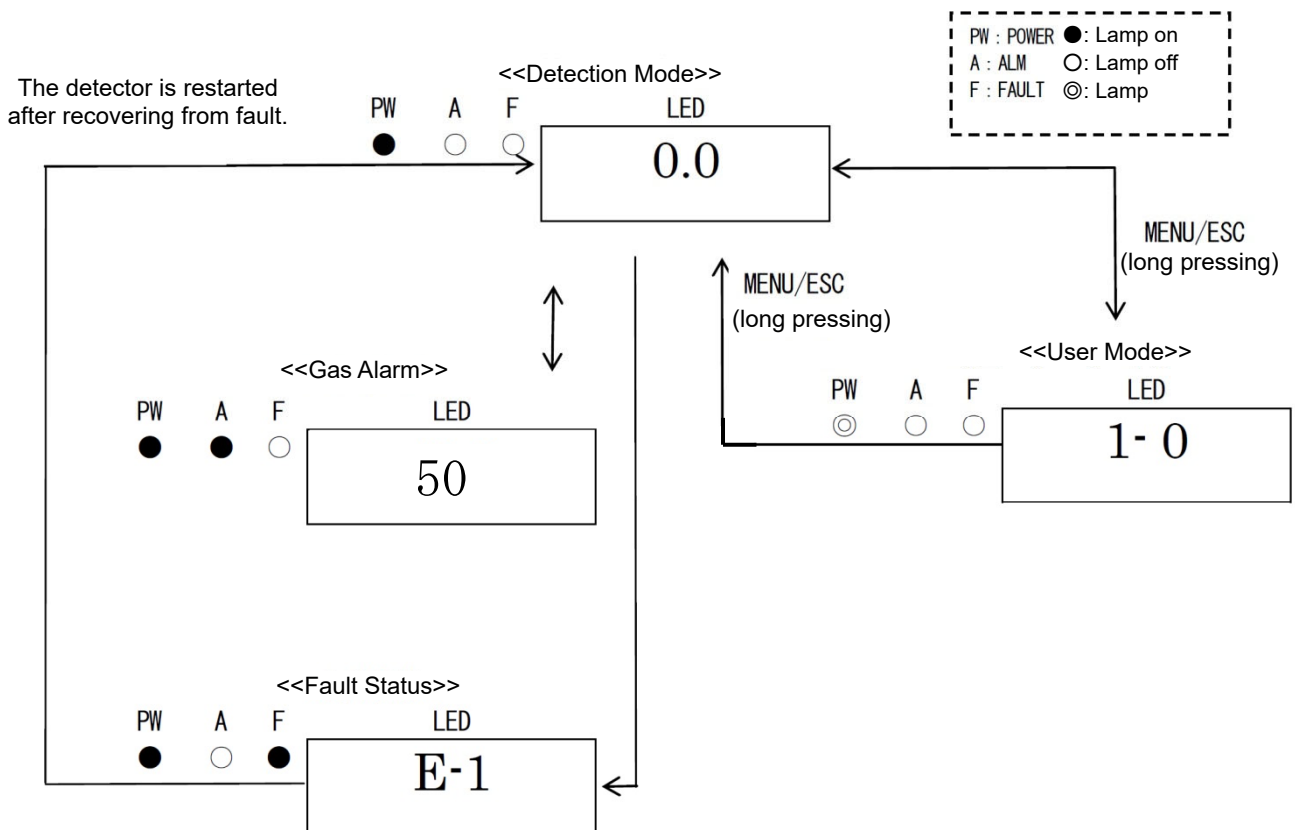

5-3. How to start the gas detector

- Before supplying power (24 VDC) to the detector, check that the detector is installed properly.
- Supply power (24 VDC) to the detector (turn on the detector).
- After the detector completes the start-up, it enters the detection mode swiftly.



CAUTION

- Do not turn off the detector during the initial clear. The detector is reading the internal memory during the initial clear.
- If the detector is installed newly or the new sensor is replaced, the sensor must be warmed up for a specified period which is determined depending on the type of the sensor after the detector is started.
- After the warm-up is completed, perform a calibration.

NOTE

<<Start-up Operation Procedures>> (approximately 25 seconds for system check of the detector and alarm deactivation)

Power on -> Initial clear (approximately 25 seconds) -> Detection mode

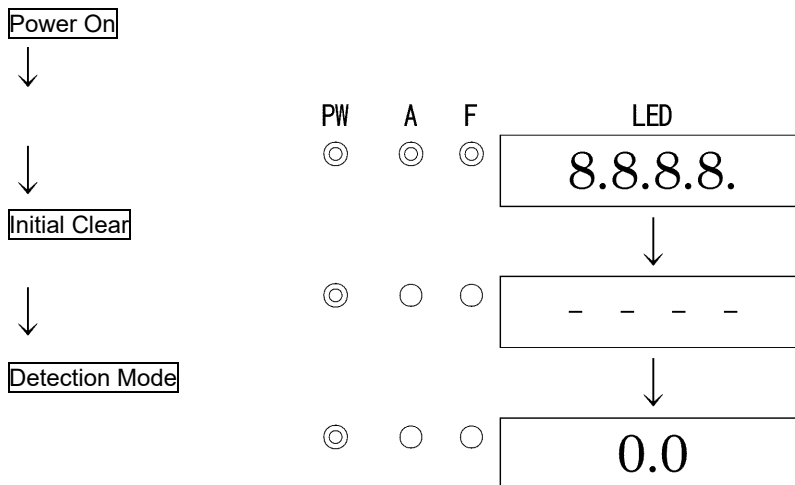

5-4. Modes

Details on each mode are provided as follows.



CAUTION

- An inside configuration changes of this detector is only for our service engineer. Setting change that user manipulated does not build up.

Mode	Item	LED display	Details
Detection Mode	-	Gas concentration	Normal state
User Mode	ROM/SUM Display	1-0	Display the program version and others.
	Zero Adjustment	1-1	Perform the zero adjustment.
	Setting Display	1-2	Display various setting values.
	Switch to Maintenance Mode	1-3	※

※Maintenance mode has setting item with important tool. As operation that mistook for this reason may be occurred, this detector to malfunction, our service engineer for maintenance manipulate. This is not typically used by the user.

5-5. User mode



WARNING

After the adjustment is completed, never fail to press MENU/ESC key to return to the detection mode.
 (If the detector remains in the user mode, it automatically returns to the detection mode in ten hours.)

Detection Mode

Press the MENU/ESC key for three seconds.

PW	A	F	LED
<input checked="" type="radio"/>	<input type="radio"/>	<input type="radio"/>	0.0



User Mode

1-0. ROM/SUM Display

Display the program version and others. This is not typically used by the user.

<input checked="" type="radio"/>	<input type="radio"/>	<input type="radio"/>	1- 0
----------------------------------	-----------------------	-----------------------	------



1-1. Zero Adjustment

Perform the zero adjustment.

<input checked="" type="radio"/>	<input type="radio"/>	<input type="radio"/>	1- 1
----------------------------------	-----------------------	-----------------------	------

→ Zero Adjustment => P26
 SET



1-2. Various Setting Display

Display various setting values.

<input checked="" type="radio"/>	<input type="radio"/>	<input type="radio"/>	1- 2
----------------------------------	-----------------------	-----------------------	------

→ Setting Display => P27
 SET



1-3. Mode Switching

Switch to the maintenance mode.

<input checked="" type="radio"/>	<input type="radio"/>	<input type="radio"/>	1- 3
----------------------------------	-----------------------	-----------------------	------

↓
 To 1-0

<Zero Adjustment "1-1">

Enter Zero Adjustment mode and prepare zero adjustment gas.

- Zero adjustment gas
- Gas sampling bag

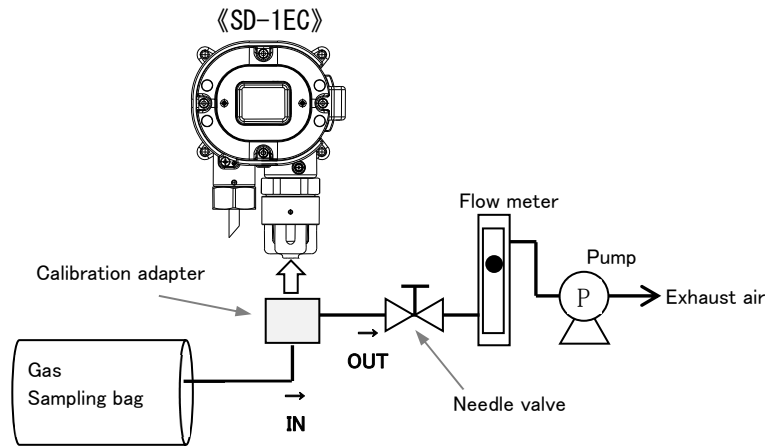

1-1

Press SET key.



Current Concentration Value Display

Press the SET key to perform the zero adjustment.



Under Zero Adjustment (CAL. is displayed)

Wait for a while until the adjustment is completed.



Zero Adjustment Completed

It automatically returns to 1-1 after PASS is displayed.

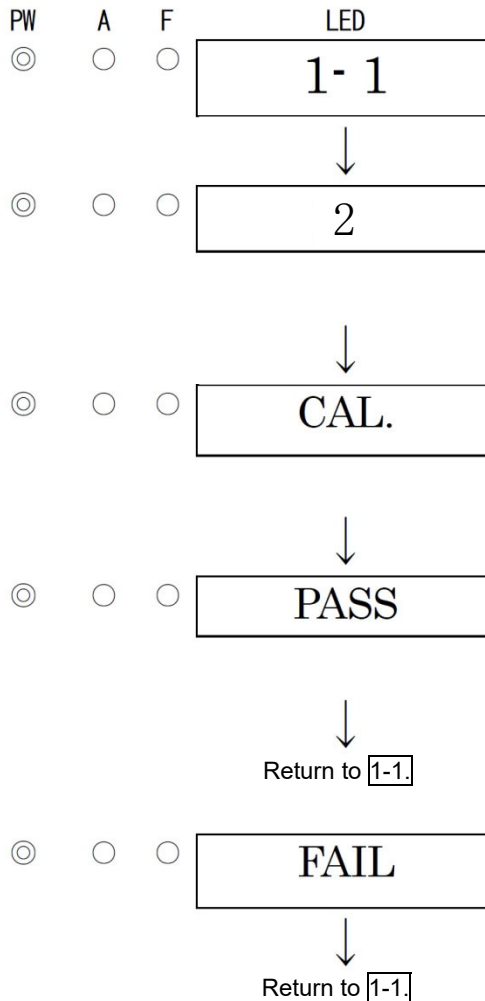

* If the zero adjustment failed, it automatically returns to 1-1 after FAIL is displayed.

NOTE

- If the zero calibration failed since the zero point was significantly fluctuated from around zero, it returns to 1-1 after FAIL rather than PASS is displayed. In this case, the zero adjustment has not been completed.
- Before starting the zero adjustment, provide the detector with the zero adjustment gas and wait until the indicator is stabilized.



WARNING

When the zero adjustment is performed in the atmosphere, check the atmosphere for freshness before beginning the adjustment. If other gases exist, the adjustment cannot be performed properly, thus leading to dangers when the gas leaks.

<Setting Display "1-2">

Display various setting values.

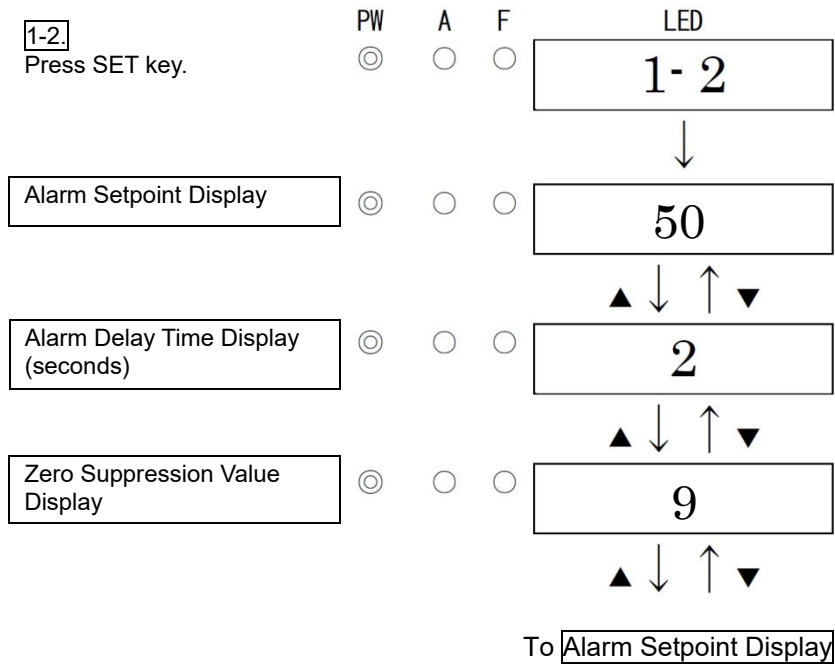

5-6. How to exit

To turn off the detector, turn off the power supply (24 VDC) to the detector.



WARNING

- When the detector is turned off, an alarm may be triggered on the upper (central) system.
- Before turning off the detector, INHIBIT (point skip) on the upper (central) system must be activated. Decide whether the power can be turned off by checking the operation of the devices connected to the external contact output terminal of the detector.

6

Operations and Functions

6-1. Gas alarm activation

Gas alarm: Activated when the concentration of detected gas reaches or exceeds the alarm setpoint value.
<<Auto-Reset Operation>>

NOTE

The alarm setpoint is factory-set. Although the alarm delay time (standard: 2 seconds) works in the detector to prevent a false activation, it can be cancelled if not needed.

<Display Operation>

Gas Concentration Display

In case of over the detection range (Over Scale), "∞ ∞ ∞ ∞" is displayed on the LED.

Power Indicator Lamp (POWER: Green)

During operation, this lights up continuously.

Alarm Indicator Lamp (ALM: Red)

This lights up when the alarm setpoint value is reached or exceeded.

<Alarm Activation>

It lights up when the gas concentration reaches or exceeds the alarm setpoint value. (only when the alarm is used)

The alarm activation is reset automatically when the gas concentration drops below the alarm setpoint value.

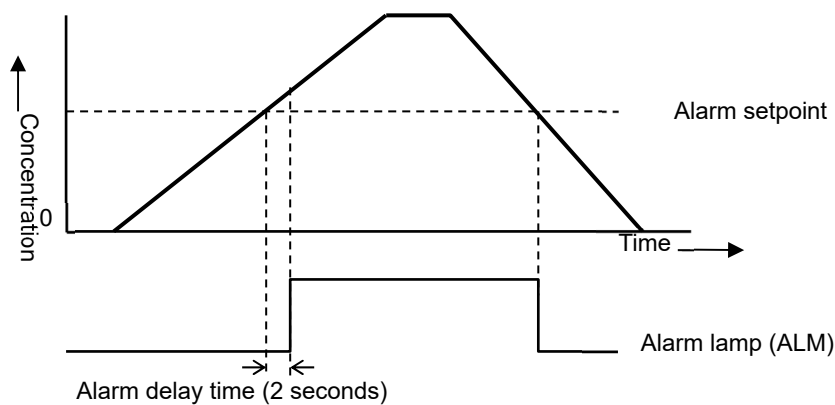

<Response to Gas Alarm>

A gas concentration value exceeds the alarm setpoint

When a gas alarm is triggered, take actions in accordance with your management rules of gas alarm. Normally, take the following actions.

- Check the reading of the detector.

NOTE

If a gas leak is momentary, the reading may already have dropped when checking it. In addition, when the alarm is triggered by noise or other incidental conditions other than a gas, the reading may have already dropped.

- Based on your management rules of gas alarm, no one can be allowed to access the monitored zone to ensure safety.
- If the gas concentration display continues to be displayed, close the main valve of the gas, and then check that the gas concentration reading dropped.
- Access the gas leak point, equipped with a protective gear to avoid dangers caused by possibly remaining gases, and check whether gases remain or not by using a portable gas detector.
- Check that the point is free from dangers, and take actions to fix the gas leak.

6-2. Fault alarm activation

A fault alarm is triggered when the detector detects abnormalities. After a fault alarm is triggered, the fault lamp (yellow) lights up and output below 3.6mA(about 0.5mA). As an Error message is displayed on the LED, determine the causes and take appropriate actions.

After the detector is successfully returned from the fault, it restarts with the process normally performed right after it is turned on (initial clear).

If the detector has problems and is repeatedly malfunctioning, contact RIKEN KEIKI immediately.

<Display Operation>

Fault Detail Display

Display a message indicating the fault detail.

Fault Lamp (FAULT: Yellow)

This lights up when a failure occurs.

NOTE

For information on malfunctions (error messages), see "9. Troubleshooting".

6-3. Warning activation

When the environmental temperature exceeds the operating temperature of the detector, gas concentration and warning number[E-27] are shown alternately. Since this case is not failure, still the detector works. It outputs 4-20mA depending on gas concentration and does not light up failure lamp.

Operating temperature : -10~+40°C(non-rapidly-vary)

6-4. External output operation

Signal Transmission System		Electric current transmission (non-isolated) 4 – 20 mA
Transmission Path		CVVS
Transmission Distance		CVVS 1.25 mm ² : Within 1.25km CVVS 2.0 mm ² : Within 2.0km
Connection Load Resistance		Below 300 Ω
	Mode	4 - 20 mA(output value)
1	Power Off	0 mA
2	Initial Clear	4 mA (Fixed)
3	Detection Mode(No alarm)	4 - 20 mA (concentration output)
4	Detection Mode(Gas alarm)	4 - 20 mA (concentration output)
5	Detection Mode (Full scale over)	20.5 mA (Fixed)
6	Out of operating temperature range	4 - 20 mA (concentration output)
7	Fault Alarm	0.5 mA (Fixed)
8	INHIBIT	4 mA (Fixed)
9	Alarm Test Mode	Output ON setting: 4 - 20 mA (concentration output) Output OFF setting: 4 mA
10	User Mode	4 - 20 mA (concentration output)
11	Maintenance Mode	4 mA (Fixed)

Example of Gas Concentration and External Output

4 - 20 mA specification

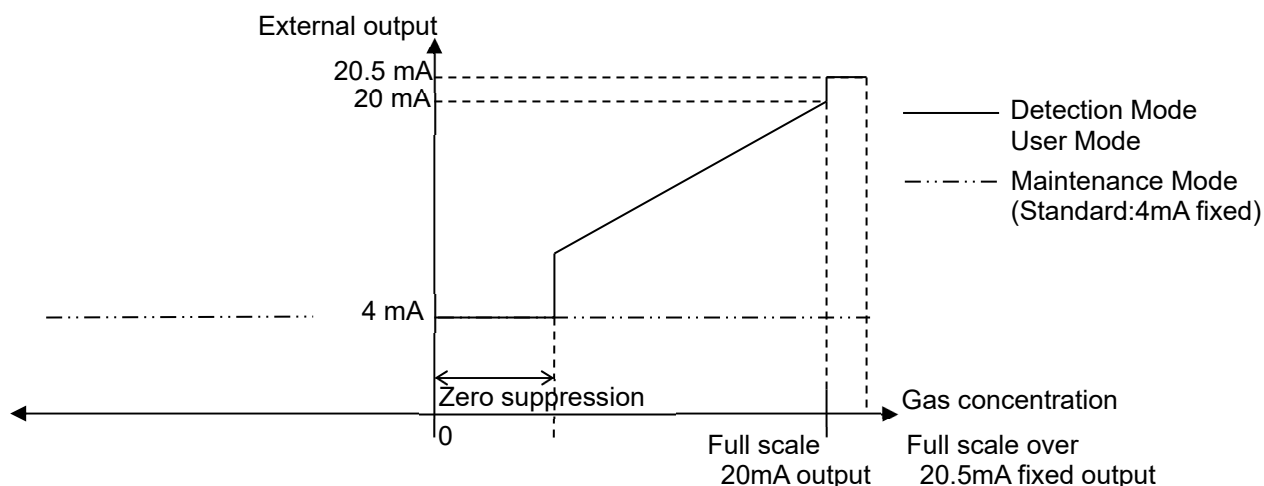

CAUTION

- The 4 - 20 mA output is already adjusted. In case of over scale, an output will not exceed 20.5 mA.
- Output during INHIBIT is based on 4 - 20 mA output setting in the maintenance mode. In particular, when the detector is started or the specification is changed, be careful about 4-20 mA output setting. Understand how the detector functions, and take actions, if necessary, so that

6-5. Other functions

<Suppression Function>

The sensors used with the detector are influenced by environmental changes (temperature, humidity and other characteristics) or interference gases (interference characteristics) in no small measure, which affects the reading. Therefore, the reading might be fluctuated around zero even in a normal environment. This function obscures influences by environmental changes and interference gases around zero that have no meaning for your management rules of gas alarm. This function is used to hide (suppress) the fluctuation of the reading under the setting value, indicating zero.

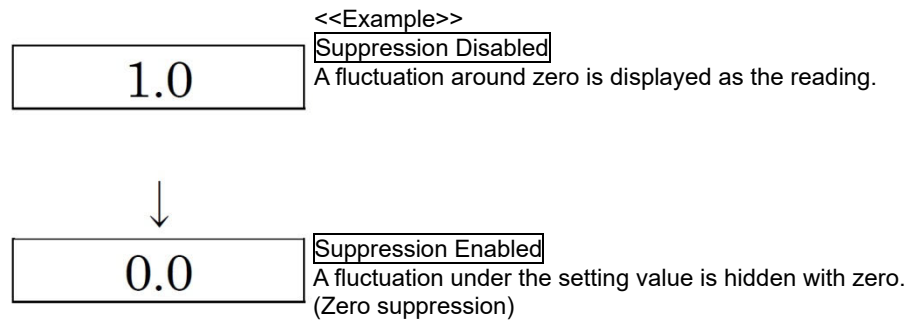

NOTE

- The suppression function is factory-set. The standard setting value is 6% F.S.
- In the maintenance mode, this function is disabled and the fluctuation of the reading under the setting value is displayed.



CAUTION

A reading under zero is suppressed with the 10% FS suppression.
A reading that gets 10% FS or more under zero is displayed as "-0.0", which prevents an accurate gas detection and needs the zero adjustment.

7

Maintenance

The gas detector is an important instrument for the purpose of safety. To maintain the performance of the gas detector and improve the reliability of safety, perform a regular maintenance.

7-1. Maintenance intervals and items

- Daily maintenance: Perform maintenance before beginning to work.
- Regular maintenance: Perform maintenance once or more for every six months to maintain the performance as a safety unit.

Maintenance item	Maintenance content	Daily maintenance	Regular maintenance
Power Supply Check	Check that the power lamp lights up.	○	○
Concentration Display Check	Check that the concentration display value is zero. When the reading is incorrect, perform the zero adjustment after ensuring that no interference gases exist around it.	○	○
Alarm Test	Inspect the alarm circuit by using the alarm test function.	—	○
Span Adjustment	Perform the span adjustment by using the calibration gas.	—	○
Gas Alarm Check	Check the gas alarm by using the calibration gas.	—	○

<About Maintenance Services>

- We provide services on regular maintenance including span adjustment, other adjustments and maintenance.
To make the calibration gas, dedicated tools, such as a gas cylinder of the specified concentration and gas sampling bag must be used.
Our qualified service engineers have expertise and knowledge on the dedicated tools used for services, along with other products. To maintain the safety operation of the detector, please use our maintenance service.
- The followings are typical maintenance services. For more information, please contact RIKEN KEIKI.

Main Services

Power Supply Check	: Checks the power supply voltage. Verifies that the power lamp lights up. (Verifies that relevant points can be identified on the system.) (When a UPS (uninterruptible power system) is used, checks the operation with the UPS.)
Concentration Display Check	: Verifies that the concentration display value is zero (or 20.9 vol% on the oxygen deficiency meter) by using the zero gas. Performs the zero adjustment (fresh air adjustment) if the reading is incorrect.
Flow Rate Check	: Checks the flow rate indicator to find abnormalities. Checks the flow rate by using an external flow meter to verify the correctness of the flow rate indicator on the gas detector. If the flow rate is incorrect, performs the flow rate adjustment.
Filter Check	: Checks the dust filter for dust or clogging. Replaces a dirty or clogged dust filter.
Alarm Test	: Inspects the alarm circuit by using the alarm test function. <ul style="list-style-type: none"> • Checks the alarm lamps. (Checks ALM1 activation.) • Checks the external alarm. (Checks the activation of the external alarm, such as a buzzer.)
Span Adjustment	: Performs the span adjustment by using the calibration gas.
Gas Alarm Check	: Checks the gas alarm by using the calibration gas. <ul style="list-style-type: none"> • Checks the alarm. (Checks triggering of alarm when the alarm setpoint is reached.) • Checks the delay time. (Checks time to delay until the alarm is triggered.) • Checks the alarm lamps. (Checks ALM1 activation.) • Checks the external alarm. (Checks the activation of external alarms, such as a buzzer and reset signal.)
Cleaning and Repair of Device (Visual Diagnosis)	: Checks dust or damage on surface, cover or internal parts of the detector, cleans and repairs such parts of the detector. Replaces parts which are cracked or damaged.
Device Operation Check	: Uses the keys to check the operation of functions and parameters.
Replacement of Consumable Parts	: Replaces consumable parts, such as a sensor, filter and pump.

7-2. Proof test

Proof Test is the test which confirms if a series of safety system function works properly. It should be performed at maintenance period (every 6 months) or whenever safety system is updated or changed. Refer to appendix, the safety manual.

If do not perform Proof Test, it will decrease SIL.

7-3. Parts replacement

List of recommended regular replacement parts

No.	Name	Maintenance intervals	Replacement intervals (year)	Quantity (pieces/unit)
1	Rubber seal	6 months	3 - 8 years	1
2	Slip ring	6 months	3 - 8 years	1
3	Charcoal filter CF-80(CO only)	6 months	1 year	1

- * The operation must be checked after replacement by a qualified service engineer. For the stable operation of the unit and safety, ask a qualified service engineer to take care of replacement of the parts that operation must be checked. Request RIKEN KEIKI for operation check.

NOTE

- The above replacement intervals are recommendation only. The intervals may change depending on the operating conditions. These intervals do not mean the warranty periods either. The result of the regular maintenance may determine when to replace the parts.

8

Storage, Relocation and Disposal

8-1. Procedures to store the gas detector or leave it for a long time

The gas detector must be stored under the following environmental conditions.

- In a dark place under the normal temperature and humidity away from direct sunlight
- In a place where gases, solvents or vapors are not present

8-2. Procedures to relocate the detector or use it again

When the detector is relocated, select a new place in accordance with "4-2. Precautions for installation sites" and "4-4. How to install".

For information on wiring, see "4-6. How to wire". The unpowered time must be minimized when the detector is relocated.



CAUTION

- When using a relocated or stopped/stored detector again, never fail to perform a calibration. For information on readjustment including a calibration, please contact RIKEN KEIKI.

8-3. Product disposal

Dispose of the product as industrial waste (incombustible) in accordance with local regulations.

<Disposal in EU member states>

- Waste Electrical and Electronic Equipment (WEEE) directive



The symbol on the product shown on the left indicates that the product and its individual parts must not be disposed of with general or household waste, and must be sorted and disposed of appropriately.

Proper disposal will help prevent potential negative effects on human health and the environment.

To ensure proper treatment, collection, and recycling of the product at the time of its disposal, please use the return and collection system available in your country. For more

information on collecting and recycling used products, please contact the dealer or supplier from whom you purchased the product.

9

Troubleshooting

The Troubleshooting does not explain the causes of all the malfunctions which occur on the detector. This simply helps to find the causes of malfunctions which frequently occur. If the detector shows a symptom which is not explained in this manual, or still has malfunctions even though remedial actions are taken, please contact our overseas sales department or local representatives.

<Abnormalities on Unit>

Symptom/Display	FAULT	Causes	Actions
<u>The power cannot be turned on.</u>	—	The wiring is not correct.	Connect the wiring properly.
		The terminal plate is removed.	Connect the terminal plate properly.
		Abnormalities/momentary blackout of power supply system	Provide the rated voltage. Take measures such as checking or adding the UPS, power supply line filter and insulation transformer.
		Cable abnormalities (open circuit/not connected/short circuit)	Check the wiring of detector and related devices around it.
<u>Abnormal operations</u>	—	Disturbances by sudden surge noise, etc.	Turn off and restart the indicator/alarm unit. If such a symptom is observed frequently, take appropriate measures to eliminate the noise.
<u>Sensor abnormalities</u> E-1	●	The sensor is not connected or improperly connected.	Check if the cable is securely fastened to the terminal plate.
		Zero drift caused by environmental changes or aging deterioration is out of the range of zero follower.	Perform zero adjustment. If the symptom persists after the zero adjustment, replace the sensor with a new one.
		Faults of the sensor	Replace the sensor with a new one.
<u>System abnormalities</u> E-9	●	The rated voltage is not supplied to the detector.	Check the power supply, and supply the rated voltage.
		Abnormalities of ROM, RAM or EEPROM inside of the detector	Please contact our overseas sales department or local representatives.
		Output signal (4-20mA) does not work correctly.	Make sure the output cable is connected properly. (Cable disconnection or connection to the host system.) If it is connected properly, the detector might be malfunction. Please contact RIKEN KEIKI.

<Abnormalities of Readings>

Symptoms	Causes	Actions
<u>The reading rises (drops) and it remains so.</u>	Drifting of sensor output	Perform zero adjustment.
	Presence of interference gas	Disturbances by interference gases, such as solvents, cannot be eliminated completely.
	Slow leak	A very small amount of the gas to be detected may be leaking (slow leak). Because ignoring it may cause dangers, take a remedial measure, i.e., taking actions the same as those for the gas alarm.
	Environmental changes	Perform the zero adjustment (AIR adjustment).
<u>A gas alarm is triggered despite of no gas leak and no other abnormalities at the detection point.</u>	Presence of interference gas	Disturbances by interference gases, such as solvents, cannot be eliminated completely.
	Disturbance by noise	Turn off and restart the detector. If such a symptom is observed frequently, take appropriate measures to eliminate the noise.
	Sudden change in the environment	When the environment (temperature etc.) changes suddenly, the detector cannot adjust to it and is affected by it. In some cases, the detector triggers an indication alarm. Because the detector cannot be used under sudden and frequent environmental changes, any preventive actions to eliminate them should be taken by the user.
<u>Slow response</u>	Deteriorated sensor sensitivity	Replace the sensor with a new one.
<u>Span adjustment impossible</u>	Improper calibration gas concentration	Use the proper calibration gas.
	Deteriorated sensor sensitivity	Replace the sensor with a new one.

<Abnormalities of installation environment>

Symptom/Display	FAULT	Causes	Actions
<u>Out of operating temperature range</u> E-27	—	The environmental temperature is out of operating temperature range	Operating temperature range is -10~+40°C. If environmental temperature is out of operating temperature range, countermeasure for adjusting environmental temperature is needed to be considered.

10

Product Specifications

10-1. List of specifications

<ATEX/IECEX Specification>

Model	SD-1EC
Type	TYPE HS
Detection principle	Electrochemical method
Detectable gas	H2S/CO
Gas concentration display	LED(4digits · 7segments)
Measuring range	H2S : 0 - 30ppm or 0 - 50ppm or 0 - 100ppm CO : 0 - 75ppm or 0 - 150ppm or 0 - 200ppm or 0 - 250ppm or 0 - 300ppm
Detection method	Diffusion method
Alarm preset point	Depend on Detectable gas
Power indication	POWER lamp lighting(green)
Output	Gas concentration signal
Alarm accuracy (under an identical condition)	Less than $\pm 30\%$ to the alarm setpoint value
Alarm-delay time (under an identical condition)	Less than 30sec (when introducing 1.6 times thicker gas than alarm setpoint value)
Gas alarm indication	ALM lamp lighting(red)
Gas alarm action	Auto-recover
Trouble alarm · Self diagnosis	System failure/Sensor failure
Trouble alarm indication	FAULT lamp lighting(yellow)/content display
Trouble alarm action	Auto-recover
Transmission scheme	Three-wire analog transmission(in common with power supply<power supply, signal, common>) or Two-wire analog transmission + digital transmission(HART communication)
Specification of transmission	4 - 20mA DC(linear · load resistance less than 300 Ω)
Communication scheme	HART 7
Transmission cable	CVVS worth of shield cable(1.25mm ²)·4-core or 3-core(3-core:HART communication unused) CVVS worth of shield cable(2.0mm ²)·4-core or 3-core(3-core:HART communication unused)
Transmission distance	Less than 1.25km in case of CVVS 1.25mm ² Less than 2.0km in case of CVVS 2.0mm ²
Various functions	Alarm delay/Suppress/HART communication
Power supply	24VDC $\pm 10\%$
Power consumption	MAX.1.1W
Cabling port	Adapter A<NPT1/2> or Adapter B<NPT3/4> or Adapter<M20 × 1.5> or Flame proof packing method<G3/4>(Compatible cables $\phi 9.6 - 13.0$ mm in outer diameter)
Initial clear	Approx.25sec
Operating temperature	-10 - +40°C(non-rapidly-vary)
Operating humidity	30 - 80%RH(non-condensing)
Structure	Wall mounting type

Explosion-proof structure	Flame proof structure
Explosion-proof grade	II 2 G Ex db II C T6 Gb(ATEX) / Ex db II C T6 Gb(IECEX)
SIL certified	Implemented in relation to IEC 61508:2010 Part 2 and Part 3 Conformity to SIL 2 Conformity to SIL 3 by duplicate
Outer dimension	Approx.148(W)×203(H)×88(D)mm(projection excluding)
Weight	Approx.2.2kg
Color	Munsell 7.5BG5/2

Outline Drawings

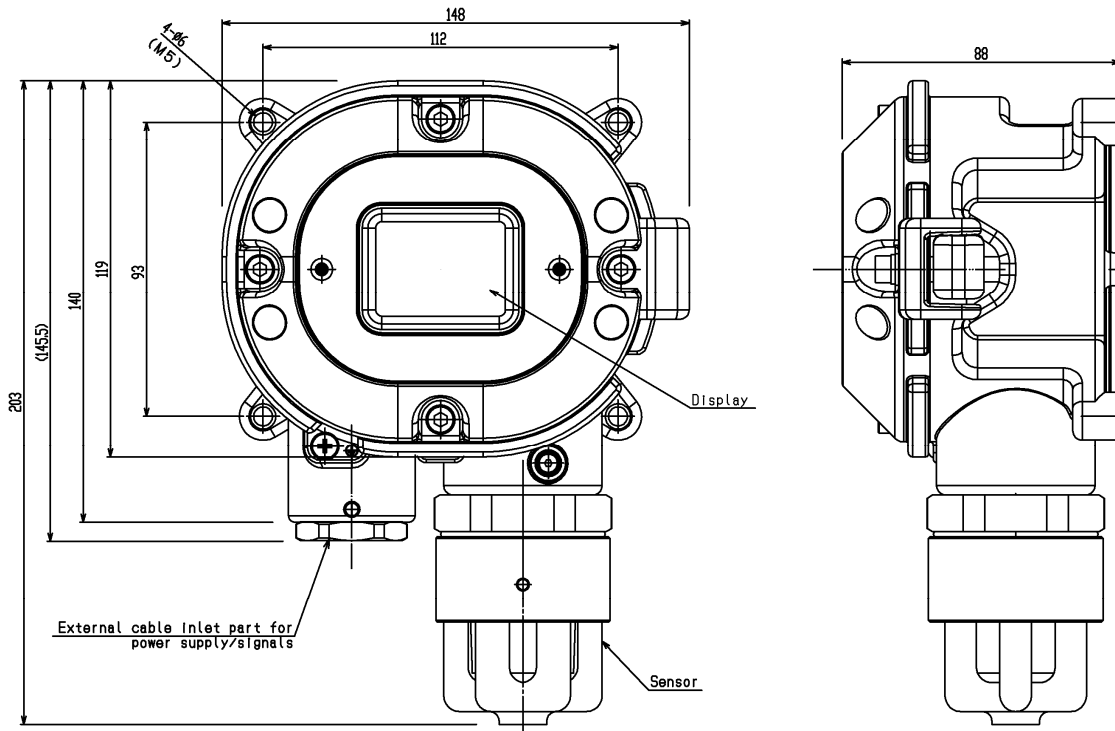

<Japan Ex Specification>

Model	SD-1EC
Type	TYPE HS
Detection principle	Electrochemical method
Detectable gas	H ₂ S/CO
Gas concentration display	LED(4digits・7segments)
Measuring range	H ₂ S : 0 - 30ppm or 0 - 50ppm or 0 - 100ppm CO : 0 - 75ppm or 0 - 150ppm or 0 - 200ppm or 0 - 250ppm or 0 - 300ppm
Detection method	Diffusion method
Alarm preset point	Depend on Detectable gas
Power indication	POWER lamp lighting(green)
Output	Gas concentration signal
Alarm accuracy (under an identical condition)	Less than ±30% to the alarm setpoint value
Alarm-delay time (under an identical condition)	Less than 30sec (when introducing 1.6 times thicker gas than alarm setpoint value)
Gas alarm indication	ALM lamp lighting(red)
Gas alarm action	Auto-recover
Trouble alarm・Self diagnosis	System failure/Sensor failure
Trouble alarm indication	FAULT lam lighting(yellow)/content display
Trouble alarm action	Auto-recover
Transmission scheme	Three-wire analog transmission(in common with power supply<power supply, signal, common>) or Two-wire analog transmission + digital transmission(HART communication)
Specification of transmission	4 - 20mA DC(linear・load resistance less than 300Ω)
Communication scheme	HART 7
Transmission cable	CVVS worth of shield cable(1.25mm ²)・4-core or 3-core(3-core:HART communication unused) CVVS worth of shield cable(2.0mm ²)・4-core or 3-core(3-core:HART communication unused)
Transmission distance	Less than 1.25km in case of CVVS 1.25mm ² Less than 2.0km in case of CVVS 2.0mm ²
Various functions	Alarm delay/Suppress/HART communication
Power supply	24VDC±10%
Power consumption	MAX.1.1W
Cabling port	Flame proof packing method<G3/4>(Compatible cables φ9.6~13.0mm in outer diameter)
Initial clear	Approx.25sec
Operating temperature	-10 - +40°C(non-rapidly-vary)
Operating humidity	30 - 80%RH(non-condensing)
Structure	Wall mounting type
Explosion-proof structure	Flame proof structure
Explosion-proof grade	Ex d II C T6 X
SIL certified	Implemented in relation to IEC 61508:2010 Part 2 and Part 3 Conformity to SIL 2 Conformity to SIL 3 by duplicate
Outer dimension	Approx.148(W)×203(H)×88(D)mm(projection excluding)
Weight	Approx.2.2kg
Color	Munsell 7.5BG5/2

Outline Drawings

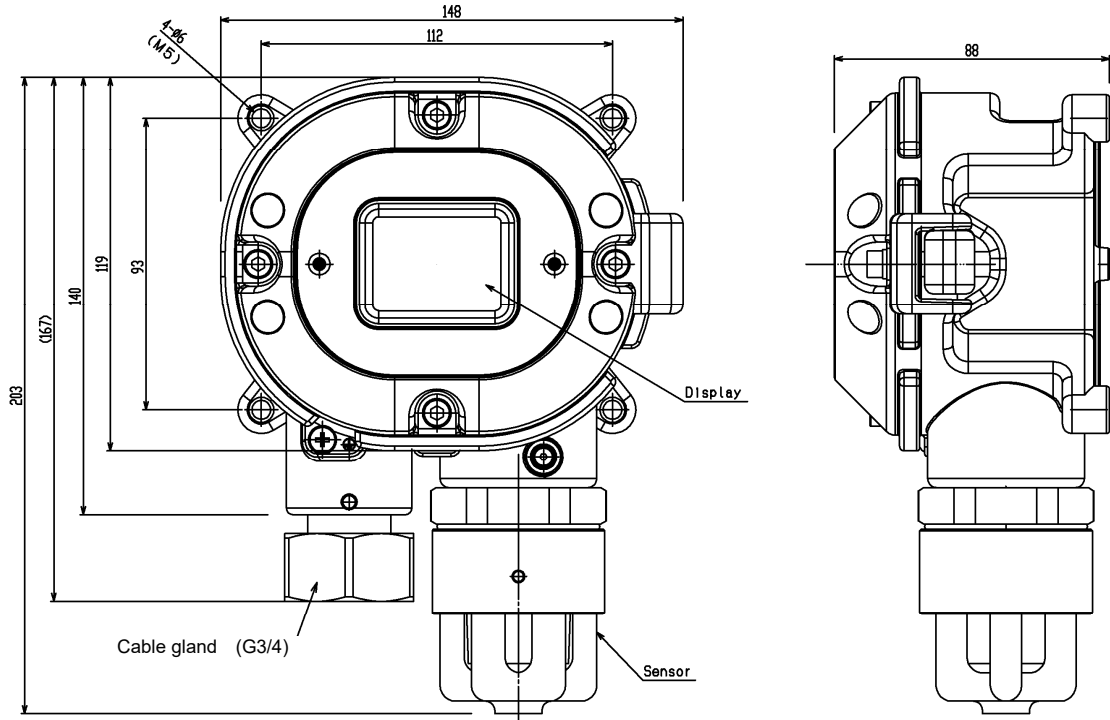

10-2. Detection principle

[Detection principle]

An electrochemical type sensor electrolyzes a gas directly while maintaining the interface between electrode and electrolyte at a constant potential (bias voltage). A gas is electrolyzed by an electrolysis cell to which a certain potential (bias voltage) is applied, and the gas is detected from the electrolytic current generated at that time.

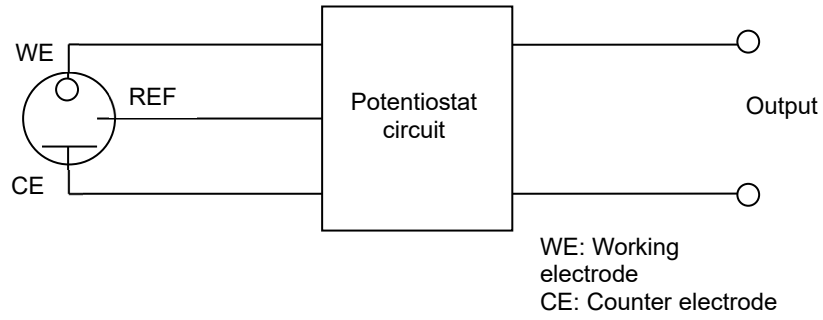

11

Definition of Terms

Electrochemical type	This is a principle of the sensor installed in the detector head. See "10-2. Detection principle" for details.
Initial clear	Output from the detector head fluctuates for a while after turning on the power. This is a function to prevent triggering alarm during that time.
Full scale	Maximum value of the detection range.
ppm	A concentration unit that means part per million of the combustible gas to be detected.
Calibration	Adjusts the readings to the calibration gas concentration value by using the calibration gas.
Zero suppression	A function to cut off the specific drifting that the sensor has.
Alarm delay time	A function which temporarily suspends activation to prevent a false alarm caused by noise from its outside.
INHIBIT	The gas detection function is temporarily suspended during maintenance etc. of the detector. This is also called "point skip", which has the same function.
HART communication	DC4-20mA signal digitals signalling is superimposed, and is methods that transmit multiple signals.
IEC 61508	International standard on functioning safety of electrical, electronics and programmable electronic in process industry established by IEC (International Electrotechnical Commission)
Functional safety	Ensuring levels of safety that it acceptable that implements functional device(functions that safety are secured) to the final products.
SIL	Measure that safe performance of indicator and systems in IEC 61508.