



PT2E-2277

# **Smart Transmitter/Gas Detector Head**

## **SD-1GH**

**(TYPE H)**

**Operating Manual**

**(PT2E-169)**

**(PT2-169)**

**RIKEN KEIKI Co., Ltd.**

2-7-6 Azusawa, Itabashi-ku, Tokyo, 174-8744, Japan

Phone : +81-3-3966-1113

Fax : +81-3-3558-9110

E-mail : [intdept@rikenkeiki.co.jp](mailto:intdept@rikenkeiki.co.jp)

Web site : <https://www.rikenkeiki.co.jp/>

## Operating Precautions

This detector is a gas detector that detects combustible gases in the air and triggers a gas alarm. The gas detector is a safety unit, not an analyzer or densitometer which performs quantitative/qualitative analysis/measurement for gases.

Please fully understand the following points before using it, so that it can be used properly.

1. This detector may be interfered by gases and vapors other than the gas to be detected. Please note that the alarm may be triggered by interference. In addition, it may be fluctuated by environmental (temperature, humidity, etc.) changes in the installation site.
2. The alarm must be set within a range where the performance of the detector can be ensured. In facilities compliant with the High Pressure Gas Safety Act, an alarm setting below our standard alarm setpoint may trigger a false alarm.
3. If use in safety unit, the analog signal output of the detector must be used for an indicator or external recorder. If these outputs are used to control other units, we shall not be responsible for any malfunctions.
4. The gas sensing part of the gas detection sensor installed in this detector is made of metal porous sintered alloy permeated with an oxidation catalyst. If silicon or sulfide compounds are accumulated on the surface of porous sintered alloy, the area of the gas sensing part becomes smaller, which may results in serious deterioration of its sensitivity. For safety reasons, do not use the detector under the presence of silicon or sulfide compounds even though their amount is very small.
5. For maintenance of the detector, it must go through a regular maintenance, including replacement and adjustment of the regular replacement parts as specified in the operating manual. In addition, because this is a safety unit, it is recommended that a regular maintenance and a gas calibration are performed every six months in accordance with the regulations.

---

## <Contents>

1. Outline of the Product.....	2
1-1. Preface.....	2
1-2. Purpose of use.....	2
1-3. Definition of DANGER, WARNING, CAUTION, and NOTE.....	3
1-4. Method of confirmation for Standards and Explosion proof specification.....	3
2. Important Notices on Safety.....	4
2-1. Danger cases.....	4
2-2. Warning cases.....	5
2-3. Precautions.....	6
2-4. Safety information.....	7
3. Product Components.....	9
3-1. Main unit and standard accessories.....	9
3-2. Names and functions for each part.....	10
3-3. Block diagram.....	11
4. How to Use.....	12
4-1. Before using the detector.....	12
4-2. Precautions for installation points.....	12
4-3. Precautions for system designing.....	13
4-4. How to install.....	15
4-5. Installation procedure.....	16
4-6. How to wire.....	18
5. How to Operate.....	22
5-1. Preparation for start-up.....	22
5-2. Basic operating procedures.....	22
5-3. How to start the detector.....	23
5-4. Modes.....	25
5-5. User mode.....	26
5-6. How to exit.....	28
6. Operations and Functions.....	29
6-1. Gas alarm activation.....	29
6-2. Fault alarm activation.....	30
6-3. External output operation.....	31
6-4. Other functions.....	32
7. Maintenance.....	33
7-1. Maintenance intervals and items.....	33
7-2. Regular maintenance mode.....	35
7-3. Gas calibration method.....	43
7-4. Parts replacement.....	46
8. Storage, Relocation and Disposal.....	48
8-1. Procedures to store the detector or leave it for a long time.....	48
8-2. Procedures to relocate the detector or use it again.....	48
8-3. Disposal of products.....	48
9. Troubleshooting.....	49
10. Product Specifications.....	51
10-1. List of specifications.....	51
10-2. List of accessories.....	54
10-3. Detection principle.....	55
11. Definition of Terms.....	56

---

# 1

---

# Outline of the Product

## 1-1. Preface

Thank you for choosing our smart transmitter/gas detector head SD-1GH(TYPE H). Please check that the model number of the product you purchased is included in the specifications on this manual.

This manual explains how to use the detector and its specifications. It contains information required for using the detector properly. Not only the first-time users but also the users who have already used the product must read and understand the operating manual to enhance the knowledge and experience before using the detector.

Although the number of digits to display varies depending on the detection range, this manual provides explanation using a detection range from 0 to 100.0 as examples (such as examples of LED display).

Product specifications may be abbreviated in this document as follows.



Japan Ex specification : Japan specification

ATEX / IECEx specification : Export specification

## 1-2. Purpose of use

- This detector is a fixed type gas detector head that detects leak of combustible/toxic gases and performs the alarm activation when the gas concentration is over the setting value.
- The detector is a safety unit, not an analyzer or densitometer which performs quantitative/qualitative analysis/measurement for gases. Please fully understand the features of the detector before using it, so that it can be used properly.
- The detector detects abnormalities in the air caused by presence of gases or other reasons (leak) with the built-in gas sensor. The concentrations of detected gases are displayed on the seven-segment LED.
- The detector outputs gas concentration in 4 – 20 mA.
- The detector has HART communication function, and for specification with blow-by-blow HART communication refer to the separate volumes [HART communication function manual].

# 1-3. Definition of DANGER, WARNING, CAUTION, and NOTE

 <b>DANGER</b>	This message indicates that improper handling may cause serious damage on life, health or assets.
 <b>WARNING</b>	This message indicates that improper handling may cause serious damage on health or assets.
 <b>CAUTION</b>	This message indicates that improper handling may cause minor damage on health or assets.
<b>NOTE</b>	This message indicates advice on handling.

# 1-4. Method of confirmation for Standards and Explosion proof specification

This instrument has some specification depends on standard and explosion proof certificate. Please confirm the detector specification before using. Please refer Declaration of Conformity that is at the end of this manual if you have CE marking type. You can confirm instrument specification to see name plate as follows.

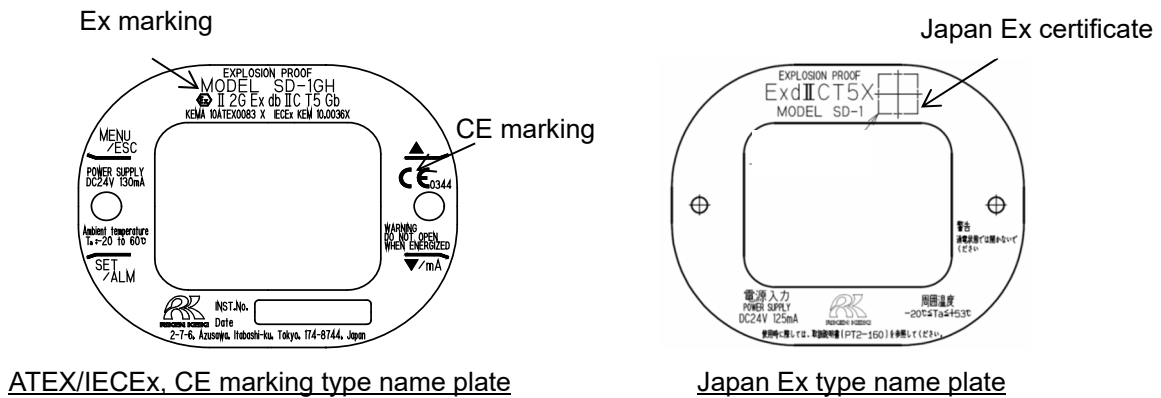

---

**2**

---

# Important Notices on Safety

## 2-1. Danger cases



### **DANGER**

#### About explosion-proof

- The window plate material is a polycarbonate resin. Do not use organic solvents and alkali types (liquid or vapor). It may cause the color and shape of the window plate to be changed.
- Do not open the lid when applying current.
- Do not attempt to repair the detector.
- For the lid, use hexagon socket head bolts specified by RIKEN KEIKI.
- Do not apply a strong force or shock to the window plate. The explosion-proof performances may be deteriorated due to damages. The explosion protection conditions for the detector is "low (2J)" possibility of mechanical damage.
- Do not replace parts at your sole discretion but contact RIKEN KEIKI if the transparent window has a crack or the explosion-proof joint surface is abnormal, or the clamping screw or bolt is changed, lost etc.
- Do not repair the explosion-proof joint surface.
- Be careful not to hit sharp tools against the window plate.

## 2-2. Warning cases



### WARNING

#### Power supply

Before turning on the detector, always check that the voltage is properly applied. Do not use an unstable power supply because it may cause malfunctions.

#### Need of grounding circuit

Do not cut the grounding circuit or disconnect the wire from the grounding terminal.

#### Defects in protective functions

Before starting the detector, check the protective functions for defects. When seeming defects are found in the protective functions, such as protective grounding, do not start the detector.

#### External connection

Before connecting the detector to the external control circuit, securely connect it to a protective grounding circuit.

#### Zero adjustment in the atmosphere

When the zero adjustment is performed in the atmosphere, check the atmosphere for freshness before beginning the adjustment. If other gases exist, the adjustment cannot be performed properly, thus leading to dangers when the gas leaks.

#### Response to gas alarm

Issuance of a gas alarm indicates that there are extreme dangers. Take proper actions based on your judgment.

## 2-3. Precautions



### CAUTION

Do not use a transceiver near the detector.

Radio wave from a transceiver near the detector or its cables may disturb indication reading. If a transceiver is used, it must be used in a place where it disturbs nothing.

To restart the detector, wait for five seconds or more before doing it.

Restarting the detector within five seconds may cause errors.

Do not use the external output of the detector to control other units.

This is not a control unit. It is not allowed to use the external output of the detector to control other units.

Do not disassemble/modify the detector, or change the settings if not necessary.

Disassembling/Modifying the detector will invalidate the warranty of the performance. Changing the settings without understanding the specifications may cause alarm malfunctions. Please use the detector properly in accordance with the operating manual.

Avoid applying organic solvents and others to the window plate for a long time.

The window plate material is a polycarbonate resin. When organic solvents (liquid or highly-concentrated vapor) and others are applied to the plate for a long time, its color and shape may be changed.

Do not forget to perform a regular maintenance.

Since this is a safety unit, a regular maintenance must be performed to ensure safety. Continuing to use the detector without performing a maintenance will deteriorate the sensitivity of the sensor, thus resulting in inaccurate gas detection.



## 2-4. Safety information

### Necessary information for explosion proof construction of Model SD-1GH (TYPE H).

The Model SD-1GH (TYPE H) is a fixed mount, continuous-monitoring detector head and provides a 4-20mA signal which indicates the target gas reading for use by a gas monitoring controller, recording device, or programmable controller.

<ATEX/IECEX Specification>

#### Technical Data

(Protection Method)	Flameproof enclosure “d”
(Certificate numbers)	IECEX KEM 10.0036X KEMA 10ATEX0083 X
(Group)	II
(Category)	2G
(Type of Protection and Marking code)	Ex db IIC T5
(Equipment Protection Level)	Gb
(Ambient Temperature)	-20°C to +60°C
(Electrical Data)	Supply voltage: 24 V dc (Typ.) Output signal: 4 to 20 mA
(Applicable Standard)	IEC 60079-0: 2017, IEC 60079-1: 2014-06 EN IEC 60079-0: 2018, EN 60079-1: 2014
(Manual number)	PT2E-169

#### Installation

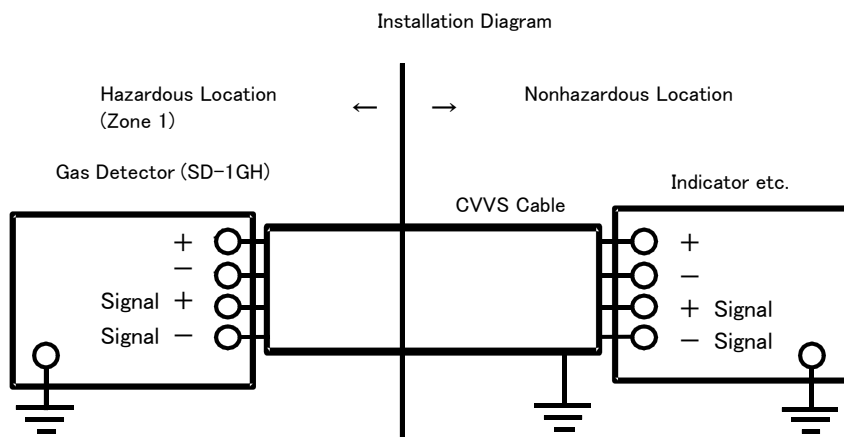

<Japan Ex Specification>

### Technical Data

(Protection Method)	Flameproof enclosure
(Explosion-proof class)	Ex d IIC T5 X
(Ambient Temperature)	-20°C to +53°C
(Electrical Data)	Supply voltage: DC24V 130mA Analog signal output: DC24V 25mA
(Applicable Standard)	JNIOSH-TR-NO. 43(2008)

### Installation

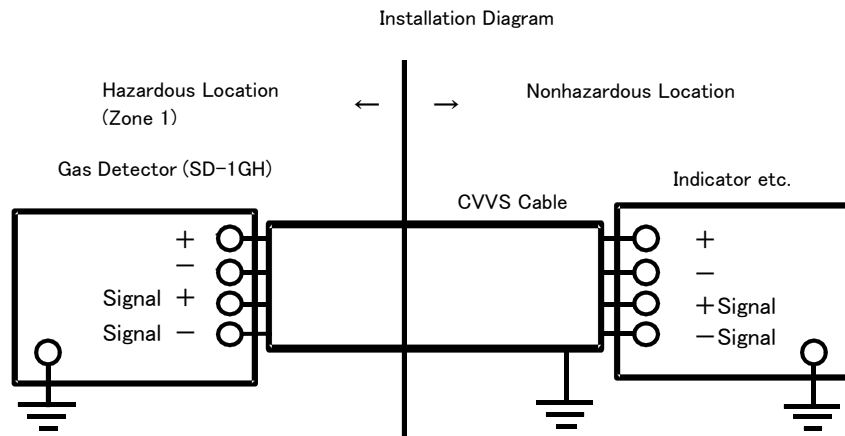

3

# Product Components

## 3-1. Main unit and standard accessories

<Main Unit> (including a cable gland)  
 【Export Specification】

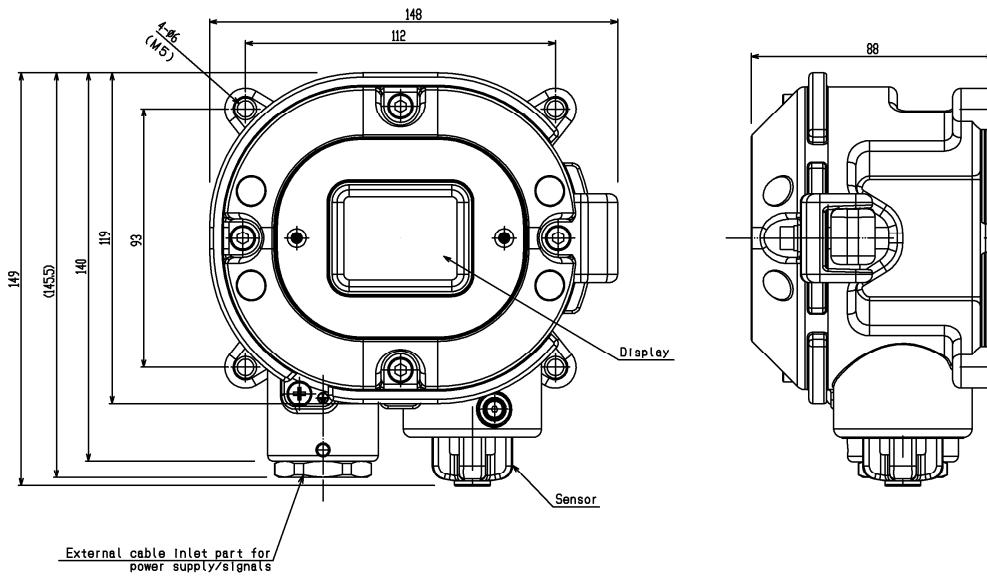

【Japan Specification】

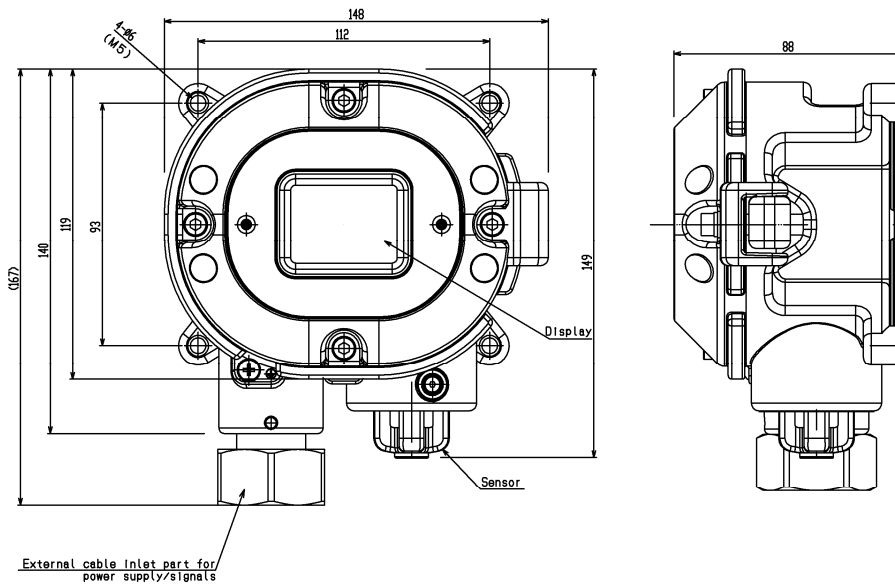

**<Standard Accessories>**

- Operating manual
- Dedicated handling lever (used for the wiring)
- Dedicated control key

## 3-2. Names and functions for each part

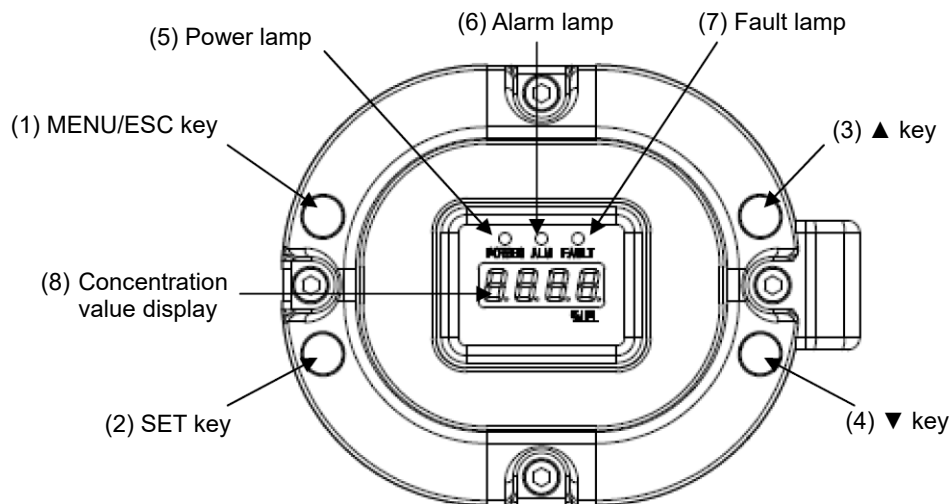

(1)	MENU/ESC key	Used to enter the maintenance mode. It is also used to cancel in a specific mode.
(2)	SET key	It is used for value confirmation and so on in a specific mode.
(3)	▲ key	Used to switch menus or change a value (UP).
(4)	▼ key	Used to switch menus or change a value (DOWN).
(5)	Power lamp	Power lamp: Detection mode: It lights up in green. Maintenance mode: It blinks in green.
(6)	Alarm lamp	Alarm lamp. It lights up in red when the alarm setpoint value is reached.
(7)	Fault lamp	Fault lamp. It lights up in yellow when an abnormality is detected in the detector.
(8)	Concentration value display	Displays the gas concentration and so on.



### CAUTION

Use the supplied dedicated control key to operate the detector. If products other than these accessories are used, key operations cannot be accepted properly.  
Note that the control key is made of extremely strong magnet. Putting it close to a magnetic product, such as a credit card and ID card, may damage the stored data.

### 3-3. Block diagram

<Electric Diagram>

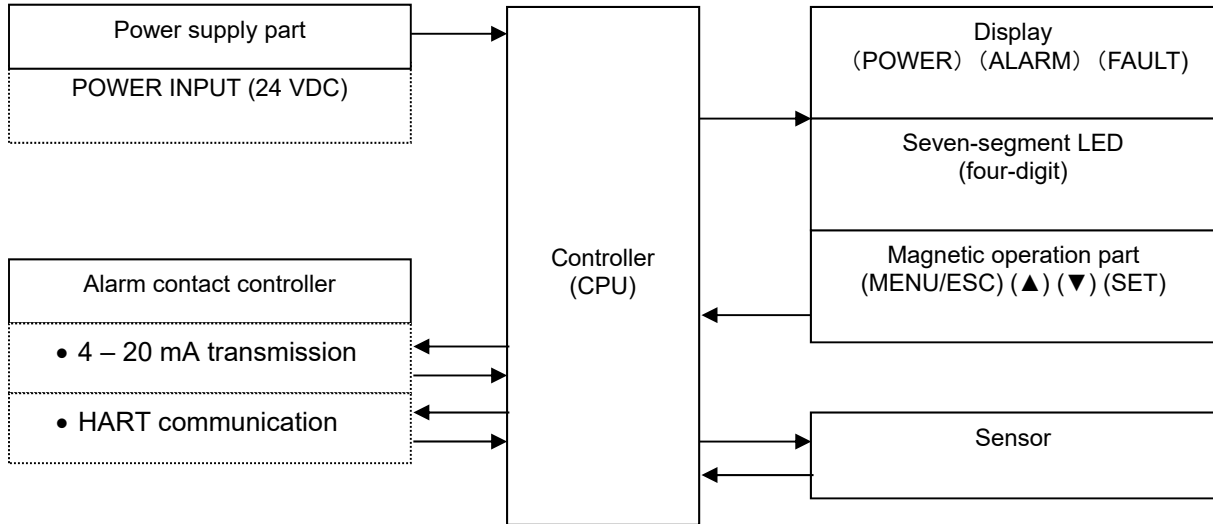

---

## 4

---

# How to Use

### 4-1. Before using the detector

Not only the first-time users but also the users who have already used the product must follow the operating precautions.

Ignoring the precautions may damage the detector, resulting in inaccurate gas detection.

### 4-2. Precautions for installation points



#### CAUTION

This is a precision device. Because the detector may not provide the specified performance in some places (environments), check the environment in the installation point, and then take appropriate actions if necessary.

Because the detector plays an important role for safety and disaster prevention, as many units of the detector as needed must be installed in appropriate points.

Because points where gases leak and remain easily are different depending on the types of gases and the working areas, please decide carefully on installation points and the number of units to be installed.

Do not install the detector in a place with vibrations or shocks.

The detector consists of sensitive electronic parts. The detector must be installed in a stable place without vibrations or shocks and it cannot drop.

Do not install the detector in a place exposed to water, oil or chemicals.

When selecting installation points, avoid a place where the detector is exposed to water, oil or chemicals.

Do not install the detector in a place where the range of operating temperatures is exceeded.

The detector must be installed in a stable place where the operating temperature is maintained and do not change suddenly.

<Export Specification> -20 to +60°C

<Japan Specification> -20 to +53°C

Do not install the detector in a place exposed to direct sunlight or sudden changes in the temperature.

When selecting installation points, avoid a place where it is exposed to direct sunlight or radiant heat (infrared rays emitted from a high-temperature object), and where the temperature changes suddenly. Condensation may be formed inside the detector, or the detector cannot adjust to sudden changes in the temperature.

Keep the detector (and its cables) away from noise source devices.

When selecting installation points, avoid a place where high-frequency/high-voltage devices exist.

Do not install the detector in a place where maintenance of the detector cannot be performed or where handling the detector involves dangers.

Regular maintenance of the detector must be performed.

Do not install the detector in a place where the machinery must be stopped when maintenance is performed in its inside, where parts of the machinery must be removed to perform maintenance, or where the detector cannot be removed because tubes or racks prevent access to it. Do not install the detector in a place where maintenance involves dangers, for example, near a high-voltage cable.

Do not install the detector in machinery which is not properly grounded.

Before installing the detector in machinery, the machinery must be grounded properly.

Do not install the detector in a place where other gases exist around it.

The detector must not be installed in a place where other gases exist around it.

## 4-3. Precautions for system designing



### CAUTION

An unstable power supply and noise may cause malfunctions or false alarms.

The descriptions in this section must be reflected on the designing of a system using the detector.

Using a stable power supply

The external output of the detector may be activated when the power is turned on, when momentary blackout occurs, or while the system is being stabilized. In such cases, use a UPS, or take appropriate actions on the receiving side of output signals.

The detector must be provided with the following power supply.

Power supply voltage	24 VDC (17 – 26.4 VDC): Terminal voltage of the detector	
Allowed time of momentary blackout	Up to 10 milliseconds (To recover from the momentary blackout for 10 milliseconds or more, restart the detector.)	<u>Example of actions</u> To ensure continuous operation and activation, install a UPS outside the detector.
Others	Do not use it with a power supply of large power load or high-frequency noise.	<u>Example of actions</u> Use a line filter to avoid the noise source if necessary.

Introducing protective measures against lightning

If cables are installed outside the factory/plant, or if internal cables are installed in the same duct as the cables coming from outside the factory/plant, "lightning" will cause problems. Because lightning acts as a large emission source while cables act as a receiving antenna, devices connected to the cables may be damaged.

Lightning cannot be prevented. Cables installed in a metal conduit or under the ground cannot be completely protected from inductive lightning surge caused by lightning. Although complete elimination of disasters caused by lightning is impossible, the following protective measures can be taken.

---

Protection against lightning	<u>Take appropriate measures in accordance with the importance of the facilities and the environment.</u> <ul style="list-style-type: none"><li>• Provide protection by a lightning arrester (cable arrester). (Although inductive lightning surge can be transmitted through the cable, it is prevented by installing a lightning arrester before the field devices and central processing equipment. For information on how to use a lightning arrester, please contact the manufacturer.)</li></ul>
Grounding	In addition to lightning, there are more sources of surge noise. To protect units from these noise sources, the units must be grounded.

\* The lightning arrester has a circuit to remove a surge voltage which damages field devices, so that signals may be attenuated. Before installing a lightning arrester, verify that it works properly.



## 4-4. How to install

### <Installation Dimensions and Maintenance Space>

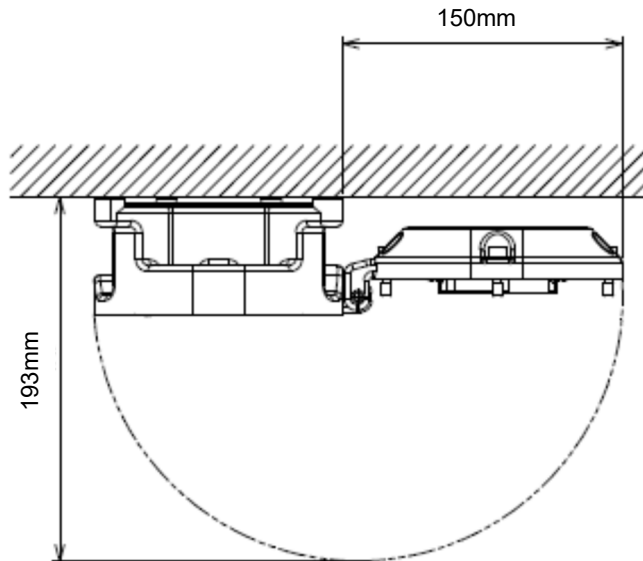

The following installation requirements must be met to install the detector.

- Attach the detector on the wall and others using four M5 screws.
- Tighten the hexagon socket head cap bolt fixing the lid and the main body with a tightening torque of  $215.6 \pm 24.5 \text{ N} \cdot \text{cm}$ .
- When closing the lid of the detector, make sure that there is no dust on screw, surfaces of the main body and lid. Then apply grease as specified by RIKEN KEIKI.



### CAUTION

Do not install the detector in a place where maintenance of the detector cannot be performed or where handling the detector involves dangers.

Regular maintenance of the detector must be performed.

Do not install the detector in a place where the machinery must be stopped when maintenance is performed in its inside, where parts of the machinery must be removed to perform maintenance, or where the detector cannot be removed because tubes or racks prevent access to it. Do not install the detector in a place where maintenance involves dangers, for example, near a high-voltage cable.

### NOTE

- Hexagon socket head cap bolt with strength class "A2-70" are used.  
When you lost or replace it, we recommend that you ask our local sales office nearest you.
- Grease specified by RIKEN KEIKI : BARRIERTA JFE 552 (manufactured by NOK KLUBER)  
If you can not prepare the specified grease, use one that meets the following requirements.
  1. Material does not harden due to deterioration
  2. Volatile solvent-free
  3. Material does not cause corrosion at the surface
  4. Silicon-free
  5. Validation of suitability depends on the specifications of grease manufacturer

## 4-5. Installation procedure

### <Attaching External Cable>

#### 【Export Specification】

The export specification comes with adapter A (NPT 1/2) as standard. Please prepare the Ex cable gland that is suitable for the adapter

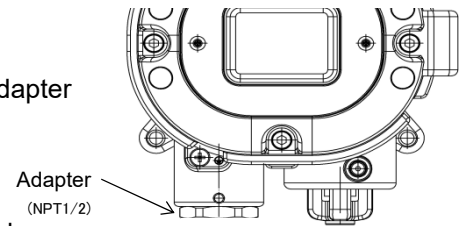

#### 【Japan Specification】

Cable gland, Rubber seal, Washer and Eccentric washer are mounted on SD-1GH main body as shown below.

Attach the parts :

Pass a Cable (e.g. CVVS) through the Cable gland, Eccentric washer, Washer, and Rubber seal, and drawn into detector inside. (For wire methods, see "4-6 How to wire".) When installing the cable gland, make sure that there is no dust in cable gland mounting part, hexagon socket set screw, grounding screw, and the cable gland. Then apply grease specified by RIKEN KEIKI.

Tightens Cable gland, and then tightens hexagon socket set screw (M4×6), and fix cable gland.

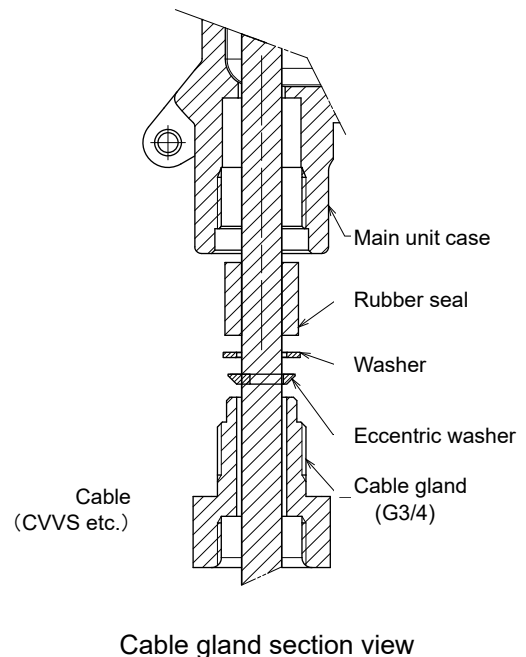
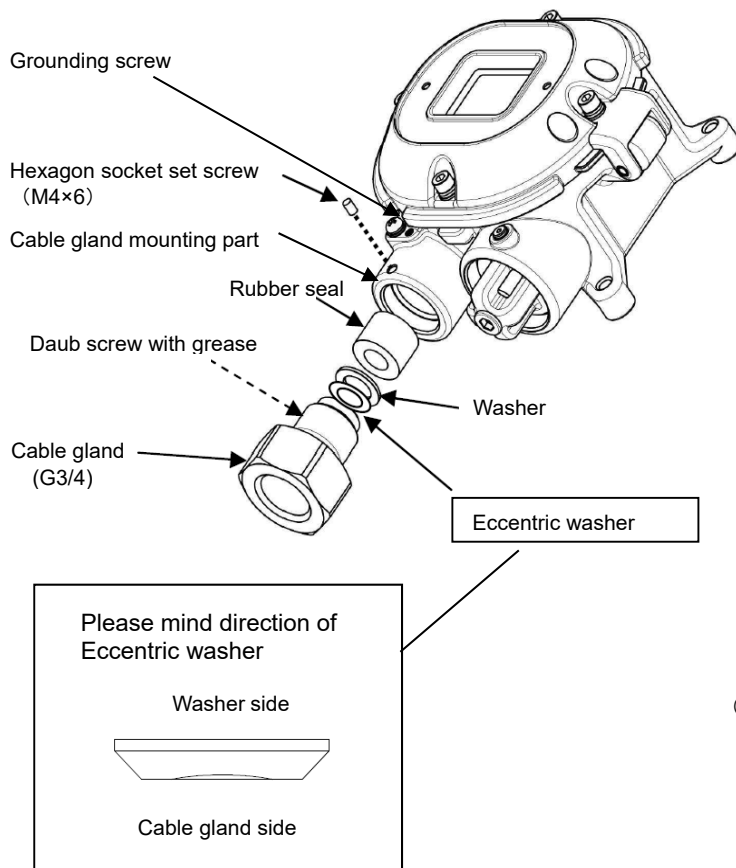

### WARNING

- Do not replace parts at your sole discretion but contact RIKEN KEIKI if the transparent window has a crack or the explosion-proof joint surface is abnormal, or the clamping screw or bolt is changed, lost etc.



### CAUTION

- Tighten 40 N·m or larger torque value to ensure the tightening cable gland and seal plug.
- Tighten the hexagon socket head cap screws fixing the cable gland with a tightening torque of 107.8 ±12.7N·m.

**NOTE**

---

- Our company-specified grease : BARRIERTA JFE 552 (manufactured by NOK KLUBER)  
If you can not prepare the specified grease, use one that meets the following requirements.
    1. Material does not harden due to deterioration
    2. Volatile solvent-free
    3. Material does not cause corrosion at the surface
    4. Silicon-free
    5. Validation of suitability depends on the specifications of grease manufacturer
-

## 4-6. How to wire



### CAUTION

- Be careful not to damage the internal electronic circuit when wiring. In addition, be careful not to apply stresses on the detector when (overweight) cables are installed.
- The power cables and signal cables must not be installed together with the motor power cables, etc. When these cables must be installed together for unavoidable reasons, put the power cables and signal cables in a metal conduit. The conduit must be connected to a grounding circuit.
- When stranded wires are used, prevent wires from contacting each other.
- Use the dedicated handling lever to wire.
- Use appropriate cables to wire.

### <Recommended Cable>

3-wire	CVVS 1.25 sq or 2.0 sq/3-core
4-wire	CVVS 1.25 sq or 2.0 sq/4-core

Cable overall outer diameter(mm)	Rubber seal inner diameter(mm)	Washer inner diameter(mm)
From $\Phi 9.6$ to less than $\Phi 11.0$	$\Phi 11$	$\Phi 12$
From $\Phi 11.0$ to less than $\Phi 11.5$	$\Phi 12$	$\Phi 12$
From $\Phi 11.5$ to less than $\Phi 12.0$	$\Phi 12$	$\Phi 14$
From $\Phi 12.0$ to less than $\Phi 13.0$	$\Phi 13$	$\Phi 14$
$\Phi 13.0$	$\Phi 13.5$	$\Phi 14$

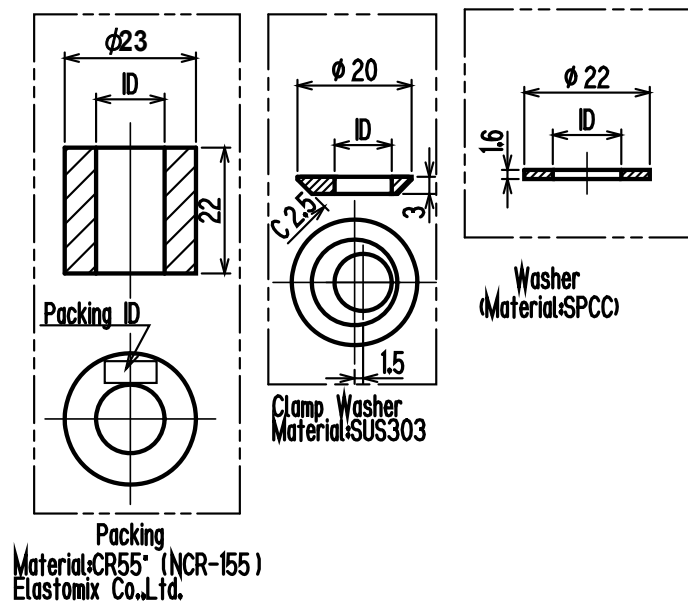

**NOTE**

- The following table shows an example of overall outer diameters of cables. Use them for reference. The overall outer diameters must be checked because they somewhat vary between manufacturers.

Number of core	CVV 1.25sq	CVV 2sq	CVVS 1.25sq	CVVS 2sq
2	Φ9.5	Φ10.5	Φ10.0	Φ11.0
3	Φ10.0	Φ11.0	Φ10.5	Φ11.5
4	Φ10.5	Φ11.5	Φ11.0	Φ12.0
5	Φ11.5	Φ12.5	Φ12.0	Φ13.0
6	Φ12.5	Φ13.5	Φ13.0	Φ14.0

<Figure of Terminal Plate>

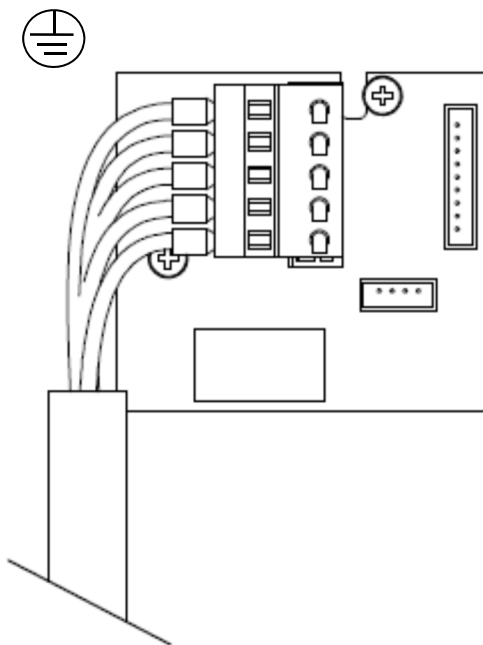

24 VDC	DC+	1
	DC-	2
4 - 20 mA	Sig+	3
	Sig-	4

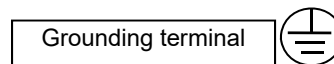

**NOTE**

If HART functions are not used, 2p of terminal plate is being deemed to be power and the 4-20mA output common (-) terminal, and using as 3-wire is possible.

<Specifications of Terminal Plate>

Specifications of terminal plate

- Rated voltage: 250 VAC
- Rated current: 12 A  
However, it depends on cables to be used.

Connection conditions

- Cables: 0.25 - 2.5 mm<sup>2</sup>
- Bare wire length: 8 - 9 mm
- Connecting tool: Dedicated handling lever (accessory) or driver (edge 3.5 x 0.5 mm)



## CAUTION

The specified bare wire length must be observed when the wire insulation is peeled off. Improper clamping of the wire due to a shorter bare wire length may cause defective electric conduction or heating. Catching the wire insulation due to a shorter bare wire length may cause defective electric conduction or heating. Exposing the wire due to a longer bare wire length may cause defective insulation or a short circuit. Be careful not to break up the wire. If the wire is broken up when inserted to the terminal, this may cause defective insulation or heating.

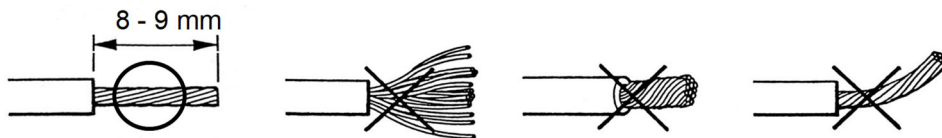

### Compatible bar terminal

For a bar terminal, the following items are available.

- Bar terminal (ferrule): Model 216 Series (manufactured by WAGO)
- Crimping tool: Model VarioCrimp 4 (206-204) (manufactured by WAGO)



## CAUTION

A bar terminal of the specified model must be used. Using other bar terminals invalidates the warranty of the performance.

### <How to Connect to Terminal Plate>

When cables are connected to the connectors, use the dedicated lever or a flathead screwdriver to do it as shown below.



## CAUTION

The right tools must be used. In principle, one wire can be connected to one wiring hole. When the wire is inserted into the driver slot by mistake, it does not contact the conductive part. This may cause defective electric conduction or heating. When the wire is inserted under the spring by mistake, it does not contact the conductive part. This may cause defective electric conduction or heating.

## NOTE

<How to Use the Dedicated Handling Lever>

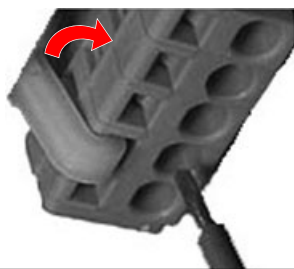

Push the lever with your finger to lower the spring in its inside.

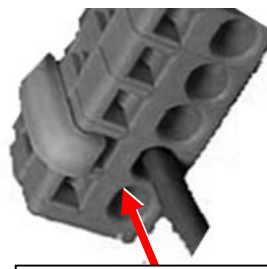

While holding down the lever, insert the wire into the (round) wiring hole until it reaches the deepest point. Once the lever is released, the wire is secured.

To check whether the wire is connected securely, pull the wire gently. (Do not pull the wire strongly.)

## &lt;Grounding&gt;

Connect the detector to your grounding terminal with the external terminal .

**WARNING**

- Before turning on the detector, do not forget to connect it to a grounding terminal.
- For stable operation of the detector and safety, it must be connected to a grounding terminal. Do not connect the grounding wire to a gas pipe.
- The grounding must be made as D type grounding (below 100  $\Omega$  of grounding resistance).
- For the grounding wire, use cable lugs to safely connect it to a grounding terminal without looseness or twist.
- Use ring terminals to connect the grounding terminal with the ground and use the grounding wire with cross-sectional area of 4 mm<sup>2</sup> or more for the external grounding terminal.

## &lt;Wiring Example&gt;

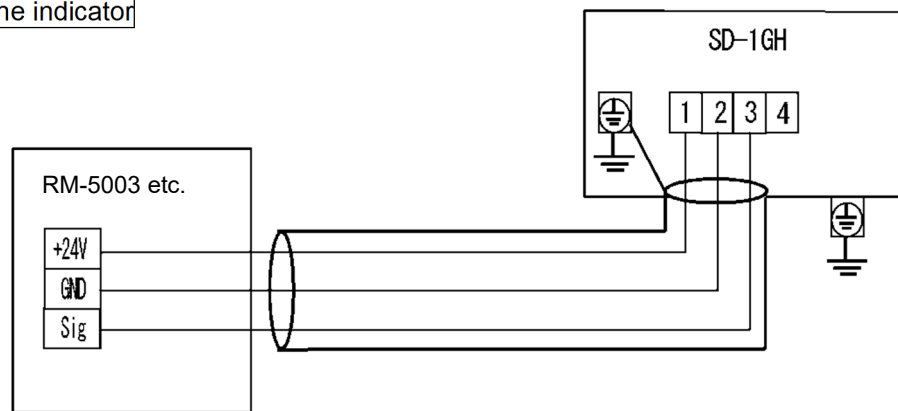
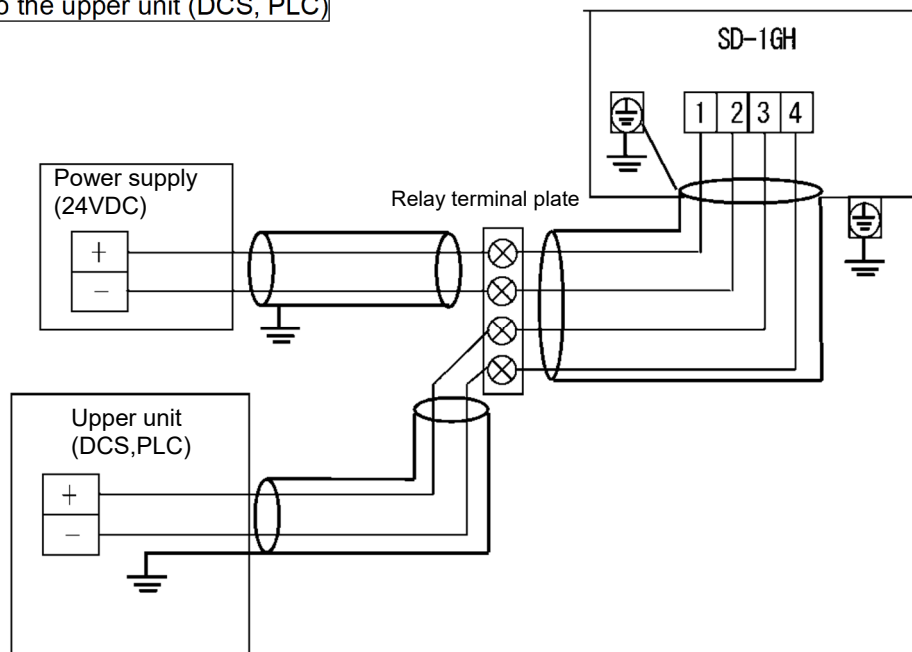
Connecting to the indicatorConnecting to the upper unit (DCS, PLC)**CAUTION**

If HART communication is used, check so that wiring load resistance that constitute 4-20mA loops, amount to 250  $\Omega$ -300  $\Omega$ .

5

# How to Operate

## 5-1. Preparation for start-up

Before supplying power, read and understand the following precautions. Ignoring these precautions may cause an electric shock or damage the detector.

- Connect the detector to a grounding circuit.
- Check that the wiring is connected to external device properly.
- Check that the power supply voltage is compliant with the specifications.

## 5-2. Basic operating procedures

Normally, the detection mode is used for normal operations. (The detection mode is activated after the power is turned on.)

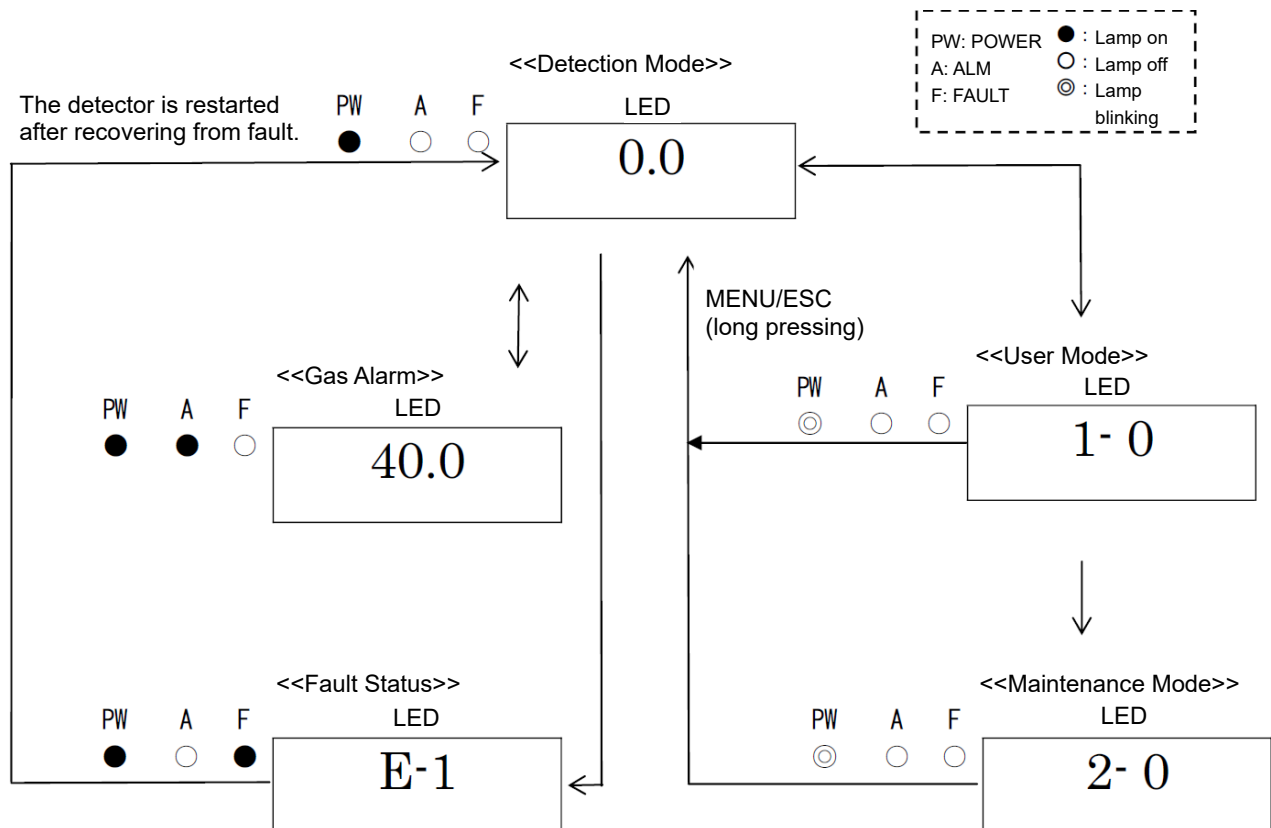





**WARNING**

When the detector enters other mode from the detection mode while an alarm is activated, the alarm is reset.

**5-3. How to start the detector**

- Before supplying power (24 VDC) to the detector, check that the detector is installed properly.
- Supply power (24 VDC) to the detector (turn on the detector).
- After the detector completes the start-up, it enters the detection mode swiftly.



**CAUTION**

- Do not turn off the detector during the initial clear. The detector is reading the internal memory during the initial clear.
- If the detector is installed newly or the new sensor is replaced, the sensor must be warmed up for a specified period which is determined depending on the type of the sensor after the detector is started.
- After the warm-up is completed, perform a gas calibration.

**NOTE**

<<Start-up Operation Procedures>> (approximately 25 seconds for system check of the detector and alarm deactivation)

Power on -> Initial clear (approximately 25 seconds) -> Detection mode

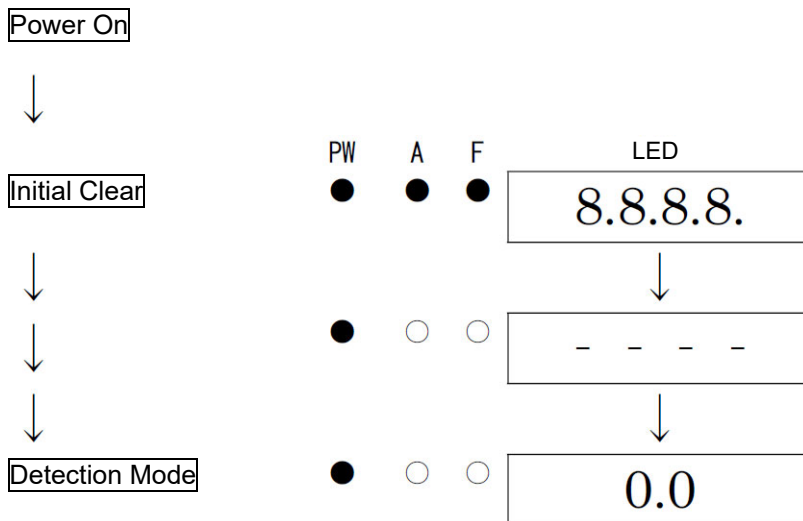

**NOTE**

The semiconductor sensor used in the detector must be warmed up for a specified warm-up (powered) time after power is supplied. The required warm-up (powered) time depends on the unpowered time for the sensor. The time shown in the table shown below must be met.

Unpowered time	Guidelines for warm-up (powered) time
24 hours or less	4 hours or more
72 hours or less	24 hours or more
10 days or less	2 days or more
Less than 1 month	7 days or more
Less than 3 month	14 days or more
3 months or more	1 month or more

## 5-4. Modes

Details on each mode are provided as follows.



### CAUTION

- Do not change the settings if not necessary. Changing the settings without understanding the specifications may cause malfunctions.

Mode	Item	LED display	Details
Detection Mode		Gas concentration	Normal state
Maintenance Mode (user mode)	ROM/SUM Display	1-0	Show the program version and others. This is not typically used by the user.
	Zero Adjustment	1-1	Perform the zero adjustment.
	Setting Display	1-2	Show various setting values.
	Switch to Maintenance Mode	1-3	Switch to the regular maintenance mode.
Maintenance Mode (regular maintenance mode)	Test Mode	2-0	Perform various tests. 2-0.0 Gas Test 2-0.1 Alarm Test 2-0.2 Fault Test 2-0.3 LED Test 2-0.4 Memory Test
	Zero Adjustment	2-1	Perform the zero adjustment.
	Span Adjustment	2-2	Perform the span adjustment.
	Zero/Span Initialization	2-3	Initialize zero/span values.
	Environmental Setting	2-4	Used for various environmental settings. 2-4.0 Sensor Power Supply ON/OFF 2-4.1 INHIBIT Setting 2-4.2 Alarm Setpoint Setting 2-4.3 Alarm Delay Time Setting 2-4.4 Alarm Pattern Setting 2-4.5 Zero Suppression Pattern Setting 2-4.6 Zero Suppression Value Setting 2-4.7 Not used. 2-4.8 Not used. 2-4.9 Zero Follower Selection 2-4.A Maintenance Mode External Output Setting 2-4.B External Output Adjustment 2-4.C Alarm Test External Output Setting 2-4.D Sensor Operation Start Setting 2-4.E Password Setting 2-4.F Sensor Fault Alarm Pattern Setting 2-4.H LOAD Voltage Adjustment
	Display	2-5	Display various electrical settings. This is not typically used by the user.
	Switch to Factory Mode	2-6	Not used.
	Switch to User Mode	2-7	Returns to the user mode.

## 5-5. User mode



### WARNING

After the adjustment is completed, never fail to press MENU/ESC key to return to the detection mode.  
 (If the detector remains in the user mode, it automatically returns to the detection mode in ten hours.)

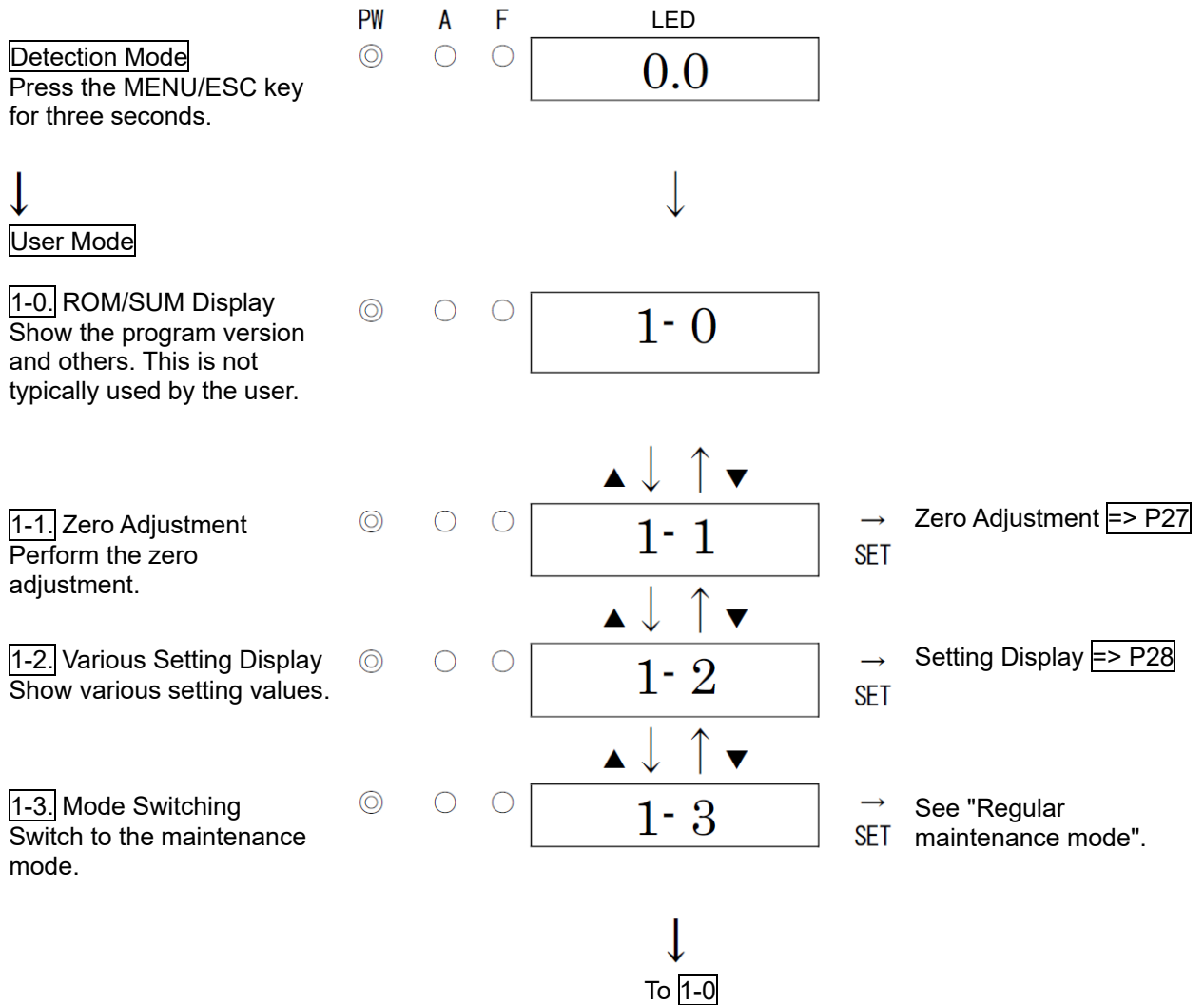

## <Zero Adjustment "1-1">

This is used to perform the zero adjustment.



**WARNING**

When a gas calibration is performed, always perform both the zero adjustment and the span adjustment. Perform the zero adjustment and the span adjustment in this order. If they are performed in a wrong order or only one of them is performed, accurate gas detection cannot be ensured.

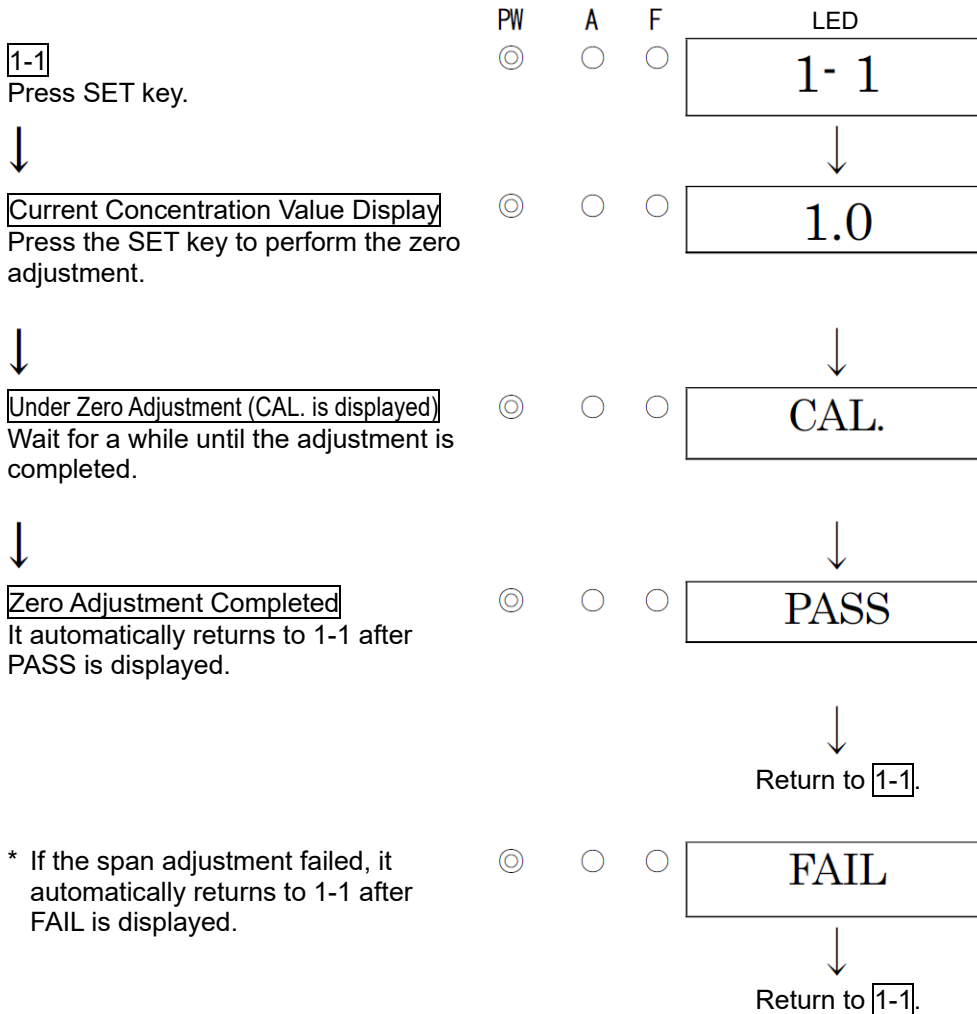

### NOTE

- If the zero calibration failed since the zero point was significantly fluctuated from around zero, it returns to 1-1 after FAIL rather than PASS is displayed. In this case, the zero adjustment has not been completed.

### <Setting Display "1-2">

Show various setting values.

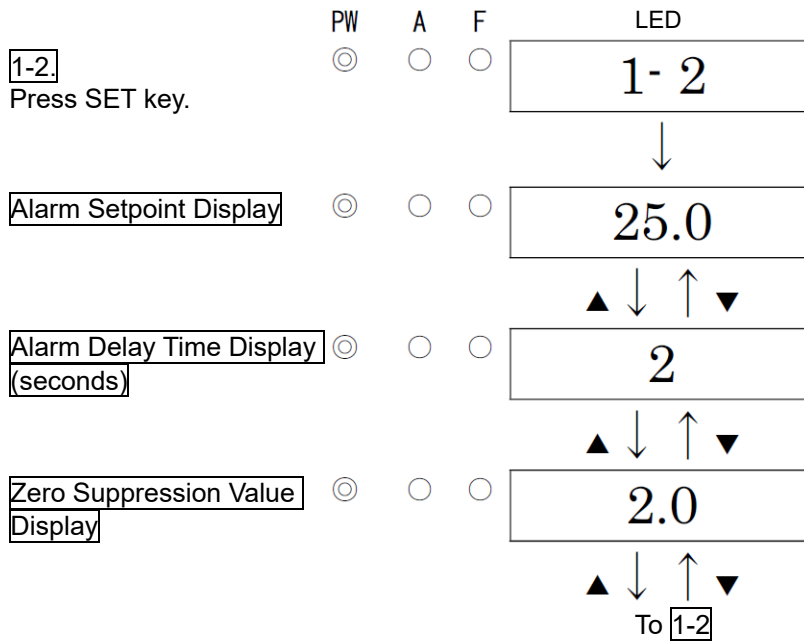

## 5-6. How to exit

To turn off the detector, turn off the power supply (24 VDC) to the detector.



**WARNING**

- When the detector is turned off, an alarm may be triggered on the upper (central) system.
- Before turning off the detector, INHIBIT (point skip) on the upper (central) system must be activated. Decide whether the power can be turned off by checking the operation of the devices connected to the external output terminal of the detector.

## 6

# Operations and Functions

## 6-1. Gas alarm activation

Gas alarm: Triggered when the concentration of detected gas reaches or exceeds the alarm setpoint value. <<Auto-Reset>>

### NOTE

The alarm setpoint is factory-set. Although the alarm delay time (standard: 2 seconds) works in the detector to prevent a false activation, it can be cancelled if not needed.

### <Display Operation>

#### Gas Concentration Display

In case of over the detection range (Over Scale), "〇〇〇〇" is displayed on the LED.

#### Power Indicator Lamp (POWER: Green)

During operation, this lights up continuously.

#### Alarm Indicator Lamp (ALM: Red)

It lights up when the alarm setpoint value is reached to or exceeded.

### <Alarm Activation>

It lights up when the gas concentration reaches or exceeds the alarm setpoint value. (only when the alarm is used)

The alarm activation is reset automatically when the gas concentration drops below the alarm setpoint value.

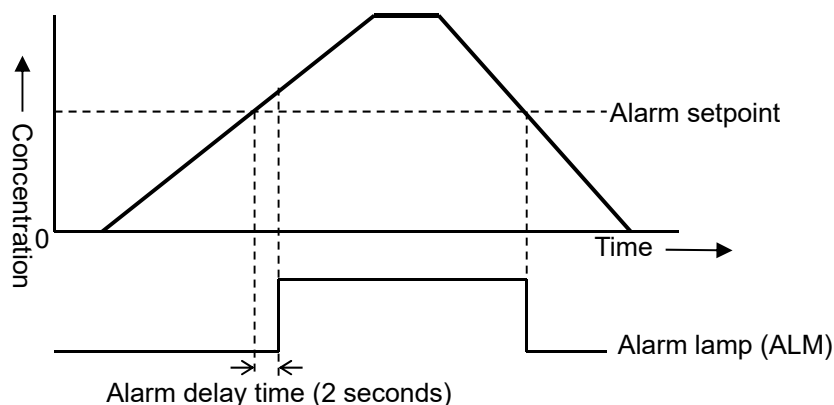

## <Response to Gas Alarm>

A gas concentration value exceeds the alarm setpoint

When a gas alarm is triggered, take actions in accordance with your management rules of gas alarm. Normally, take the following actions.

- Check the reading of the detector.

### NOTE

If a gas leak is momentary, the reading may already have dropped when checking it. In addition, when the alarm is triggered by noise or other incidental conditions other than a gas, the reading may have already dropped.

- Based on your management rules of gas alarm, no one can be allowed to access the monitored zone to ensure safety.
- If the gas concentration display continues to be displayed, close the main valve of the gas, and then check that the gas concentration reading dropped.
- Access the gas leak point, equipped with a protective gear to avoid dangers caused by possibly remaining gases, and check whether gases remain or not by using a portable gas detector.
- Check that the point is free from dangers, and take actions to fix the gas leak.

## 6-2. Fault alarm activation

A fault alarm is triggered when the detector detects abnormalities. After a fault alarm is triggered, the fault lamp (yellow) lights up and an error message is displayed on the LED. Determine the causes and take appropriate actions.

After the detector is successfully returned from the fault, it restarts with the process normally performed right after it is turned on (initial clear).

If the detector has problems and is repeatedly malfunctioning, contact RIKEN KEIKI immediately.

### NOTE

For information on malfunctions (error messages), see "9. Troubleshooting".



## 6-3. External output operation

Signal Transmission System		Electric current transmission (non-isolated) 4 – 20 mA
Transmission Path		CVVS
Transmission Distance		CVVS 1.25 sq: Maximum 1 km
Connection Load Resistance		Below 300 $\Omega$
1	Detection Mode (No Alarm)	4 - 20 mA (concentration output)
2	Detection Mode (Gas Alarm)	4 - 20 mA (concentration output)
3	Initial Clear	Depending on the setting of section 4. <u>2.5 mA setting</u> : 2.5 mA <u>4 mA, HOLD, 4 - 20 mA setting</u> : 4 mA
4	Maintenance Mode	<u>2.5 mA setting</u> : 2.5 mA <u>4 mA setting</u> : 4 mA <u>HOLD setting</u> : The previous value retained <u>4 - 20 mA setting</u> : 4 - 20 mA (concentration output)
5	Alarm Test	<u>Output ON setting</u> : 4 - 20 mA (concentration output) <u>Output OFF setting</u> : 4 mA
6	Fault Alarm	0.5 mA (Fixed)
7	INHIBIT	Depending on the setting of section 4. <u>2.5 mA setting</u> : 2.5 mA <u>4 mA, HOLD, 4 - 20 mA setting</u> : 4 mA
8	Power Off	0 mA

### Example of Gas Concentration and External Output

4 - 20 mA specification  
(Maintenance output: 2.5 mA setting)

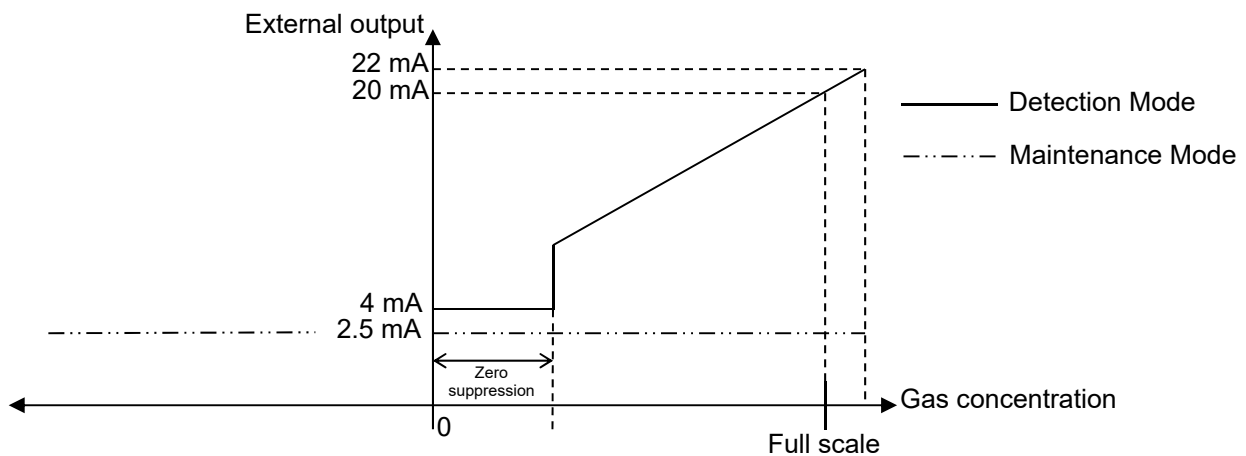

### CAUTION

- The 4 - 20 mA output is already adjusted. In case of over scale, an output will not exceed 22 mA.
- Output during INHIBIT or initial clear is based on 4 - 20 mA output setting in the maintenance mode.

In particular, when the detector is started or the specification is changed, be careful about 4-20 mA output setting. Understand how the detector functions, and take actions, if necessary, so that the signal receiver side can prepare to avoid false alarms.

## 6-4. Other functions

### <Suppression Function>

The sensors used with the detector are influenced by environmental changes (temperature, humidity, and other characteristics) or interference gases (interference characteristics) in no small measure, which affects the reading. Therefore, the reading might be fluctuated around zero even in a normal environment.

This function obscures influences by environmental changes and interference gases around zero that have no meaning for your management rules of gas alarm. This function is used to hide (suppress) the fluctuation of the reading under the setting value, indicating zero.

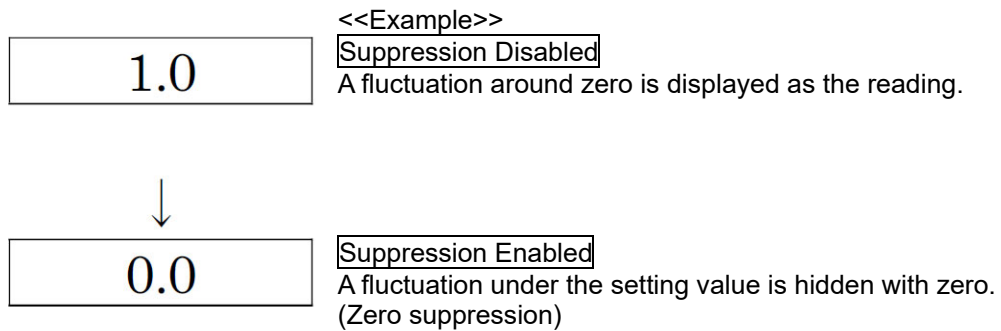

#### NOTE

- The suppression function is factory-set. The standard setting value is 10% FS.
- In the maintenance mode, this function is disabled and the fluctuation of the reading under the setting value is displayed.



#### CAUTION

A reading under zero is suppressed with the 10% FS suppression.

A reading that is 10% FS or more under zero is displayed as "-0.0", which prevents an accurate gas detection and needs the zero adjustment and span adjustment.

---

# 7

---

## Maintenance

The detector is an important instrument for the purpose of safety. To maintain the performance of the detector and improve the reliability of safety, perform a regular maintenance.

### 7-1. Maintenance intervals and items

- Daily maintenance: Perform a maintenance before beginning to work.
- Monthly maintenance: Perform maintenance on the alarm circuit (alarm test) once a month.
- Regular maintenance: Perform maintenance once or more for every six months to maintain the performance as a safety unit.

Maintenance item	Maintenance content	Daily maintenance	Monthly maintenance	Regular maintenance
Power Supply Check	Check that the power lamp lights up.	○	○	○
Concentration Display Check	Check that the concentration display value is zero. When the reading is incorrect, perform the zero adjustment and span adjustment after ensuring that no other gases exist around it.	○	○	○
Alarm Test	Inspect the alarm circuit by using the alarm test function.	-	○	○
Span Adjustment	Perform the span adjustment by using the calibration gas.	-	-	○
Gas Alarm Check	Check the gas alarm by using the calibration gas.	-	-	○

## <About Maintenance Services>

- We provide services on regular maintenance including span adjustment, other adjustments and maintenance.  
To make the calibration gas, dedicated tools, such as a gas cylinder of the specified concentration and gas sampling bag must be used.  
Our qualified service engineers have expertise and knowledge on the dedicated tools used for services, along with other products. To maintain the safety operation of the detector, please use our maintenance service.
- The followings are typical maintenance services. For more information, please contact RIKEN KEIKI.

### Main Services

Power Supply Check	:	Checks the power supply voltage. Verifies that the power lamp lights up. (Verifies that relevant points can be identified on the system.) (When a UPS (uninterruptible power system) is used, checks the operation with the UPS.)
Concentration Display Check	:	Verifies that the concentration display value is zero (or 20.9 vol% on the oxygen deficiency meter) by using the zero gas. Performs the zero adjustment (fresh air adjustment) if the reading is incorrect.
Flow Rate Check	:	Checks the flow rate indicator to find abnormalities. Checks the flow rate by using an external flow meter to verify the correctness of the flow rate indicator on the detector. If the flow rate is incorrect, performs the flow rate adjustment.
Filter Check	:	Checks the dust filter for dust or clogging. Replaces a dirty or clogged dust filter.
Alarm Test	:	Inspects the alarm circuit by using the alarm test function. <ul style="list-style-type: none"> <li>• Checks the alarm lamps. (Checks each activation of ALM1 and ALM2.)</li> <li>• Checks the external alarm. (Checks the activation of the external alarm, such as a buzzer.)</li> </ul>
Span Adjustment	:	Performs the span adjustment by using the calibration gas.
Gas Alarm Check	:	Checks the gas alarm by using the calibration gas. <ul style="list-style-type: none"> <li>• Checks the alarm. (Checks the alarm activation when the alarm setpoint is reached.)</li> <li>• Checks the delay time. (Checks time to delay until the alarm is triggered.)</li> <li>• Checks the alarm lamps. (Checks each activation of ALM1 and ALM2.)</li> <li>• Checks the external alarm. (Checks the activation of external alarms, such as a buzzer and reset signal.)</li> </ul>
Cleaning and Repair of Detector (visual diagnosis)	:	Checks dust or damage on surface, cover, or internal parts of the detector, clean and repair such parts of the detector. Replaces parts which are cracked or damaged.
Detector Operation Check	:	Uses the keys to check the operation of functions and parameters.
Replacement of Consumable Parts	:	Replaces consumable parts, such as a sensor, filter and pump.

## 7-2. Regular maintenance mode



### WARNING

After the adjustment is completed, never fail to press MENU/ESC key to return to the detection mode.

(If the detector remains in the regular maintenance mode, it automatically returns to the detection mode in ten hours.)

Mode	Item	LED display	Details
Maintenance Mode (regular maintenance mode)	Test Mode	2-0	Perform various tests. 2-0.0 Gas Test 2-0.1 Alarm Test 2-0.2 Fault Test 2-0.3 LED Test 2-0.4 Memory Test
	Zero Adjustment	2-1	Perform the zero adjustment.
	Span Adjustment	2-2	Perform the span adjustment.
	Zero/Span Initialization	2-3	Initialize zero/span values.
	Environmental Setting	2-4	Used for various environmental settings. 2-4.0 Sensor Power Supply ON/OFF 2-4.1 INHIBIT Setting 2-4.2 Alarm Setpoint Setting 2-4.3 Alarm Delay Time Setting 2-4.4 Alarm Pattern Setting 2-4.5 Zero Suppression Pattern Setting 2-4.6 Zero Suppression Value Setting 2-4.7 Not used. 2-4.8 Not used. 2-4.9 Zero Follower Selection 2-4.A Maintenance Mode External Output Setting 2-4.B External Output Adjustment 2-4.C Alarm Test External Output Setting 2-4.D Sensor Operation Start Setting 2-4.E Password Setting 2-4.F Sensor Fault Alarm Pattern Setting 2-4.H LOAD Voltage Adjustment
	Display	2-5	Display various electrical settings. This is not typically used by the user.
	Switch to Factory Mode	2-6	Not used.
	Switch to User Mode	2-7	Returns to the user mode.

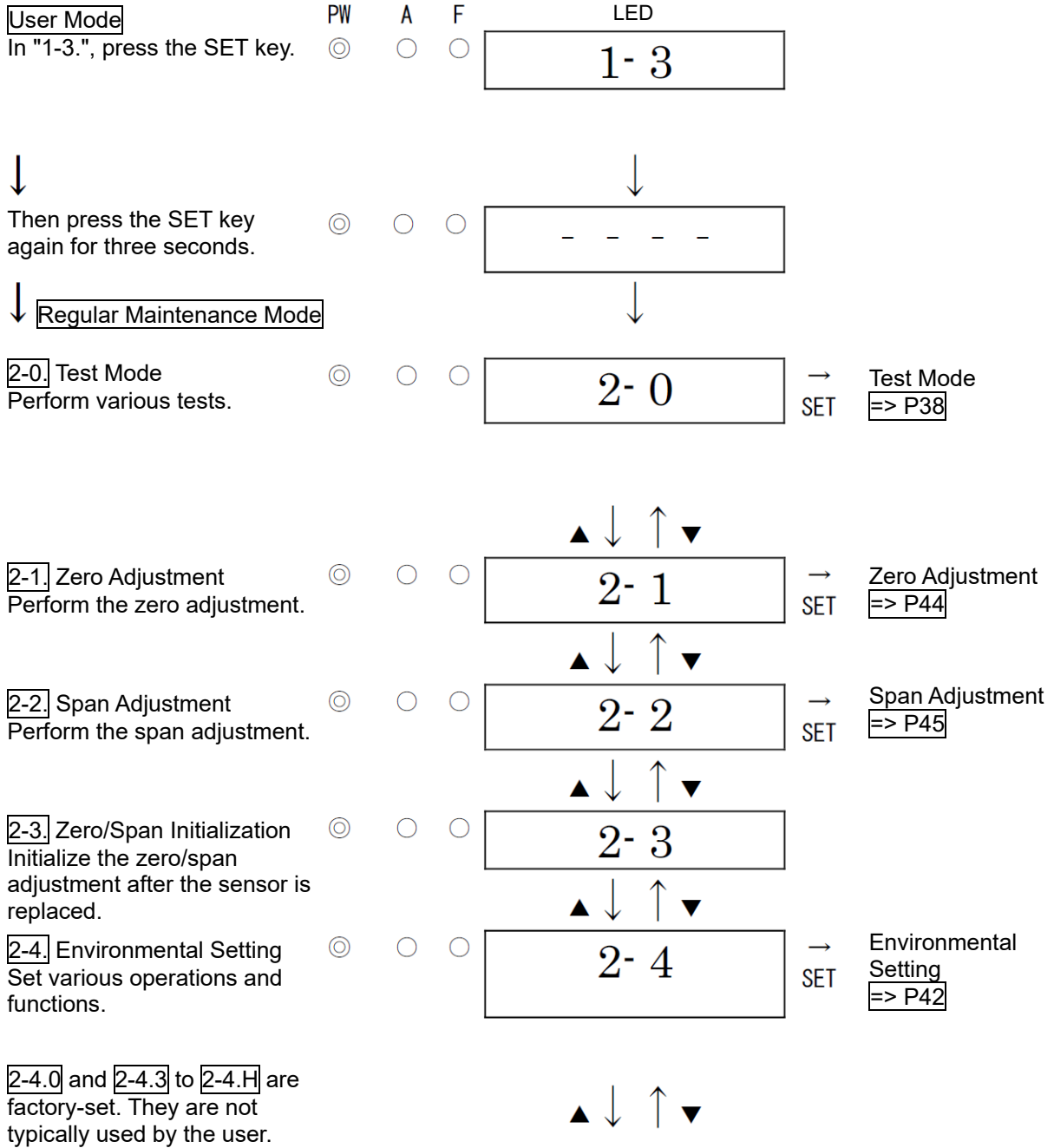

**2-5.** Various Electrical Settings Display  
Display various electrical settings. This is not used by the user.



2-5

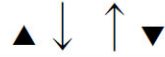

**2-6.**  
Enter the factory mode. This is not used by the user.



2-6

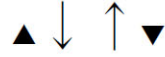

**2-7.**  
Return to the user mode.



2-7

→  
SET

rET. is displayed. Press the SET key again to return to the user mode.



To **2-0.** Test Mode

<Test Mode "2-0">

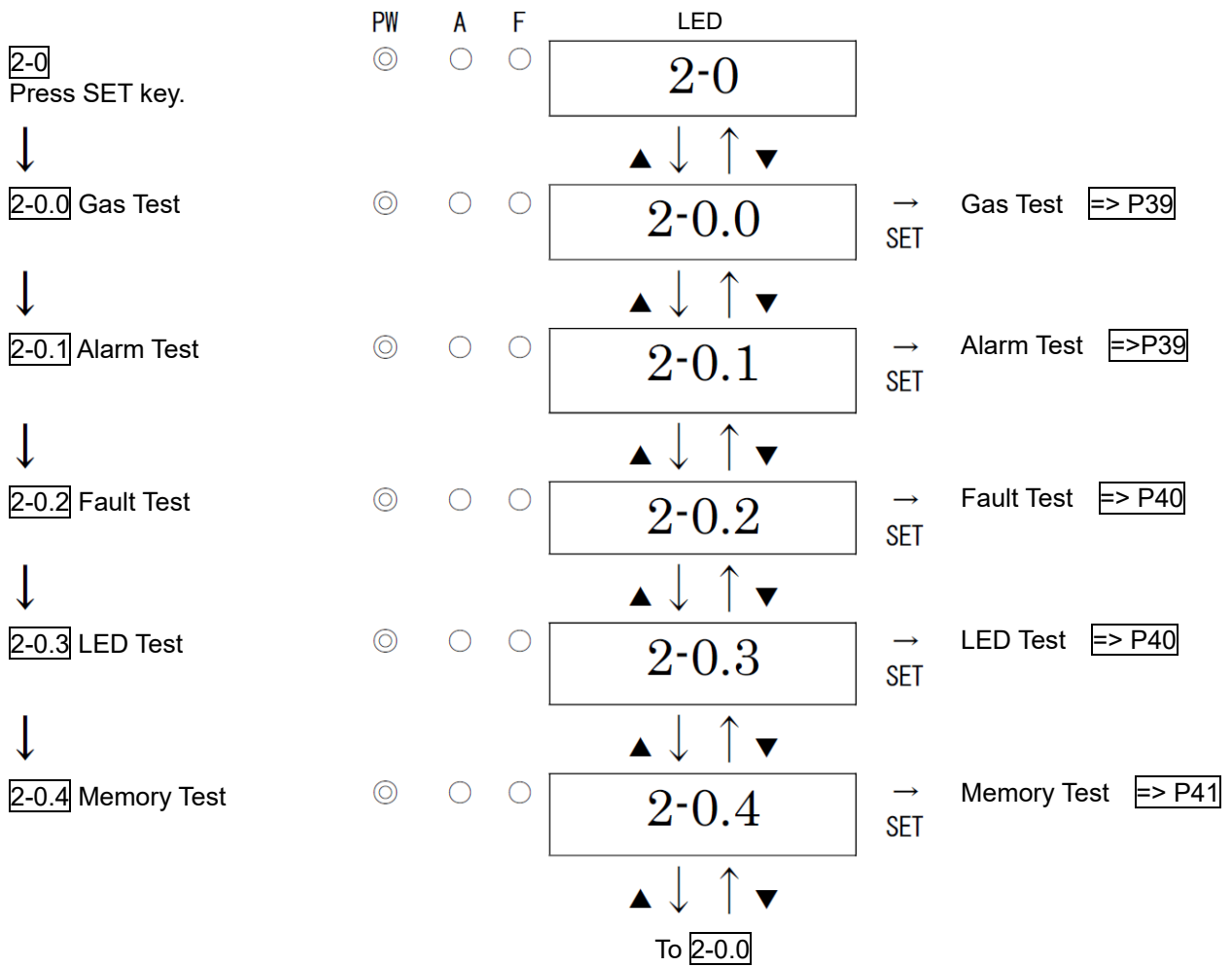



 **WARNING**

- Before starting the alarm test (transmission test), provide a notification to the related sections so that they can prepare for false abnormalities (external output signals). After the test is completed, never fail to press MENU/ESC key to return to the detection mode. (If the detector remains in the alarm test mode, it automatically returns to the detection mode in ten hours.)
- In the alarm test mode, the gas concentration equal to the reading is output even in the maintenance mode depending on the setting. Take actions, if necessary, so that the signal receiver side can prepare to avoid false alarms.

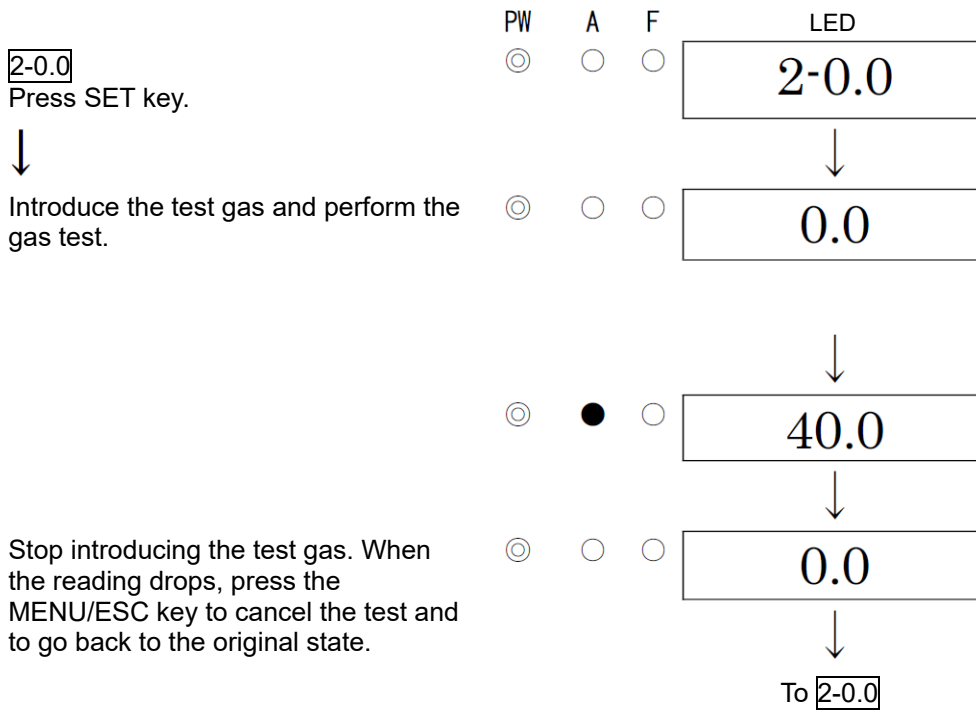

<Gas Test "2-0.0">







**WARNING**

Because the gas concentration output can be activated by a gas test even in the maintenance mode depending on setting, be careful to perform the test.

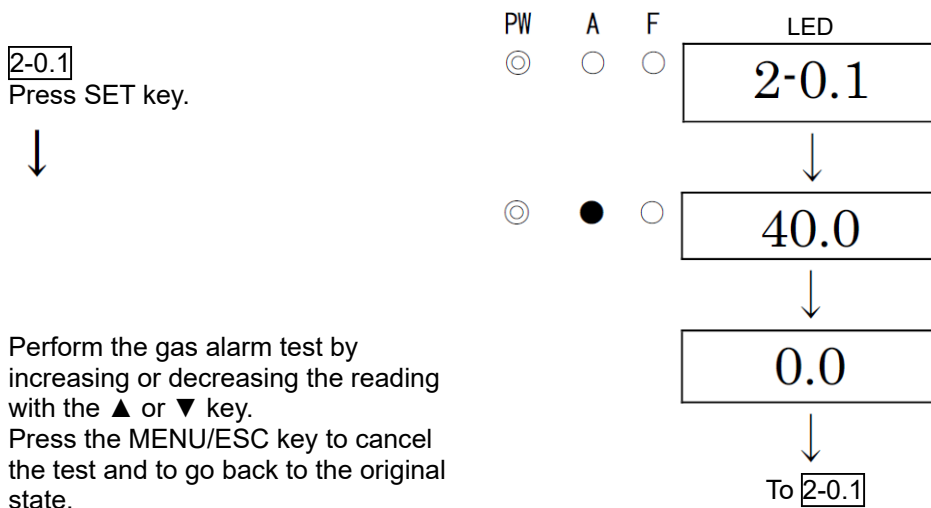
<Alarm Test "2-0.1">





**WARNING**

Because the gas concentration output can be activated by an alarm test even in the maintenance mode depending on setting, be careful to perform the test.

<Fault Test "2-0.2">

**2-0.2**

Press SET key.



**Fault Test ON/OFF**

Select either ON/OFF.

Switch ON and press the SET key to trigger the fault alarm.

Return to OFF and press the SET key to cancel the test.

(Pressing the MENU/ESC key also enables to cancel the test and to go back to the original state.)

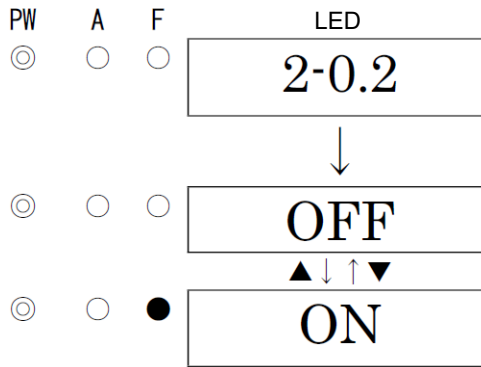

**WARNING**

Because the gas concentration output can be activated by a fault test even in the maintenance mode depending on setting, be careful to perform the test.

<LED Test "2-0.3">

**2-0.3**

Press SET key.



**LED Test ON/OFF**

Select either ON/OFF.

Switch ON and press the SET key to turn on the LEDs (POWER, ALM, FAULT) and to display the gas concentration of 8.8.8.8.

Return to OFF and press the SET key to cancel the test.

(Pressing the MENU/ESC key also enables to cancel the test and to go back to the original state.)

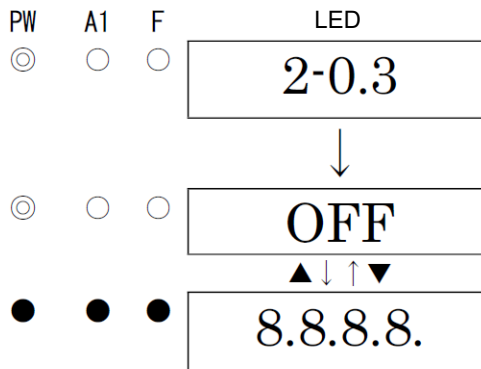

<Memory Test "2-0.4">

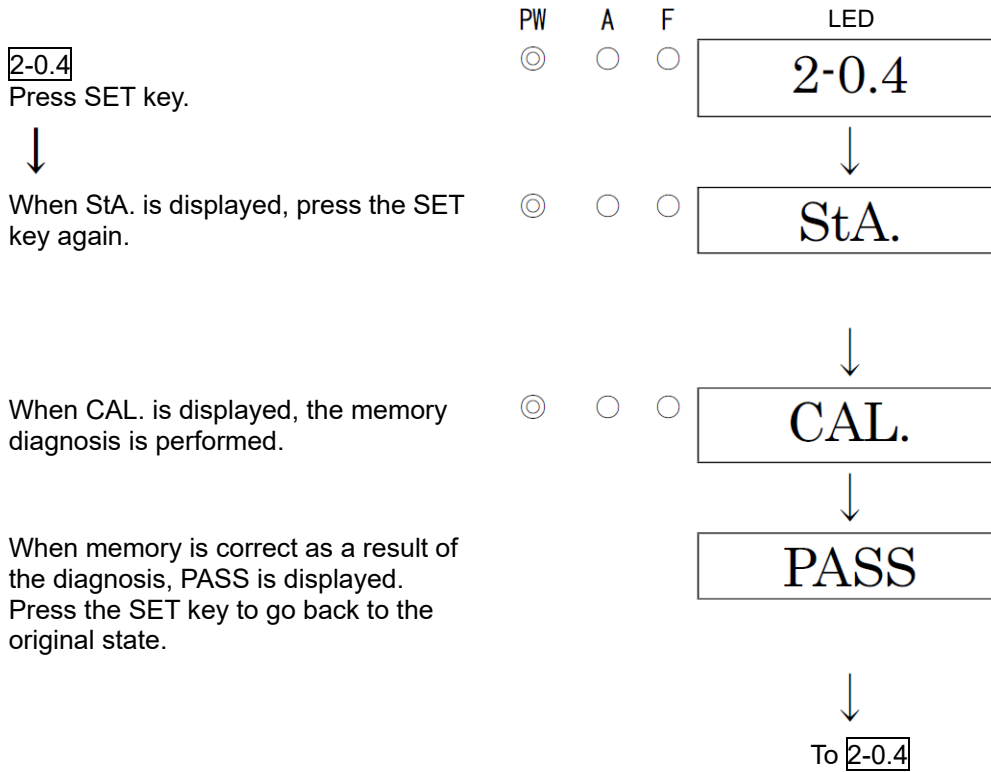

**NOTE**

When abnormalities are found in memory as a result of the diagnosis, PASS is not displayed. F-RA is displayed for the RAM fault, and F-RO is displayed for the ROM fault. For both the RAM fault and ROM fault, F-RA and F-RO are displayed alternately.

### <Environmental Setting "2-4">

Set various operations and functions in the environmental setting.

<<Environmental Setting 1>>	PW	A1	F	LED
<u>2-4.</u> Environmental Setting	<input checked="" type="radio"/>	<input type="radio"/>	<input type="radio"/>	2- 4
Press SET key.				

↓	↓
<u>2-4.0</u>	2-4.0
They are factory-set and not typically used by the user.	

<u>2-4.1</u> INHIBIT Setting	<input checked="" type="radio"/>	<input type="radio"/>	<input type="radio"/>	2-4.1	↔	OFF
Set Inhibit.					SET	▲↓↑▼
Select either ON/OFF, and then press the SET key to confirm the selection.						ON
When ON is selected, in the detection mode <u>InHi</u> , and <u>0.0</u> (gas concentration value) are displayed on the LED alternately. As a result, an alarm is not triggered to external device.				▲     ▼		
				↓     ↑		

<u>2-4.2</u> Alarm Setpoint Setting	<input checked="" type="radio"/>	<input type="radio"/>	<input type="radio"/>	2-4.2	↔	Alarm Setpoint Setting
Set the alarm setpoint.					SET	=> P42

<u>2-4.3</u> to <u>2-4.H</u>	<input checked="" type="radio"/>	<input type="radio"/>	<input type="radio"/>	2-4.3~2-4.H
They are factory-set and not typically used by the user.				
				▲↓↑▼
				To <u>2-4.0</u>

### <Alarm Setpoint Setting "2-4.2">

<u>2-4.2</u>	PW	A	F	LED
Press SET key.	<input checked="" type="radio"/>	<input type="radio"/>	<input type="radio"/>	2-4.2

↓	↓
<u>Alarm Setpoint Setting</u>	25.0
Select the number by pressing the ▲ or ▼ key, and then press the SET key to confirm the value. (Press the MENU/ESC key to go back to the original state.)	
	Return to <u>2-4.2</u> .

## 7-3. Gas calibration method

Perform a gas calibration in each mode (zero adjustment mode and span adjustment mode) using the calibration gas.

- Zero adjustment gas
- Span adjustment gas (collected in a gas sampling bag)
- Gas sampling bags

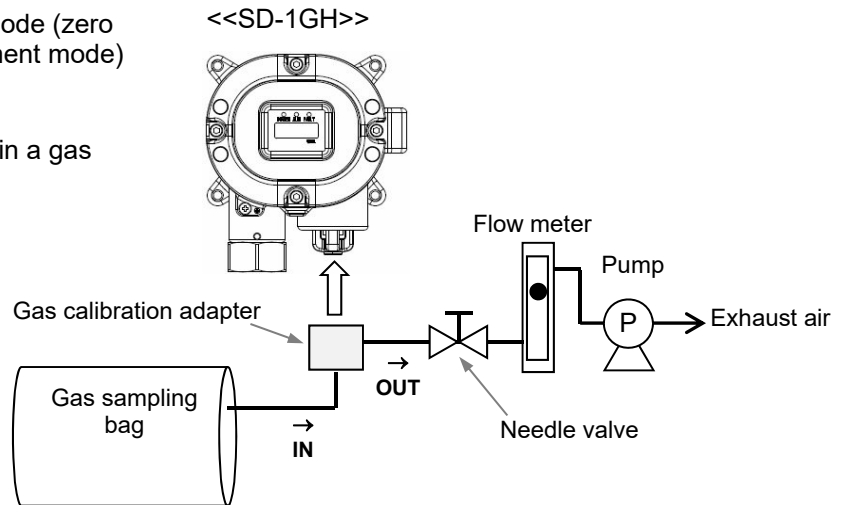

### WARNING

When a gas calibration is performed, always perform both the zero adjustment and the span adjustment. Perform the zero adjustment and the span adjustment in this order. If they are performed in a wrong order or only one of them is performed, accurate gas detection cannot be ensured.

## <Zero Adjustment "2-1">

This is used to perform the zero adjustment.



### WARNING

When the zero adjustment is performed in the atmosphere, check the atmosphere for freshness before beginning the adjustment. If other gases exist, the adjustment cannot be performed properly, thus leading to dangers when the gas leaks.

### NOTE

- Before starting the zero adjustment, provide the detector with the zero adjustment gas and wait until the indicator is stabilized.

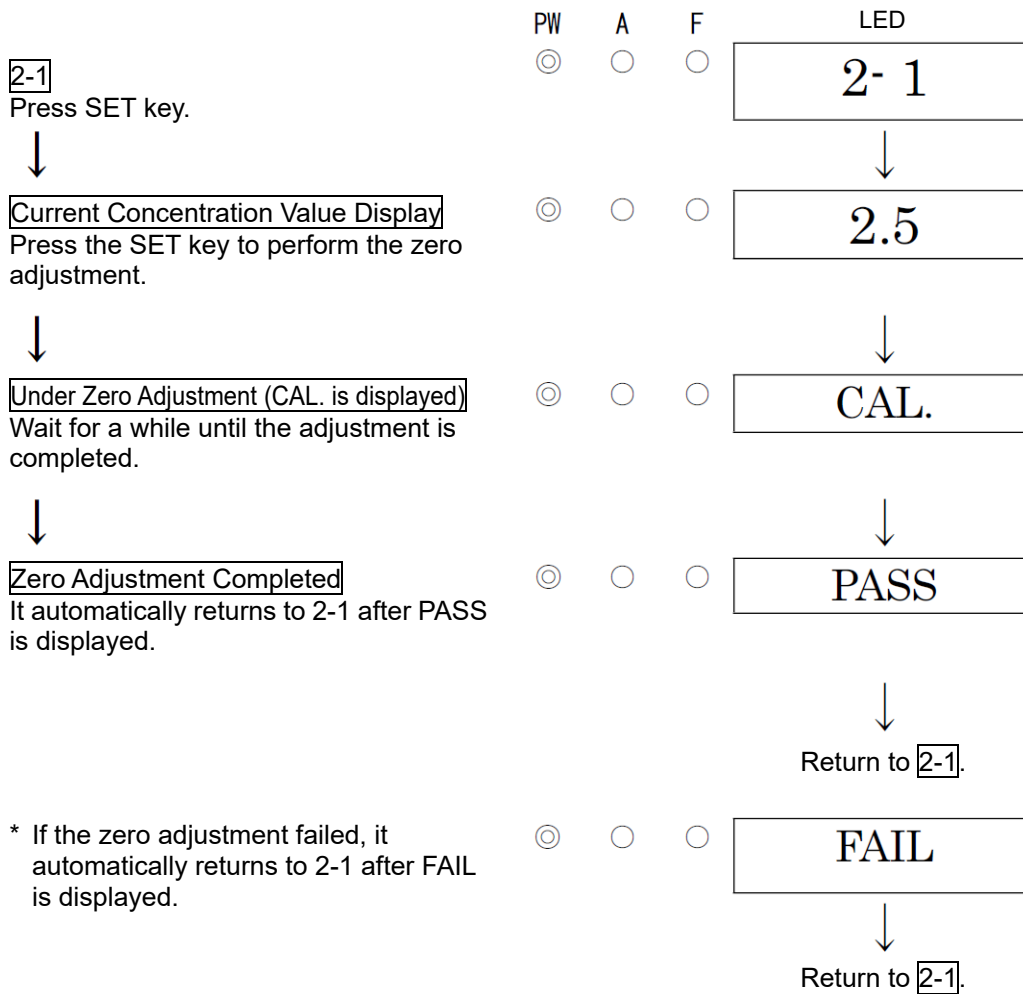

### NOTE

- If the zero calibration failed since the zero point was significantly fluctuated from around zero, it returns to 2-1 after FAIL rather than PASS is displayed. In this case, the zero adjustment has not been completed.

## <Span Adjustment "2-2">

This is used to perform the span adjustment.



### CAUTION

- Before starting the span adjustment, provide the detector with the span adjustment gas and wait until the indicator is stabilized.

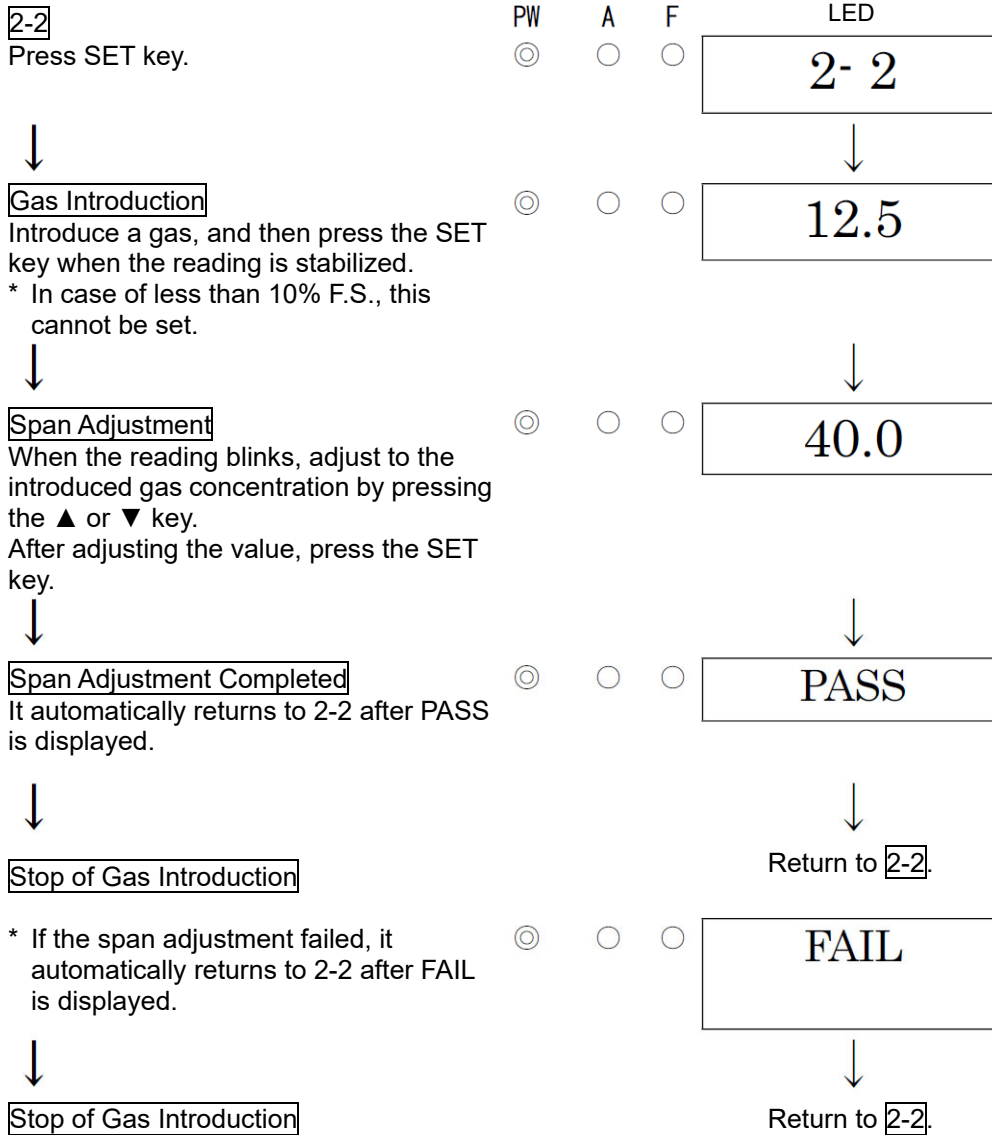

### NOTE

- If the span adjustment failed since the reading was significantly fluctuated from the introduced gas concentration, it returns to 2-2 after FAIL rather than PASS is displayed . In this case, the span adjustment has not been completed.  
Check if the correct concentration span adjustment gas has been provided and check the gas adjustment tool for a gas leak. If there are mistakes, perform the span adjustment again.  
If the span adjustment cannot be performed even when there is no mistake or after recalibration, the gas sensor life might have expired. After turning off the power supply, please contact RIKEN KEIKI.

## 7-4. Parts replacement

### <Sensor Replacement>

Gas sensor replacement is according to the following procedures.

- (1) Turn off the power supply (24VDC) to the detector.
- (2) After loosened set screw by hex wrench (nominal size 2), remove sensor guard by hex wrench (nominal size 6).
- (3) Remove the sensor. Pinch top of sensor (sintered metal portion) by using finger, and pull out it.
- (4) Mount a new sensor. There are five pins for sensor, but a pin is longer than the others to show the reference, and equip detection unit with sensor. When put on the sensor, do NOT scratch mating portion of side of the sensor and adapter inside.
- (5) After replacing a sensor, put on a sensor guard and set screw firmly. When installing the sensor guard, make sure that the guard mounting part, set screw, and sensor guard are free of dust, and apply grease specified by RIKEN KEIKI.
- (6) After sensor replacement, turn on the power and warm – up, then do the zero - point adjustment and span adjustment by [7-3. Gas calibration method].

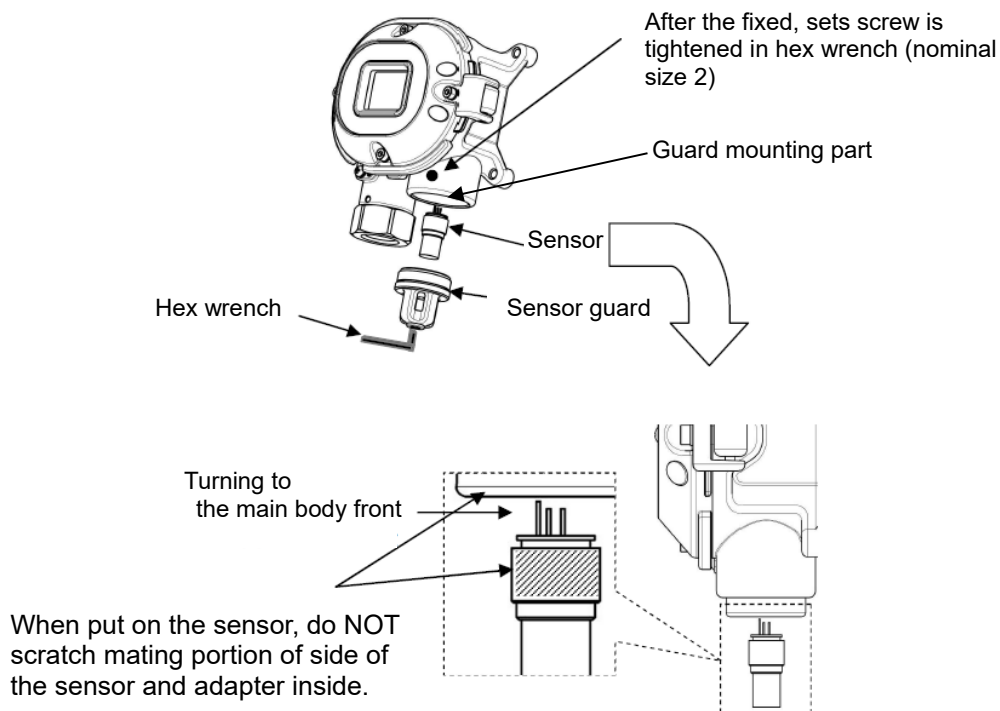



**NOTE**

- Tighten the set screw of the sensor guard at  $107.8 \pm 12.7\text{N} \cdot \text{cm}$ .
- The gas calibration using the standard gas is required after the sensor is replaced. Please request it to our overseas sales department or local representatives.
- Grease specified by RIKEN KEIKI : BARRIERTA JFE 552 (manufactured by NOK KLUBER)  
If you can not prepare the specified grease, use one that meets the following requirements.
  1. Material does not harden due to deterioration
  2. Volatile solvent-free
  3. Material does not cause corrosion at the surface
  4. Silicon-free
  5. Validation of suitability depends on the specifications of grease manufacturer

**WARNING**

- Do NOT exchange any parts while turn on electricity. It may happen fire.
- Turn off the power supply, and then replace parts.

**<Replacement of Regular Replacement Parts>**

List of recommended regular replacement parts

No.	Item	Maintenance intervals	Replacement intervals (year)	Quantity (pieces/unit)
1	Guard assembly	6 months	3 - 8 years	1

- ※ After replacements having need of operation check by professional service engineers.  
To maintain the safety operation of the detector, please use our maintenance service.  
Request RIKEN KEIKI for it.

**NOTE**

- The above replacement intervals are recommendation only. The intervals may change depending on the operating conditions. These intervals do not mean the warranty periods either. The result of the regular maintenance may determine when to replace the parts.

---

**8**

---

# Storage, Relocation and Disposal

## 8-1. Procedures to store the detector or leave it for a long time

The detector must be stored under the following environmental conditions.

- In a dark place under the normal temperature and humidity away from direct sunlight
- In a place where gases, solvents or vapors are not present

## 8-2. Procedures to relocate the detector or use it again

When the detector is relocated, select a new place in accordance with "4-2. Precautions for installation points" and "4-4. How to install".

For information on wiring, see "4-5. How to wire". The unpowered time must be minimized when the detector is relocated.



### CAUTION

- When using a relocated or stopped/stored detector again, do not forget to perform a gas calibration. For information on readjustment including a gas calibration, please contact RIKEN KEIKI.

## 8-3. Disposal of products

When the detector is disposed of, it must be treated properly as an industrial waste in accordance with the local regulations.

## 9

# Troubleshooting

The Troubleshooting does not explain the causes of all the malfunctions which occur on the detector. This simply helps to find the causes of malfunctions which frequently occur. If the detector shows a symptom which is not explained in this manual, or still has malfunctions even though remedial actions are taken, please contact RIKEN KEIKI.

## <Abnormalities on Unit>

Symptom/Display	FAULT	Causes	Actions
<u>The power cannot be turned on.</u>	—	The wiring is not correct.	Connect the wiring properly.
		The terminal plate is removed.	Connect the terminal plate properly.
		Abnormalities/momentary blackout of power supply system	Provide the rated voltage. Take measures such as checking or adding the UPS, power supply line filter and insulation transformer.
		Cable abnormalities (open circuit/not connected/short circuit)	Check the wiring of detector and related devices around it.
<u>Abnormal operations</u>	—	Disturbances by sudden surge noise, etc.	Turn off and restart the detector. If such a symptom is observed frequently, take appropriate measures to eliminate the noise.
<u>Sensor abnormalities</u> E-1	●	The sensor is not connected or improperly connected.	Check if the cable is securely fastened to the terminal plate.
		Faults of the sensor	Replace the sensor with a new one.
<u>System abnormalities</u> E-9	●	The rated voltage is not supplied to the detector.	Check the power supply, and supply the rated voltage.
		Abnormalities of ROM, RAM, or EEPROM inside of the detector	Please contact RIKEN KEIKI.

## &lt;Abnormalities of Readings&gt;

Symptoms	Causes	Actions
<u>The reading rises (drops) and it remains so.</u>	Drifting of sensor output	Perform the zero adjustment and the span adjustment.
	Presence of interference gas	Disturbances by interference gases, such as solvents, cannot be eliminated completely.
	Slow leak	A very small amount of the gas to be detected may be leaking (slow leak). Because ignoring it may cause dangers, take a remedial measure, i.e., taking actions the same as those for the gas alarm.
	Environmental changes	Perform the zero adjustment and the span adjustment.
<u>A gas alarm is triggered despite of no gas leak and no other abnormalities at the detection point.</u>	Presence of interference gas	Disturbances by interference gases, such as solvents, cannot be eliminated completely.
	Disturbance by noise	Turn off and restart the detector. If such a symptom is observed frequently, take appropriate measures to eliminate the noise.
	Sudden change in the environment	When the environment (temperature, etc.) changes suddenly, the detector cannot adjust to it and is affected by it. In some cases, the detector triggers an indication alarm. Because the detector cannot be used under sudden and frequent environmental changes, any preventive actions to eliminate them should be taken by the user.
<u>Slow response</u>	Deteriorated sensor sensitivity	Replace the sensor with a new one.
<u>Span adjustment impossible</u>	Improper calibration gas concentration	Use the proper calibration gas.
	Deteriorated sensor sensitivity	Replace the sensor with a new one.

## 10

# Product Specifications

## 10-1. List of specifications

### <ATEX/IECEX Specification>

Detection principle	Semiconductor
Gas to be detected	Combustible/toxic gas
Concentration display	Seven-segment LED (four-digit)
Detection range	Depends on the gas to be detected
Display resolution	Depends on the gas to be detected
Detection method	Diffusion type
Alarm setpoint	Depends on the gas to be detected
Power display	POWER lamp on (green)
Alarm accuracy (under the same conditions)	Within $\pm 25\%$ of the alarm setpoint value (combustible gas)/Within 30% of the alarm setpoint value (toxic gas)
Response time (under the same conditions)	Within 30 or 60 seconds after providing the gas 1.6 times the alarm setpoint (depending on the gas to be detected)
Gas alarm type	One-step alarm (H)
Gas alarm display	ALM lamp on (red)
Gas alarm pattern	Auto-reset
Fault alarm/self diagnosis	System abnormalities/sensor abnormalities
Fault alarm display	FAULT lamp on (yellow)/detail display
Fault alarm pattern	Auto-reset
Transmission system	Three-wire analog transmission(in common with power supply<power supply,signal,common>) or Two-wire analog transmission
Transmission specifications	4 - 20 mA DC (linear/load resistance under 250~300 $\Omega$ , resolution divided into 200)
Communication scheme	HART 7
Transmission cable (Recommended)	CVVS worth of shield cable(1.25sq)·4-core or 3-core CVVS worth of shield cable(2.0sq)·4-core or 3-core
Transmission distance	Below 1.25 km
Functions	Alarm delay/suppression
Power supply	24 VDC (17 – 26.4 VDC)
Power Consumption	Maximum 3.1 W
Cable connecting port	Pressure proof packing gland<G3/4> (Compatible cables $\phi 9.6\sim 10.5$ mm in outer diameter and rubber seals $\phi 11$ mm in inner diameter<mounted>) (Compatible cables $\phi 11.5\sim 12.5$ mm in outer diameter and rubber seals $\phi 13$ mm in inner diameter<accessory>) or Adapter A<NPT1/2> , Adapter B<NPT3/4>
Initial clear	Approx. 25 seconds
Operating temperatures	-20 - +60°C (at a constant condition)
Operating humidities	Below 95% RH (Non-condensing)
Structure	Wall mounting type
Explosion-proof structure	Flame-proof enclosures
Explosion-proof class	II 2G Ex db II C T5 Gb (ATEX) / Ex db II C T5 Gb (IECEX)

External dimensions	Approx. 148 (W) x 161 (H) x 88 (D) mm (projection portions excluded) (attached cable grand<G3/4>)
Weight	Approx. 2.0 kg
Outer color	Munsell 7.5BG5/2

Outline Drawings

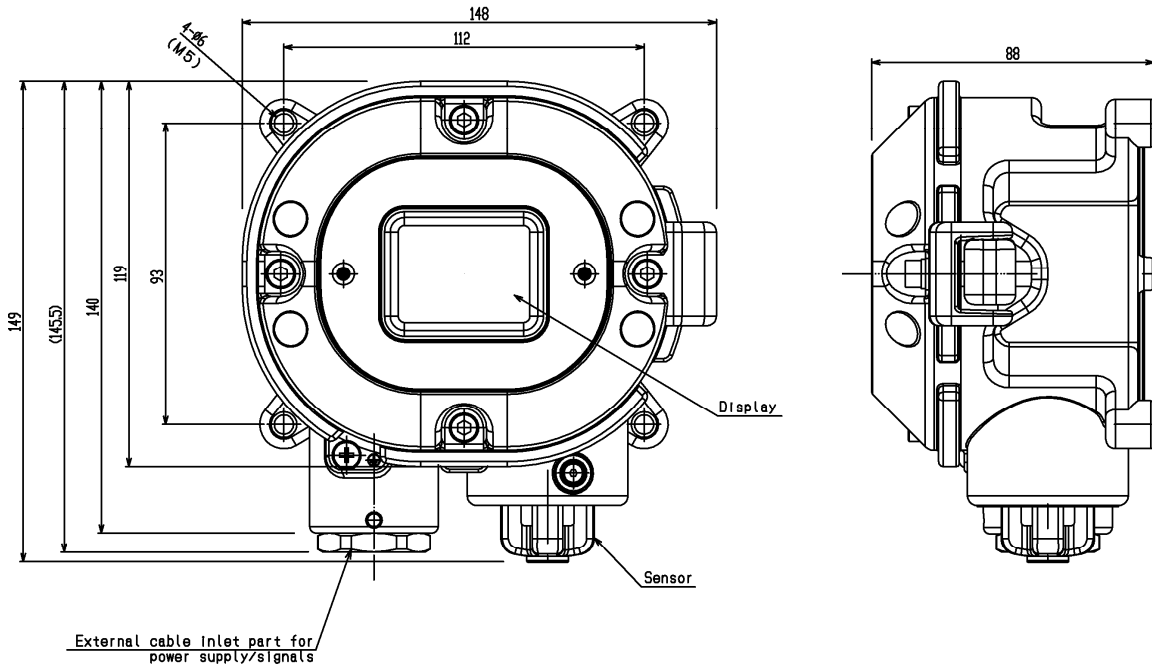

## &lt;Japan Ex Specification&gt;

Detection principle	Semiconductor
Gas to be detected	Combustible/toxic gas
Concentration display	Seven-segment LED (four-digit)
Detection range	Depends on the gas to be detected
Display resolution	Depends on the gas to be detected
Detection method	Diffusion type
Alarm setpoint	Depends on the gas to be detected
Power display	POWER lamp on (green)
Alarm accuracy (under the same conditions)	Within $\pm 25\%$ of the alarm setpoint value (combustible gas)/Within 30% of the alarm setpoint value (toxic gas)
Response time (under the same conditions)	Within 30 or 60 seconds after providing the gas 1.6 times the alarm setpoint (depending on the gas to be detected)
Gas alarm type	One-step alarm (H)
Gas alarm display	ALM lamp on (red)
Gas alarm pattern	Auto-reset
Fault alarm/self diagnosis	System abnormalities/sensor abnormalities
Fault alarm display	FAULT lamp on (yellow)/detail display
Fault alarm pattern	Auto-reset
Transmission system	Three-wire analog transmission(in common with power supply<power supply,signal,common>) or Two-wire analog transmission
Transmission specifications	4 - 20 mA DC (linear/load resistance under 250~300 $\Omega$ , resolution divided into 200)
Communication scheme	HART 7
Transmission cable (Recommended)	CVVS worth of shield cable(1.25sq)·4-core or 3-core CVVS worth of shield cable(2.0sq)·4-core or 3-core
Transmission distance	Below 1.25 km
Functions	Alarm delay/suppression
Power supply	24 VDC (17 – 26.4 VDC)
Power consumption	Maximum 3.1 W
Cable connecting port	Pressure proof packing gland
Initial clear	Approx. 25 seconds
Operating temperatures	-20 - +53°C (at a constant condition)
Operating humidities	Below 95% RH (Non-condensing)
Structure	Wall mounting type
Explosion-proof structure	Flame-proof enclosures
Explosion-proof class	Ex d II C T5 X
External dimensions	Approx. 148 (W) x 161 (H) x 88 (D) mm (projection portions excluded)
Weight	Approx. 2.0 kg
Outer color	Munsell 7.5BG5/2

\* Specifications subject to changes without notice.

Outline Drawings

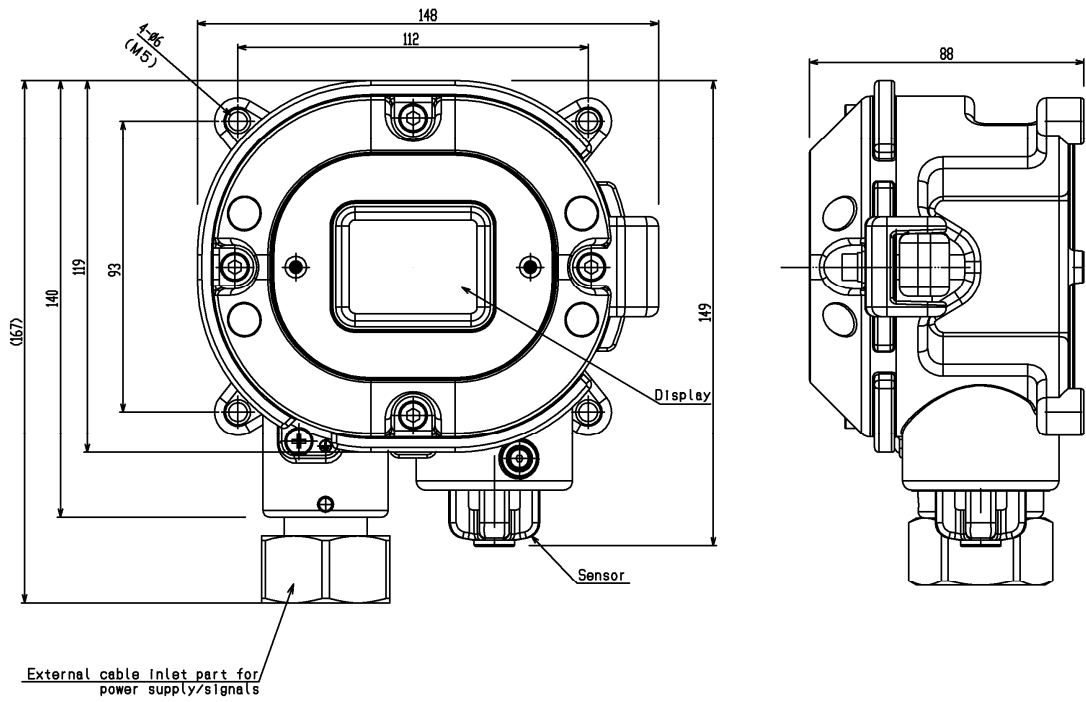

Outline Drawings

## 10-2. List of accessories

- Operating manual .....one
- Dedicated handling lever .....one
- Dedicated control key ..... The supplied quantity depends on the number of units to be delivered.

1 to 10 units	one
11 to 20 units	two
21 to 50 units	three
over 51 units	four



## 10-3. Detection principle

### <Semiconductor Type>

Metal dioxide can measure gas concentration based on changes in the electric conductivity of semiconductor caused by gas adsorbed on its surface.

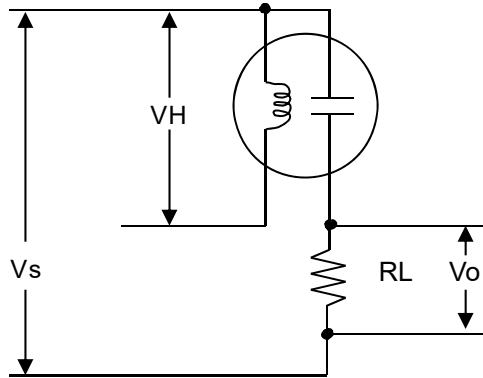

$R_L$ : Load resistance,     $V_o$ : Output voltage  
 $V_H$ : Heater voltage,     $V_s$ : Sensor voltage

---

# 11

---

## Definition of Terms

Semiconductor	This is a principle of the sensor installed in the detector. See "10-3. Detection principle" for details.
Initial clear	Output from the detector head fluctuates for a while after turning on the power. This is a function to prevent triggering alarm during that time.
Full scale	Maximum value of the detection range.
%LEL	A unit which the lower explosive limit (LEL) of the combustible gas to be detected is set to 100.
ppm	A concentration unit that means part per million of the combustible gas to be detected.
Calibration	Adjusts the readings to the calibration gas concentration value by using the calibration gas.
Zero suppression	A function to cut off the specific drifting that the sensor has.
Alarm delay time	A function which temporarily suspends activation to prevent a false alarm caused by noise from its outside.
INHIBIT	The gas detection function is temporarily suspended during maintenance, etc. of the detector. This is also called "point skip", which has the same function.
HART communication	DC4-20mA signal digitals signalling is superimposed, and is methods that transmit multiple signals.



# EU-Declaration of Conformity

Document No.: 320CE23024



We, RIKEN KEIKI Co., Ltd. 2-7-6, Azusawa, Itabashi-ku, Tokyo, 174-8744, Japan declare under our sole responsibility that the following product conforms to all the relevant provisions.

Product Name: Smart Transmitter/Gas Detector Head  
Model: SD-1, SD-1D, SD-1GH, SD-1DGH

Council Directives		Applicable Standards
2014/30/EU	EMC Directive	EN 50270:2015
2014/34/EU	ATEX Directive	EN IEC 60079-0:2018 EN 60079-1:2014
2011/65/EU <sup>[1]</sup>	RoHS Directive	EN IEC 63000:2018

<sup>[1]</sup>Including substances added by Commission Delegated Directive (EU) 2015/863

EU-Type examination Certificate No. KEMA 10ATEX0083 X

Notified Body for ATEX DEKRA Certification B.V. (NB 0344)  
Meander 1051, 6825 MJ Arnhem  
P.O. Box 5185, 6802 ED Arnhem  
The Netherlands

Auditing Organization for ATEX DEKRA Certification B.V. (NB 0344)  
Meander 1051, 6825 MJ Arnhem  
P.O. Box 5185, 6802 ED Arnhem  
The Netherlands

The marking of the product shall include the following:

 II 2 G Ex db IIC T5 Gb

Place: Tokyo, Japan

Date: Jan. 19, 2024

Takakura Toshiyuki  
General manager  
Quality Control Center