

## GAS DETECTOR WITH SIGNAL CONVERTER SD-1D (TYPE GP) (ATEX - IECEx) SPECIFICATION

Model	SD-1D
Type	TYPE GP
Detection principle	Catalytic combustion method
Detectable gas	Combustible gas
Gas concentration display	LED(4digits・7segments)
Measuring range	0~100%LEL
Resolution	0.5%LEL
Detection method	Suction method(pour into by external unit)
Suction flow	0.8~2L/min
Alarm preset point	25%LEL <b>【Standard】</b>
Power indication	POWER lamp lighting(green)
Output	Gas concentration signal Alarm contact(Gas alarm or Trouble alarm or Gas・Trouble common alarm)
Alarm accuracy (under an identical condition)	Within $\pm 25\%$ to the alarm setpoint value
Alarm-delay time (under an identical condition)	Within 30sec(when introducing 1.6 times thicker gas than alarm setpoint value) (without piping delay time)
Gas alarm type	Single alarm(H)
Gas alarm indication	ALM lamp lighting(red)
Gas alarm action	Auto-recover
Trouble alarm・Self diagnosis	System failure/Sensor failure
Trouble alarm indication	FAULT lamp lighting(yellow)/content display
Trouble alarm action	Auto-recover
Alarm contact	No-voltage contact 1a・Non-exciting at normal(exciting at alarm) or exciting at normal(non-exciting at alarm)
Contact capacity	AC250V・0.5A/DC30V・0.5A(resistive load)
Transmission scheme	Three-wire analog transmission (in common with power supply<power supply, signal, common>)
Specification of transmission	DC4~20mA (linear・load resistance less than 300 $\Omega$ ・resolution ability 200division)
Transmission cable	Control-use shield cable(AWG 16)・3-core or 5-core(by using alarm contact)
Transmission distance	Less than 1.25km
Power supply	DC24V $\pm 10\%$
Power consumption	MAX. 3W
Cabling port	Flame proof packing method (Cable gland<G3/4> or Adapter A<NPT1/2> or Adapter B<NPT3/4>)
Piping port	Rc1/8(with BS half union<for Cu pipe> or SUS half union<for SUS pipe> or PP half union<for PTFE pipe> for 0.D $\phi$ 6-1t)
Initial clear	Approx. 25sec
Operating temperature	-20~60°C (non-rapidly-vary)
Operating humidity	Less than 95%RH(non-condensing)
Structure	Wall mounting type
Explosion-proof structure	Flame proof structure
Explosion-proof grade	II 2G Ex db IIC T5 Gb(ATEX) / Ex db IIC T5 Gb(IECEx)
Outer dimension	Approx. 148(W) × 177(H) × 88(D)mm(projection excluding)
Weight	Approx. 2.2kg
Color	Munsell 7.5BG5/2

**Outline Drawings**

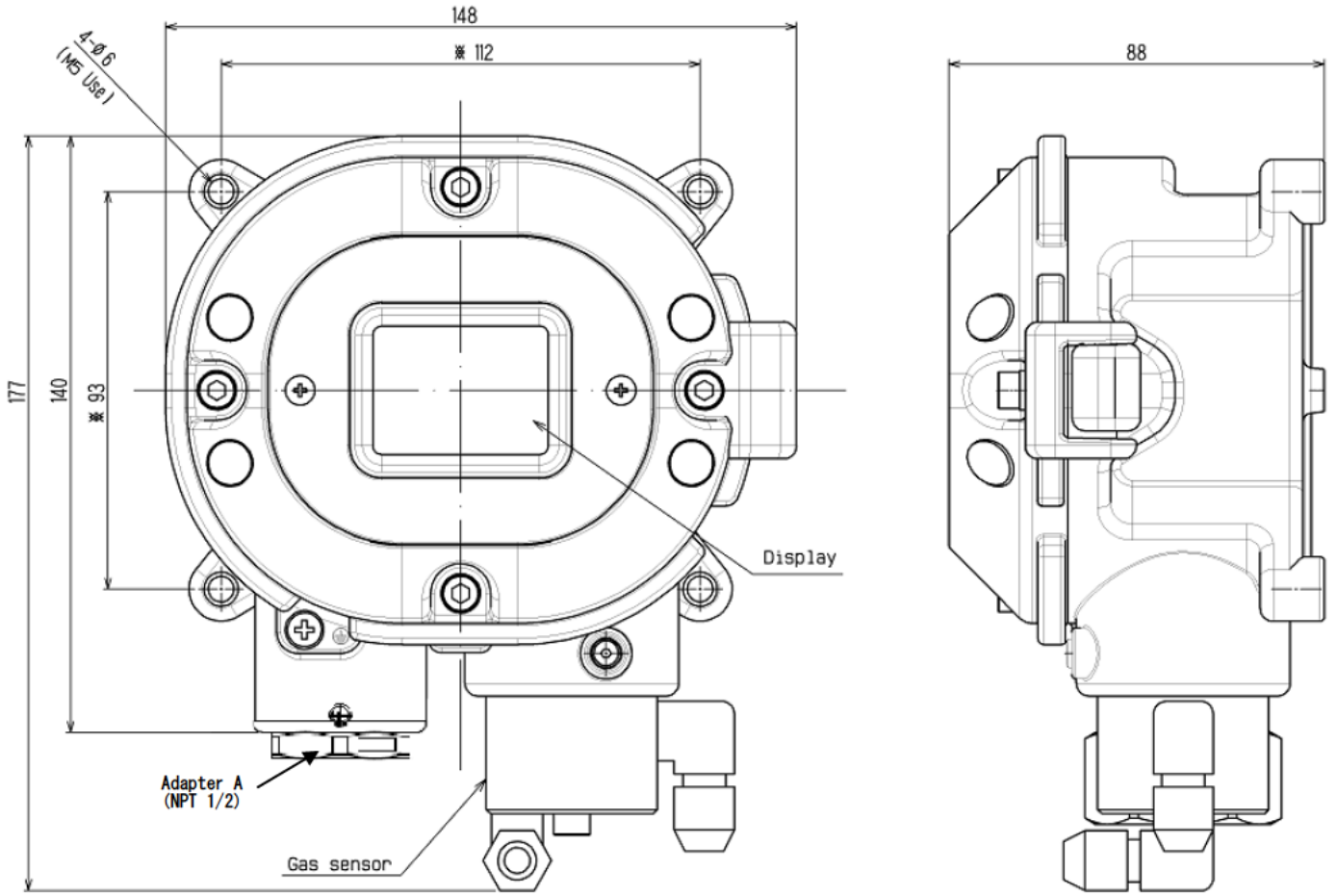

**Terminal Drawings**

DC24V	DC+	1
	-(common)	2
4-20mA	Sig+	3
	Alarm contact	4
	Alarm contact	5

**GAS DETECTOR WITH SIGNAL CONVERTER**  
**SD-1D (TYPE NC) (ATEX - IECEx) SPECIFICATION**

Model	SD-1D
Type	TYPE NC
Detection principle	New ceramic catalytic method
Detectable gas	Combustible gas
Gas concentration display	LED(4digits・7segments)
Measuring range	Depend on Detectable gas
Detection method	Suction method(pour into by external unit)
Suction flow	0.8~2L/min
Alarm preset point	Depend on Detectable gas
Power indication	POWER lamp lighting(green)
Output	Gas concentration signal Alarm contact(Gas alarm or Trouble alarm or Gas・Trouble common alarm)
Alarm accuracy (under an identical condition)	Within $\pm 25\%$ to the alarm setpoint value
Alarm-delay time (under an identical condition)	Within 30sec(when introducing 1.6 times thicker gas than alarm setpoint value) (without piping delay time)
Gas alarm type	Single alarm(H)
Gas alarm indication	ALM lamp lighting(red)
Gas alarm action	Auto-recover
Trouble alarm・Self diagnosis	System failure/Sensor failure
Trouble alarm indication	FAULT lamp lighting(yellow)/content display
Trouble alarm action	Auto-recover
Alarm contact	No-voltage contact 1a・Non-exciting at normal(exciting at alarm) or exciting at normal(non-exciting at alarm)
Contact capacity	AC250V・0.5A/DC30V・0.5A(resistive load)
Transmission scheme	Three-wire analog transmission (in common with power supply<power supply, signal, common>)
Specification of transmission	DC4~20mA (linear・load resistance less than 300 $\Omega$ )
Transmission cable	Control-use shield cable(AWG 16)・3-core or 5-core(by using alarm contact)
Transmission distance	Less than 1.25km
Power supply	DC24V $\pm 10\%$
Power consumption	MAX. 3W
Cabling port	Flame proof packing method (Cable gland<G3/4> or Adapter A<NPT1/2> or Adapter B<NPT3/4>)
Piping port	Rc1/8(with BS half union<for Cu pipe> or SUS half union<for SUS pipe> or PP half union<for PTFE pipe> for 0.D $\phi$ 6-1t)
Initial clear	Approx. 25sec
Operating temperature	-20~60°C(non-rapidly-vary)
Operating humidity	Less than 95%RH(non-condensing)
Structure	Wall mounting type
Explosion-proof structure	Flame proof structure
Explosion-proof grade	II 2G Ex db II C T5 Gb(ATEX) / Ex db II C T5 Gb(IECEx)
Outer dimension	Approx. 148(W)×177(H)×88(D)mm(projection excluding)
Weight	Approx. 2.2kg
Color	Munsell 7.5BG5/2

**Outline Drawings**

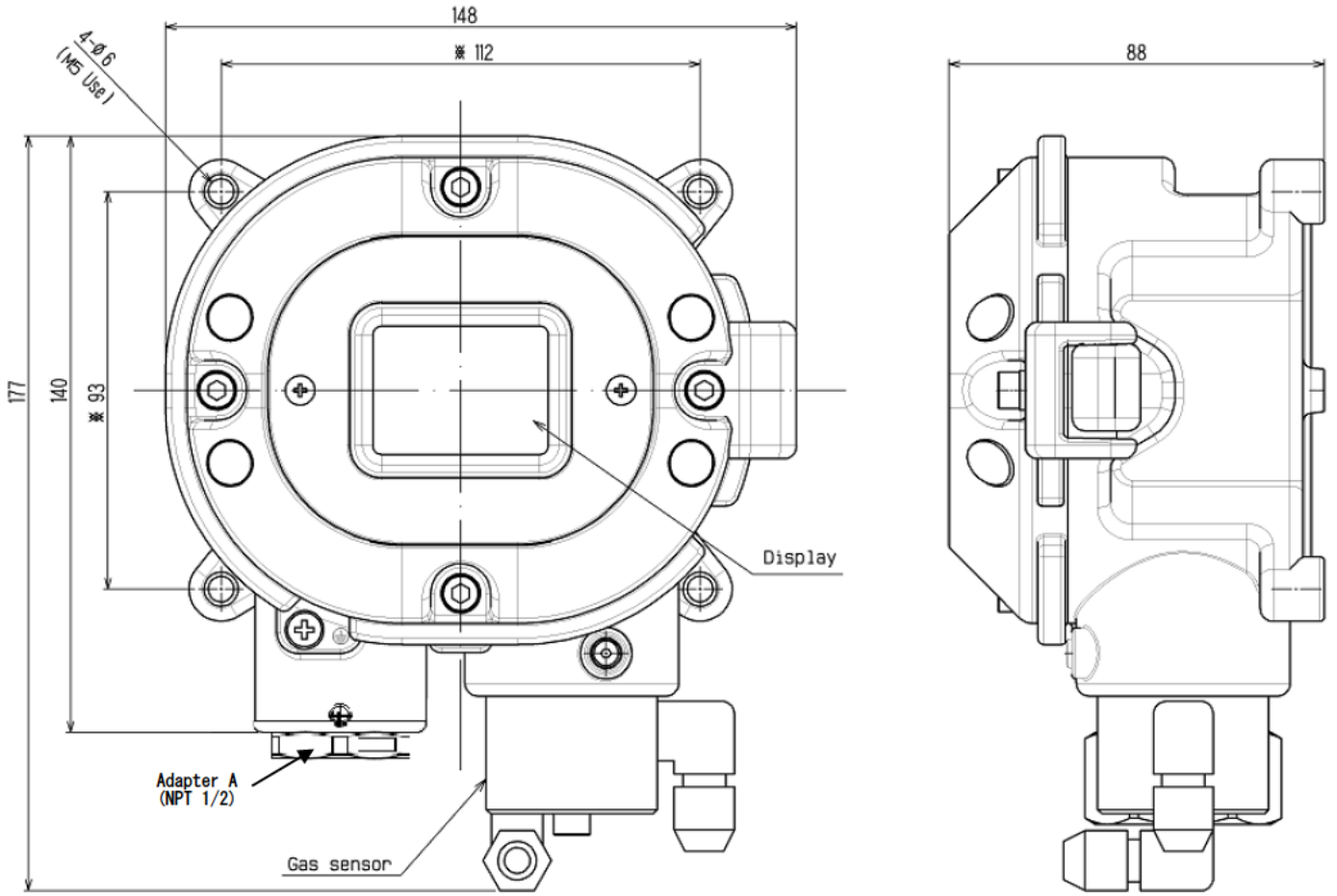

**Terminal Drawings**

DC24V	DC+	1
	-(common)	2
4-20mA	Sig+	3
	Alarm contact	4
	Alarm contact	5