



PT2E-2481

Oxygen Gas Detector Head
GD-F3A-A
Operating Manual
(PT2-149)

RIKEN KEIKI Co., Ltd.

2-7-6 Azusawa, Itabashi-ku, Tokyo, 174-8744, Japan

Phone : +81-3-3966-1113

Fax : +81-3-3558-9110

E-mail : intdept@rikenkeiki.co.jp

Web site : <https://www.rikenkeiki.co.jp/>

Operating Precautions

This detector is an oxygen deficiency detector that detects oxygen in the air and triggers an oxygen deficiency alarm.

The oxygen deficiency detector is a safety unit, not an analyzer or densitometer which performs quantitative/qualitative analysis/measurement for oxygen.

Please fully understand the following points before using it, so that it can be used properly.

1. The readings of the detector fluctuate slightly in response to changes in the air pressure. In particular, be careful of alarm activation when a low air pressure is brought in by typhoon. In addition, it may be fluctuated by environmental (temperature, humidity etc.) changes in the installation site.
2. The alarm must be set within a range where the performance of the detector can be ensured. The standard alarm setpoint value is 18 vol%.
3. This is a safety unit, not a control unit. The alarm contact output of the detector must be used for an external alarm lamp/buzzer, while the analog signal output must be used for an indicator or external recorder.
4. For maintenance of the detector, it must go through a regular maintenance, including replacement and adjustment of the regular replacement parts as specified in the operating manual. In addition, because this is a safety unit, it is recommended that a regular maintenance and span adjustment are performed every six months.

TABLE OF CONTENTS

1. PRODUCT OUTLINE	
1-1. Preface	2
1-2. Application for use	2
1-3. Definition of DANGER, WARNING, CAUTION and NOTE	2
1-4. Method of confirmation for CE/UKCA marking type (Non-explosion proof specification only)	2
2. IMPORTANT INSTRUCTIONS FOR THE SAFETY	
2-1. Danger cases	3
2-2. Warning cases	3
2-3. Caution cases	3
2-4. Cautions for the explosion proof (In case of intrinsically safe design).....	3
3. PRODUCT FUNCTION	
3-1. External dimensions	4
3-2. Names and functions for each part	5
3-3. System composition	6
4. HOW TO USE	
4-1. Before operation.....	8
4-2. Installation place	8
4-3. Maintenance space	8
4-4. Installation works	8
4-5. Caution at wiring construction	9
4-6. Applicable cable	9
4-7. Example of cable connection	9
5. OPERATION METHOD	
5-1. Preparation before start up	11
5-2. Start up.....	11
5-3. Stopping the operation	11
6. MAINTENANCE AND INSPECTION	
6-1. Inspection frequency and items	12
6-2. How to calibration	
6-2-1. Required kit and tools for calibration.....	13
6-2-2. Performing a zero adjustment	13
6-2-3. Performing a span adjustment.....	13
6-3. Replacing the sensor	
6-3-1. Replacement frequency of the sensor.....	14
6-3-2. Replacing the sensor	14
6-4. List of recommendable spare parts for regular replacement	14
7. STORAGE, RELOCATION, AND DISPOSAL	
7-1. Procedures to store the detector head or leave it for a long time	15
7-2. Procedures to relocate the detector head or use it again.....	15
7-3. Disposal of products	15
8. MEASURES AT ABNORMAL CASE	
8-1. Responding to trouble alarm	16
8-2. Before it is thought to be a trouble	16
9. PRODUCT SPECIFICATIONS	
9-1. Standard specifications	17
9-2. Standard accessories	17
9-3. Optional accessories	17
9-4. Detection principle	18
10. DEFINITION OF TERMS	19

1. PRODUCT OUTLINE

1 — 1. Preface

Thank you for choosing our fixed type Oxygen Detector Head GD-F3A-A. Please check that the model number of the product you purchased is included in the specifications on this manual.

This manual explains how to use the detector and its specifications. It contains information required for using the gas detector properly. Not only the first-time users but also the users who have already used the product must read and understand the operating manual to enhance the knowledge and experience before using the detector.

1 — 2. Application for use

This is a diffusion type oxygen detector head applying the galvanic cell type oxygen sensor and is used in combination with indicator / alarm unit to show oxygen content. Read the instruction manual for indicator / alarm unit as well as this manual.

This unit is designed as drip-proof construction for outdoor installation.

Also, it can be used as intrinsically safe system in combination with zener barrier (option) to be able to install in hazardous area.

1 — 3. Definition of DANGER, WARNING, CAUTION and NOTE

This manual contains the following headings to ensure the safe and effective operation.



This message indicates that improper handling may cause serious damage on life, health or assets.



This message indicates that improper handling may cause serious damage on health or assets.



This message indicates that improper handling may cause minor damage on health or assets.



This message indicates advice on handling.

1 — 4. Method of confirmation for CE/UKCA marking type

(Non-explosion proof specification only)

The CE/UKCA marking is labeled on the detector in case of comply with CE/UKCA mark (Non-explosion proof specification only). Please confirm the instrument specification before using. Please refer Declaration of Conformity that is at the end of this manual if you have CE/UKCA marking type.

You can confirm instrument specification to see the CE/UKCA mark as follows.

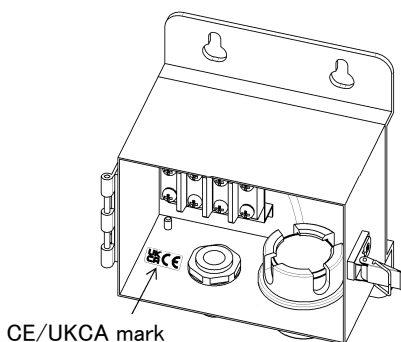

CE/UKCA mark label
(Non-explosion proof specification only)

2. IMPORTANT INSTRUCTIONS FOR THE SAFETY

2-1. Danger cases



In case of non-explosion proof system, do not use this unit at the place where combustible gas may exist.

2-2. Warning cases



- Do not cut the wire for protective ground both inside and outside of instrument. Or, do not disconnect the connection of the ground terminals.
- Before starting the operation, check if any defect is not found on the protective grounding.
If there is any defect on the protective functions such as protective grounding, do not start the operation.
- It is very dangerous if the instrument gives oxygen deficiency alarm.
Take appropriate measures based on your judgment at that time.
- Perform gas calibration at proper interval.
- Do not change or remodel the circuit/structure of this unit.
- Do not disassemble the sensor since there is an electrolyte inside.
If your finger touches the electrolyte, wash your finger way with water immediately.

2-3. Precaution



- Do not use a walky-talky around the instrument.
The indication might be affected by the electromagnetic wave generated by the walky-talky if it is used near the instrument. When the walky-talky is used, be away enough from the instrument not to affect.
- Do not control other equipment by using outputs of this detector.
This is not a control equipment. It is prohibited to control other equipment by using outputs of this detector.

2-4. Caution for explosion proof (In case of intrinsically safe design)



- Do not use this detector head expect for the measurement of oxygen content in a mixture of air and combustible gas or vapors, or a mixture of air and toxic gases.
- When cleaning this unit, do not use dry cloth but use the wet cloth not to change the static electricity on plastic part.

3. PRODUCT FUNCTION

3-1. External dimensions

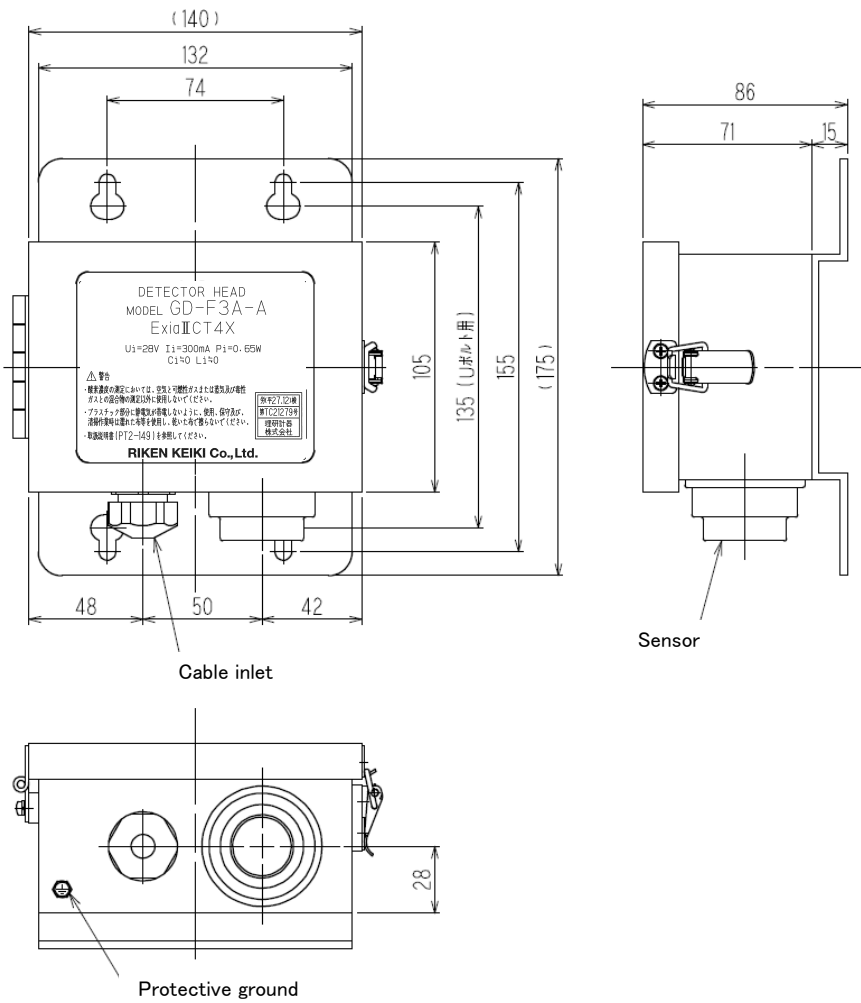

3 — 2. Names and functions for each part

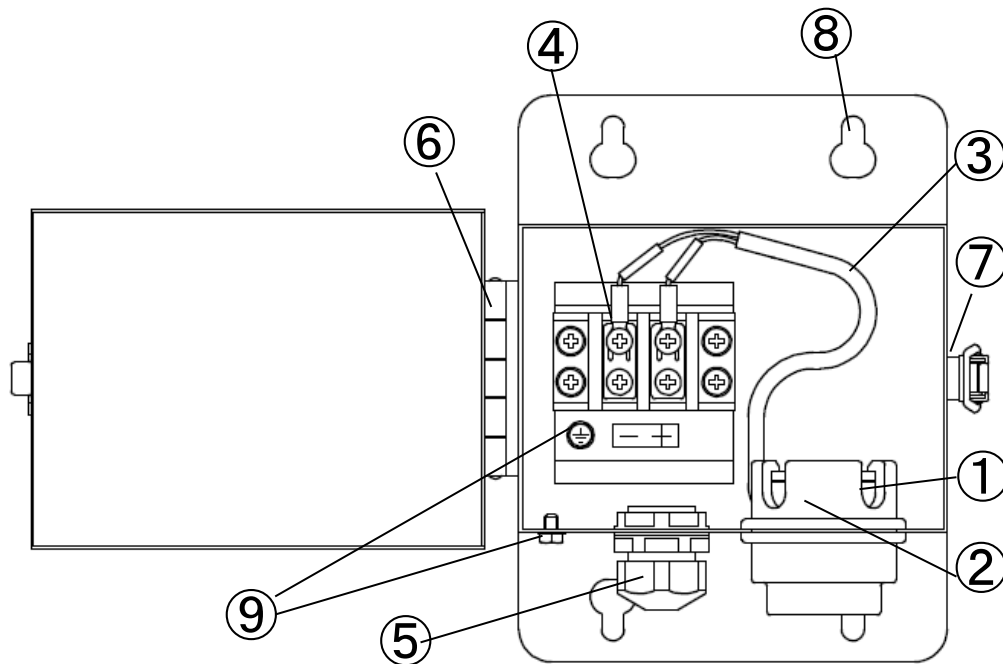

- | | |
|-------------------------|--|
| ① Oxygen sensor | : Galvanic type sensor to detect oxygen content. |
| ② Sensor holder | : This is a retainer to hold the oxygen sensor (equipped filter inside). |
| ③ Sensor lead | : Lead wires for oxygen signal outputs. |
| ④ Terminal strip | : Relayed terminal for sensor lead and external cable. |
| ⑤ Cable gland | : Entrance to lead the cable ($\phi 8 \sim \phi 11$ mm) from outside. |
| ⑥ Hinge | : Hinge for front door. |
| ⑦ Lock | : Lock for front door. |
| ⑧ Mounting hole | : Mounting hole to fix this unit on the wall surface. |
| ⑨ Protective earth bolt | : Bolt for protective grounding. |

3 — 3. System composition

(1) Intrinsically safe system

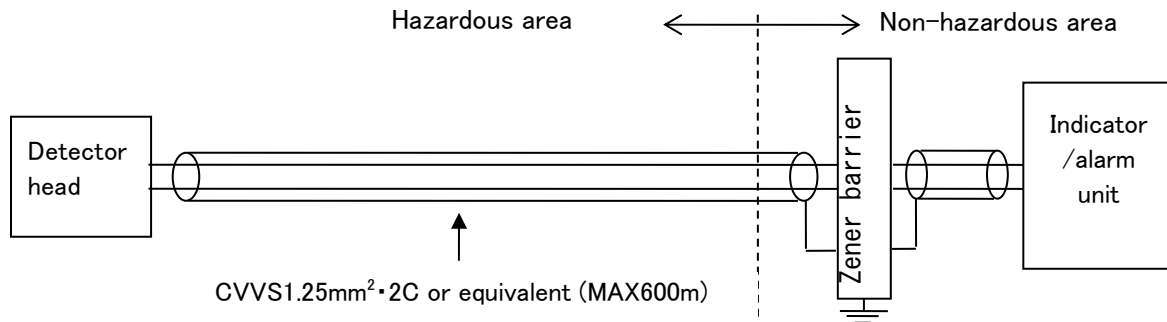

WARNING

1. The oxygen detector shall be used as following composition.

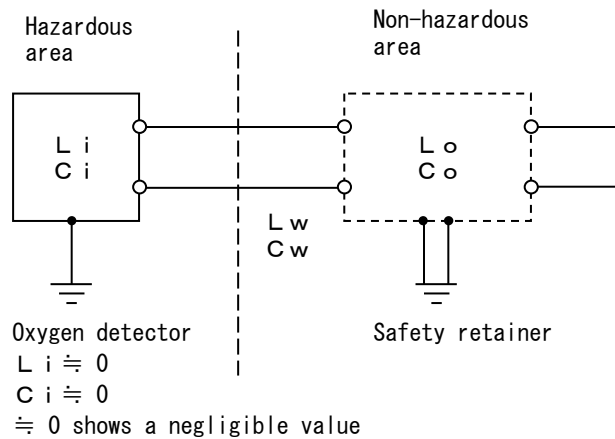

2. The safety retainer to be connected with oxygen detector shall have linear characteristics and be passed the type approval as it is.

Also it shall satisfy the following conditions.

(1) Rating of safety retainer

Max voltage of intrinsic-safety circuit: Below 28V

Max current of intrinsic-safety circuit: Below 600 mA

Max power of intrinsic-safety circuit: Below 0.75W

(2) Performance division and group

Performance division: ia

Group : II C

(3) Relations between allowable inductance (L_o) and allowable capacitance (C_o)

of intrinsic-safety circuit, and external wiring inductance (L_w) and capacitance(C_w) of intrinsic-safety circuit.

$$L_o \geq L_i + L_w$$

$$C_o \geq C_i + C_w$$

(4) When making wiring connection for intrinsic-safety circuit, take care not to induce an electric current and voltage which will spoil the performance of intrinsically safe by the electromagnetic induction or electrostatic induction to the intrinsic-safety circuit.

(2) Non-explosion proof system

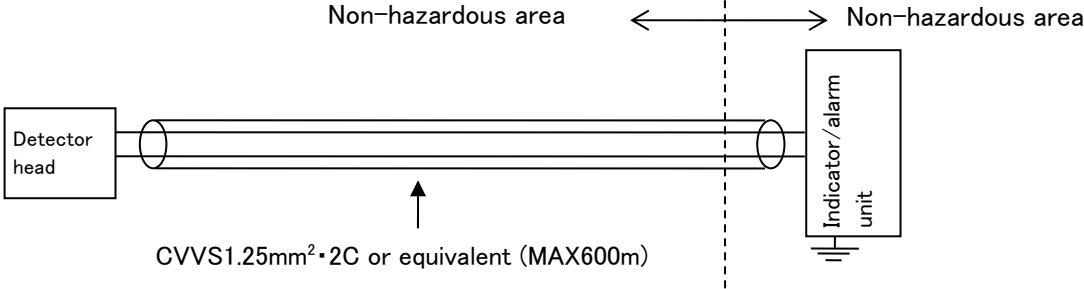

(3) Component inside detector head

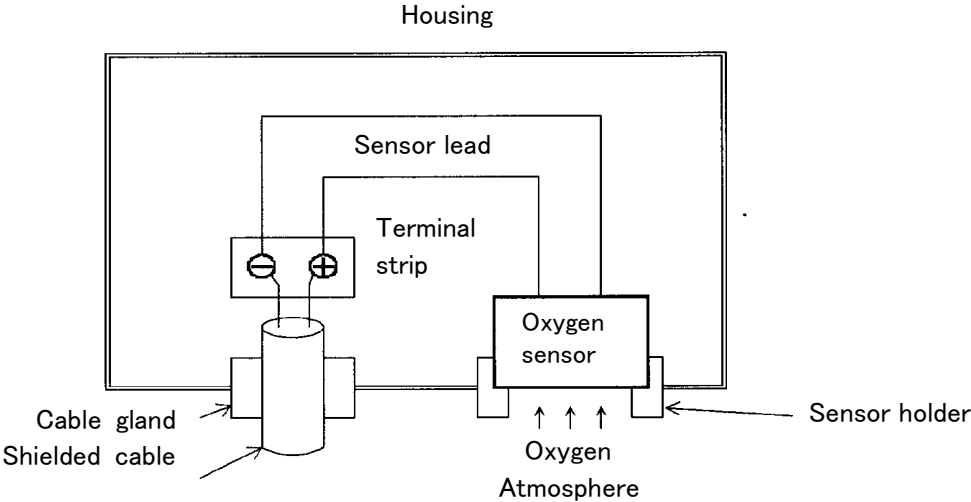

4. HOW TO USE

4 — 1. Before operation

All persons who use this detector for the first time and who has even used the detector are requested to follow all the instructions for use carefully. If not, the instrument may be defective and correct gas detection may not be performed.

4 — 2. Installation place

This detector head is installed at the place of oxygen detection directly since this is a diffusion detector head.

Note the following points.



WARNING

Do not install the detector head and cable at the following points.

- Place to get direct rays of the sun.
- Places closed to high temperature and/or emission of electromagnetic wave.
- Place with vibration or shocks.
- Place where the mounting part is weak and it is easy to come out.
- Place where it is difficult to make maintenance and inspection.
- Place unable to secure grounding.
- Places where the temperature is drastically changed.
- Places exceeding operating temperature and humidity.

4 — 3. Maintenance space

A certain maintenance space must be secured around the detector head, so that the maintenance staff can perform the safe and correct maintenance work. Pay due attention to secure this space during work plan and execution.

4 — 4. Installation work

(1) Mounting to the wall surface

Mount the detector head to a flat surface (wall surface, etc) with either M6 bolts or M10 bolts through mounting holes. Refer to "3-1. External dimensions" for mounting pitch.

(2) Mounting to the pole

The unit can be mounted to the pole (2B pipe) by using the optional U-bolts as show right figure.

(3) Installation to the outdoors

For outdoor installation, optional drip-proof cover is required to keep reliable detection although this is a drip-proof design. Contact authorized distributors, dealers or representative appointed by RIKEN KEIKI Co., Ltd.

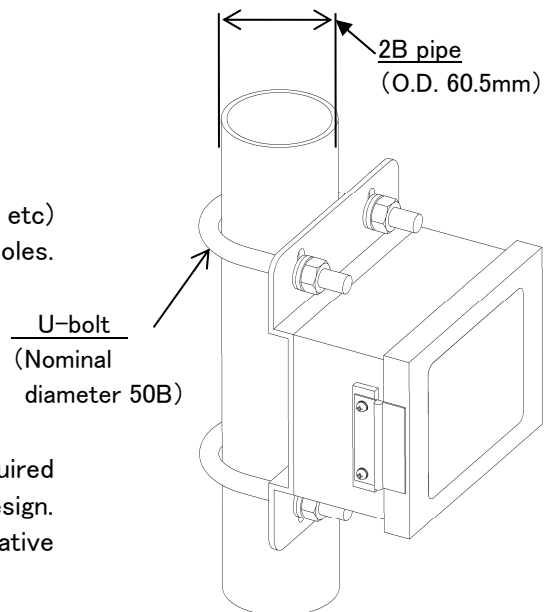

Mounting to the pole

4—5. Caution at wiring construction

CAUTION

- When make wiring construction, take care not to damage the internal electronics circuit.
- When handle the detector unit, put it at horizontal position. If put it vertically, it tends to fall and damage the detector.
- Power cable and signal cable shall not be laid down together with motive power cable such as motor, etc.
- When use twisted cable, take care not to contact a part of core cable with other core cable.

4—6. Applicable cable

Signal transmission : CVVS 1.25mm², 2C or equivalent
 Transmission distance : Within 600m at total
 Cable O.D. : $\phi 8$ - $\phi 11$ mm

4—7. Example of cable connection

(1) In case of non-explosion proof system

- ① Lead the applicable cable through cable inlet and connect to the terminal strip.
- ② Connect the other end cable to the indicator/alarm unit.
- ③ Connect the shield's drain wire at the indicator/alarm unit to the ground.

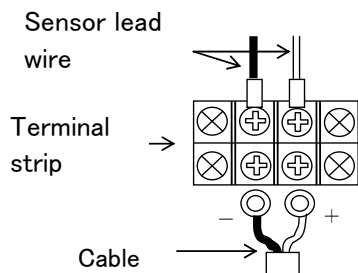

Cable connection

(2) In case of intrinsically safe system

You can build the intrinsically safe system by adding optional zener barrier between detector head and indicator/alarm unit.

- ① Lead the applicable cable through cable inlet and connect to the terminal strip.
- ② Connect the optional zener barrier between this unit and indicator/alarm unit at non-hazardous area. (See below fig.)
- ③ Connect the other end cable to the indicator/alarm unit.
- ④ Connect the shield's drain wire at the indicator/alarm unit to the chassis ground.

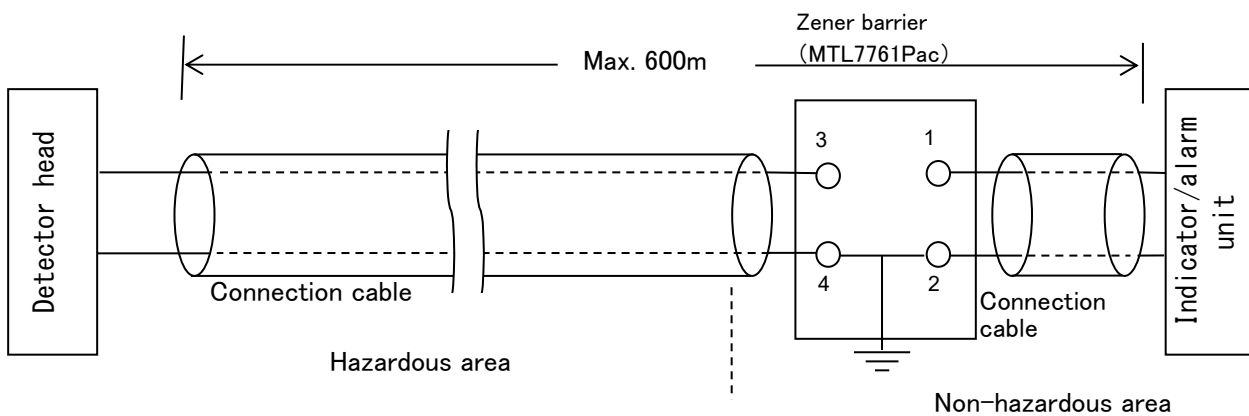

Example of intrinsically safe system



WARNING

- Ground the zener barrier separately corresponding to the A-class grounding with ground resistance of 10Ω or less.
- Use the specified cable.
- For system installation, operation and maintenance, take care not to damage the intrinsically safe design.
- The power of the indicator/alarm unit shall be turned on after completion of all wirings. If each wiring is carried out in the power on condition, short-circuit between terminals or an electrical shock may be occurred.



CAUTION

- Do not alter, nor remodel the parts, etc.
- Use the circuit breaker as for the power of indicator/alarm unit. Also it shall be mounted nearby indicator/alarm unit and be specified that it is for power interruption of indicator/alarm unit.

* NOTE

When wiring, read the operating instructions for the connected indicator/alarm unit.

5. OPERATION METHOD

5—1. Preparation before start up

Before making power on, take care of the following. If do not keep this, there is the danger of electrical shock and damage of instrument.



WARNING

- Make grounding.
- Check that the wiring with outer unit is made correctly.
- Check that the supply voltage is within the rating.

5—2. Start up

- ① This detector head does not equip a power switch. Analog outputs of oxygen sensor are transmitted to the indicator/alarm unit directory through the connected cable without signal conversion.
As far as the cable has been connected correctly, this system starts operation by putting on the power switch in indicator/alarm unit.
- ② Be sure to perform gas calibration at the time of new installation.
Correct reading may not be obtained before gas calibration.



CAUTION

- At the new installation, adjust the reading in indicator/alarm unit according to “6-2. How to Calibration”. Adjustment is done by indicator/alarm unit since the detector head has no functions for adjustment. Refer to operating instructions for the connected indicator/alarm unit.

5—3. Stopping the operation

This system stops operation by putting off the power in indicator/alarm unit, since this unit has no power switch.

6. MAINTENANCE AND INSPECTION

Gas detection and alarm instrument is kept in continuous operation over a long time and must perform a vital role as a safety device. For this purpose, periodical inspection must be made. The High-pressure Gas Safety Act in Japan sets forth the obligation of periodical inspection of the gas detection and alarm instrument.

– Maintenance Contract –

Be sure to perform the regular maintenance inspection since this is an instrument for security and safety. If this detector head founds defective, contact our nearest agent or RIKEN KEIKI soon.

6 – 1 . Inspection frequency and items

The inspection includes a daily inspection which a person in charge of control and operation of the gas detection instrument performs inspection before work once a day, and a monthly inspection carried out once a month, and periodical inspections conducted by the service personnel designated by manufacturer. The inspection items are confirmation of lights, concentration indication and alarm function on the indicator/alarm unit side. It is also necessary to carry out gas calibration at least every 6 months. The law in Japan sets forth that the unit must issue an alarm during the circuit inspection related to alarm while providing normal operation, at least, once a month.

To maintain the safety operation of the gas detection instrument, it is recommended to keep the maintenance contract with our authorized distributor for regular maintenance, adjustment and overhaul etc including the gas sensitivity adjustment (gas calibration).

For the detail of maintenance contract, contact our nearest agent or RIKEN KEIKI.



WARNING

- This is a safety instrument and the inspection every 6 months or more is mandatory to ensure the safety. If the unit is used by continuously without inspection, the sensor sensitivity may change, resulting in failure of correct detection.

* NOTE

- Be sure to inform sections concerned beforehand when performing alarm test or gas calibration. For the equipment connected with output signal from indicator/alarm unit, perform them after disconnecting the output signal.
- Special trained engineer for gas detection instrument can perform maintenance work and inspection accurately and efficiently. Then, it is recommended to contact our authorized agent for maintenance and inspection.

6—2. How to calibration

Perform gas calibration at new installation, 6 months inspection and sensor replacement.

6—2—1. Required kit and tools for calibration

Prepare following jigs and tools to perform zero and span adjustments.

- Calibration adapter
- Calibration gas (standard gas for zero and span)
- Gas sampling bag for calibration gas
- Suction pump to lead calibration gas
- Flowmeter with flow control valve (enable to control 1.0L/min).

6—2—2. Performing a zero adjustment

- ① Pack the zero gas (Nitrogen more than 99.9 vol %) into gas sampling bag.
- ② Connect calibration adapter, flowmeter (with flow control valve) and suction pump to the detector head. Turn on the pump and adjust the reading of flowmeter to 1.0 ± 0.3 L/min.
- ③ Connect gas sampling bag for calibration to the IN side of the pump.
- ④ After reading by indicator/alarm unit gets stable, adjust the reading to zero with respective potentiometer of indicator/alarm unit.
- ⑤ Stop the supply of zero gas, disconnect calibration adapter and confirm that the oxygen reading returns to 20.9vol %.

6—2—3. Performing a span adjustment

- ① Pack the span gas (fresh air for oxygen deficiency alarm instrument and their concentration is around preset alarm level for other purpose) into gas sampling bag.
For simple calibration, you may be possible to use an ambient air as span gas containing 20.9vol% O₂ providing that the ambient pressure is 1 atm (1000 ± 50 hpa) and contamination in air is negligible against span gas concentration.
- ② Connect calibration adapter, flowmeter (with flow control valve) and suction pump to the detector head. Turn on the pump and adjust the reading of flowmeter to 1.0 ± 0.3 L/min.
- ③ Connect gas sampling bag for calibration to the IN side of the pump.
- ④ After reading by indicator/alarm unit gets stable, adjust the reading to the span gas concentration with respective potentiometer of indicator/alarm unit.
- ⑤ Stop the supply of span gas, disconnect calibration adapter and confirm that the oxygen reading is 20.9vol % (completion of span calibration).

6—3. Replacing the sensor

6—3—1. Replacement frequency of the sensor

To maintain the reliability of the measurement, it is recommendable to replace the sensor periodically. Our oxygen sensor has an enough life span. However, the actual life is depending on the operating conditions. Then, replace the sensor once a year as the tentative deadline for the replacement cycle.

6—3—2. Replacing the sensor

- ① Verify that the indicator/alarm unit is off. If the sensor is disconnected, the indicator/alarm unit issues an alarm.
- ② Turn a lock of detector head and open the front door.
- ③ Loosen two screws at the top of terminal strip and disconnected two lead (black and white) wires.
- ④ Push the sensor upword from the bottom of sensor and pull out it from the holder.
- ⑤ Insert new sensor into the holder and push the sensor until it comes to the end.
- ⑥ Connect black and white sensor lead wires to the terminal strip. Connect white wire to positive (+) terminal and black wire to negative (-) terminal respectively.
- ⑦ Close the front door of the detector head and fasten a lock.

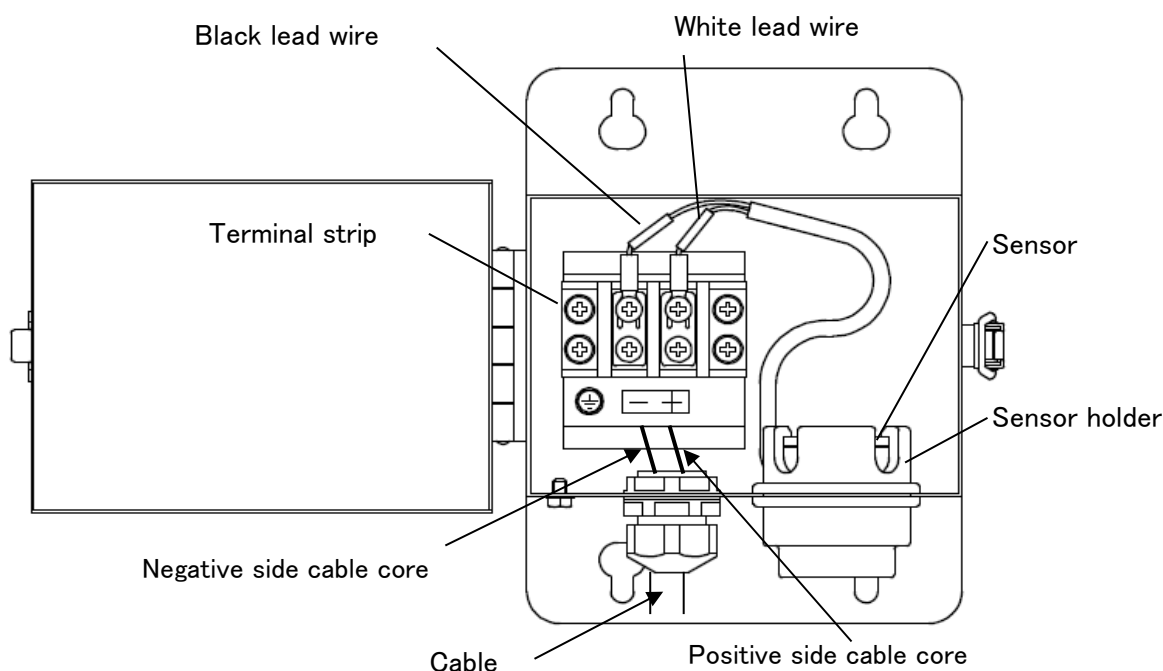

CAUTION

- Be sure to carry out gas calibration after sensor replacement. If not, correct gas detection may not be performed.

6—4. List of recommendable spare parts for regular replacement

No.	Name of parts	Inspection frequency	Replacement interval	Q'ty/unit
1	Sensor holder	At sensor replacement	At sensor replacement	1

* NOTE

The replacement interval will change depending on operating condition and it does not mean the guarantee period. Replacement interval changes according to the result of regular inspection.

7. STORAGE, RELOCATION AND DISPOSAL

7—1. Procedures to store the detector head or leave it for a long time

The detector head must be stored under the following environmental conditions.

- In a dark place under the normal temperature and humidity away from direct sunlight
- In a place where gases, solvents or vapors are not present

7—2. Procedures to relocate the detector head or use it again

When the detector head is relocated, select a new place in accordance with “4-2. Installation place” and “4-4. Installation works”.

For information on wiring work, see “4-5. Caution at wiring construction”. The unpowered time must be minimized when the detector head is relocated.



CAUTION

- When using a relocated or stopped/stored detector head again, never fail to perform a calibration. For information on readjustment including a calibration, please contact RIKEN KEIKI.

7—3. Disposal of products

When the detector head is disposed of, it must be treated properly as an industrial waste in accordance with the local regulations.

8. MEASURES AT ABNORMAL CASE

8 — 1. Responding to trouble alarm

If this detector founds defective, contact our authorized agent or RIKEN KEIKI.

8 — 2. Before it is thought to be a trouble

It may be caused by cable disconnection, short circuit, etc.

•Check the wirings around the related instruments as well as this detector head.

It may be caused by improper operation.

•Re-check the detection system and contact our authorized agent or RIKEN KEIKI.

9. PRODUCT SPECIFICATIONS

9 – 1. Standard specifications

Model	GD-F3A-A
Detection principle	Galvanic cell method
Detectable gas	O ₂
Detection method	Diffusion method
Transmission scheme	Direct output from sensor
Transmission cable	CVVS worth of shield cable(1.25mm ²)·2-core
Transmission distance	Less than 600m by CVVS·1.25mm ² cable
Zener barrier	MTL7761Pac
Cabling port	Cable gland(Suitable cable dia $\phi 8 \sim \phi 11$ mm)
Operating temperature	-10~+40°C (non-rapidly-vary. It may differ according to mounted sensor.)
Operating humidity	Less than 95%RH (non-condensing. It may differ according to mounted sensor.)
Structure	Wall mounting type/mountable to pipe size 2B<50A>
Explosion-proof structure	Intrinsically safe structure(by using zener barrier)
Explosion-proof grade	Exia II CT4X
Outer dimension	Approx.140(W) × 175(H) × 86(D)mm
Weight	Approx.1.4kg
Color	Munsell 2.5Y9/2 semi-gloss

9 – 2. Standard accessories

- Operating instruction

9 – 3. Optional accessories

- U-bolt (for nominal diameter 2B)
- Calibration adapter
- Zener barrier (MTL7761Pac)

9 — 4. Detection principle

[Detection principle]

A negative electrode of noble metal and a positive electrode of lead are placed in a resin container filled with electrolyte. A part of the container is opened and covered with a barrier. The negative electrode is installed in contact with the barrier. Lead wires are drawn from the positive and negative electrodes to obtain outputs. A thermistor is connected between the lead wires to perform temperature compensation for the sensor outputs.

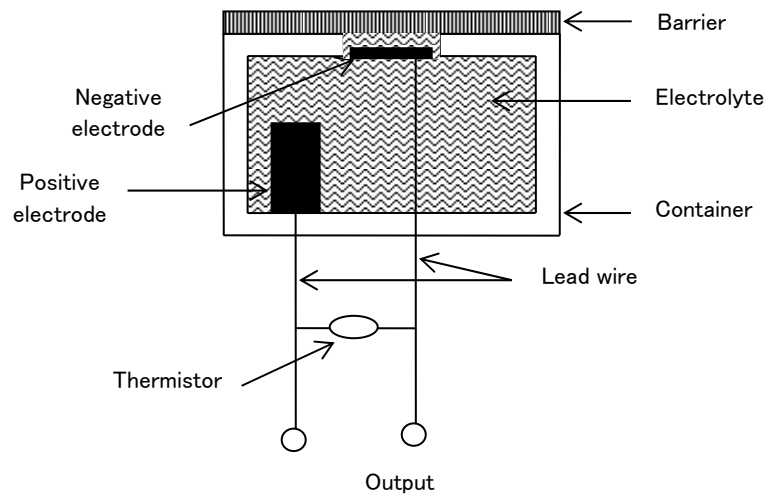

10. DEFINITION OF TERMS

Galvanic cell

Galvanic cell type oxygen sensor that produces a current proportional to the oxygen content permeated through the membrane. Refer to “9-4. DETECTION PRINCIPLE” for details.

Zener barrier

Safety retainer for explosion protection by limiting the energy of electric current within a non-ignition level.

CVVS

This is a kind of connecting cable between indicator/alarm unit and oxygen detector head. CVVS means a “Polyethylene insulated and vinyl sheathed control cable with shield”.

Calibration

By using standard (calibration) gas, adjust gas reading in indicator/alarm unit to match the calibration gas concentration.

Manual Log

Rev.	Amendment	Issue data
0	First issue	2017/2/13
1	Addition: Declaration of Conformity	2022/7/22



EU-Declaration of Conformity

Document No.: 320CE22047



We, RIKEN KEIKI Co., Ltd. 2-7-6, Azusawa, Itabashi-ku, Tokyo, 174-8744 Japan declare under our sole responsibility that the following product conforms to all the relevant provisions.

Product Name: Oxygen Gas Detector Head
Model: GD-F3A-A

Council Directives		Applicable Standards
2014/30/EU	EMC Directive	EN 50270:2015
2011/65/EU ^[1]	RoHS Directive	EN IEC 63000:2018

^[1]Including substances added by Commission Delegated Directive (EU) 2015/863

Place: Tokyo, Japan

Date: Jun. 29, 2022

Takakura Toshiyuki
General manager
Quality Control Center



UK-Declaration of Conformity

Document No.: 320UK22017



We, RIKEN KEIKI Co., Ltd. 2-7-6, Azusawa, Itabashi-ku, Tokyo, 174-8744 Japan declare under our sole responsibility that the following product conforms to all the relevant provisions.

Product Name: Oxygen Gas Detector Head
Model: GD-F3A-A

Regulations	UK designated Standards
Electromagnetic Compatibility Regulations 2016 (S.I. 2016/1091)	BS EN 50270:2015
The Restriction of the Use of Certain Hazardous Substances in Electrical and Electronic Equipment Regulations 2012 (S.I. 2012/3032)	BS EN IEC 63000:2018

Place: Tokyo, Japan

Date: May. 27, 2022

Takakura Toshiyuki
General manager
Quality Control Center