



PT2E-16214

Furnace Gas Detector Head GD-A2400

Operating Manual

(PT2E-162)

(PT2-162)

RIKEN KEIKI Co., Ltd.

2-7-6 Azusawa, Itabashi-ku, Tokyo, 174-8744, Japan

Phone : +81-3-3966-1113

Fax : +81-3-3558-9110

E-mail : intdept@rikenkeiki.co.jp

Web site : <https://www.rikenkeiki.co.jp/>

Operating Precautions

This detector head is a gas detector that detects combustible gases in the air and triggers a gas alarm. The gas detector is a safety unit, not an analyzer or densitometer which performs quantitative/qualitative analysis/measurement for gases.

Please fully understand the following points before using it, so that it can be used properly.

1. This detector head may be interfered by gases and vapors other than the gas to be detected. Please note that the alarm may be triggered by interference. In addition, it may be fluctuated by environmental (temperature, humidity, etc.) changes in the installation site.
2. The alarm must be set within a range where the performance of the detector head can be ensured. In facilities compliant with the High Pressure Gas Safety Act, an alarm setting below our standard alarm setpoint may trigger a false alarm.
3. This is a safety unit, not a control unit. The alarm contact output of the detector head must be used for an external alarm lamp/buzzer, while the analog signal output must be used for an indicator or external recorder. If these outputs are used to control other units, we shall not be responsible for any malfunctions.
4. The gas sensing part of the gas detection sensor installed in this detector head is made of metal porous sintered alloy permeated with an oxidation catalyst. If silicon or sulfide compounds are accumulated on the surface of porous sintered alloy, the area of the gas sensing part becomes smaller, which may result in serious deterioration of its sensitivity. For safety reasons, do not use the detector head under the presence of silicon or sulfide compounds even though their amount is very small.
5. For maintenance of the detector head, it must go through a regular maintenance, including replacement and adjustment of the regular replacement parts as specified in the operating manual. In addition, because this is a safety unit, it is recommended that a regular maintenance and a gas calibration are performed every six months in accordance with the regulations.

<Contents>

1	Outline of the Product.....	2
1-1.	Preface	2
1-2.	Purpose of use	2
1-3.	Definition of DANGER, WARNING, CAUTION, and NOTE	2
1-4.	Method of confirmation for Standards and Explosion proof specification.....	3
2	Important Notices on Safety	4
2-1.	Danger cases	4
2-2.	Warning cases.....	4
2-3.	Precautions	5
2-4.	Safety Information	5
3	Product Components.....	7
	Main unit and standard accessories	7
4	How to Use.....	8
4-1.	Before using the detector head	8
4-2.	Precautions for installation points.....	8
4-3.	Precautions for system designing.....	9
4-4.	How to install	10
4-5.	How to wire.....	11
5	How to Operate	16
5-1.	Preparation for start-up.....	16
5-2.	How to start the detector head	16
5-3.	How to exit.....	16
6	Maintenance.....	17
6-1.	Maintenance intervals and items	17
6-2.	Gas calibration method.....	18
6-3.	Parts replacement	19
7	Storage, Relocation and Disposal	20
7-1.	Procedures to store the detector head or leave it for a long time	20
7-2.	Procedures to relocate the detector head or use it again	20
7-3.	Disposal of products.....	20
8	Troubleshooting.....	21
9	Product Specifications	23
9-1.	List of specifications	23
9-2.	List of accessories	24
9-3.	Detection principle	24
10	Definition of Terms.....	25

1

Outline of the Product

1-1. Preface

Thank you for choosing our furnace gas detector head GD-A2400. Please check that the model number of the product you purchased is included in the specifications on this manual.

This manual explains how to use the detector head and its specifications. It contains information required for using the detector head properly. Not only the first-time users but also the users who have already used the product must read and understand the operating manual to enhance the knowledge and experience before using the detector head.

Product specifications may be abbreviated in this document as follows.



Japan Ex specification : Japan specification

ATEX / IECEx specification : Export specification

1-2. Purpose of use

- This detector head is a fixed type gas detector head which detects combustible gases in the furnace.
- This detector head is a safety unit, not a device aimed at performing quantitative/qualitative analysis/measurement for gases. Please fully understand the features of the detector head before using it, so that it can be used properly.
- The detector head detects combustible gases and outputs voltages according to gas concentrations.
- It must be used in combination with an indicator/alarm unit (optional). An indicator/alarm unit (optional) displays concentrations and triggers an alarm when the alarm setpoint is exceeded.

1-3. Definition of DANGER, WARNING, CAUTION, and NOTE

 DANGER	This message indicates that improper handling may cause serious damage on life, health or assets.
 WARNING	This message indicates that improper handling may cause serious damage on health or assets.
 CAUTION	This message indicates that improper handling may cause minor damage on health or assets.
NOTE	This message indicates advice on handling.

1-4. Method of confirmation for Standards and Explosion proof specification

This instrument has some specification depends on standard and explosion proof certificate. Please confirm the detector specification before using. Please refer Declaration of Conformity that is at the end of this manual if you have CE marking type.

You can confirm instrument specification to see name plate as follows.

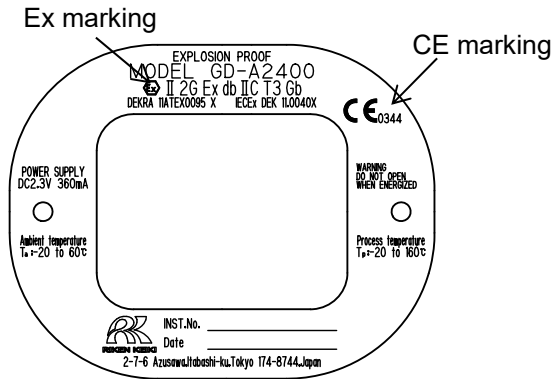

ATEX/IECEX, CE marking type name plate

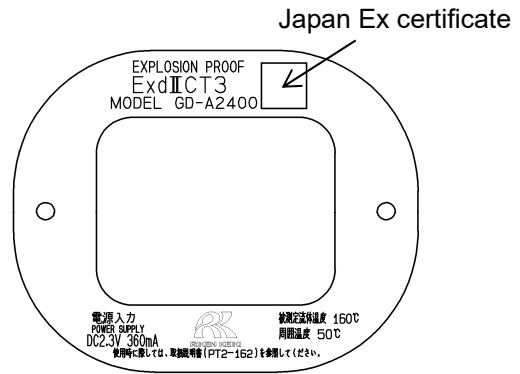

Japan Ex type name plate

2

Important Notices on Safety

2-1. Danger cases



DANGER

<About explosion-proof>

- The window plate material is a polycarbonate resin. Do not use organic solvents and alkali types (liquid or vapor).
It may cause the color and shape of the window plate to be changed.
- Do not open the lid when applying current.
- Do not attempt to repair the detector.
- For the lid, use hexagon socket head bolts specified by RIKEN KEIKI.
- Do not apply a strong force or shock to the window plate. The explosion-proof performances may be deteriorated due to damages. The explosion protection conditions for the detector is "low (2J)" possibility of mechanical damage.
- Do not repair the explosion-proof joint surface.

2-2. Warning cases



WARNING

Need of grounding circuit

Do not cut the grounding circuit or disconnect the wire from the grounding terminal.

Defects in protective functions

Before starting the detector head, check the protective functions for defects. When seeming defects are found in the protective functions, such as protective grounding, do not start the detector head.

Zero adjustment in the atmosphere

When the zero adjustment is performed in the atmosphere, check the atmosphere for freshness before beginning the adjustment. If other gases exist, the adjustment cannot be performed properly, thus leading to dangers when the gas leaks.

Response to a gas alarm

Issuance of a gas alarm indicates that there are extreme dangers. Take proper actions based on your judgment.

2-3. Precautions



CAUTION

Do not use a transceiver near the detector head.

Radio wave from a transceiver near the detector head or its cables may disturb indication reading. If a transceiver is used, it must be used in a place where it disturbs nothing.

Do not disassemble/modify the detector head.

Disassembling/Modifying the detector head will invalidate the warranty of the performance. Please use the detector head properly in accordance with the operating manual.

Avoid applying organic solvents and others to the window plate for a long time.

The window plate material is a polycarbonate resin. Do not use organic solvents and alkali types (liquid or vapor). It may cause the color and shape of the window plate to be changed.

Do not forget to perform a regular maintenance.

Since this is a safety unit, a regular maintenance must be performed to ensure safety. Continuing to use the detector head without performing a maintenance will deteriorate the sensitivity of the sensor, thus resulting in inaccurate gas detection.

2-4. Safety Information

Necessary information for explosion proof construction of Model GD-A2400.

<ATEX/IECEX Specifications>

The Model GD-A2400 is a fixed mount, detector head monitoring gas.

Technical Data

(Protection Method)	Flameproof enclosure “d”
(Certificate Numbers)	IECEX DEK 11.0040X DEKRA 11ATEX0095 X
(Group)	II
(Category)	2 G
(Type of Protection and Marking code)	Ex db IIC T3
(Equipment Protection Level)	Gb
(Ambient Temperature)	-20°C to +60°C
(Process Temperature)	-20°C to +160°C
(Electrical Data)	Supply voltage: 2.3 V dc (Typ.)
(Applicable Standard)	IEC 60079-0: 2017, IEC 60079-1: 2014 EN IEC 60079-0: 2018, EN 60079-1: 2014
(Manual Number)	PT2E-162

Installation

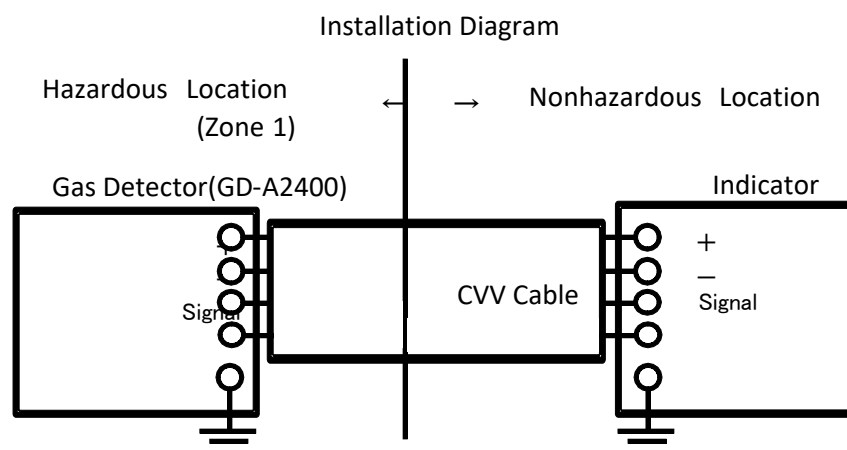

3

Product Components

Main unit and standard accessories

Main Unit (including a cable gland)

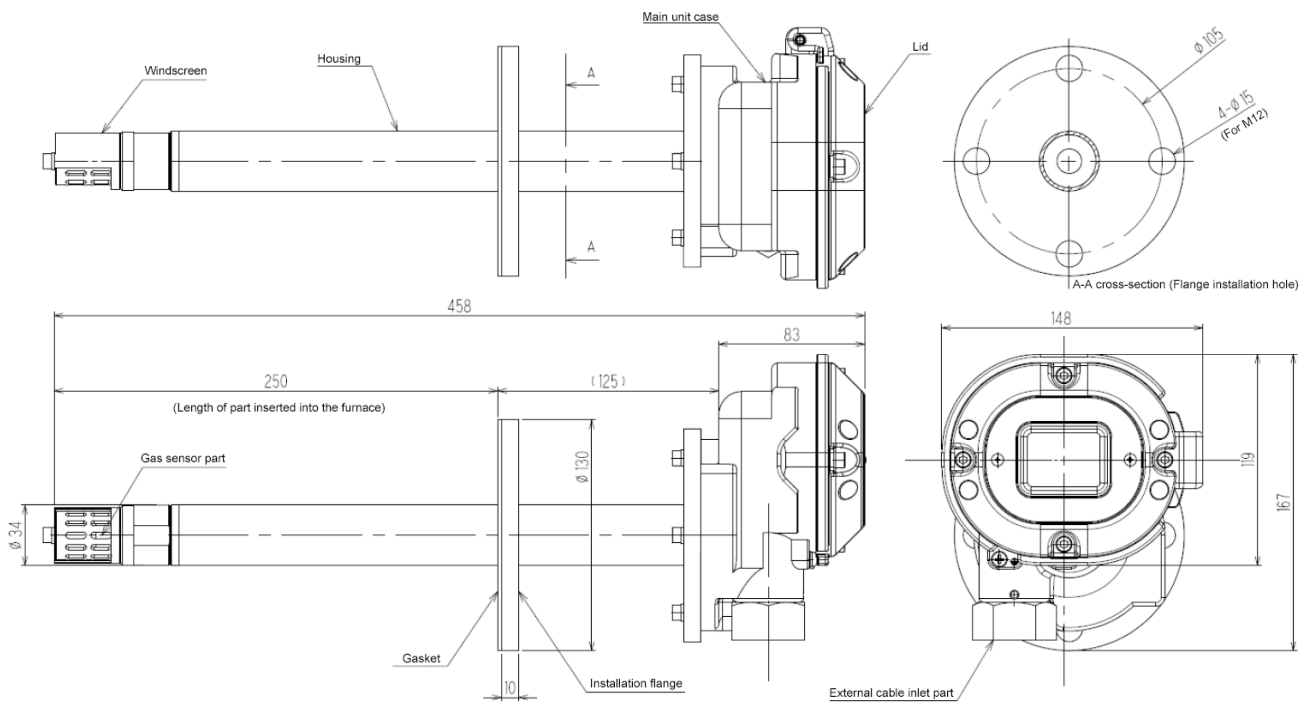

Standard Accessories

- Operating manual
- Dedicated handling lever (used for the wiring)
- Flange gasket
- Exhaust air direction nameplate

4

How to Use

4-1. Before using the detector head

Not only the first-time users but also the users who have already used the product must follow the operating precautions.

Ignoring the precautions may damage the detector head, resulting in inaccurate gas detection.

4-2. Precautions for installation points



CAUTION

This is a precision device. Because the detector head may not provide the specified performance in some places (environments), check the environment in the installation point, and then take appropriate actions if necessary.

Because the detector head plays an important role for safety and disaster prevention, as many units of the detector head as needed must be installed in appropriate points.

Because points where gases leak and remain easily are different depending on the types of gases and the working areas, please decide carefully on installation points and the number of units to be installed.

Do not install the detector head in a place with vibrations or shocks.

The detector head must be installed in a stable place without vibrations or shocks and it cannot drop.

Do not install the detector head in a place exposed to water, oil or chemicals.

When selecting installation points, avoid a place where the detector head is exposed to water, oil or chemicals.

Install the detector head in a place with operating environment temperatures that meet the following requirements:

<Export Specification>

Main unit case part:

The detector head must be installed in a stable place where the operating temperature is 0 to +50°C and do not change suddenly.

Gas sensor part: 0 to +160°C

<Japan Specification>

Main unit case part:

The detector head must be installed in a stable place where the operating temperature is -20 to +60°C and do not change suddenly.

Gas sensor part: 0 to +160°C

Do not install the detector head in a place exposed to direct sunlight or sudden changes in the temperature.
 When selecting installation points, avoid a place where it is exposed to direct sunlight or radiant heat (infrared rays emitted from a high-temperature object), and where the temperature changes suddenly. Condensation may be formed inside the detector head, or the detector head cannot adjust to sudden changes in the temperature.

Keep the detector head (and its cables) away from noise source devices.
 When selecting installation points, avoid a place where high-frequency/high-voltage devices exist.

Do not install the detector head in a place where maintenance of the detector head cannot be performed or where handling the detector head involves dangers.
 Regular maintenance of the detector head must be performed.
 Do not install the detector head in a place where the machinery must be stopped when maintenance is performed in its inside, where parts of the machinery must be removed to perform maintenance, or where the detector head cannot be removed because tubes or racks prevent access to it. Do not install the detector head in a place where maintenance involves dangers, for example, near a high-voltage cable.

Do not install the detector head in machinery which is not properly grounded.
 Before installing the detector head in machinery, the machinery must be grounded properly.

Do not install the detector head in a place where other gases exist around it.
 The detector head must not be installed in a place where other gases exist around it.

4-3. Precautions for system designing



CAUTION

An unstable power supply and noise may cause malfunctions or false alarms.
 The descriptions in this section must be reflected on the designing of a system using the detector head.

Introducing protective measures against lightning
 If cables are installed outside the factory/plant, or if internal cables are installed in the same duct as the cables coming from outside the factory/plant, "lightning" will cause problems. Because lightning acts as a large emission source while cables act as a receiving antenna, devices connected to the cables may be damaged. Lightning cannot be prevented. Cables installed in a metal conduit or under the ground cannot be completely protected from inductive lightning surge caused by lightning. Although complete elimination of disasters caused by lightning is impossible, the following protective measures can be taken.

Protection against lightning	<p><u>Take appropriate measures in accordance with the importance of the facilities and the environment.</u></p> <ul style="list-style-type: none"> • Provide protection by a lightning arrester (cable arrester). (Although inductive lightning surge can be transmitted through the cable, it is prevented by installing a lightning arrester before the field devices and central processing equipment. For information on how to use a lightning arrester, please contact the manufacturer.)
Grounding	In addition to lightning, there are more sources of surge noise. To protect units from these noise sources, the units must be grounded.

* The lightning arrester has a circuit to remove a surge voltage which damages field devices, so that signals may be attenuated. Before installing a lightning arrester, verify that it works properly.

4-4. How to install

<Maintenance Space>

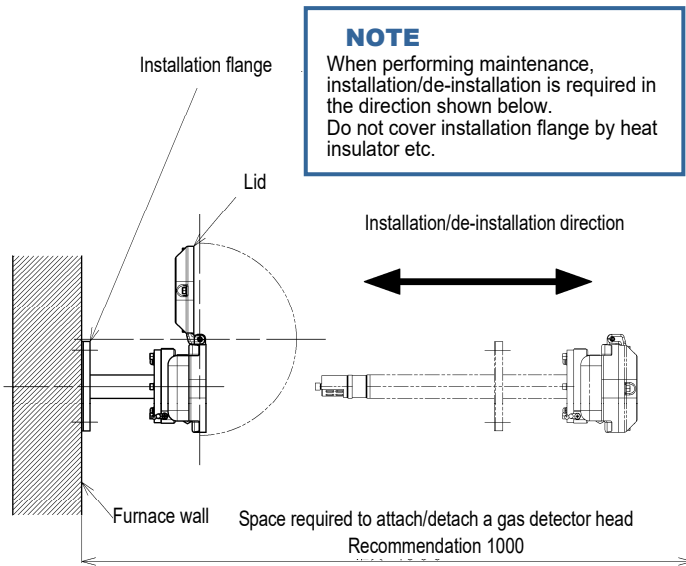

<How to fix the windscreen>

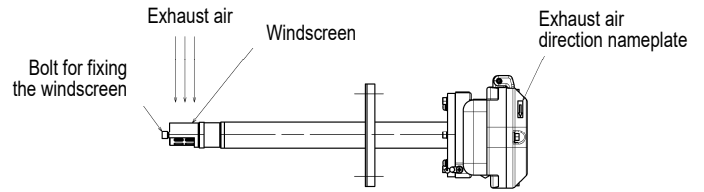

WARNING

- When the detector head is to be installed in a furnace, make sure that the exhaust air hits the windscreen where it is installed.
- Securely fix the windscreen with bolts for fixing it. After the gas detector head is installed, affix the supplied "exhaust air direction nameplate" on the surface of the lid.

<How to Install>

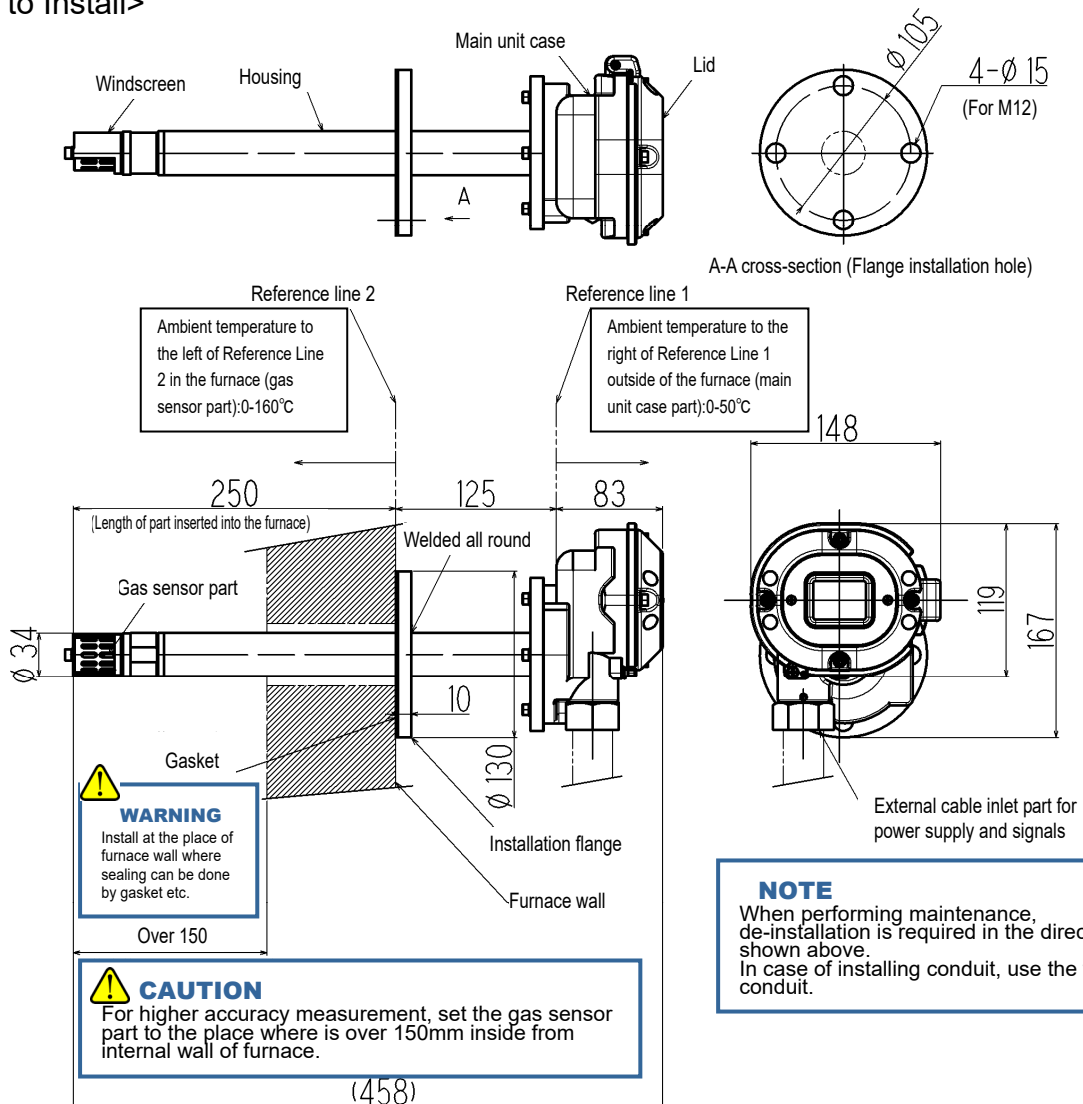

4-5. How to wire



CAUTION

- Be careful not to damage the internal components when wiring. In addition, be careful not to apply stresses on the detector head when (overweight) cables are installed.
- The connecting cables must not be installed together with the motor power cables, etc. When the cables must be installed together for unavoidable reasons, put the connecting cables in a metal conduit. The conduit must be connected to a grounding circuit.
- When stranded wires are used, prevent wires from contacting each other.
- Use the dedicated handling lever to wire.

<Recommended Cable>

CVV1.25 mm² - 4-core

<Parts. length table of outside conductor lead-in>

The parts for the external cable inlet are different from specifications. Use the appropriate parts, referring to the following lists.

Export Specification

Cable overall outer diameter(mm)	Rubber seal inner diameter(mm)	Washer inner diameter(mm)	Clamp inner diameter(mm)
From $\Phi 9.6$ to less than $\Phi 10.5$	$\Phi 11$	$\Phi 12$	$\Phi 10.8$
From $\Phi 10.5$ to less than $\Phi 11.5$	$\Phi 12$	$\Phi 12$	$\Phi 11.8$
From $\Phi 11.5$ to less than $\Phi 12.5$	$\Phi 13$	$\Phi 14$	$\Phi 12.8$
From $\Phi 12.5$ to less than $\Phi 13.0$	$\Phi 13.5$	$\Phi 14$	$\Phi 13.8$

Japan Specification

Cable overall outer diameter(mm)	Rubber seal inner diameter(mm)	Washer inner diameter(mm)
From $\Phi 9.6$ to less than $\Phi 11.0$	$\Phi 11$	$\Phi 12$
From $\Phi 11.0$ to less than $\Phi 11.5$	$\Phi 12$	$\Phi 12$
From $\Phi 11.5$ to less than $\Phi 12.0$	$\Phi 12$	$\Phi 14$
From $\Phi 12.0$ to less than $\Phi 13.0$	$\Phi 13$	$\Phi 14$
$\Phi 13.0$	$\Phi 13.5$	$\Phi 14$

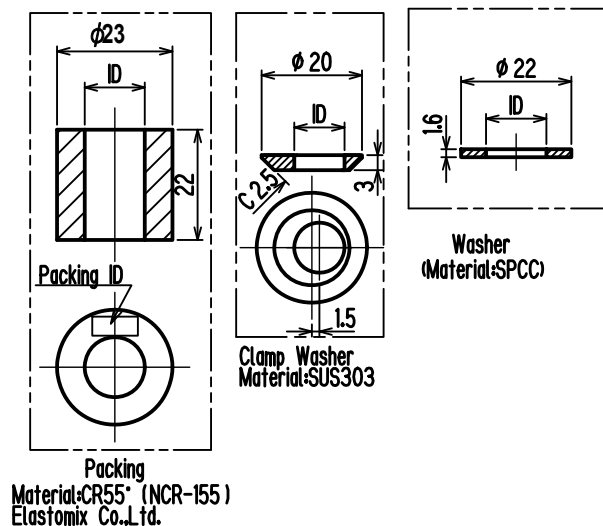

<Figure of Terminal Plate>

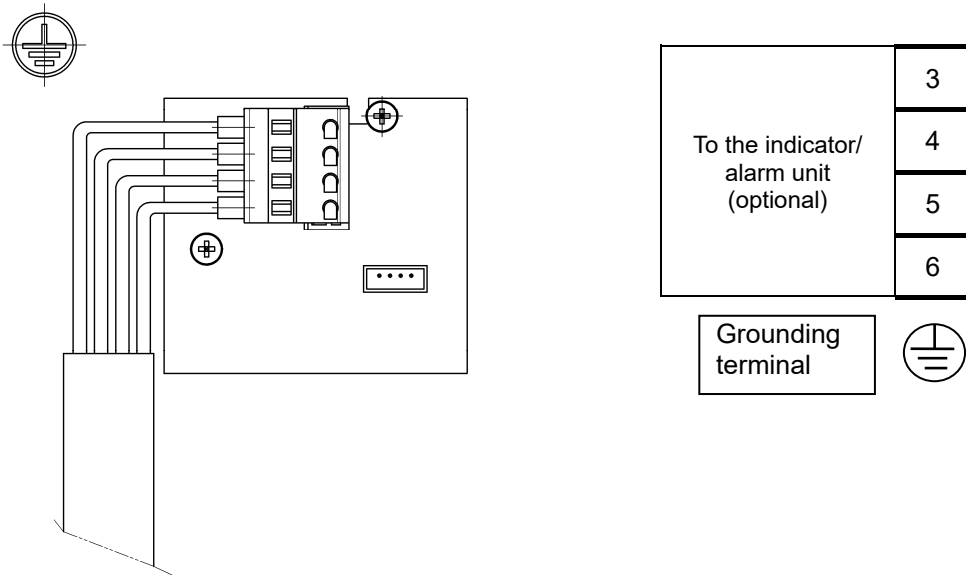

<Specifications of Terminal Plate>

Specifications of terminal plate

- Rated voltage: 250 VAC
- Rated current: 12 A
However, it depends on cables to be used.

Connection conditions

- Cables: 0.08 - 2.5 mm²
- Bare wire length: 8 - 9 mm
- Connecting tool: Dedicated handling lever (accessory)



CAUTION

The specified bare wire length must be observed when the wire insulation is peeled off.
 Improper clamping of the wire due to a shorter bare wire length may cause defective electric conduction or heating.
 Catching the wire insulation due to a shorter bare wire length may cause defective electric conduction or heating.
 Exposing the wire due to a longer bare wire length may cause defective insulation or a short circuit.
 Be careful not to break up the wire. If the wire is broken up when inserted to the terminal, this may cause defective insulation or heating.

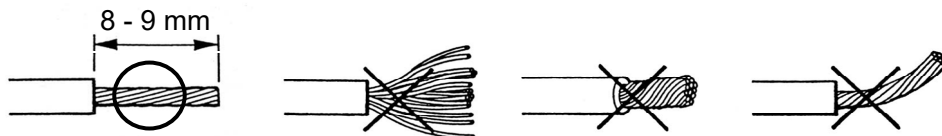

Compatible bar terminal

For a bar terminal, the following items are available.

- Bar terminal (ferrule): Model 216 Series (manufactured by WAGO)
- Crimping tool: Model VarioCrimp 4 (206-204) (manufactured by WAGO)



CAUTION

A bar terminal of the specified model must be used. Using other bar terminals invalidates the warranty of the performance.

<How to Connect to Terminal Plate>

When cables are connected to the connectors, use the dedicated lever or a flathead screwdriver to do it as shown below.



CAUTION

The right tools must be used.

In principal, one wire can be connected to one wiring hole.

When the wire is inserted into the driver slot by mistake, it does not contact the conductive part. This may cause defective electric conduction or heating.

When the wire is inserted under the spring by mistake, it does not contact the conductive part. This may cause defective electric conduction or heating.

NOTE

<How to Use the Dedicated Handling Lever>

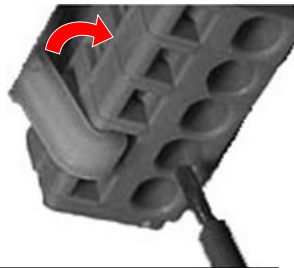

Push the lever with your finger to lower the spring in its inside.

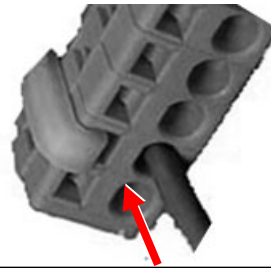

While holding down the lever, insert the wire into the (round) wiring hole until it reaches the deepest point.

To check whether the wire is connected securely, pull the wire gently. (Do not pull the wire strongly.)

<Attaching External Cable>

The way to attach the external cable is different from specifications. Attach the external cable appropriately, referring to the following information.

Export Specification

Attach the parts in the following order: cable gland, eccentric washer, washer, and rubber seal to the cable, then connect the cable into the main unit and screw the cable gland to tighten the rubber seal.

Japan Specification

Attach the parts in the following order: cable gland, washer, and rubber seal to the cable, then connect the cable into the main unit and screw the cable gland to tighten the rubber seal.

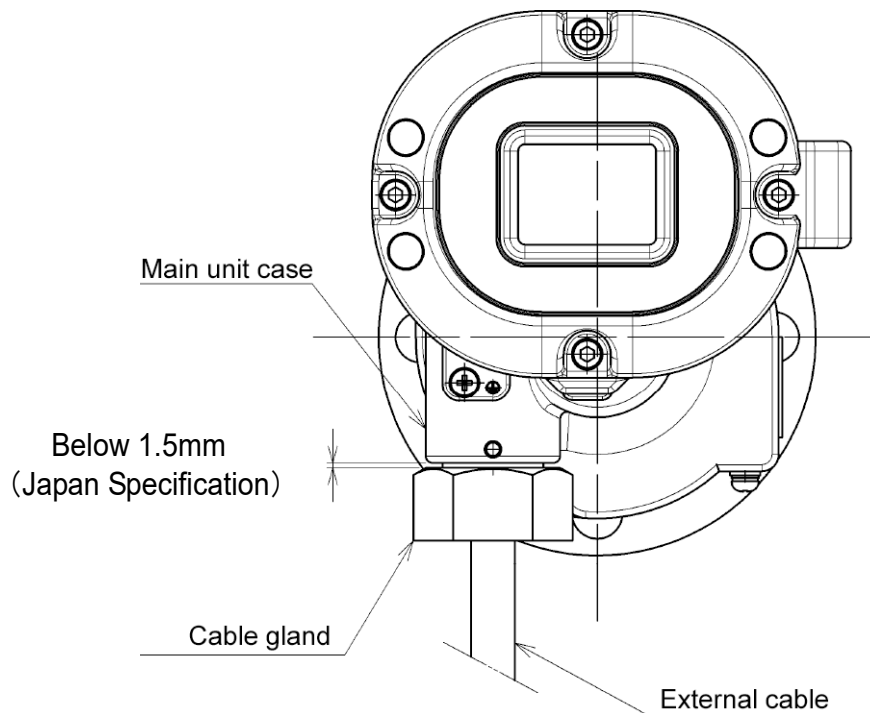

CAUTION

- Export Specification:
Ensure the tightening torque for the cable gland and seal plug to be 40 N·m or larger.
- Japan Specification:
Tighten a cable gland with a tool until a clearance between the cable gland and a main unit case is below 1.5 mm.
- If it is difficult to tighten the cable gland, grease its screw part and then tighten it with the tool.

<Grounding>

Connect the detector head to your grounding terminal with the external terminal .



WARNING

- Before turning on the detector head, do not forget to connect it to a grounding terminal.
- For stable operation of the detector head and safety, it must be connected to a grounding terminal. Do not connect the grounding wire to a gas pipe.
- The grounding must be made as D type grounding (below 100 Ω of grounding resistance).

<Wiring Example>

Connecting to the indicator/alarm unit (optional)

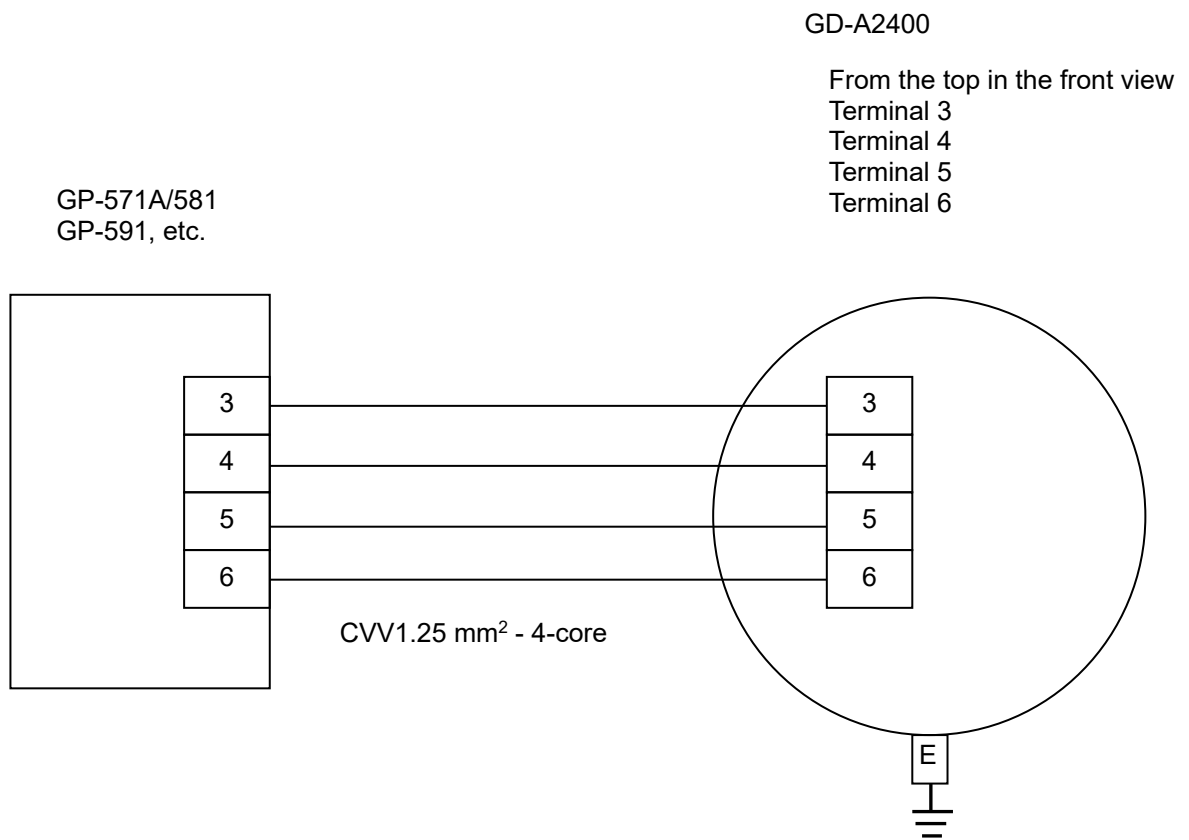

5

How to Operate

5-1. Preparation for start-up

Before supplying power, read and understand the following precautions. Ignoring these precautions may cause an electric shock or damage the detector head.

- Check that the detector head is installed properly.
- Connect the detector head to a grounding circuit.
- Check that the wiring is connected to external device properly.

NOTE

Read also the operating manual of the indicator/alarm unit (optional).

5-2. How to start the detector head

- Since the detector head has no power switch, turn on the power of the indicator/alarm unit (optional) to turn it on.
- After the indicator/alarm unit (optional) completes the initial clear operation, it enters the detection mode swiftly.



CAUTION

After the warm-up is completed, perform a gas calibration.

5-3. How to exit

To turn off the detector head, turn off the power of the indicator/alarm unit (optional).



WARNING

- When the detector head is turned off, an alarm may be activated on the upper (central) system. Before turning off the detector head, perform proper processing on the upper (central) system.
- Decide whether the power can be turned off by checking the operations of the devices connected to the indicator/alarm unit (optional).

6

Maintenance

This is an important instrument for the purpose of safety.

To maintain the performance of the detector head and improve the reliability of safety, perform a regular maintenance.

NOTE

Perform a regular maintenance on the detector head together with the indicator/alarm unit (optional).

6-1. Maintenance intervals and items

- Daily maintenance: Perform maintenance before beginning to work.
- Monthly maintenance: Perform maintenance on the alarm circuit (alarm test) once a month.
- Regular maintenance: Perform maintenance once or more for every six months to maintain the performance as a safety unit.

Maintenance item	Maintenance content	Daily maintenance	Monthly maintenance	Regular maintenance
Power Supply Check	Check that the power lamp lights up.	○	○	○
Concentration Display Check	Check that the concentration display value is zero. When the reading is incorrect, perform the zero adjustment after ensuring that no other gases exist around it.	○	○	○
Alarm Test	Check the alarm circuit by using the alarm test function.	-	○	○
Span Adjustment	Perform the sensitivity calibration by using the calibration gas.	-	-	○
Gas Alarm Check	Check the gas alarm by using the calibration gas.	-	-	○

<About Maintenance Services>

- We provide services on regular maintenance including span adjustment, other adjustments and maintenance.
To make the calibration gas, dedicated tools, such as a gas cylinder of the specified concentration and gas sampling bag must be used.
Our qualified service engineers have expertise and knowledge on the dedicated tools used for services, along with other products. To maintain the safety operation of the detector head, please use our maintenance service.
- The followings are typical maintenance services. For more information, please contact RIKEN KEIKI.

Main Services

Power Supply Check	:	Checks the power supply voltage. Verifies that the power lamp lights up. (Verifies that relevant points can be identified on the system.) (When a UPS (uninterruptible power system) is used, checks the operation with the UPS.)
Concentration Display Check	:	Verifies that the concentration display value is zero by using the zero gas. Performs the zero adjustment if the reading is incorrect.
Alarm Test	:	Inspects the alarm circuit by using the alarm test function. <ul style="list-style-type: none"> • Checks the alarm lamps. (Checks each activation of ALM1 and ALM2.) • Checks the external alarm. (Checks the activation of the external alarm, such as a buzzer.)
Span Adjustment	:	Performs the sensitivity calibration by using the calibration gas.
Gas Alarm Check	:	Checks the gas alarm by using the calibration gas. <ul style="list-style-type: none"> • Checks the alarm. (Checks the alarm activation when the alarm setpoint is reached.) • Checks the delay time. (Checks time to delay until the alarm is triggered.) • Checks the alarm lamps. (Checks each activation of ALM1 and ALM2.) • Checks the external alarm. (Checks the activation of external alarms, such as a buzzer and reset signal.)
Cleaning and Repair of the Gas Monitor (visual diagnosis)	:	Checks dust or damage on surface, cover, or internal parts of the detector head, clean and repair such parts of the detector head. Replaces parts which are cracked or damaged.
Replacement of Consumable Parts	:	Replaces consumable parts, such as a sensor.

<Cleaning of Detector>

Clean the detector head if it becomes extremely dirty. The detector head must be turned off while cleaning it. Use a waste cloth to remove dust. Do not use water or organic solvent for cleaning because they may cause malfunctions.

6-2. Gas calibration method

Perform a gas calibration using the calibration gas.

- Zero adjustment gas
- Span adjustment gas (collected in a gas sampling bag)
- Gas sampling bags

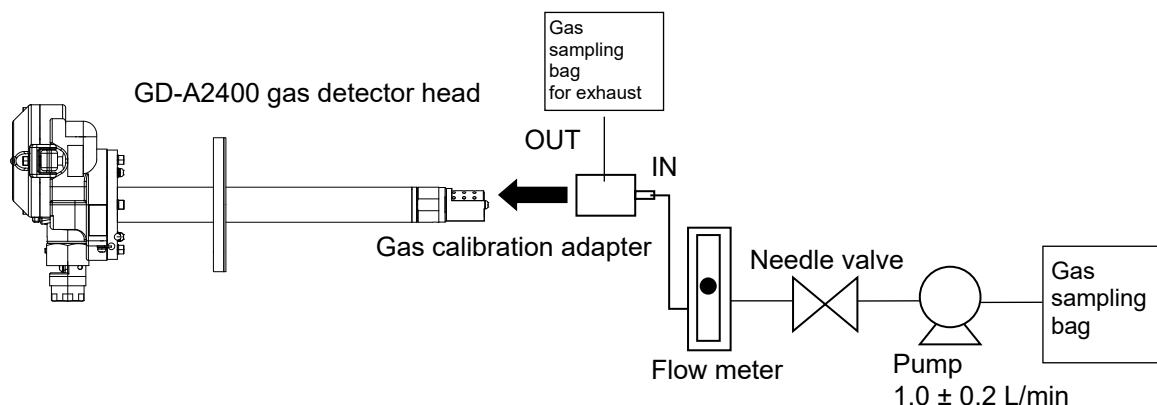

Perform the zero adjustment and the span adjustment on the indicator/alarm unit (optional).



CAUTION

Before starting the span adjustment, provide the detector head with the span adjustment gas and wait until the indicator is stabilized.

NOTE

Read also the operating manual of the indicator/alarm unit (optional).

6-3. Parts replacement

<Sensor Replacement>

Our service engineers need to replace the sensor and perform the gas calibration. Please contact RIKEN KEIKI.

NOTE

The gas calibration using the standard gas is required after the sensor is replaced. Please request it to RIKEN KEIKI.

<Replacement of Regular Replacement Parts>

List of recommended regular replacement parts

No.	Item	Maintenance intervals	Replacement intervals (year)	Quantity (pieces/unit)
1	O-ring (for the housing joint surface)	1 year	3 - 6 years	1
2	Rubber seal (for flange installation)	1 year	3 - 6 years	1

NOTE

- The above replacement intervals are recommendation only. The intervals may change depending on the operating conditions. These intervals do not mean the warranty periods either. The result of the regular maintenance may determine when to replace the parts.

7

Storage, Relocation and Disposal

7-1. Procedures to store the detector head or leave it for a long time

The detector head must be stored under the following environmental conditions.

- In a dark place under the normal temperature and humidity away from direct sunlight
- In a place where gases, solvents or vapors are not present

7-2. Procedures to relocate the detector head or use it again

When the detector head is relocated, select a new place in accordance with "4-2. Precautions for installation points" and "4-4. How to install".

For information on wiring, see "4-5. How to wire". The unpowered time must be minimized when the detector head is relocated.



CAUTION

When using a relocated or stopped/stored detector head again, do not forget to perform a gas calibration. For information on readjustment including a gas calibration, please contact RIKEN KEIKI.

7-3. Disposal of products

When the detector head is disposed of, it must be treated properly as an industrial waste in accordance with the local regulations.

8

Troubleshooting

The Troubleshooting does not explain the causes of all the malfunctions which occur on the detector head. This simply helps to find the causes of malfunctions which frequently occur. If the detector head shows a symptom which is not explained in this manual, or still has malfunctions even though remedial actions are taken, please contact RIKEN KEIKI.

NOTE

Read also the operating manual of the indicator/alarm unit (optional).

<Abnormalities on the Detector Head>

Symptom/Display	Causes	Actions
<u>The power of the indicator/alarm unit (optional) cannot be turned ON.</u>	The wiring is not correct.	Connect the wiring properly.
	Cable abnormalities (open circuit/not connected/short circuit)	Check the wiring of detector head and related devices around it.
<u>Abnormal operations of the indicator/alarm unit (optional)</u>	Disturbances by sudden surge noise, etc.	Turn off and restart the detector head. If such a symptom is observed frequently, take appropriate measures to eliminate the noise.
<u>Fault alarm activation of the indicator/alarm unit (optional)</u>	The cable is not connected or improperly connected.	Check if the cable is securely fastened to the terminal plate.
	Faults of the sensor	Replace the sensor with a new one.

<Abnormalities of Indicator/Alarm Unit Readings>

Symptoms	Causes	Actions
<u>The reading rises (drops) and it remains so.</u>	Drifting of sensor output	Perform the zero adjustment.
	Environmental changes	When the sensor ambient temperature rises (or drops), the "zero point" drops (or rises), but this is not a malfunction. Perform the zero adjustment at the operating temperature.
<u>A gas alarm is triggered despite of no gas leak and no other abnormalities at the detection point.</u>	Disturbance by noise	Turn off and restart the detector head. If such a symptom is observed frequently, take appropriate measures to eliminate the noise.
	Sudden change in the environment	When the environment (temperature, etc.) changes suddenly, the detector head cannot adjust to it and is affected by it. In some cases, the detector head triggers an indication alarm. Because the detector head cannot be used under sudden and frequent environmental changes, the user should take some preventive actions to eliminate them.
<u>Slow response</u>	Deteriorated sensor sensitivity	Replace the sensor with a new one.

9

Product Specifications

9-1. List of specifications

<ATEX/IECEX Specification>

Detection principle	Catalytic combustion type
Gas to be detected	Combustible gas
Detection method	Direct insertion type
Transmission system	Sensor direct output
Transmission cable	CVV, etc. (1.25mm ²) - 4-core
Cable connecting port	Pressure proof packing gland (Compatible cables Φ 9.6 to Φ 10.5 mm in outer diameter)
Operating temperatures	Sensor part: 0~+160°C (at a constant condition) Main unit case part: -20~+60°C (at a constant condition)
Structure	Direct insertion type
Explosion-proof structure	Flame-proof enclosures
Explosion-proof class	II 2 G Ex db IIC T3 Gb(ATEX) / Ex db IIC T3 Gb(IECEX)
External dimensions	Approx. 148 (W) x 167 (H) x 458 (D) mm (projection portions excluded)
Weight	Approx. 4.6 kg
Outer color	Munsell 7.5BG5/2

<Japan Ex Specification>

Detection principle	Catalytic combustion type
Gas to be detected	Combustible gas
Detection method	Direct insertion type
Transmission system	Sensor direct output
Transmission cable	CVV, etc. (1.25mm ²) - 4-core
Cable connecting port	Pressure proof packing gland (Compatible cables Φ 9.6 to Φ 10.5 mm in outer diameter)
Operating temperatures	Sensor part: 0~+160°C (at a constant condition) Main unit case part: 0~+50°C (at a constant condition)
Structure	Direct insertion type
Explosion-proof structure	Flame-proof enclosures
Explosion-proof class	Ex d IIC T3
External dimensions	Approx. 148 (W) x 167 (H) x 458 (D) mm (projection portions excluded)
Weight	Approx. 4.6 kg
Outer color	Munsell 7.5BG5/2

* Specifications subject to changes without notice.

9-2. List of accessories

- Operating manual 1sheet
- Dedicated handling lever 1pce.
- Flange gasket 1pce.
- Exhaust air direction nameplate 1pce.

9-3. Detection principle

When a combustible gas burns on the surface of a highly active oxidation catalyst in catalytic combustion, the contact burning-type sensor measures resultant temperature changes by measuring the resistance changes in the heat-resistant alloy wire coil.

The sensor consists of two elements: A detecting element having a heat-resistant alloy wire coil with an ultrafine particle oxidation catalyst sintered on it together with a carrier and a temperature-compensating element with a mixture of gas-inert alumina and glass sintered on it.

When a combustible gas comes into contact with the surface of the detecting element with oxidation catalyst sintered on it, the gas burns, causing the temperature to rise. In accordance with this temperature change, there occurs a change in the resistance of a heat-resistant alloy wire coil that constitutes the element. These resistance values are approximately proportional to gas concentrations. From the changes in the resistance values, potential differences are obtained using a bridge circuit and displayed as gas concentrations on the meter.

[Structure]

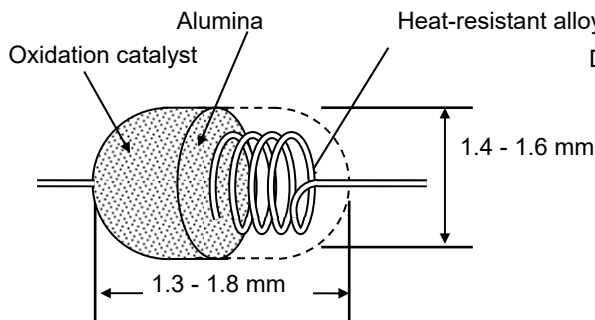

[Principle]

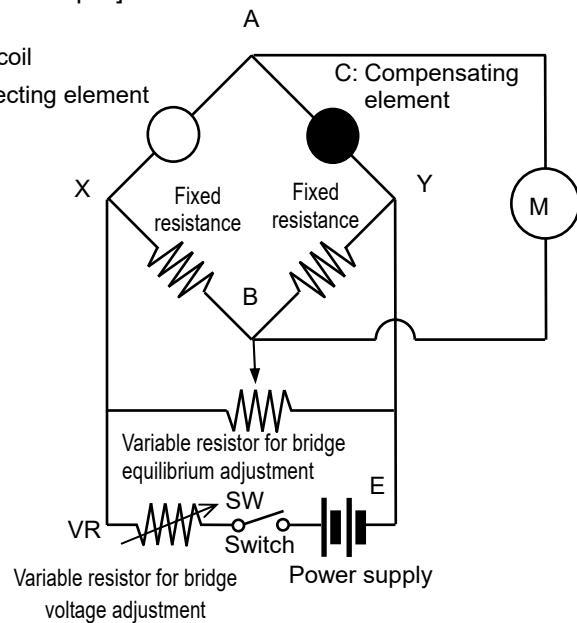

10

Definition of Terms

Catalytic combustion type	This is a principle of the sensor installed in the detector head. See "9-3. Detection principle" for details.
Initial clear	Output from the detector head fluctuates for a while after turning on the power. This is a function to prevent triggering alarm during that time.
Full scale	Maximum value of the detection range.
%LEL	A unit which the lower explosive limit (LEL) of the combustible gas to be detected is set to 100.
Calibration	Adjusts the readings to the calibration gas concentration value by using the calibration gas.



EU-Declaration of Conformity

Document No.: 320CE23019



We, RIKEN KEIKI Co., Ltd. 2-7-6, Azusawa, Itabashi-ku, Tokyo, 174-8744, Japan declare under our sole responsibility that the following product conforms to all the relevant provisions.

Product Name: Furnace Gas Detector Head
Model: GD-A2400

Council Directives		Applicable Standards
2014/34/EU	ATEX Directive	EN IEC 60079-0:2018 EN 60079-1:2014
2014/30/EU	EMC Directive	EN 50270:2015
2011/65/EU ^[1]	RoHS Directive	EN IEC 63000:2018

^[1]Including substances added by Commission Delegated Directive (EU) 2015/863

EU-Type examination Certificate No. DEKRA 11ATEX0095 X

Notified Body for ATEX DEKRA Certification B.V. (NB 0344)
Meander 1051, 6825 MJ Arnhem
P.O. Box 5185, 6802 ED Arnhem
The Netherlands

Auditing Organization for ATEX DEKRA Certification B.V. (NB 0344)
Meander 1051, 6825 MJ Arnhem
P.O. Box 5185, 6802 ED Arnhem
The Netherlands

The marking of the product shall include the following:

 II 2 G Ex db IIC T3 Gb

Place: Tokyo, Japan

Date: Jan. 19, 2024

Takakura Toshiyuki
General manager
Quality Control Center