



# **Fixed type Oxygen Detector Head GD-1DOX-AS**

**Operating Manual  
(PT2-183)**

**RIKEN KEIKI Co., Ltd.**

2-7-6 Azusawa, Itabashi-ku, Tokyo, 174-8744, Japan

Phone : +81-3-3966-1113

Fax : +81-3-3558-9110

E-mail : [intdept@rikenkeiki.co.jp](mailto:intdept@rikenkeiki.co.jp)

Web site : <https://www.rikenkeiki.co.jp/>

## Operating Precautions

The detector detects oxygen in the atmosphere and prevents acid-deficient accidents due to acid-deficient air release or accidents due to excessive oxygen.

Please fully understand the following points before using it, so that it can be used properly.

1. The detector may be interfered by gases and vapors other than oxygen in the atmosphere. In addition, it may be fluctuated by environmental (temperature, humidity etc.) changes in the installation site.
2. The detector is affected by pressure. If the detector is used at a pressure other than atmospheric pressure, a calibration is required under that pressure. The maximum allowable pressure is 110 KPa. The detector cannot be used under reduced pressure.
3. The gas sensor used by the detector contains an electrolyte. Electrolyte may cause severe skin burns if it contacts skin, while it may cause blindness if its contacts eyes. Do not touch the sensor directly in the event of a liquid leak.
4. For maintenance of the detector, it must go through a regular maintenance, including replacement and adjustment of the regular replacement parts as specified in the operating manual. In addition, because this is a safety unit, it is recommended that a regular maintenance and span adjustment are performed every six months.

---

## <Contents>

1 Outline of the Product.....	2
1-1. Preface.....	2
1-2. Purpose of use.....	2
1-3. Definition of DANGER, WARNING, CAUTION and NOTE.....	2
2 Important Notices on Safety.....	3
2-1. Danger cases.....	3
2-2. Warning cases.....	4
2-3. Precautions.....	5
2-4. Safety Information.....	6
3 Product Components.....	7
3-1. Main unit and standard accessories.....	7
3-2. Names and functions for each part.....	8
4 How to Use.....	10
4-1. Before using the gas detector.....	10
4-2. Precautions for installation sites.....	10
4-3. Precautions for system designing.....	11
4-4. How to install.....	12
4-5. Installation procedure.....	13
4-6. How to wire.....	14
4-7. How to tube.....	17
5 How to Operate.....	18
5-1. Preparation for start-up.....	18
5-2. Basic operating procedures.....	18
5-3. How to start the gas detector.....	19
5-4. Flow Rate Adjustment.....	20
5-5. How to exit.....	20
6 Maintenance.....	21
6-1. Maintenance intervals and items.....	21
6-2. Calibration method.....	23
6-3. Replacement parts.....	26
7 Storage, Relocation and Disposal.....	27
7-1. Procedures to store the gas detector or leave it for a long time.....	27
7-2. Procedures to relocate the detector or use it again.....	27
7-3. Disposal of products.....	27
8 Troubleshooting.....	28
9 Product Specifications.....	29
9-1. List of specifications.....	29
9-2. Detection principle.....	30
10 Definition of Terms.....	31

## 1

# Outline of the Product

## 1-1. Preface

Thank you for choosing our fixed type oxygen detector head GD-1DOX-AS. Please check that the model number of the product you purchased is included in the specifications on this manual.



This manual explains how to use the detector and its specifications. It contains information required for using the gas detector properly. Not only the first-time users but also the users who have already used the product must read and understand the operating manual to enhance the knowledge and experience before using the detector.

Note that the detector cannot be used alone. Use it with the dedicated indicator/alarm unit. Be sure to read the operating manual of the indicator/alarm unit as well.

## 1-2. Purpose of use

- This detector is a fixed type gas detector head that detects oxygen and performs the alarm activation when the gas concentration is over the setting value.
- The detector is a safety unit, not an analyzer or densitometer which performs quantitative/qualitative analysis/measurement for gases. Please fully understand the features of the detector before using it, so that it can be used properly.
- Use the detector in combination with an indicator/alarm unit that indicates an oxygen concentration and triggers an alarm.
- The detector draws a gas by an aspirator using compressed air to perform gas detection.

## 1-3. Definition of DANGER, WARNING, CAUTION and NOTE

 <b>DANGER</b>	This message indicates that improper handling may cause serious damage on life, health or assets.
 <b>WARNING</b>	This message indicates that improper handling may cause serious damage on health or assets.
 <b>CAUTION</b>	This message indicates that improper handling may cause minor damage on health or assets.
<b>NOTE</b>	This message indicates advice on handling.

---

## 2

---

# Important Notices on Safety

## 2-1. Danger cases



### **DANGER**

#### About explosion-proof

- The window plate material is a polycarbonate resin. Do not use organic solvents and alkali types (liquid or vapor). It may cause the color and shape of the window plate to be changed.
- Do not open the lid when applying current.
- Do not attempt to repair the detector.
- For the lid, use hexagon socket head bolts specified by RIKEN KEIKI.
- Do not apply a strong force or shock to the window plate. The explosion-proof performances may be deteriorated due to damages. The explosion protection condition for the detector is "low (2J)" possibility of mechanical damage.  
Ambient temperature: -20 to +53°C  
(The ambient temperature on explosion-proof certification is described above and it indicates the temperature range which can maintain the explosion-proof performance and not the product performance, see "9-1. List of specifications" for details.)
- Do not replace parts at your sole discretion but contact RIKEN KEIKI if the transparent window has a crack or the explosion-proof joint surface is abnormal, or the clamping screw or bolt is changed, lost etc.
- Do not repair the explosion-proof joint surface.
- Be careful not to hit sharp tools against the window plate.

## 2-2. Warning cases



### WARNING

#### Need of grounding circuit

Do not cut the grounding circuit or disconnect the wire from the grounding terminal.

#### Defects in protective functions

Before starting the detector, check the protective functions for defects. When seeming defects are found in the protective functions, such as protective grounding, do not start the detector.

#### Tubing

The detector is designed to draw gases around it under the atmospheric pressure. Be sure that excessive pressure is not applied to the sampling inlet and outlet (GAS IN, GAS OUT) of the detector. Detected gases must be exhausted from the detected gas exhausting outlet (GAS OUT) to which an exhaust tube is connected, to a point regarded as a safe place.

#### Span adjustment (AIR adjustment) in atmosphere

When the span adjustment (AIR adjustment) is performed in the atmosphere, check the atmosphere for freshness before beginning the adjustment. If interference gases exist, the adjustment cannot be performed properly, thus leading to dangers when the oxygen concentration fluctuates.

#### Response to gas alarm

Issuance of a gas alarm indicates that there are extreme dangers. Take proper actions based on your judgment.

#### Handling of sensor

Do not disassemble the sensor used by the detector because it contains electrolyte. Electrolyte may cause severe skin burns if it contacts skin, while it may cause blindness if its contacts eyes. If electrolyte is adhered on your clothes, that part on your clothes is discolored or its material is

## 2-3. Precautions



### CAUTION

**Do not use a transceiver near the detector.**

Radio wave from a transceiver or other radio wave transmitting device near the detector or its cables may disturb readings. If a transceiver or other radio wave transmitting device is used, it must be used in a place where it disturbs nothing.

**Verify that the flow rate corresponds to the specified flow rate before using the detector.**

If it does not correspond to the specified flow rate, gas detection cannot be performed properly. Check whether the flow rate is unstable or lost.

**Attach the dust filter before using the detector.**

Before using the detector, attach the specified filter to prevent disturbances by possible gas adsorption or air dust.

A dust filter to be used varies depending on the gas to be detected. For more information on dust filters, please contact RIKEN KEIKI.

**Observe the operating restrictions to prevent condensation inside the tube.**

Condensation formed inside the tube causes clogging or gas adsorption, which may disturb accurate gas detection. Thus, condensation must be avoided. In addition to the installation environment, carefully monitor the temperature/humidity of the sampling point to prevent condensation inside the tube. In particular, when detecting a gas which is dissolved into water and corrodes contacted materials, such as a strong acid gas, the gas is undetectable and furthermore may corrode internal parts. Please observe the operating restrictions.

**Do not disassemble/modify the detector, or change the settings if not necessary.**

Disassembling/modifying the detector will invalidate the warranty of the performance. Changing the settings without understanding the specifications may cause alarm malfunctions. Please use the detector properly in accordance with the operating manual.

**Avoid applying organic solvents and others to the window plate for a long time.**

The window plate material is a polycarbonate resin. When organic solvents (liquid or highly-concentrated vapor) and others are applied to the plate for a long time, its color and shape may be changed.

**Never fail to perform a regular maintenance.**

Since this is a safety unit, a regular maintenance must be performed to ensure safety. Continuing to use the detector without performing a maintenance will deteriorate the sensitivity of the sensor, thus resulting in inaccurate gas detection.

## 2-4. Safety Information

### Necessary information for explosion proof construction of Model GD-1DOX.

When oxygen is detected, the unit outputs a voltage corresponding to the oxygen concentration, and the indicator/alarm unit instructs the concentration, and when the concentration becomes equal to or lower than a preset concentration level (or higher), the alarm is activated by the indicator/alarm unit.

<TIIS Specifications>

#### Technical Data

(Protection Method)	Flameproof enclosure
(Explosion-proof class)	Ex d IIC T6 X
(Ambient Temperature)*	-20°C to +53°C
(Electrical Data)	Detecting element output signal: DC0.1V 0.2mA
(Applicable Standard)	JNIOHS-TR-NO. 43(2008)

\*The ambient temperature on explosion-proof certification is described above and it indicates the temperature range which can maintain the explosion-proof performance and not the product performance, see “9-1. List of specifications” for details.

#### Installation

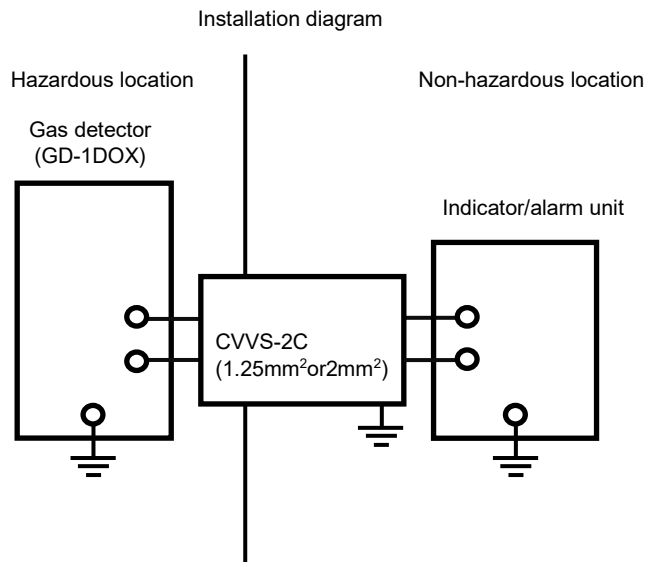



3

# Product Components

## 3-1. Main unit and standard accessories

<Main Unit>

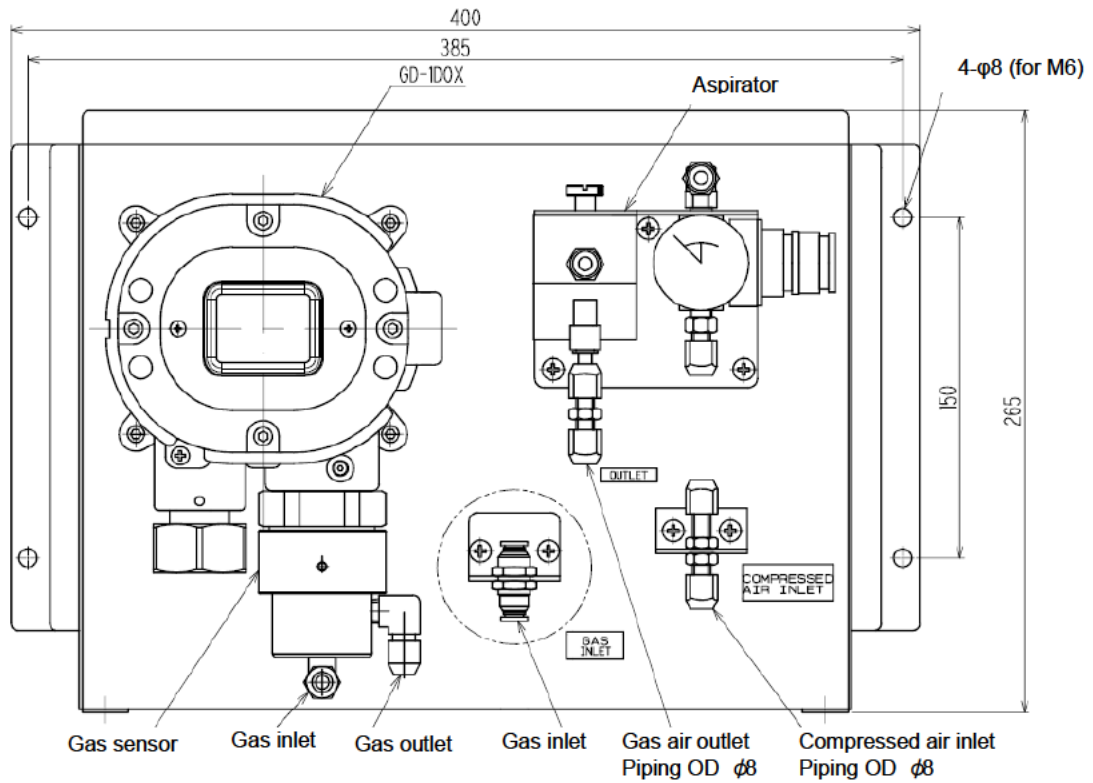

<Standard Accessories>

- Operating manual ..... one
- MC filter with flow monitor ..... one
- Hexagon wrench key ..... \*

\* The quantity supplied is the same as the number of certificates.

**NOTE**

This product is designed to have a gas detector head "GD-1DOX" incorporated in the sampling device. The internal tubing required for "GD-1DOX" has been arranged prior to shipment.

### 3-2. Names and functions for each part

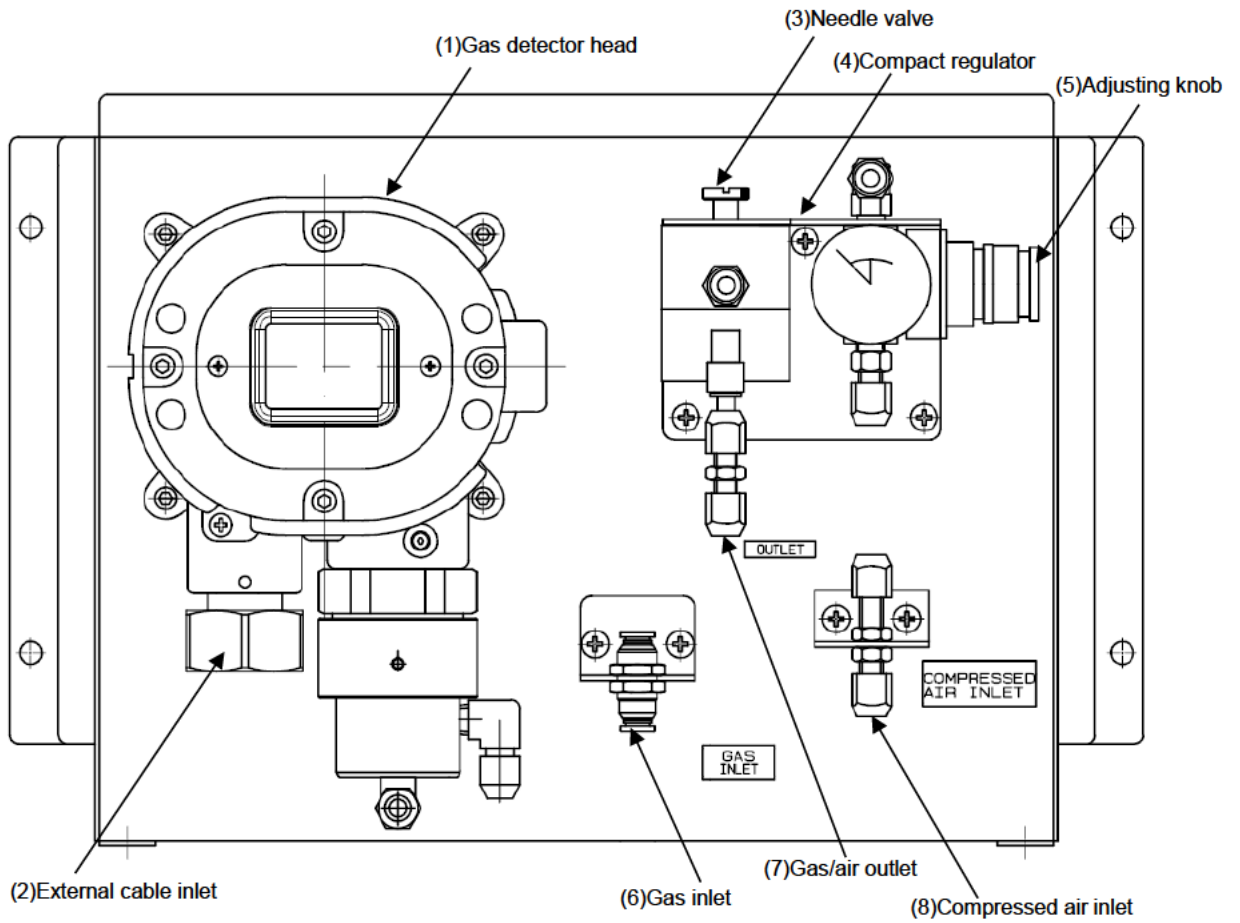

No.	Name	Function
(1)	Gas detector head	Detects a gas (applicable detector head: GD-1DOX).
(2)	External cable inlet	A port to draw a power and signal cables for the gas detector head.
(3)	Needle valve	Adjusts the amount of compressed air after reducing pressure.
(4)	Compact regulator	Reduces the pressure of supplied compressed air and displays a pressure value after the reduction.
(5)	Adjusting knob	A knob turned to reduce the pressure of supplied compressed air.
(6)	Gas inlet	An inlet for gases.
(7)	Gas/air outlet	An outlet for gases and compressed air.
(8)	Compressed air inlet	An inlet for compressed air.

<Tubing Diagram>

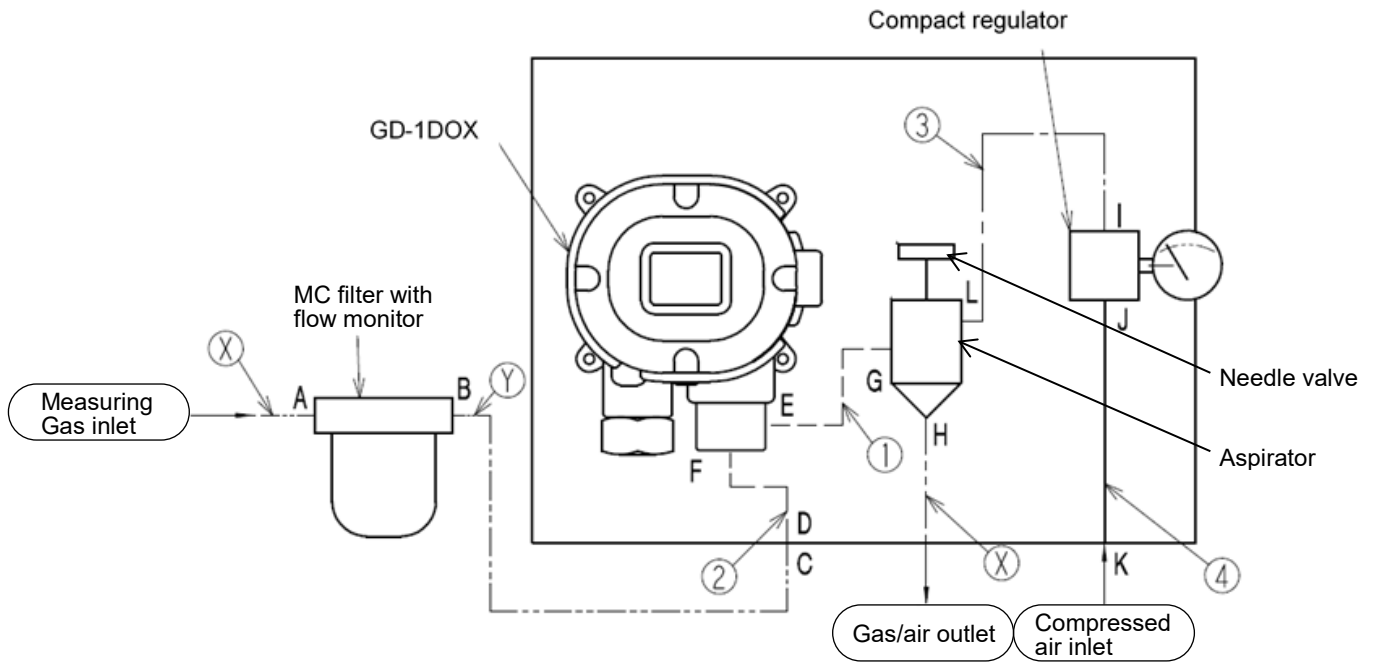

**Tubing specification**

\* The customer is required to provide the followings.

— · · · · · (Alternate long and two short dashed line)

Polyurethane tube (ø6 - ø8): X

Polyurethane tube (ø4 - ø6): Y

\* Internal tubing has been arranged already.

— — — — (Dashed line)

Polyurethane tube: ①

Polyurethane tube: ②

— · · · — (Alternate long and short dashed line)

Copper tube (ø4 - ø6): ③

———— (Solid line)

Copper tube (ø6 - ø8): ④

---

# 4

---

## How to Use

---

### 4-1. Before using the gas detector

Not only the first-time users but also the users who have already used the detector must follow the operating precautions.

Ignoring the precautions may damage the gas detector, resulting in inaccurate gas detection.

### 4-2. Precautions for installation sites



#### CAUTION

This is a precision device. Because the detector may not provide the specified performance in some places (environments), check the environment in the installation point, and then take appropriate actions if necessary.

Because the detector plays an important role for safety and disaster prevention, as many units of the detector as needed must be installed in appropriate points.

Because points where gases leak and remain easily are different depending on the types of gases and the working areas, please decide carefully on installation points and the number of units to be installed.

Do not install the detector in a place with vibrations or shocks.

The detector consists of sensitive electronic parts. The detector must be installed in a stable place without vibrations or shocks and it cannot drop.

Do not install the detector in a place exposed to water, oil or chemicals.

When selecting installation points, avoid a place where the detector is exposed to water, oil or chemicals.

Do not install the detector in a place where the range of operating temperatures is exceeded.

The detector must be installed in a stable place where the operating temperature is maintained and does not change suddenly.

<TIIS Specifications> -10 to +40°C

Do not install the detector in a place exposed to direct sunlight or sudden changes in the temperature.

When selecting installation points, avoid a place where it is exposed to direct sunlight or radiant heat (infrared rays emitted from a high-temperature object), and where the temperature changes suddenly. Condensation may be formed inside the detector, or the detector cannot adjust to sudden changes in the temperature.

Keep the detector (and its cables) away from noise source devices.

When selecting installation points, avoid a place where high-frequency/high-voltage devices exist.

Do not install the detector in a place where maintenance of the detector cannot be performed or where handling the detector involves dangers.

Regular maintenance of the detector must be performed.

Do not install the detector in a place where the machinery must be stopped when maintenance is performed in its inside, where parts of the machinery must be removed to perform maintenance, or where the detector cannot be removed because tubes or racks prevent access to it. Do not install the detector in a place where maintenance involves dangers, for example, near a high-voltage cable.

Do not install the detector in machinery which is not properly grounded.

Before installing the detector in machinery, the machinery must be grounded properly.

Do not install the detector in a place where interference gases exist around it.

The detector must not be installed in a place where interference gases exist around it.



**WARNING**

An oxygen detector is affected by pressure. If the detector is used at a pressure other than atmospheric pressure, a calibration is required under that pressure. The maximum allowable pressure is 110 KPa. The detector cannot be used under reduced pressure. Using the detector at a pressure exceeding the allowable range may cause a trouble in the oxygen sensor performance.

**4-3. Precautions for system designing**



**CAUTION**

An unstable power supply and noise may cause malfunctions or false alarms. The descriptions in this section must be reflected on the designing of a system using the detector.

Introducing protective measures against lightning

If cables are installed outside the factory/plant, or if internal cables are installed in the same duct as the cables coming from outside the factory/plant, "lightning" will cause problems. Because lightning acts as a large emission source while cables act as a receiving antenna, devices connected to the cables may be damaged.

Lightning cannot be prevented. Cables installed in a metal conduit or under the ground cannot be completely protected from inductive lightning surge caused by lightning. Although complete elimination of disasters caused by lightning is impossible, the following protective measures can be taken.

Protection against lightning	<p><u>Take appropriate measures in accordance with the importance of the facilities and the environment.</u></p> <ul style="list-style-type: none"> <li>• Provide protection by a lightning arrester (cable arrester). (Although inductive lightning surge can be transmitted through the cable, it is prevented by installing a lightning arrester before the field devices and central processing equipment. For information on how to use a lightning arrester, please contact the manufacturer.)</li> </ul>
Grounding	In addition to lightning, there are more sources of surge noise. To protect units from these noise sources, the units must be grounded.

\* The lightning arrester has a circuit to remove a surge voltage which damages field devices, so that signals may be attenuated. Before installing a lightning arrester, verify that it works properly.

## 4-4. How to install

<Installation Dimensions and Maintenance Space>

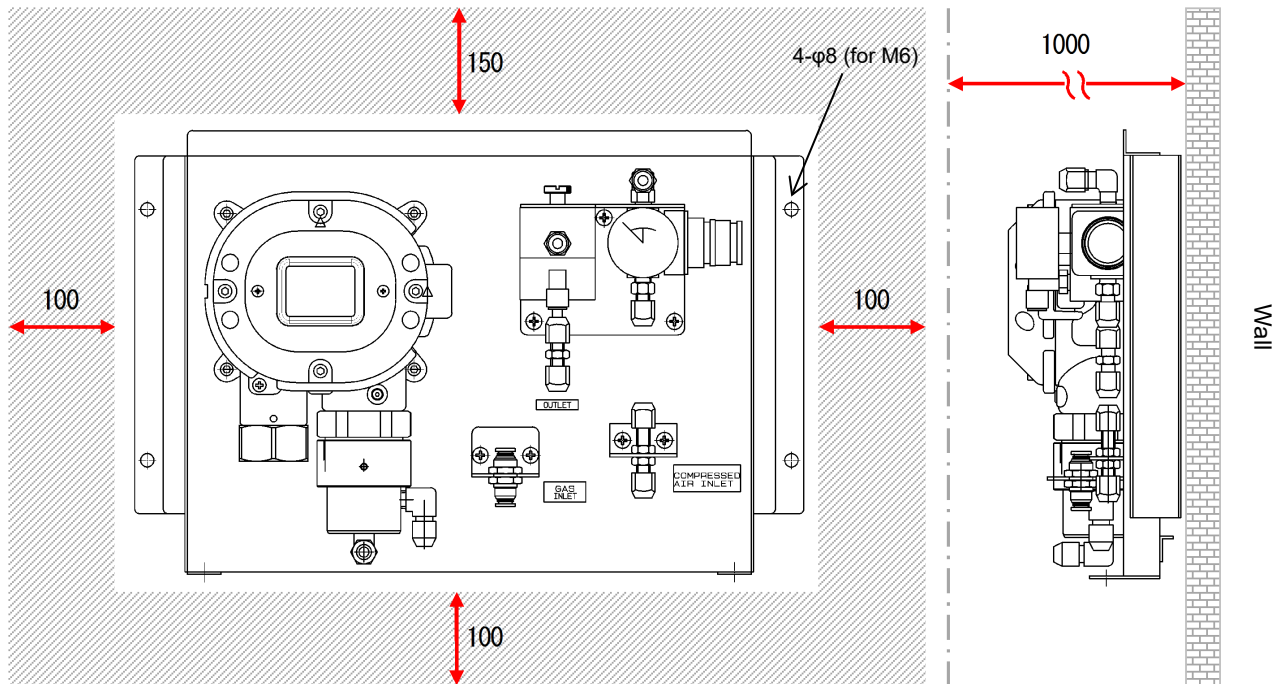

Unit: mm

The following installation requirements must be met to install the detector.

- Attach the detector on the wall and others using four M6 screws.



### CAUTION

- Do not install the detector in a place where maintenance of the detector cannot be performed or where handling the detector involves dangers.

Regular maintenance of the detector must be performed.

Do not install the detector in a place where the machinery must be stopped when maintenance is performed in its inside, where parts of the machinery must be removed to perform maintenance, or where the detector cannot be removed because tubes or racks prevent access to it. Do not install the detector in a place where maintenance involves dangers, for example, near a high-voltage cable.

- If the detector is to be fixed on a wall or the like, install it properly where can hold its weight.

### NOTE

- Hexagon socket head cap bolt with strength class "A2-70" are used.  
When you lost or replace it, we recommend that you ask our local sales office nearest you.
- Grease specified by RIKEN KEIKI : BARRIERTA JFE 552 (manufactured by NOK KLUBER)  
If you can not prepare the specified grease, use one that meets the following requirements.
  1. Material does not harden due to deterioration
  2. Volatile solvent-free
  3. Material does not cause corrosion at the surface
  4. Silicon-free
  5. Validation of suitability depends on the specifications of grease manufacturer

## 4-5. Installation procedure

Cable gland, Rubber seal, Washer and Eccentric washer are mounted on GD-1DOX main body as shown below.

Attach the parts :

Pass a Cable (e.g. CVVS) through the Cable gland, Eccentric washer, Washer, and Rubber seal, and drawn into detector inside. (For wire methods, see "4-6 How to wire".) When installing the cable gland, make sure that there is no dust in cable gland mounting part, hexagon socket set screw, grounding screw, and the cable gland. Then apply grease specified by RIKEN KEIKI.

Tightens Cable gland, and then tightens hexagon socket set screw (M4×6), and fix cable gland.

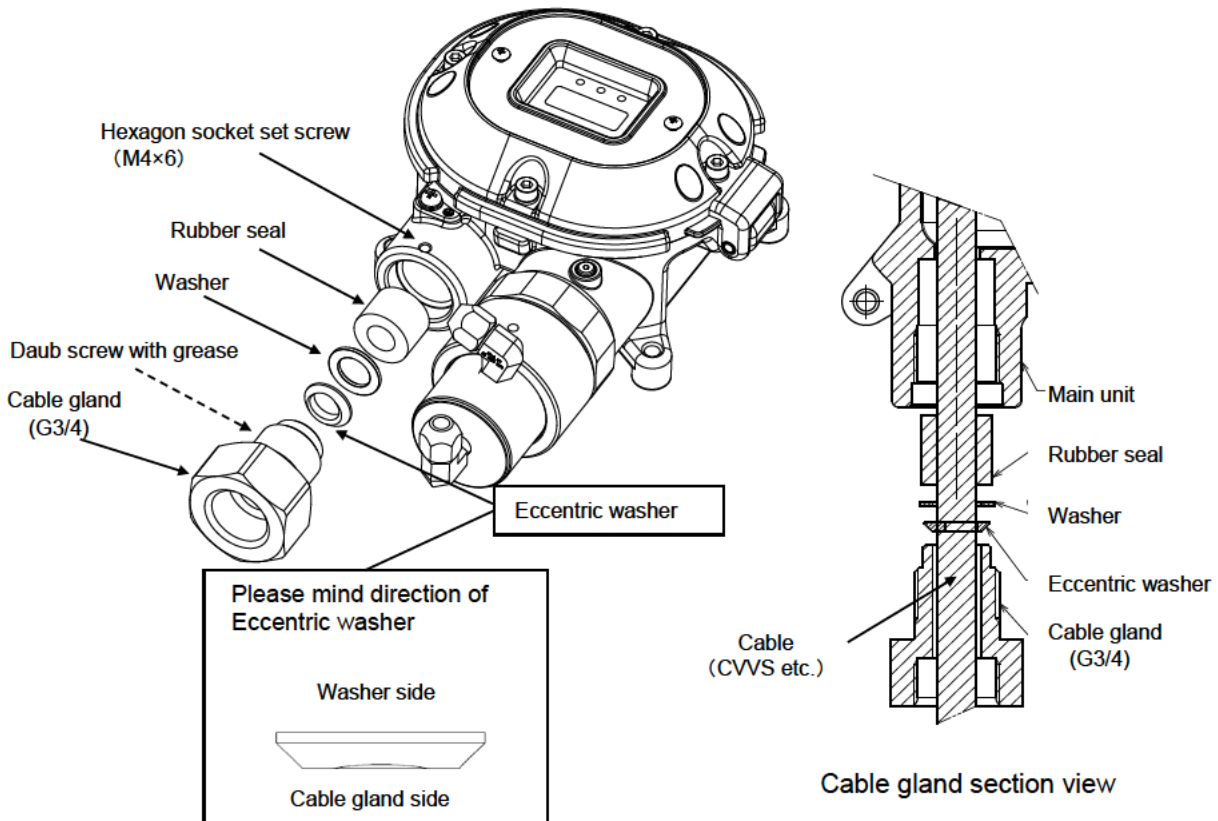

### WARNING

- If a scratch, crack or other abnormality is found on the container or explosion-proof structure joint surface, stop using the detector immediately and contact RIKEN KEIKI.



### CAUTION

- Tighten 40 N·m or larger torque value to ensure the tightening cable gland and seal plug.
- If it is difficult to tighten the cable gland, apply grease to the threaded part of the cable gland and then tighten it with a tool.

## 4-6. How to wire

### NOTE

- Before wiring, read also the operating manual of the indicator/alarm unit to be connected carefully.



### WARNING

- Draw the cable to the detector by the means that do not impair the explosion-proof performance.
- Connect the power to the indicator/alarm unit after all wiring work is completed. Wiring with the power connected may pose a risk of short circuit between terminals or electric shock.



### CAUTION

- Be careful not to damage the internal electronic circuit when wiring. In addition, be careful not to apply stresses on the detector when (overweight) cables are installed.
- The power cables and signal cables must not be installed together with the motor power cables etc. When these cables must be installed together for unavoidable reasons, put the power cables and signal cables in a metal conduit. The conduit must be connected to a grounding circuit.
- When stranded wires are used, prevent wires from contacting each other.
- Use appropriate cables to wire.

### <Recommended Cables>

- CVVS or equivalent cable (1.25 mm<sup>2</sup> or 2.0 mm<sup>2</sup>), 2-core
- The cable distance between the detector and indicator/alarm unit, please wire it at up to 600m.

### <Parts. length table of outside conductor lead-in>

Cable overall outer diameter(mm)	Rubber seal inner diameter(mm)	Washer inner diameter(mm)	Clamp inner diameter(mm)
From $\Phi 9.6$ to less than $\Phi 10.5$ (standard)	$\Phi 11$	$\Phi 12$	$\Phi 10.8$
From $\Phi 10.5$ to less than $\Phi 11.5$ (option)	$\Phi 12$	$\Phi 12$	$\Phi 11.8$
From $\Phi 11.5$ to less than $\Phi 12.5$ (option)	$\Phi 13$	$\Phi 14$	$\Phi 12.8$
From $\Phi 12.5$ to less than $\Phi 13.0$ (option)	$\Phi 13.5$	$\Phi 14$	$\Phi 13.8$

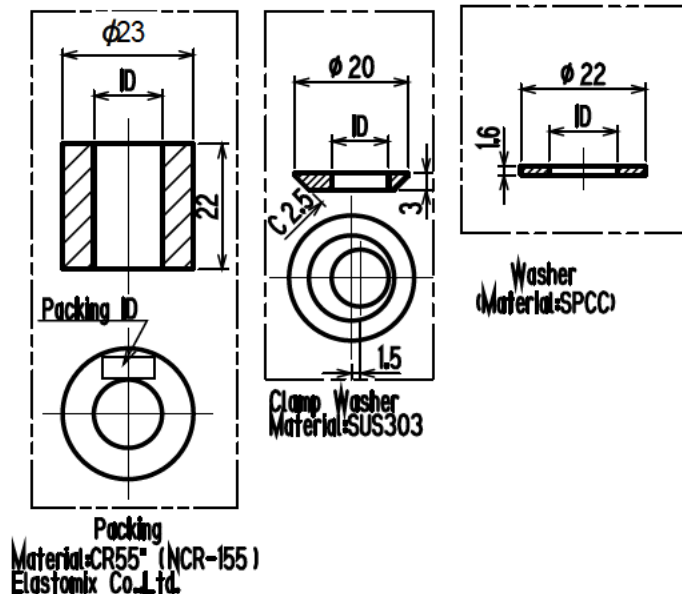



**NOTE**

- The following table shows an example of overall outer diameters of cables. Use them for reference. The overall outer diameters must be checked because they somewhat vary between manufacturers.

Number of core	CVV 1.25 mm <sup>2</sup>	CVV 2 mm <sup>2</sup>	CVVS 1.25 mm <sup>2</sup>	CVVS 2 mm <sup>2</sup>
2	ø9.5	ø10.5	ø10.0	ø11.0
3	ø10.0	ø11.0	ø10.5	ø11.5
4	ø10.5	ø11.5	ø11.0	ø12.0
5	ø11.5	ø12.5	ø12.0	ø13.0
6	ø12.5	ø13.5	ø13.0	ø14.0

When the four hexagon socket head bolts of the gas detector head "GD-1DOX" are loosened and the lid is opened, the following terminal plate appears. There is one protective grounding terminal on each side.

<Figure of Terminal Plate>

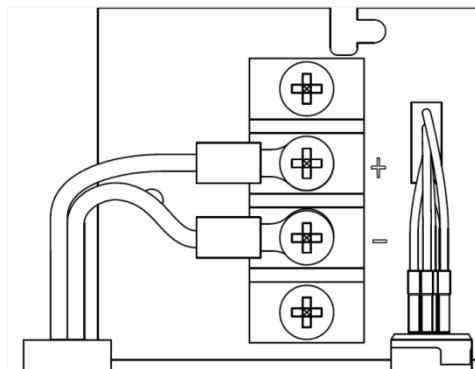

Torque value : Max. 1.2 N·m

<Compatible round terminal>

For a round terminal, the following items are available.  
 TEMV 1.25 – 4M  
 TEMV 2 – 4M



**CAUTION**

- A round terminal of the specified model must be used. Using other bar terminals invalidates the warranty of the performance.
- Be sure to use the terminal block cover.

## &lt;Grounding&gt;

Connect the detector to your grounding terminal with the external terminal .

**WARNING**

- Before turning on the detector, do not forget to connect it to a grounding terminal.
- For stable operation of the detector and safety, it must be connected to a grounding terminal. Do not connect the grounding wire to a gas pipe.
- The grounding must be made as D type grounding (below 100  $\Omega$  of grounding resistance).
- For the grounding wire, use cable lugs to safely connect it to a grounding terminal without looseness or twist.
- Use ring terminals to connect the grounding terminal with the ground and use the grounding wire with cross-sectional area of 4 mm<sup>2</sup> or more for the external grounding terminal.

## &lt;Wiring Example&gt;

Connecting to the indicator

Indicator/alarm unit  
terminal plate  
OX-5001 etc.

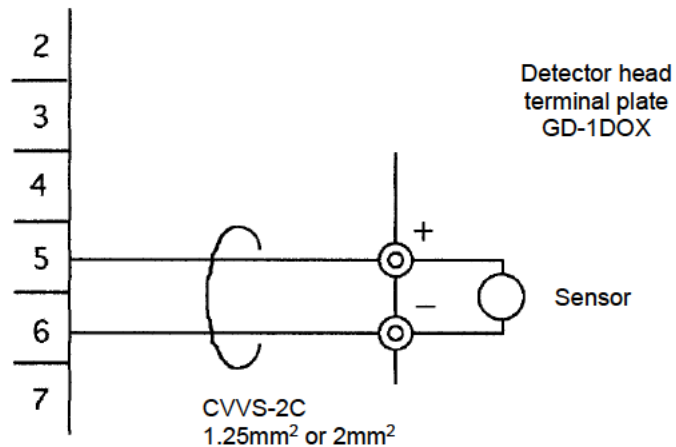

## 4-7. How to tube

The detector has a Rc1/8 thread inside of the sampling inlet/outlet (GAS IN, GAS OUT), the "PP" unions is normally attached. Because their material varies depending on the gas to be used, please specify the appropriate unions.

The compatible tube is a tube of  $\Phi 6$  (OD) -  $\Phi 4$  (ID). The tube must be installed with the supplied inners and sleeves attached to prevent a leak.

When the tube is cut, its cut point has a smaller inner diameter. Use a file etc. to expand the inner diameter of the cut point. To remove cut-dust remaining inside of the tube, blow compressed air into the tube before connecting it to the detector.

Some sample gases have highly adsorptive or corrosive property. Select the tube material taking into account of these precautions.

Be careful that the flow rate introduced to the detector is in the range of 0.8 - 2 L/min (the maximum pressure inside the flow path and sensor parts is 10.13 kPa <gauge pressure>).



### WARNING

- The detector is designed to draw gases around it under the atmospheric pressure. Be sure that excessive pressure is not applied to the sampling inlet and outlet (GAS IN, GAS OUT) of the detector.
- Detected gases must be exhausted from the detected gas exhausting outlet (GAS OUT) to which an exhaust tube is connected, to a point regarded as a safe place.



### CAUTION

- The longer the tube of the GAS IN is, the longer it takes for a gas to reach the detector. Because some gases have a highly adsorptive property for the tube, resulting in a slow response and a lower reading than the actual value, the length of the GAS IN tube must be minimized.
- When the humidity in the sampling point is high, condensation may be formed inside of the tube. Make sure to avoid condensation when using a gas which is dissolved into water and corrodes contacted materials, such as a strong acid gas, because it is undetectable and furthermore may corrode internal parts. Also avoid an excessive U-shaped or V-shaped tube piping.
- Determine the inlet for the sample gas, considering the air flow of the sample gas line and the gas generating process.
- To remove dust, do not forget to attach a dust filter in the middle of the tube.
- You need to decide the length and material of the tube. Please contact RIKEN KEIKI for more information.

---

## 5

---

# How to Operate

### 5-1. Preparation for start-up

Before connecting a power supply, read and understand the following precautions. Ignoring these precautions may cause an electric shock or damage the detector.

- Check that the detector is installed properly.
- Connect the detector to a grounding circuit.
- Check that the wiring is connected to external device properly.
- Check that the power supply voltage is compliant with the specifications.
- Check that there is no clogging or leak in the connected tube. (If the connected tube is clogged, pressure is applied to the sensor, causing errors and malfunctions.)
- Check that the filter is attached properly. (The filter is specified based on the gas to be detected.)

### 5-2. Basic operating procedures

Before supplying power to the detector, check that the preparations described in "5-1. Preparation for start-up" are completed. The detector lacks a power switch. Analog output from the oxygen sensor is sent directly to the indicator/alarm unit via the cable connected without signal conversion. Assuming the cables are correctly connected, the detector will start operating as soon as the indicator/alarm unit power is turned on. Turn on the indicator/alarm unit power and check that it functions normally with reference to the operating manual of the indicator/alarm unit.

Span adjustment must be performed when a detector is first installed. Indicated oxygen concentrations may be incorrect until this adjustment has been made.



#### CAUTION

- When installing for the first time, adjust as described in "6-2. Calibration method" to ensure the indicator/alarm unit displays accurate oxygen concentrations. Adjust the indicator/alarm unit. The detector itself cannot be adjusted. For information on adjusting the indicator/alarm unit, refer to the indicator/alarm unit operating manual.

## 5-3. How to start the gas detector

Turn on the power switch of the indicator/alarm unit. Gas detection starts after the initial clear.

The following decrease may occur during the measurement of the oxygen concentration, but it is not a failure. Please recognize it in advance.

1. Indicated values fluctuate in response to changes in the air pressure

The oxygen concentration in the atmosphere fluctuates in proportion to the atmospheric pressure. Therefore, when a low air pressure such as typhoon passes, the instruction drops only slightly.

2. Oxygen sensors are affected by sudden temperature changes

If a rapid temperature change occurs in a short period of time, the indicated value may change. The sensor performs temperature compensation, but the compensation cannot follow a short-time temperature change, and the instructions may vary.

3. Effects of other gases

If the product is used in an atmosphere with a CO<sub>2</sub> concentration of 15% or more or an organic solvent, the oxygen sensor may be adversely affected and the instructions may become unstable.

4. Instruction gradually decreases when used for a long time (six month – one year)

If the sensor is used for a long period of time, the output of the sensor gradually drops, and the indication drops. In such a case, make sure that the surroundings of the detector are fresh air release, and then adjust them.

## 5-4. Flow Rate Adjustment

Set the flow rate according to the following steps.

- (1) Check that the supply side of compressed air is closed.
- (2) After making sure that the lock ring of the compact regulator adjusting knob is located at the front side (if it is at the far side, the knob will not turn), turn the adjusting knob to the LOW side (counterclockwise) until it stops. (Figure 1)
- (3) Turn the needle valve clockwise until it stops, and then turn it counterclockwise by two turns. (Figure 2)
- (4) Open the supply side of compressed air.
- (5) Turn the compact regulator adjusting knob slowly to the HIGH side (clockwise) until the float of the MC filter with flow monitor makes contact with the upper stopper and stops, and then move the lock ring to the far side to lock the adjusting knob.
- (6) Slowly turn the needle valve clockwise until the float of the MC filter with flow monitor makes contact with the upper stopper and moves up and down by one to two millimeters. (Figure 3)

The flow rate setting is now completed.

- \* If the float of the MC filter with flow monitor comes in and out of sight during operation, turn the needle counterclockwise until the float makes contact with the upper stopper and moves up and down by one to two millimeters and adjust the flow rate. If the above does not help the float to behave normally, it may indicate clogging in the gas inlet or MC filter, or other problems. In this case, perform maintenance.

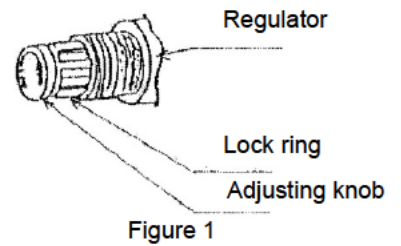

Figure 1

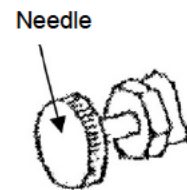

Figure 2

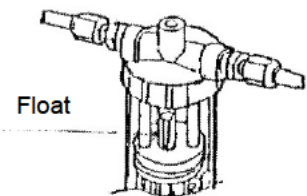

Figure 3

## 5-5. How to exit

Turn off the detector according to the followings.

- Stop supplying compressed air to the detector.
- Turn the needle valve clockwise until it stops.
- Move the adjusting knob lock ring to the front side and turn the knob to the LOW side (counterclockwise) until it stops.
- Turn off the power switch of the indicator/alarm unit.



### WARNING

- When the detector is turned off, an alarm may be triggered on the upper (central) system.
- Before turning off the detector, INHIBIT (point skip) on the upper (central) system must be activated. Decide whether the power can be turned off by checking the operation of the devices connected to the external output or external contact output terminal of the detector.

---

## 6

---

# Maintenance

The detector is an important instrument for the purpose of safety.

To maintain the performance of the detector and improve the reliability of safety, perform a regular maintenance.

Continuing to use the detector without performing maintenance will compromise the sensitivity of the gas sensor, thus resulting in inaccurate detection.

### 6-1. Maintenance intervals and items

- Daily maintenance: Perform maintenance before beginning to work.
- Monthly maintenance: Perform maintenance on the alarm circuit (alarm test) once a month.
- Regular maintenance: Perform maintenance once or more for every six months to maintain the performance as a safety unit.

Maintenance item	Maintenance content	Daily maintenance	Monthly maintenance	Regular maintenance
Power Supply Check*	Check that the power lamp lights up.	○	○	○
Status display Check*	Check that the fault lamp does not light up.	○	○	○
Flow rate check	Check the flow rate to find abnormalities.	○	○	○
Concentration Display Check*	Check that the concentration display value is zero (or 20.9 vol% on the oxygen meter). When the reading is incorrect, perform the zero adjustment (or span adjustment) after ensuring that no interference gases exist around it.	○	○	○
Filter check	Check the dust filter for dust or clogging.	○	○	○
Alarm Test*	Inspect the alarm circuit by using the alarm test function.	—	○	○
Span Adjustment*	Perform the span adjustment by using the calibration gas.	—	—	○
Gas Alarm Check*	Check the gas alarm by using the calibration gas.	—	—	○

\* Check and adjustment are performed at the indicator/alarm unit side. See the operating manual of the indicator/alarm unit for details.

#### NOTE

- Before starting alarm test or span adjustment, be sure to provide a notification to the related sections and block external signals.
-

**<About Maintenance Services>**

- We provide services on regular maintenance including span adjustment, other adjustments and maintenance.  
To make the calibration gas, dedicated tools, such as a gas cylinder of the specified concentration and gas sampling bag must be used.  
Our qualified service engineers have expertise and knowledge on the dedicated tools used for services, along with other products. To maintain the safety operation of the detector, please use our maintenance service.
- The followings are typical maintenance services. For more information, please contact RIKEN KEIKI.

**Main Services**

Power Supply Check	: Checks the power supply voltage. Verifies that the power lamp lights up. (Verifies that relevant points can be identified on the system.) (When a UPS (uninterruptible power system) is used, checks the operation with the UPS.)
Concentration Display Check	: Verifies that the concentration display value is zero (or 20.9 vol% on the oxygen deficiency meter) by using the zero gas. Performs the zero adjustment (fresh air adjustment) if the reading is incorrect.
Flow Rate Check	: Checks the flow rate indicator to find abnormalities. Checks the flow rate by using an external flow meter to verify the correctness of the flow rate indicator on the gas detector. If the flow rate is incorrect, performs the flow rate adjustment.
Filter Check	: Checks the dust filter for dust or clogging. Replaces a dirty or clogged dust filter.
Alarm Test	: Inspects the alarm circuit by using the alarm test function. <ul style="list-style-type: none"> <li>• Checks the alarm lamps. (Checks ALM1 activation.)</li> <li>• Checks the external alarm. (Checks the activation of the external alarm, such as a buzzer.)</li> </ul>
Span Adjustment	: Performs the span adjustment by using the calibration gas.
Gas Alarm Check	: Checks the gas alarm by using the calibration gas. <ul style="list-style-type: none"> <li>• Checks the alarm. (Checks triggering of alarm when the alarm setpoint is reached.)</li> <li>• Checks the delay time. (Checks time to delay until the alarm is triggered.)</li> <li>• Checks the alarm lamps. (Checks ALM1 activation.)</li> <li>• Checks the external alarm. (Checks the activation of external alarms, such as a buzzer and reset signal.)</li> </ul>
Cleaning and Repair of Device (Visual Diagnosis)	: Checks dust or damage on surface, cover or internal parts of the detector, cleans and repairs such parts of the detector. Replaces parts which are cracked or damaged.
Device Operation Check	: Uses the keys to check the operation of functions and parameters.
Replacement of Consumable Parts	: Replaces consumable parts, such as a sensor, filter and pump.



## 6-2. Calibration method

Perform a calibration with the indicator/alarm unit (zero adjustment/span adjustment mode) using the calibration gas.

- Zero adjustment gas (more than N2 99.9% collected in a gas sampling bag)
- Calibration gas (collected in a gas sampling bag)
- Gas sampling bag for exhaust gas

<Device Connection Example>

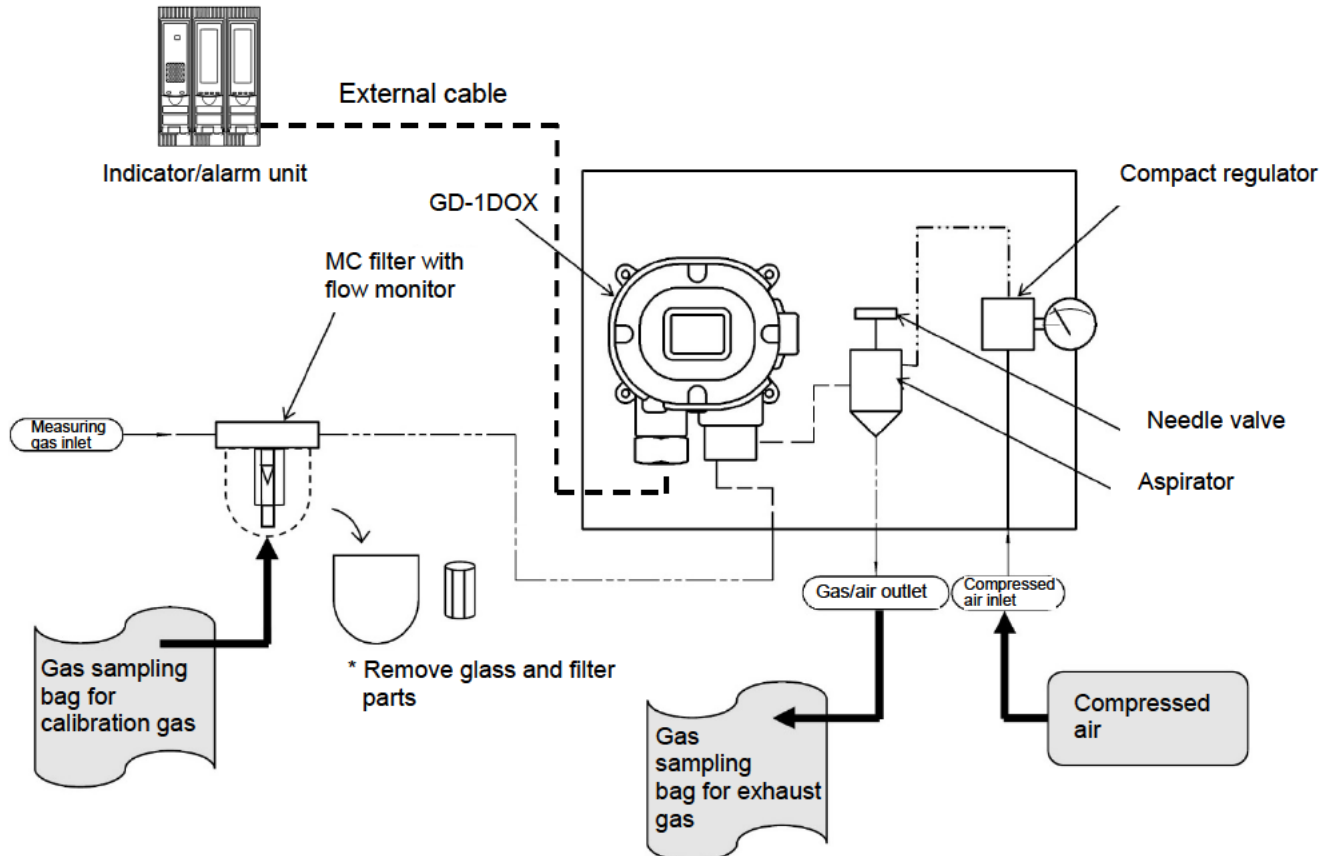

### NOTE

Check and adjustment are performed at the indicator/alarm unit side. See the operating manual of the indicator/alarm unit for details.

### <Span Adjustment (AIR adjustment)>

Adjust the reading to "20.9" at the indicator/alarm unit side under the condition that no gas is present around the detection point.

If a gas is present around the detection point, collect fresh air in a gas sampling bag or the like and release it at the detection point for a certain time or so before starting the AIR adjustment.

- ① Fill the gas sampling bag with calibration gas (fresh air for the oxygen deficiency alarm or gas with a concentration in the region of the alarm setpoint for all other cases).  
However, for simplified calibration, you can use ambient air as 20.9 vol% calibration gas after confirming that the ambient air pressure is 1 atmosphere (1,000 hPa  $\pm$ 50 hPa) and that concentrations of impurities are negligibly low relative to the calibration gas concentration.
- ② After the gas is introduced and the oxygen concentration reading in the indicator/alarm section is stabilized, the indicator/alarm section will be adjusted so that this indication reading indicates the calibration gas concentration reading.
- ③ Stop the calibration gas flow and verify that the oxygen concentration reading is 20.9 vol%. (Span adjustment complete)



#### **WARNING**

When the span adjustment (AIR adjustment) is performed in the atmosphere, check the atmosphere for freshness before beginning the adjustment. If interference gases exist, the adjustment cannot be performed properly, thus leading to dangers when the gas leaks.



#### **CAUTION**

- Before starting the span adjustment (AIR adjustment), provide the detector with the calibration gas and wait until the reading is stabilized.

## <Zero Adjustment (N<sub>2</sub> adjustment)>

This is used to perform the zero adjustment.

When the detector is used to prevent oxygen deficiency, zero adjustment is not required.

- ① Fill the gas sampling bag with zero gas (at least 99.9 vol% nitrogen gas).
- ② After the gas is introduced and the oxygen concentration reading has stabilized on the indicator/alarm unit, adjust the indicator/alarm unit so that the reading displays zero.
- ③ Stop the zero gas flow and verify that the oxygen concentration reading returns to 20.9 vol%. (Zero adjustment complete)



### CAUTION

Before starting the zero adjustment(N<sub>2</sub> adjustment), provide the detector with the zero adjustment (more than N<sub>2</sub> 99.9vol%) gas and wait until the indicator is stabilized.

### NOTE

The span adjustment requires dedicated tools. We recommend the adjustment be performed by RIKEN KEIKI.

#### Criteria

Alarm delay time (time to alarm at 18% alarm point) ..... within 5min

Indicate accuracy .....  $\pm 0.7\text{vol\%}$  of gas concentration value

If the criteria are not met

After performing Air adjustment, check the zero point by flowing N<sub>2</sub> 99.9vol%. If the guideline is not zero, perform zero adjustment (on the instruction alarm unit side) while flowing N<sub>2</sub> gas.

After zero adjustment, perform Air adjustment again, and perform the above-described gas calibration.

If calibration cannot be performed again, the sensor may be defective. Replace the sensor.

## 6-3. Replacement parts

### <Sensor Replacement>

#### NOTE

• The gas calibration using the standard gas is required after the sensor is replaced. Please request it to our overseas sales department or local representatives.

### <Replacement of Regular Replacement Parts>

#### List of recommended regular replacement parts

No.	Name	Maintenance intervals	Replacement intervals	Quantity (pieces/unit)	Remarks
1	Guard assembly	6 months	3 - 8 years	1	
2	Aspirator cap	6 months	3 - 8 years	1	

\* The operation must be checked after replacement by a qualified service engineer. For the stable operation of the unit and safety, ask a qualified service engineer to take care of replacement of the parts that operation must be checked. Request RIKEN KEIKI for operation check.

#### NOTE

- The above replacement intervals are recommendation only. The intervals may change depending on the operating conditions. These intervals do not mean the warranty periods either. The result of the regular maintenance may determine when to replace the parts.

---

# 7

---

## Storage, Relocation and Disposal

### 7-1. Procedures to store the gas detector or leave it for a long time

The gas detector must be stored under the following environmental conditions.

- In a dark place under the normal temperature and humidity away from direct sunlight
- In a place where gases, solvents or vapors are not present

### 7-2. Procedures to relocate the detector or use it again

When the detector is relocated, select a new place in accordance with "4-2. Precautions for installation sites" and "4-4. How to install".

For information on wiring, see "4-6. How to wire". The unpowered time must be minimized when the detector is relocated.



#### CAUTION

- When using a relocated or stopped/stored detector again, never fail to perform a calibration. For information on readjustment including a calibration, please contact RIKEN KEIKI.

### 7-3. Disposal of products

When the detector is disposed of, it must be treated properly as an industrial waste in accordance with the local regulations.

## 8

# Troubleshooting

The Troubleshooting does not explain the causes of all the malfunctions which occur on the detector. This simply helps to find the causes of malfunctions which frequently occur. If the detector shows a symptom which is not explained in this manual, or still has malfunctions even though remedial actions are taken, please contact our overseas sales department or local representatives. Be sure to read the operating manual of the indicator/alarm unit as well.

## <Abnormalities on Unit>

\* Take remedial actions to indicator/alarm unit as well See the operating manual of the indicator/alarm unit for details.

Symptom/Display	FAULT	Causes	Actions
<u>Sensor error appears on the indicator side</u>	—	The wiring is not correct.	Connect the wiring properly.
		The terminal plate is removed.	Connect the terminal plate properly.
		Cable abnormalities (open circuit/not connected/short circuit)	Check the wiring of detector and related devices around it.
		The sensor is not connected.	Check the sensor is installed properly.
		Faults of the sensor	Replace the sensor with a new one.
<u>Abnormal operations</u>	—	Disturbances by sudden surge noise, etc.	Turn off and restart the indicator/alarm unit. If such a symptom is observed frequently, take appropriate measures to eliminate the noise.

## 9

# Product Specifications

## 9-1. List of specifications

Model	GD-1DOX-AS
Detection principle	Galvanic cell method
Detection gas	O <sub>2</sub>
Applicable gas detector head	GD-1DOX
Detection method	Aspirator suction type
Sampling condition	Equivalent to atmospheric pressure (compressed air: 0.1 - 0.7 MPa, maximum use amount: 3 L/min <converted into atmospheric pressure>)
Suction flow	1.5±0.5L/min
Transmission cable	CVVS worth of shield cable(1.25mm <sup>2</sup> or 2.0mm <sup>2</sup> ) · 2-core
Cabling port <sup>*1</sup>	Pressure proof packing gland<G3/4>(Compatible cables φ9.6~φ13.0mm in outer diameter)
Piping port <sup>*2</sup>	Gas IN: Rc1/4 (O.D ø6-1t, half-union for PTFE tube <PP> supplied) OUT: O.D ø8-1t, flare union for Cu tube <Bs> Compressed air IN: O.D ø8-1t, flare union for Cu tube <Bs>
Operating temperature range	-10~+40°C(non-rapidly-vary)
Operating humidity range	Below 95%RH(non-condensing/non-rapidly-vary)
Structure	Wall mounting sampling unit
Explosion-proof structure	Flame proof structure
Explosion-proof class	Ex d II C T6 X(TIIS,Japan)
Dimensions	Approx.400(W)×265(H)×102(D)mm(projection portions excluded)
Weight	Approx.6.3kg
Color	Detection body: Munsell 7.5BG5/2

\*1 Please specify your request when ordering.

\*2 When a half-union for gas IN side is changed, check also the external filter (IN/OUT diameter) carefully.

## 9-2. Detection principle

[Detection principle]

A negative electrode of noble metal and a positive electrode of lead are placed in a resin container filled with electrolyte. A part of the container is opened and covered with a barrier. The negative electrode is installed in contact with the barrier. Lead wires are drawn from the positive and negative electrodes to obtain outputs. A thermistor is connected between the lead wires to perform temperature compensation for the sensor outputs.

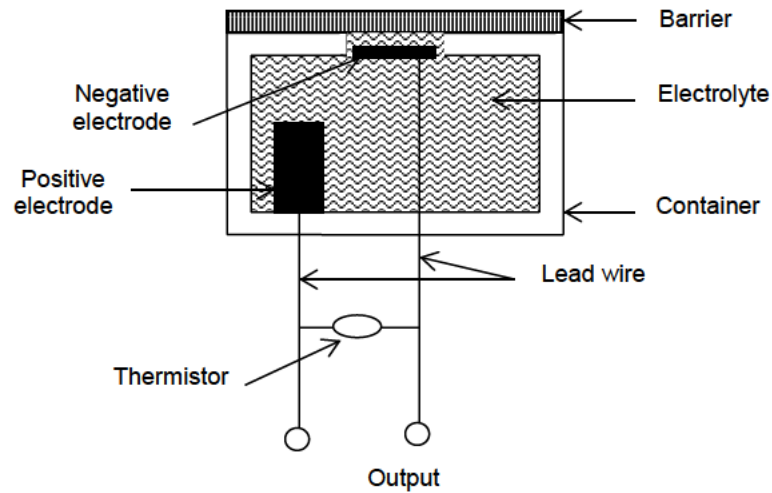



---

# 10

---

## Definition of Terms

Galvanic cell type	This is a principle of the sensor installed in the detector head. See "9-2. Detection principle" for details.
vol%	A unit used to express the percentage of a specific substance (or gas) in a volume of solution.
Atmosphere	An atmosphere with a temperature within the range of -10 to 40°C and a humidity of 95% RH or less at one atmospheric pressure (1013 hPa).
Full scale	Maximum value of the detection range.
Calibration	Adjusts the readings to the calibration gas concentration value by using the calibration gas.

Manual Log

Rev.	Amendment	Issue data
0	First issue (PT2-2880)	1/31/2022